



Accessories / Accessori

Tracks, lower guides and wall brackets
Binari, guide inferiori e squadrette



Tracks / Binari

| Tracks / Binari | | ALUMINUM FINISHES CODES / CODICI FINITURE ALLUMINIO | |  |
|-----------------|---|---|--|---|
| CODE / CODICE | | FINISH COLOR / COLORE FINITURA | | |
| 8 00 0.0 |  | 00 G | Raw / Mill Finish / Neutro / Grezzo | STANDARD |
| 8 01 0.0 |  | 01 A | Anodized Silver / Argento | |
| 8 02 0.0 |  | 02 AS | Brushed Anodized Silver / Argento Spazzolato | |

| Tracks / Binari | | PLASTIC FINISHES CODES / CODICI FINITURE PLASTICA | |  |
|-----------------|---|---|---------------|---|
| CODE / CODICE | | FINISH COLOR / COLORE FINITURA | | |
| 8 23 0.0 |  | 23 GR | Gray / Grigio | STANDARD |

**ALUMINIUM TRACKS ONLY SUITABLE FOR STANDARD STOPPER APPLICABLE TO WALL AND CEILING
BINARI IN ALLUMINIO ADATTI SOLO PER FERMI A PINZA APPLICABILI A PARETE E SOFFITTO**

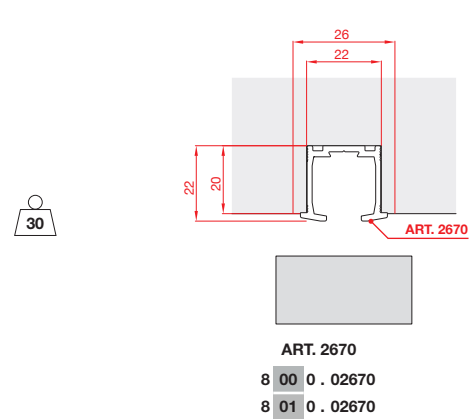
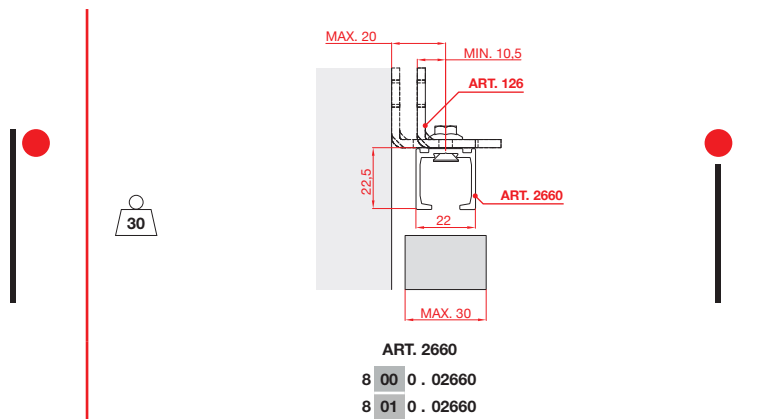

**ALUMINIUM TRACKS SUITABLE FOR GRIP CLIPS AND SOFT CLOSING APPLICABLE TO WALL
BINARI IN ALLUMINIO ADATTI PER FERMI A PINZA E FERMI AMMORTIZZATI APPLICABILI A PARETE**

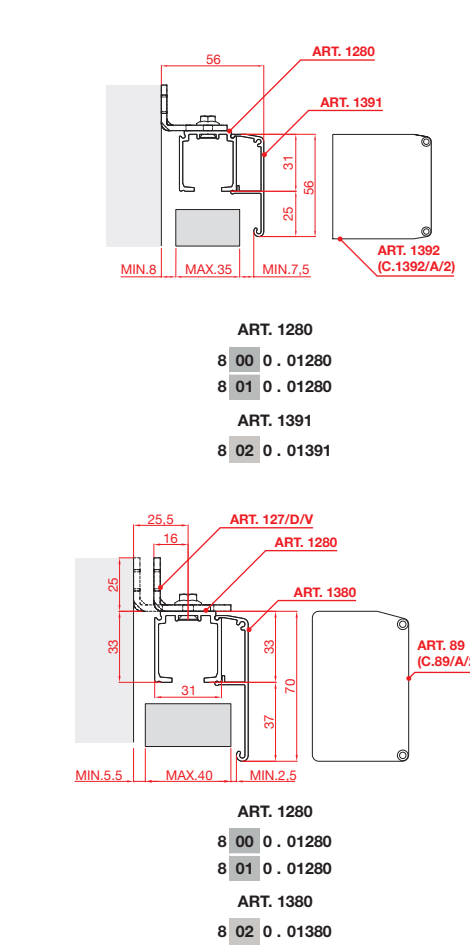
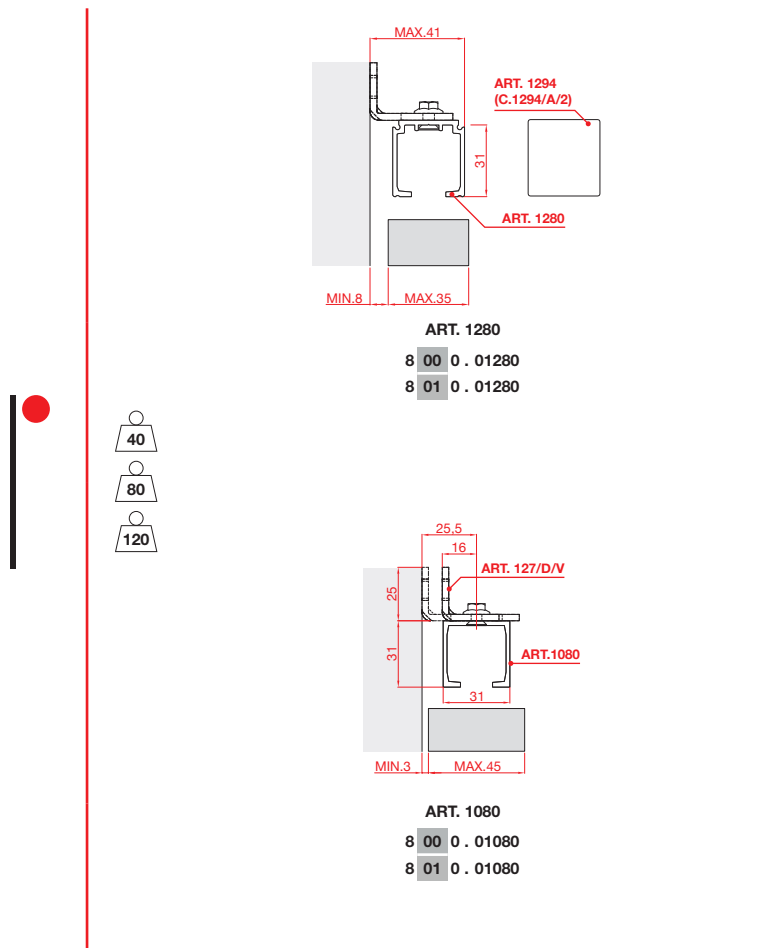

ALUMINIUM TRACKS SUITABLE FOR GRIP CLIPS AND SOFT CLOSING APPLICABLE TO CEILING
BINARI IN ALLUMINIO ADATTI PER FERMI A PINZA E FERMI AMMORTIZZATI APPLICABILI A SOFFITTO

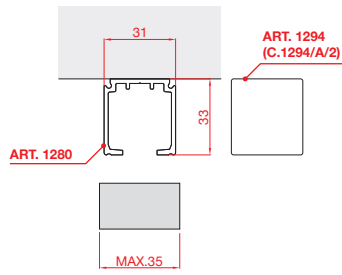

ART. 1280
 8 00 0 . 01280
 8 01 0 . 01280

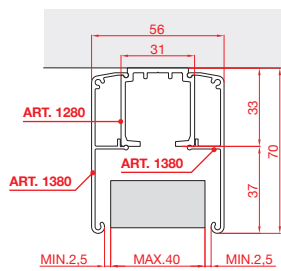

ART. 1280
 8 00 0 . 01280
 8 01 0 . 01280
ART. 1380
 8 02 0 . 01380

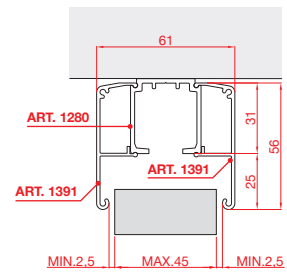

ART. 1280
 8 00 0 . 01280
 8 01 0 . 01280
ART. 1391
 8 02 0 . 01391

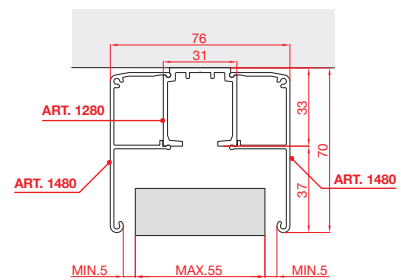

ART. 1280
 8 00 0 . 01280
 8 01 0 . 01280
ART. 1480
 8 02 0 . 01480



ALUMINIUM TRACKS SUITABLE FOR STANDARD STOPPERS AND SOFT CLOSING APPLICABLE TO WALL
BINARI IN ALLUMINIO ADATTI PER FERMI A PINZA E FERMI AMMORTIZZATI APPLICABILI A PARETE

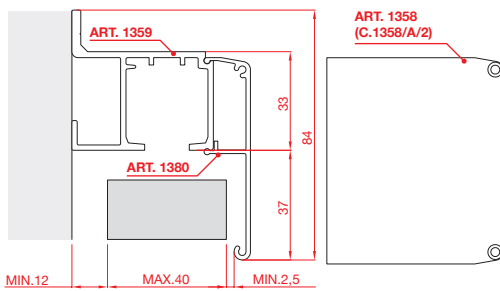

ART. 1359
 8 00 0 . 01359
 8 01 0 . 01359
ART. 1380
 8 02 0 . 01380

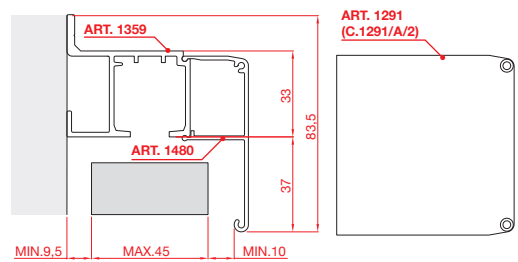

ART. 1359
 8 00 0 . 01359
 8 01 0 . 01359
ART. 1480
 8 02 0 . 01480



Tracks / Binari

ALUMINIUM TRACKS SUITABLE FOR STANDARD STOPPERS AND SOFT CLOSING APPLICABLE TO WALL
 BINARI IN ALLUMINIO ADATTI PER FERMI A PINZA E FERMI AMMORTIZZATI APPLICABILI A PARETE

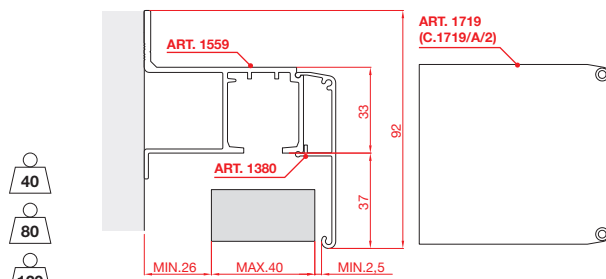

ART. 1559
 8 00 0 . 01559
 8 01 0 . 01559
ART. 1380
 8 02 0 . 01380

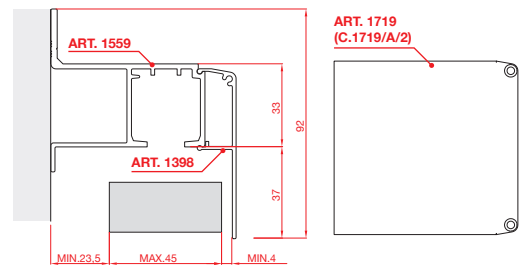

ART. 1559
 8 00 0 . 01559
 8 01 0 . 01559
ART. 1398
 8 02 0 . 01398

ALUMINIUM TRACKS SUITABLE FOR STANDARD STOPPERS AND SOFT CLOSING APPLICABLE TO WALL
 BINARI IN ALLUMINIO ADATTI PER FERMI A PINZA E FERMI AMMORTIZZATI APPLICABILI A PARETE

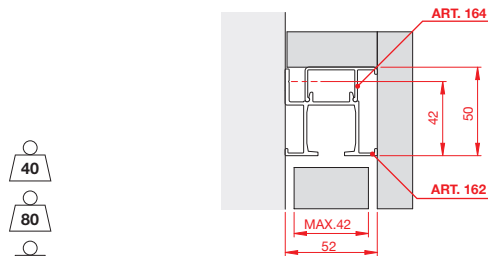

ART. 162
 8 00 0 . 00162
 8 01 0 . 00162
ART. 164
 8 01 0 . 00164

FOR WOODEN VALANCES
 PER MANTOVANE CLASSICHE IN LEGNO

ALUMINIUM TRACKS SUITABLE FOR STANDARD STOPPERS AND SOFT CLOSING APPLICABLE TO WALL
 BINARI IN ALLUMINIO ADATTI PER FERMI A PINZA E FERMI AMMORTIZZATI APPLICABILI A PARETE

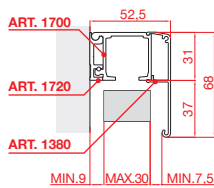

ART. 1700
 8 00 0 . 01700
 8 01 0 . 01700
ART. 1720
 8 00 0 . 01720
 8 01 0 . 01720
ART. 1380
 8 02 0 . 01380

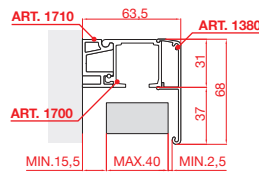

ART. 1700
 8 00 0 . 01700
 8 01 0 . 01700
ART. 1710
 8 00 0 . 01710
 8 01 0 . 01710
ART. 1380
 8 02 0 . 01380

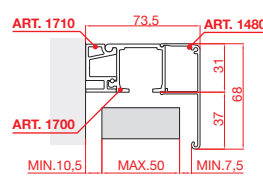

ART. 1700
 8 00 0 . 01700
 8 01 0 . 01700
ART. 1710
 8 00 0 . 01710
 8 01 0 . 01710
ART. 1480
 8 02 0 . 01480

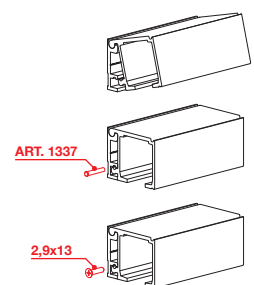

**ALUMINIUM TRACKS SUITABLE FOR STANDARD STOPPERS AND SOFT CLOSING APPLICABLE TO WALL
BINARI IN ALLUMINIO ADATTI PER FERMI A PINZA E FERMI AMMORTIZZATI APPLICABILI A PARETE**

ART. 1700
8 00 0 . 01700
8 01 0 . 01700

ART. 1720
8 00 0 . 01720
8 01 0 . 01720

ART. 1391
8 02 0 . 01391

ART. 1700
8 00 0 . 01700
8 01 0 . 01700

ART. 1710
8 00 0 . 01710
8 01 0 . 01710

ART. 1391
8 02 0 . 01391

**ALUMINIUM TRACKS FOR 2 DOORS, FOR CLASSIC STOPPERS AND SOFT CLOSING APPLICABLE TO WALL
BINARI IN ALLUMINIO PER 2 PORTE, PER FERMI A PINZA E FERMI AMMORTIZZATI, FISSAGGIO A PARETE**

ART. 1296
8 00 0 . 01296
8 01 0 . 01296

ART. 1297
8 02 0 . 01297

**ALUMINIUM TRACKS SUITABLE FOR CLASSIC STOPPERS AND SOFT CLOSING APPLICABLE TO WALL
BINARI IN ALLUMINIO ADATTI PER FERMI A PINZA E FERMI AMMORTIZZATI APPLICABILI A PARETE**

ART. 1080
8 00 0 . 01080
8 01 0 . 01080

ART. 1636
8 00 0 . 01636
8 01 0 . 01636

ART. 1638
8 02 0 . 01638

Tracks / Binari

ALUMINIUM TRACKS SUITABLE FOR GRIP CLIPS AND SOFT CLOSING APPLICABLE TO CEILING
 BINARI IN ALLUMINIO ADATTI PER FERMI A PINZA E FERMI AMMORTIZZATI APPLICABILI A SOFFITTO

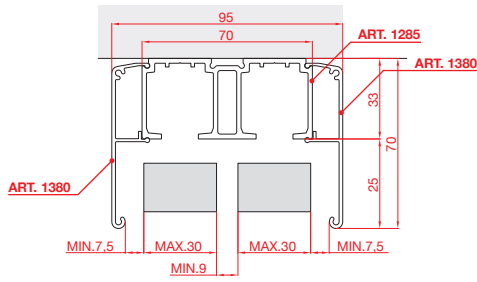

ART. 1285
 8 00 0 . 01285
 8 01 0 . 01285
ART. 1380
 8 02 0 . 01380

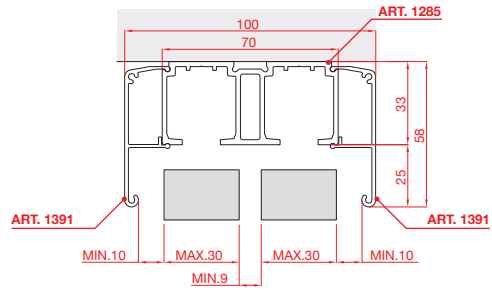

ART. 1285
 8 00 0 . 01285
 8 01 0 . 01285
ART. 1391
 8 02 0 . 01391

ALUMINIUM TRACKS SUITABLE FOR GRIP CLIPS AND SOFT CLOSING APPLICABLE TO CEILING
 BINARI IN ALLUMINIO ADATTI PER FERMI A PINZA E FERMI AMMORTIZZATI APPLICABILI A SOFFITTO

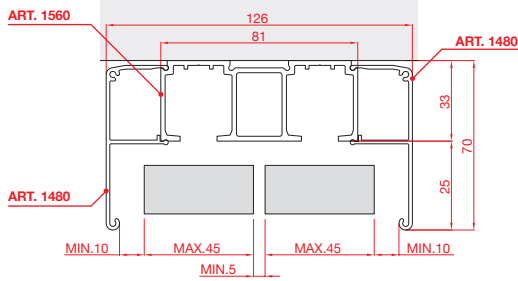

ART. 1560
 8 00 0 . 01560
 8 01 0 . 01560
ART. 1480
 8 02 0 . 01480

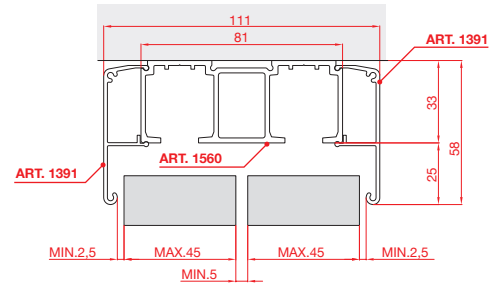

ART. 1560
 8 00 0 . 01560
 8 01 0 . 01560
ART. 1391
 8 02 0 . 01391

ALUMINIUM TRACKS FOR 3 DOORS, FOR CLASSIC STOPPERS AND SOFT CLOSING APPLICABLE TO CEILING
 BINARI IN ALLUMINIO PER 3 PORTE, PER FERMI A PINZA E FERMI AMMORTIZZATI APPLICABILI A SOFFITTO

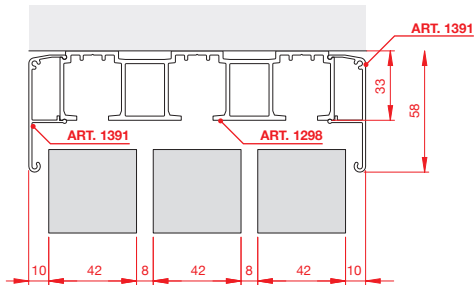

ART. 1298
 8 00 0 . 01298
 8 01 0 . 01298
ART. 1391
 8 02 0 . 01391

CAP COVERS COPERTURE TAPPI

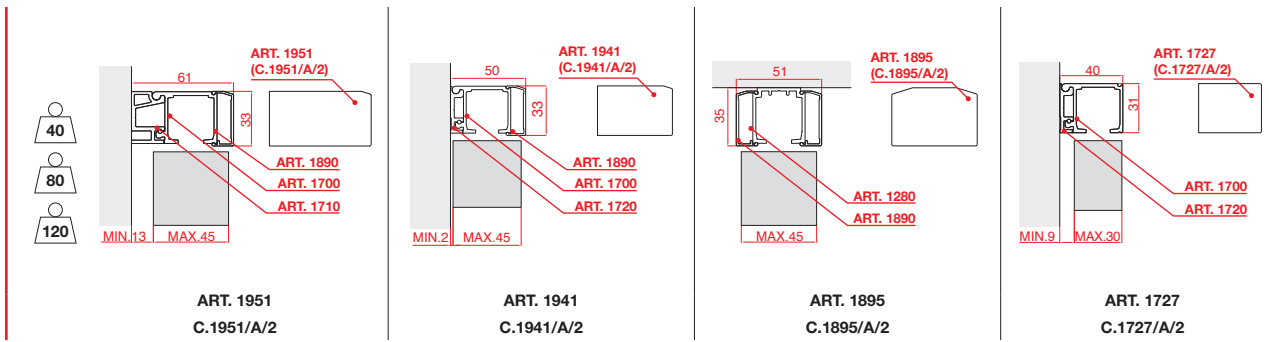

ALUMINIUM TRACKS ONLY SUITABLE FOR CLASSIC STOPPERS APPLICABLE TO WALL BINARI IN ALLUMINIO ADATTI SOLO PER FERMI A PINZA APPLICABILI A PARETE

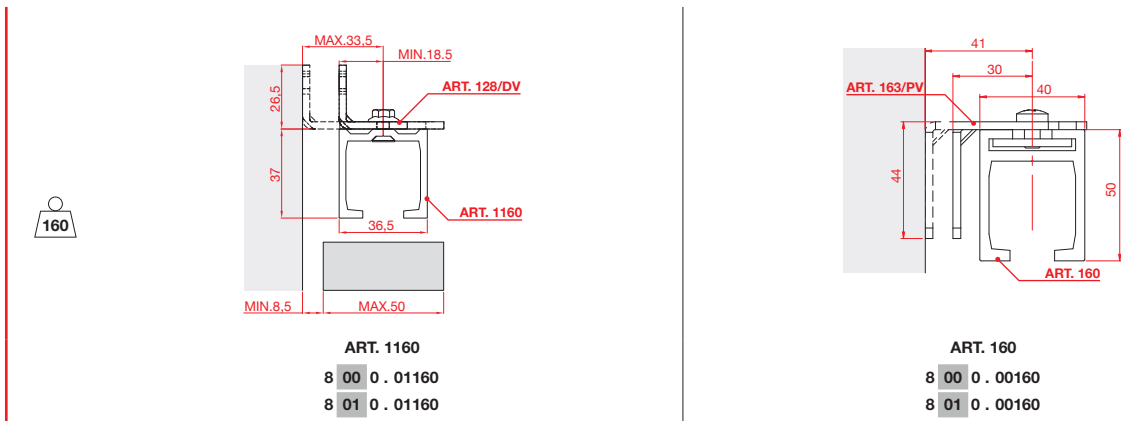

ALUMINIUM TRACKS ONLY SUITABLE FOR CLASSIC STOPPERS APPLICABLE TO WALL BINARI IN ALLUMINIO ADATTI SOLO PER FERMI A PINZA APPLICABILI A PARETE

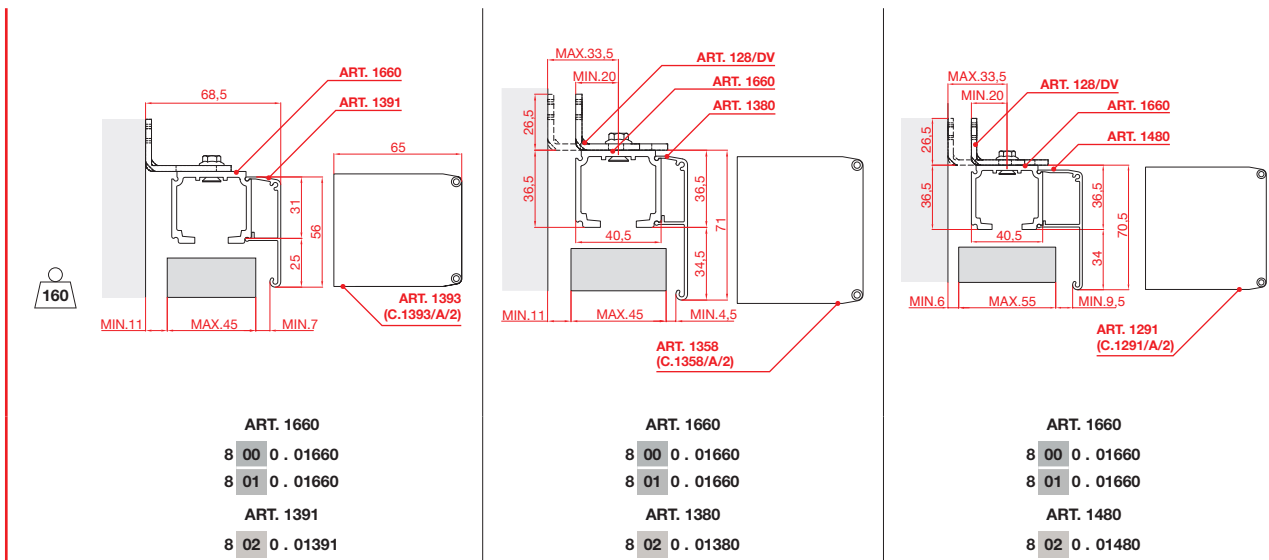

Tracks / Binari

ALUMINIUM TRACKS SUITABLE FOR GRIP CLIPS AND SOFT CLOSING APPLICABLE TO CEILING
 BINARI IN ALLUMINIO ADATTI PER FERMI A PINZA E FERMI AMMORTIZZATI APPLICABILI A SOFFITTO

ART. 1660
 8 00 0 . 01660
 8 01 0 . 01660
 ART. 1391
 8 02 0 . 01391

ART. 1660
 8 00 0 . 01660
 8 01 0 . 01660
 ART. 1380
 8 02 0 . 01380

ART. 1660
 8 00 0 . 01660
 8 01 0 . 01660
 ART. 1480
 8 02 0 . 01480

ALUMINIUM TRACKS ONLY SUITABLE FOR CLASSIC STOPPERS APPLICABLE TO WALL AND CEILING
 BINARI IN ALLUMINIO ADATTI SOLO PER FERMI A PINZA APPLICABILI A PARETE E SOFFITTO

ART. 201
 8 00 0 . 00201
 8 01 0 . 00201

ART. 234
 8 00 0 . 00234
 8 01 0 . 00234

ART. 234
 8 00 0 . 00234
 8 01 0 . 00234

ALUMINIUM TRACKS ONLY SUITABLE FOR CLASSIC STOPPERS APPLICABLE TO WALL AND CEILING
 BINARI IN ALLUMINIO ADATTI SOLO PER FERMI A PINZA APPLICABILI A PARETE E SOFFITTO

ART. 3480
 8 00 0 . 03480
 8 01 0 . 03480
 ART. 3490
 8 02 0 . 03490

ART. 3480
 8 00 0 . 03480
 8 01 0 . 03480
 ART. 3490
 8 02 0 . 03490

Lower guides / Guide inferiori

LOWER GUIDES / GUIDE INFERIORI



30

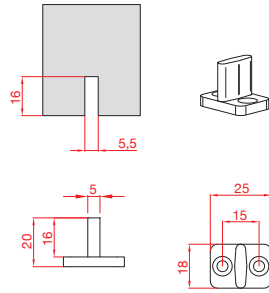

ART. 1032

40
80

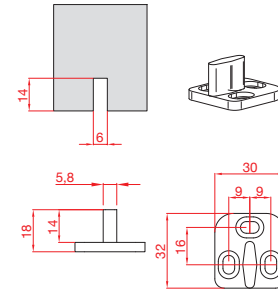

ART. 45

LOWER GUIDES / GUIDE INFERIORI



120

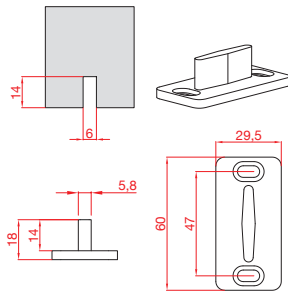

ART. 93

30
40
80

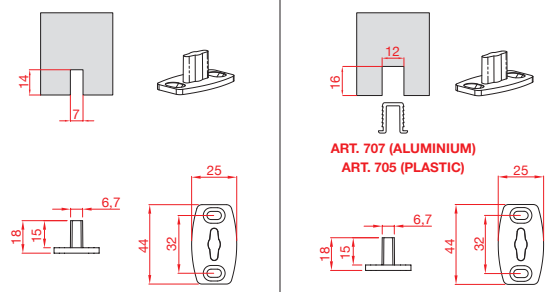

ART. 57

ART. 707 (ALUMINIUM)
ART. 705 (PLASTIC)

LOWER GUIDES / GUIDE INFERIORI



30
40
80
120

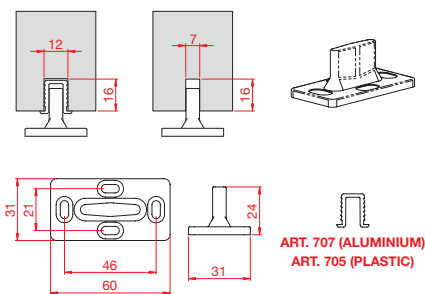

ART. 65

ART. 707 (ALUMINIUM)
ART. 705 (PLASTIC)

160
240

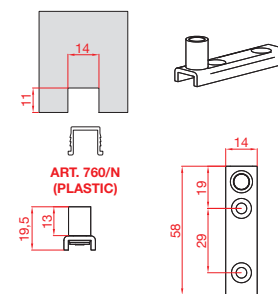

ART. 124

ART. 760/N
(PLASTIC)

Lower guides / Guide inferiori

LOWER GUIDES / GUIDE INFERIORI

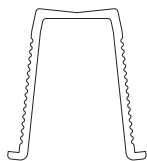
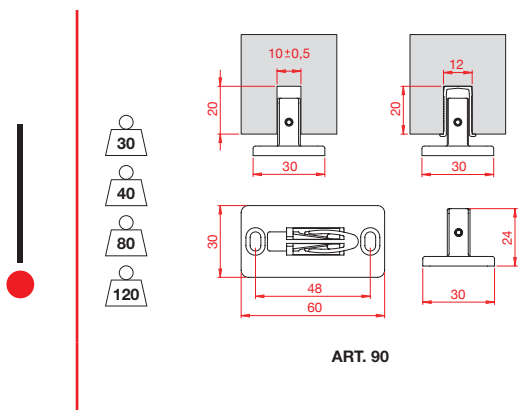

ART. 121
8 23 0. 00121

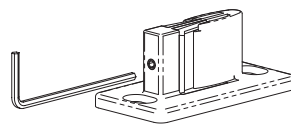

REGULATION / REGOLAZIONE

PATENTED

LOWER GUIDES / GUIDE INFERIORI

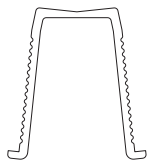
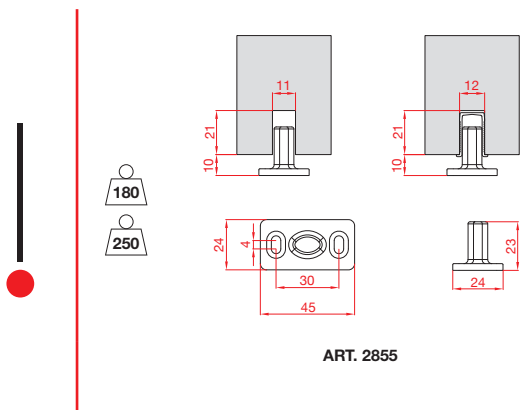

ART. 121
8 23 0. 00121

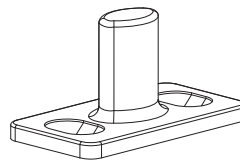

NEW

Wall bracket / Squadrette

BRACKETS FOR ALUMINUM TRACKS / SQUADRETTE PER BINARI IN ALLUMINIO

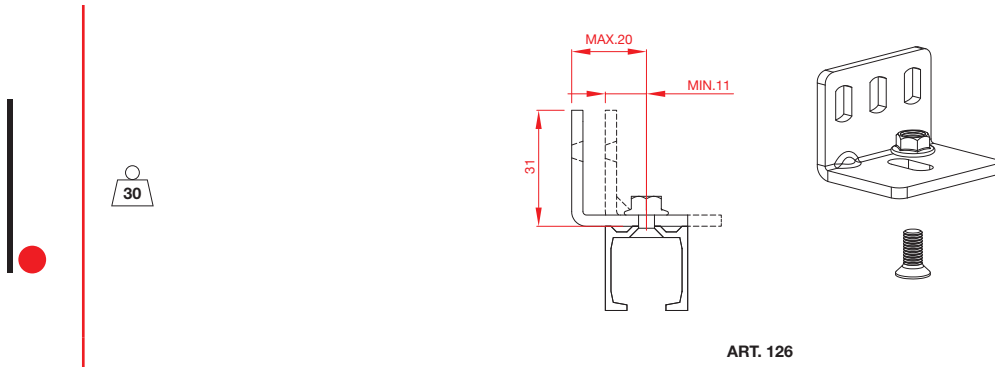

ART. 126

BRACKETS FOR ALUMINUM TRACKS / SQUADRETTE PER BINARI IN ALLUMINIO

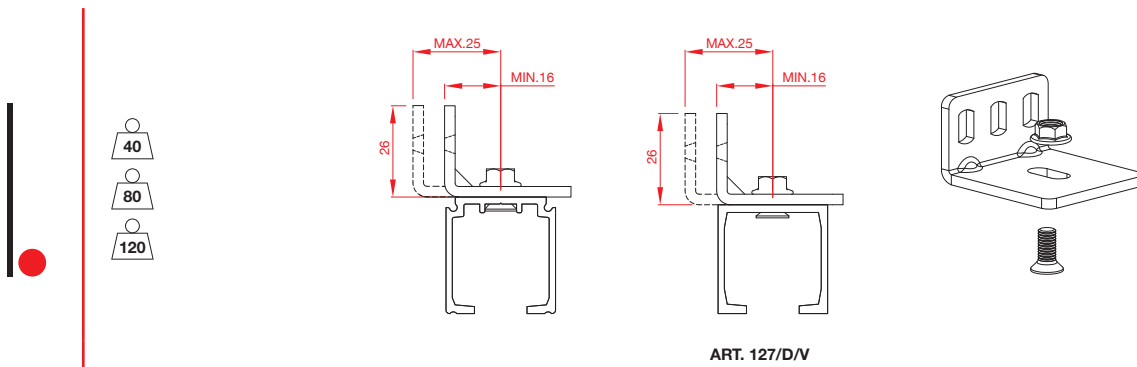

ART. 127/D/V

BRACKETS FOR ALUMINUM TRACKS / SQUADRETTE PER BINARI IN ALLUMINIO

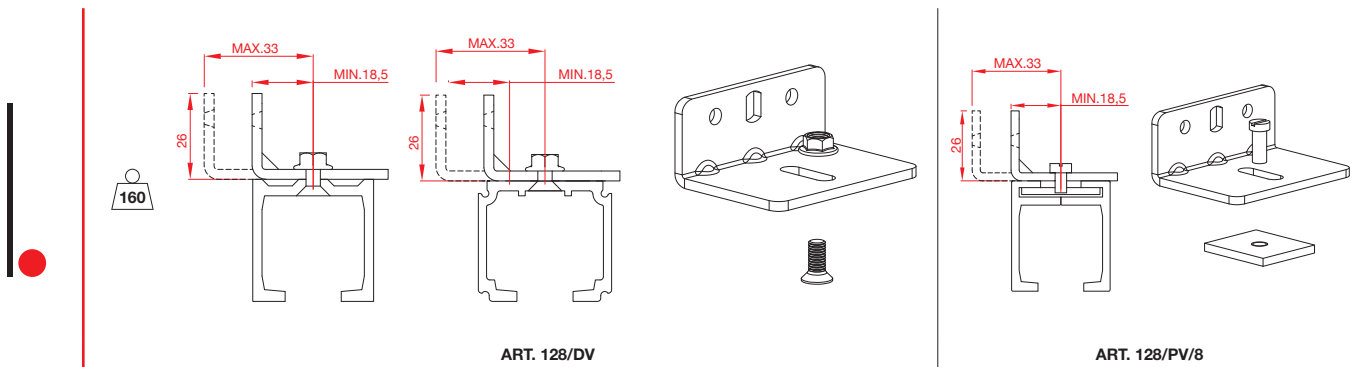

ART. 128/DV

ART. 128/PV/8

BRACKETS FOR ALUMINUM TRACKS SQUADRETTE PER BINARI IN ALLUMINIO

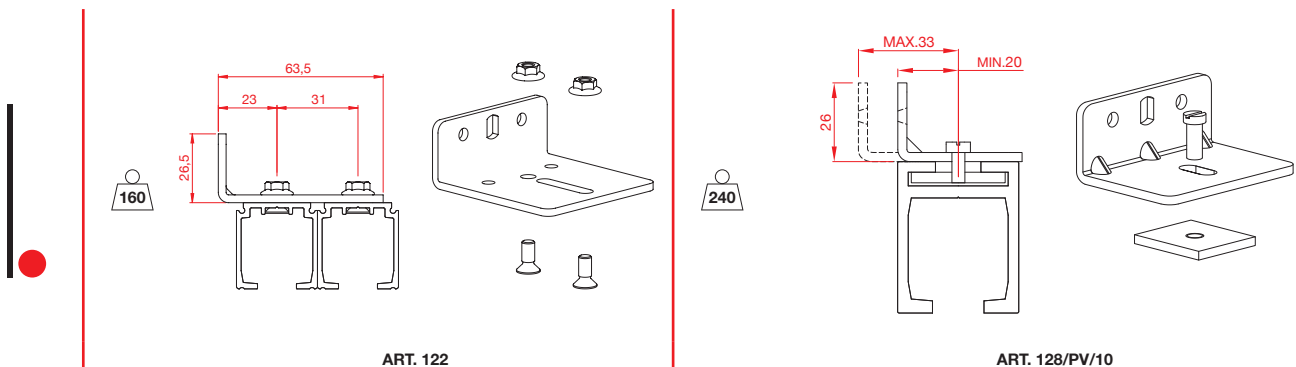

ART. 122

ART. 128/PV/10

Wall bracket / Squadrette

BRACKETS FOR ALUMINUM TRACKS / SQUADRETTE PER BINARI IN ALLUMINIO

NEW

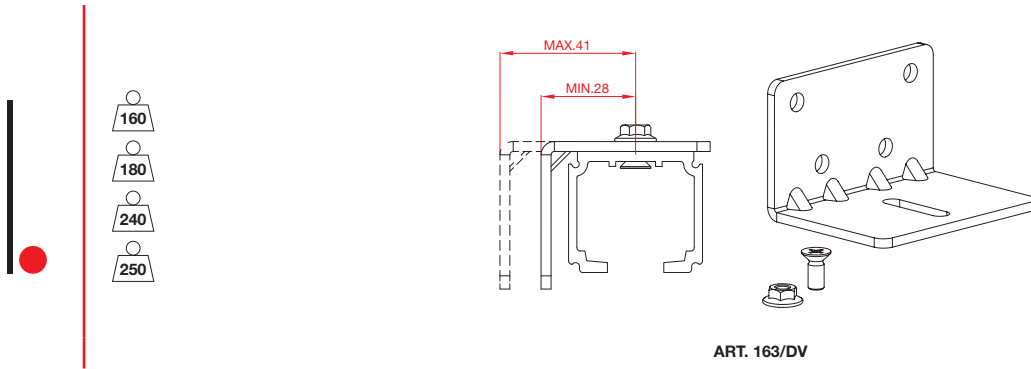

BRACKETS FOR ALUMINUM TRACKS / SQUADRETTE PER BINARI IN ALLUMINIO

NEW

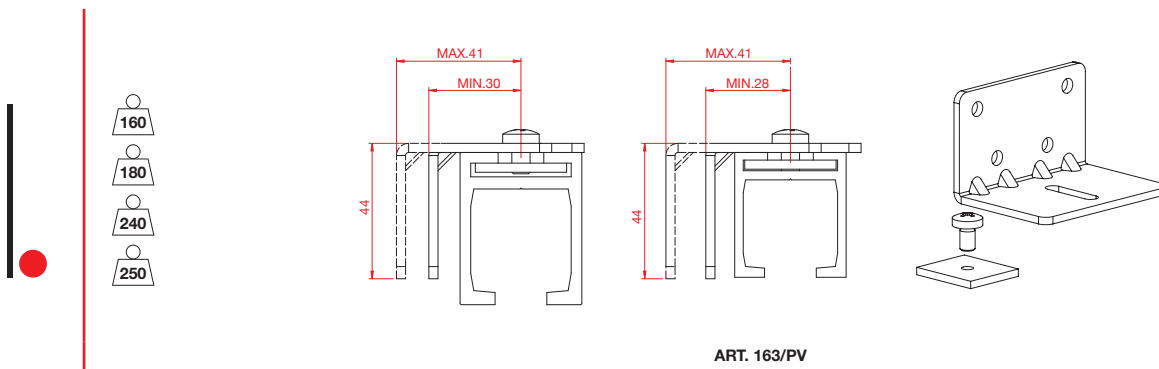



Accordion

Accordion door
Porta pieghevole a fisarmonica

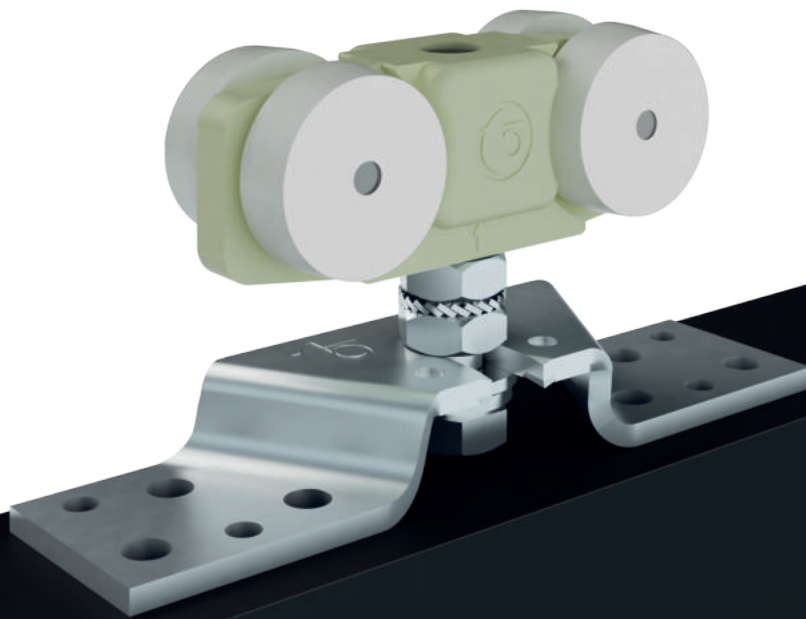



SPECIALS
of the
MONTH

| | |
|--|---|
| Mothers Day Feast * P124 MEALS IN HONOR OF Mom | FOOD LOVER'S TOUR of Charleston P136 |
| 30 MIN. MEALS * P108 | OUTDOOR Baseball PARTY * P118 |
| SAMMIES PASTA-BREAKFAST * P130 | AMERICAS LUNCHESES PARTY |

Accordion system is dedicated to **multiple leaves folding doors**, combinable with pivot joints or hinges.

The system allows a configuration of **three or four leaves**.

The **sliding system is fixed in centrally to each leaf**, in order to grant an always balanced motion.







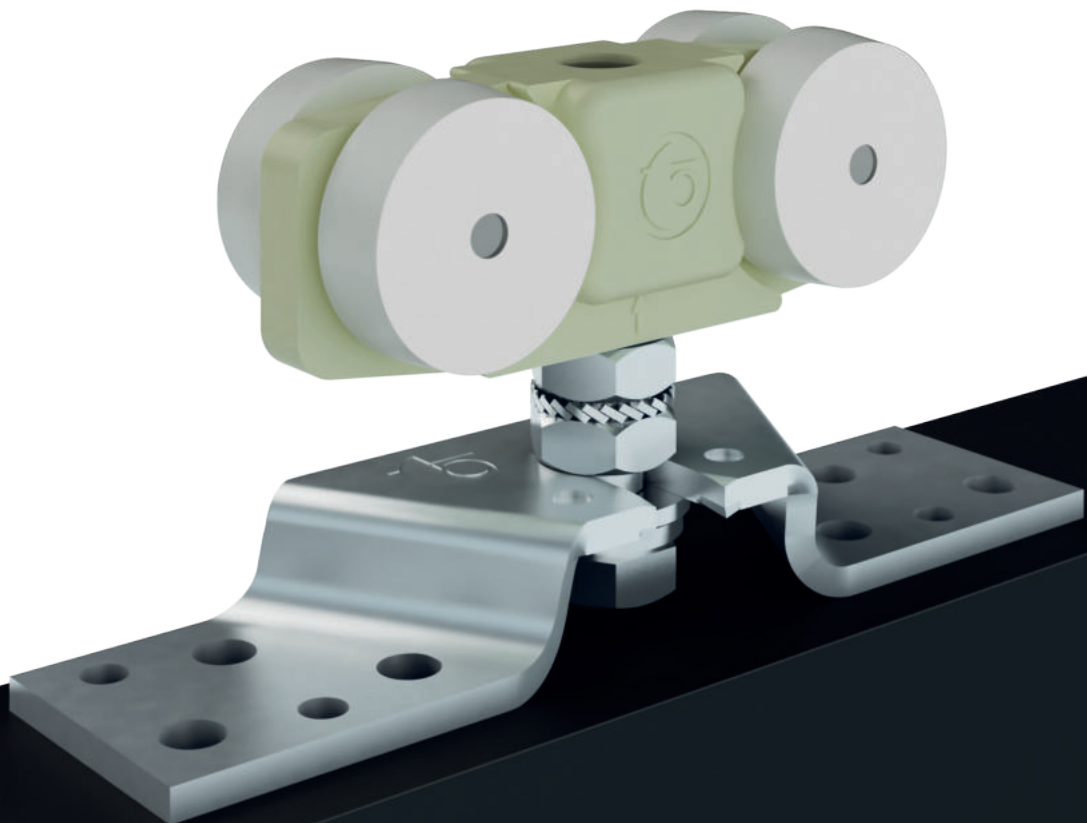

Accordion è il sistema per **porte a fisarmonica pieghevoli** ad ante multiple, utilizzabile con cardini o cerniere.

Il sistema permette una **configurazione a tre o a quattro porte**.

Lo **scorrevole** viene **fissato centralmente**, per il corretto bilanciamento delle ante.



Accordion COMPLETE BOX KIT / KIT COMPLETO IN SCATOLA 

| | | | |
|----------|-----------------------------|---|---|
| K | Complete kit / Kit completo | | |
| | | | |
| | 0223 |  | N° 4 Doors N° 4 Porte |
| | 0224 |  | N° 3 Doors N° 3 Porte |
| | | | |
| | | 1 |  With hinges - ART. 1138 Con cardini - ART. 1138 |
| | | 2 |  With hinges - ART. 1148 Con cardini - ART. 1148 |
| | | 3 |  With hinges - ART. 1751 Con cerniere - ART. 1751 |
| | | 4 |  With hinges - ART. 1753 Con cerniere - ART. 1753 |
| | | 5 |  With hinges - ART. 1755 Con cerniere - ART. 1755 |
| | | 6 |  With hinges - ART. 1757 Con cerniere - ART. 1757 |

EXAMPLE / ESEMPIO

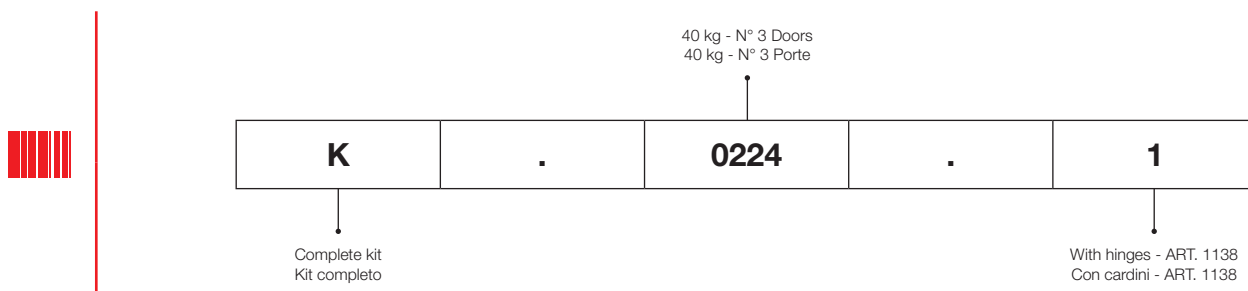

| Tracks / Binari | | ALUMINUM FINISHES CODES / CODICI FINITURE ALLUMINIO | |
|------------------------|---|---|-----------------|
| | |  | |
| CODE / CODICE | | FINISH COLOR / COLORE FINITURA | |
| 8 00 0.0 |  00 G | Raw - Mill Finish / Neutro - Grezzo | |
| 8 01 0.0 |  01 A | Anodized Silver / Argento | STANDARD |

Accordion

Accordion door
Porta pieghevole a fisarmonica

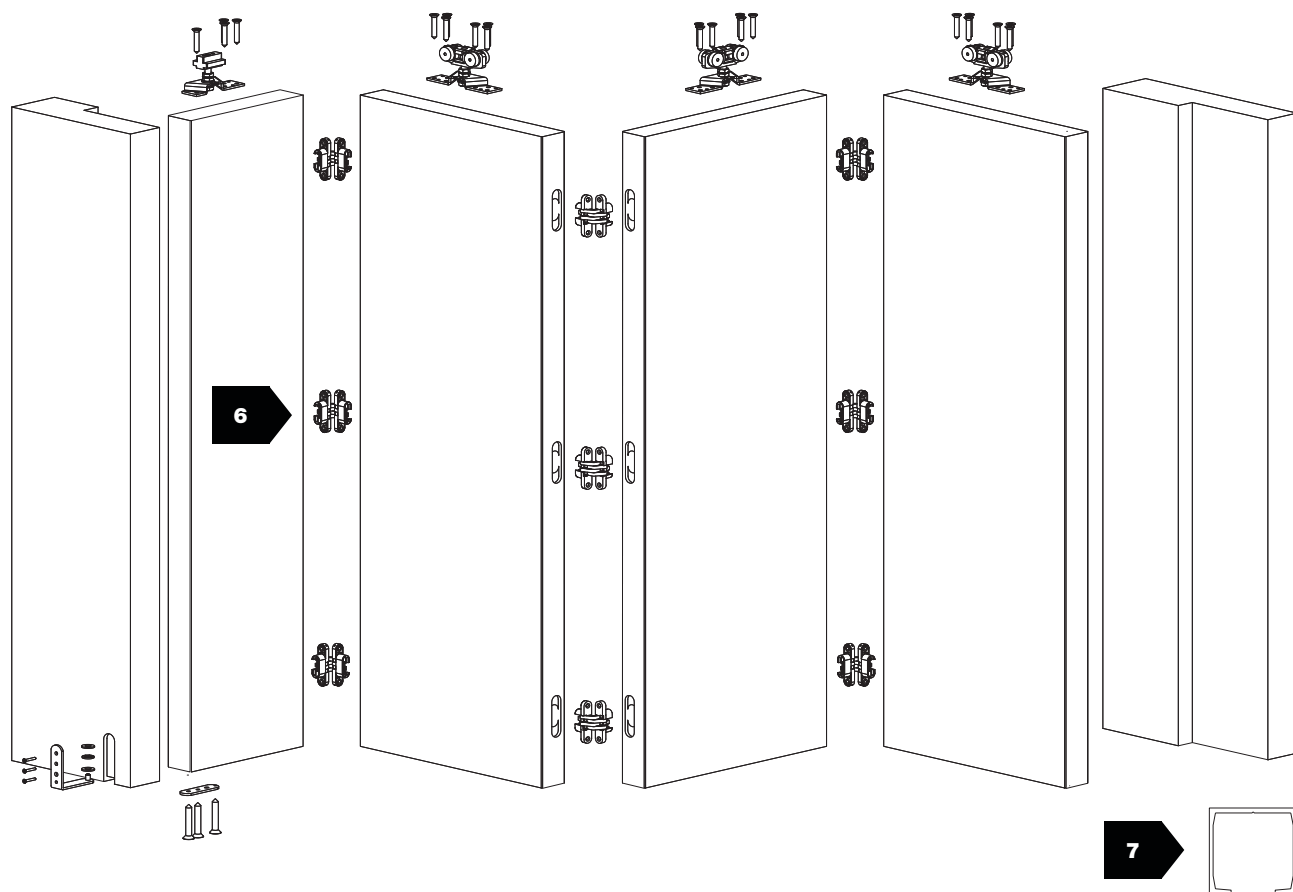
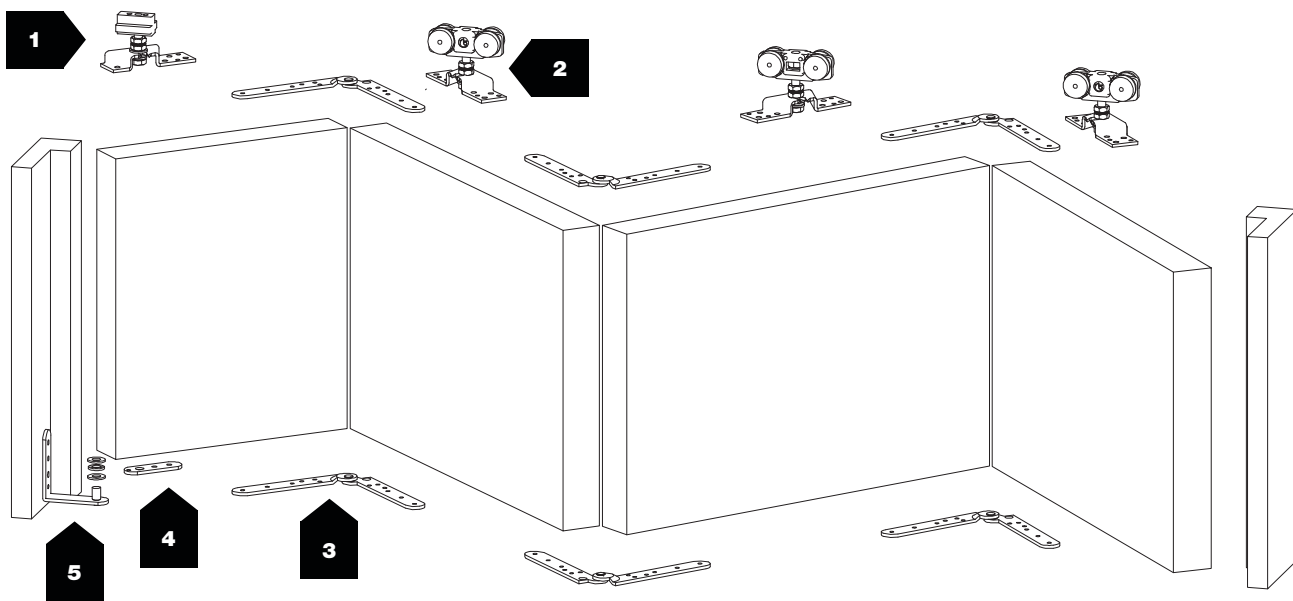







Min. 30 mm

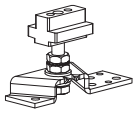

40 kg

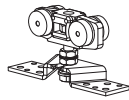
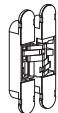
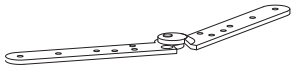

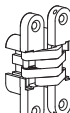
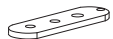
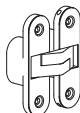
5 mm

| N° | Barcode | | kg | | N° | Barcode | | kg | |
|----|---------|---|----|--|----|---------|---|---|----|
| 1 | 1188 |  | 40 | | 5 | 1187 |  | 40 | |
| 2 | 1189 |  | 40 | | 6 | 1751/N |  | 40 | |
| 3 | 1138 |  | 40 | | | 1753/N |  | 40 | |
| | 1148 | | 40 | | | 1755/N |  | 40 | |
| 4 | 1186 |  | 40 | | | 1757/PI |  | 40 | |
| | | | | | | 7 | 1080 8 00 0.01080 8 01 0.01080 |  | 40 |

Accordion

Accordion door
Porta pieghevole a fisarmonica

40 kg
(each door / per porta)

3 doors
3 porte

With hinges
Con cardini

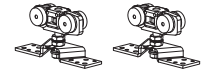
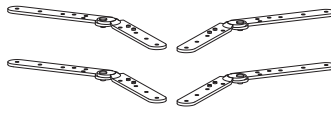
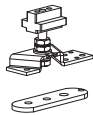
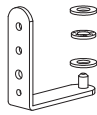

| OLD CODE | NEW CODE |  |  |
|--------------|----------|---|---|
| 1188/1138/3P | K.0224.1 | Close up doors / Ante ravvicinate | 4x |
| 1188/1148/3P | K.0224.2 | Spaced doors / Ante distanziate | 4x |

40 kg
(each door / per porta)

4 doors
4 porte

With hinges
Con cardini

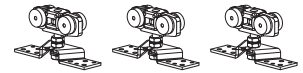
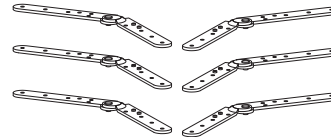
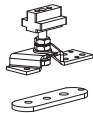
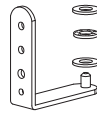

| OLD CODE | NEW CODE |  |  |
|--------------|----------|---|---|
| 1188/1138/4P | K.0223.1 | Close up doors / Ante ravvicinate | 4x |
| 1188/1148/4P | K.0223.2 | Spaced doors / Ante distanziate | 4x |

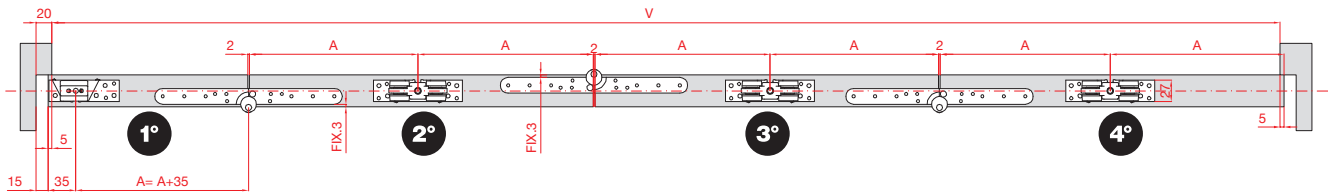

DRILLING / FORATURA



ART.1080

8 00 0.01080

8 01 0.01080

3 DOORS / PORTE - 40 KG (EACH DOOR / PER PORTA)
A=V+5+5-2-2-35:5



4 DOORS / PORTE - 40 KG (EACH DOOR / PER PORTA)
A= V+5+5-2-2-35:7

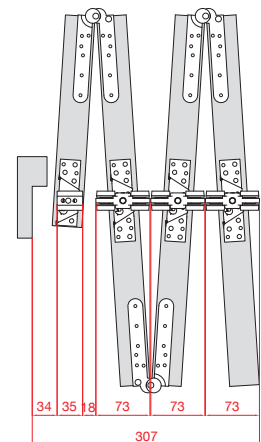
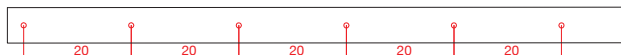

COMPOSITION FOR ACCORDION DOORS / COMPOSIZIONI PER PORTE A FISARMONICA

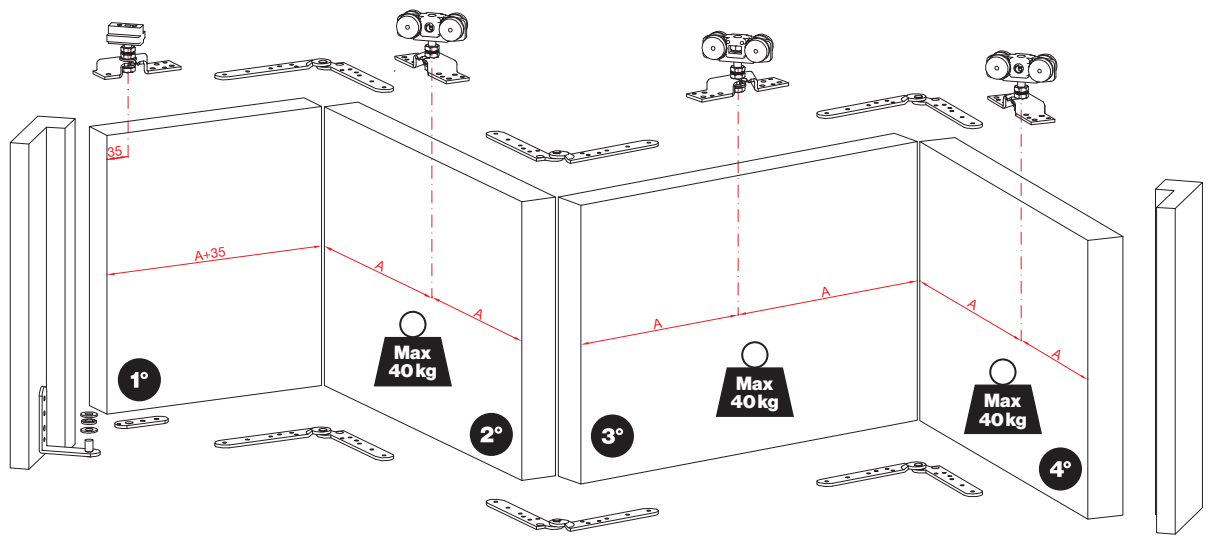

**TIGHTEN THE NUTS
SERRARE I DADI**

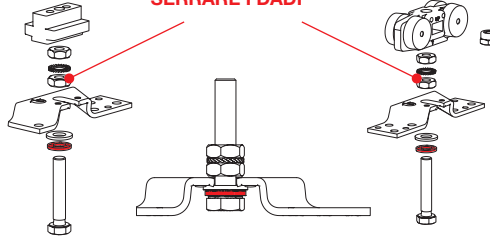

**LEAVE A SMALL SPACE FOR ROTATION
LASCIARE UN PICCOLO SPAZIO PER LA ROTAZIONE**

DIAGRAM FOR MOUNTING ACCESSORIES / SCHEMA DI MONTAGGIO ACCESSORI

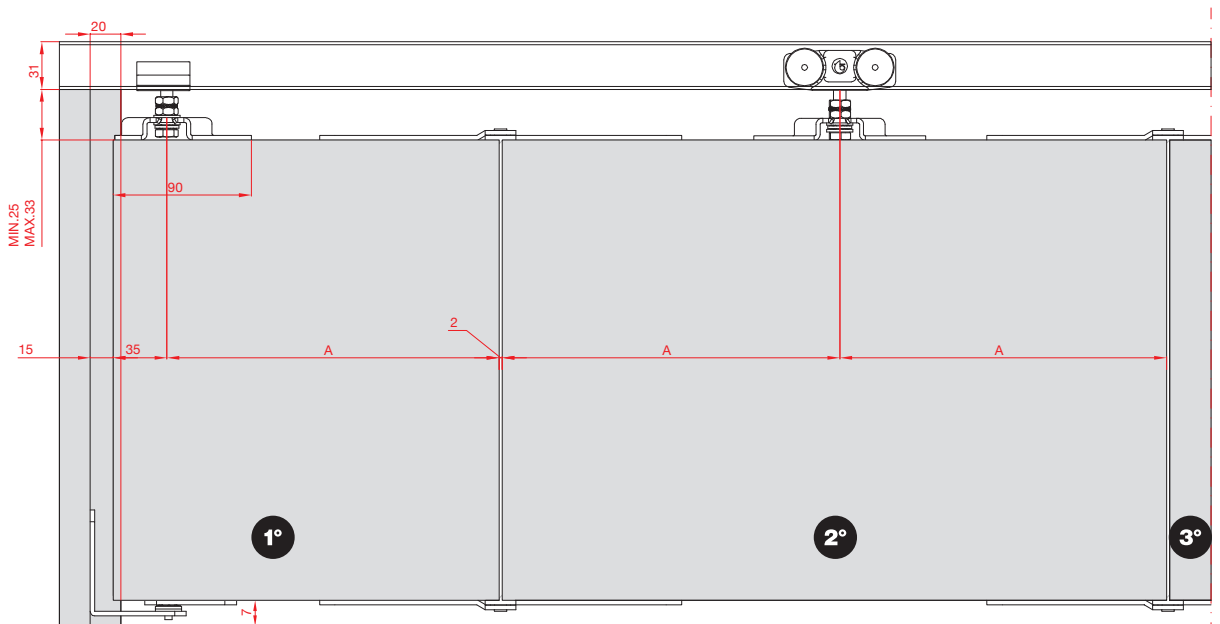

**1° HALF DOOR + 35 mm / 2° WHOLE DOOR / 3° WHOLE DOOR
1° MEZZA PORTA + 35 mm / 2° PORTA INTERA / 3° PORTA INTERA**

Accordion

Accordion door
Porta pieghevole a fisarmonica



40 kg
(each door / per porta)



3 doors
3 porte



With hinges
Con cerniere

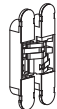
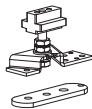
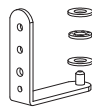

N°6
HINGES / CERNIERE ART. 1751

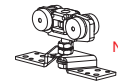

N°2

| OLD CODE | NEW CODE |  |
|----------------|----------|---|
| 1188/1751/N/3P | K.0224.3 | 4x |

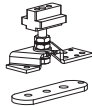
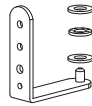

N°6
HINGES / CERNIERE ART. 1753

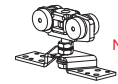

N°2

| OLD CODE | NEW CODE |  |
|----------------|----------|---|
| 1188/1753/N/3P | K.0224.4 | 4x |

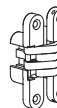
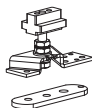
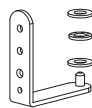

N°6
HINGES / CERNIERE ART. 1755

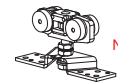

N°2

| OLD CODE | NEW CODE |  |
|----------------|----------|---|
| 1188/1755/N/3P | K.0224.5 | 4x |

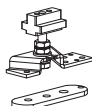
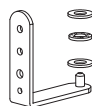

N°6
HINGES / CERNIERE ART. 1757



N°2

| OLD CODE | NEW CODE |  |
|-----------------|----------|---|
| 1188/1757/PI/3P | K.0224.6 | 4x |



40 kg
(each door / per porta)



4 doors
4 porte



With hinges
Con cerniere

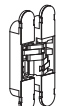
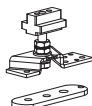
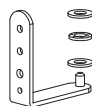

N°9
HINGES / CERNIERE ART. 1751

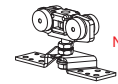

N°3

| OLD CODE | NEW CODE |  |
|----------------|----------|---|
| 1188/1751/N/4P | K.0223.3 | 4x |

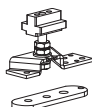
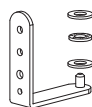

N°9
HINGES / CERNIERE ART. 1753

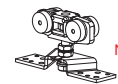

N°3

| OLD CODE | NEW CODE |  |
|----------------|----------|---|
| 1188/1753/N/4P | K.0223.4 | 4x |

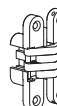
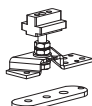
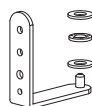

N°9
HINGES / CERNIERE ART. 1755



N°3

| OLD CODE | NEW CODE |  |
|----------------|----------|---|
| 1188/1755/N/4P | K.0223.5 | 4x |

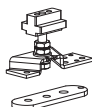
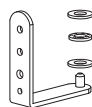

N°9
HINGES / CERNIERE ART. 1757



N°3

| OLD CODE | NEW CODE |  |
|-----------------|----------|---|
| 1188/1757/PI/4P | K.0223.6 | 4x |

COMPOSITION FOR ACCORDION DOORS / COMPOSIZIONI PER PORTE A FISARMONICA

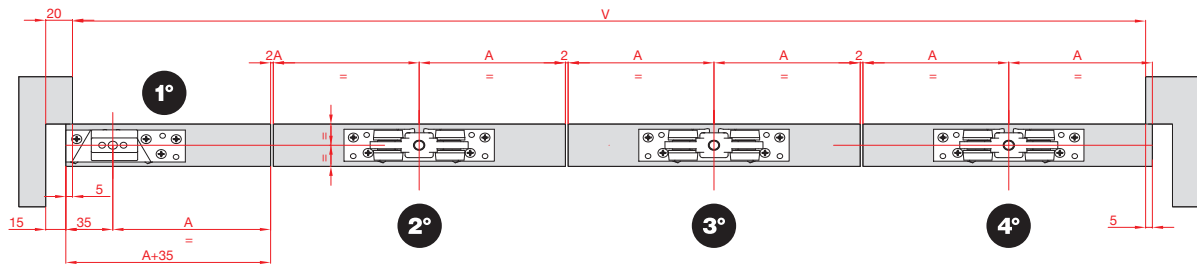
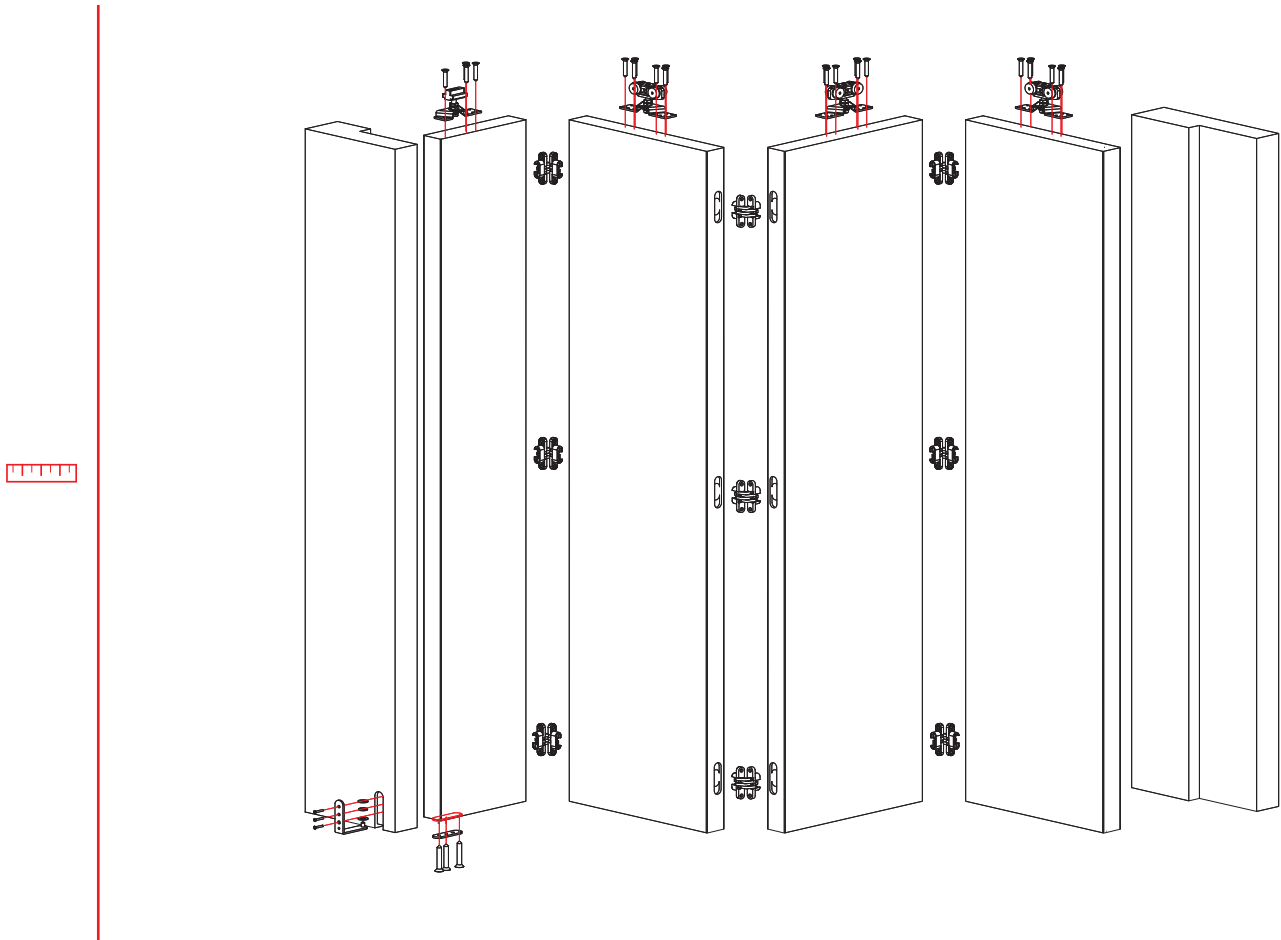

DRILLING / FORATURA



ART.1080
8 00 0.01080
8 01 0.01080



3 DOORS / PORTE - 40 KG (EACH DOOR / PER PORTA)
 $A=V+5+5-2-2-35:5$

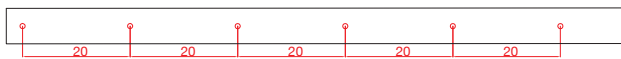

4 DOORS / PORTE - 40 KG (EACH DOOR / PER PORTA)
 $A=V+5+5-2-2-35:7$

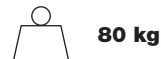
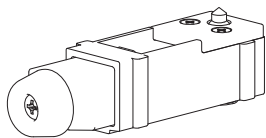

| OLD CODE | NEW CODE | The Push&Go bumper can be used with any stopper, trolley and clamp. Il respingente Push&Go può essere utilizzato con qualsiasi fermo, scorrevole e ganascia. |
|----------|------------|---|
| 101/80/G | S.101/80/G | |

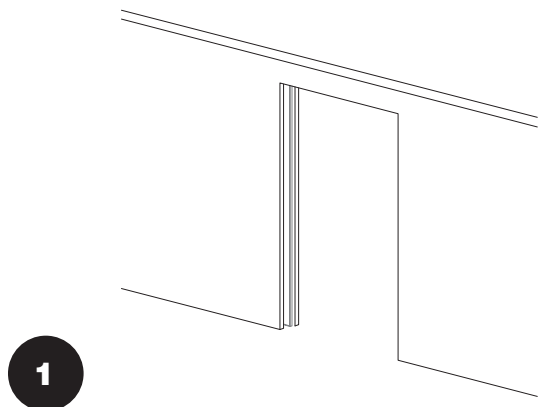

1
The **Push&Go** bumper allows complete door opening.
Il respingente **Push&Go** permette di aprire completamente la porta.

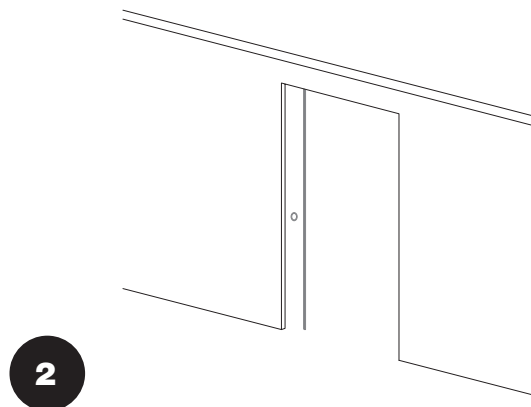

2
With simple pressure the door will be partially released, getting out from wall.
Con una semplice pressione la porta fuoriesce parzialmente.

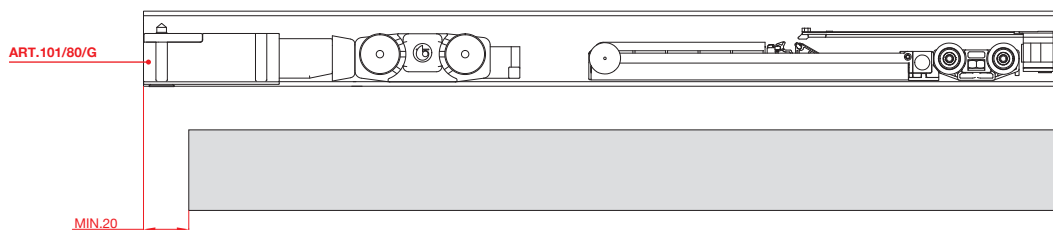

**ALUMINIUM TRACKS SUITABLE FOR THE PUSH&GO BUMPER
BINARI IN ALLUMINIO ADATTI AL RESPINGENTE PUSH & GO**

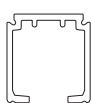

ART. 1280
8 00 0 .01280
8 01 0 .01280

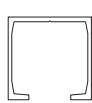

ART. 1080
8 00 0 .01080
8 01 0 .01080

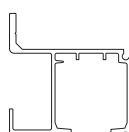

ART. 1359
8 00 0 .01359
8 01 0 .01359

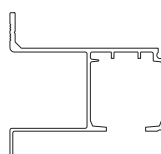

ART. 1559
8 00 0 .01559
8 01 0 .01559

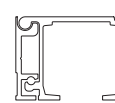

ART. 1700 + 1720
8 00 0 .01700
8 01 0 .01700
8 00 0 .01720
8 01 0 .01720

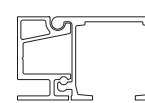

ART. 1700 + 1710
8 00 0 .01700
8 01 0 .01700
8 00 0 .01710
8 01 0 .01710

Push Magnetic Bumper Respingente



80 kg



Patented system
Sistema brevettato

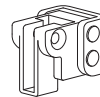
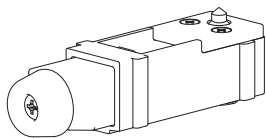

| OLD CODE | NEW CODE | OLD CODE | NEW CODE |
|----------|------------|----------|----------|
| 106/80/G | S.106/80/G | 2411 | S.2411 |

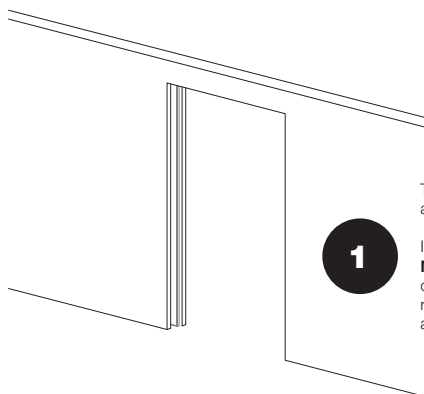

1

The **Push Magnetic** bumper allows complete door opening.

Il respingente **Push Magnetic** permette di aprire completamente la porta rimanendo magneticamente agganciata.

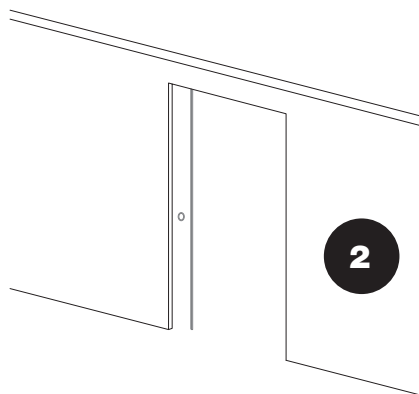

2

With simple pressure the door come out partially.

Con una semplice pressione la porta fuoriesce parzialmente.

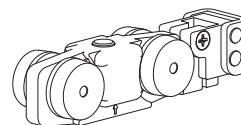
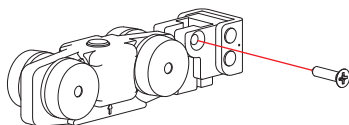
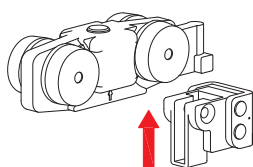
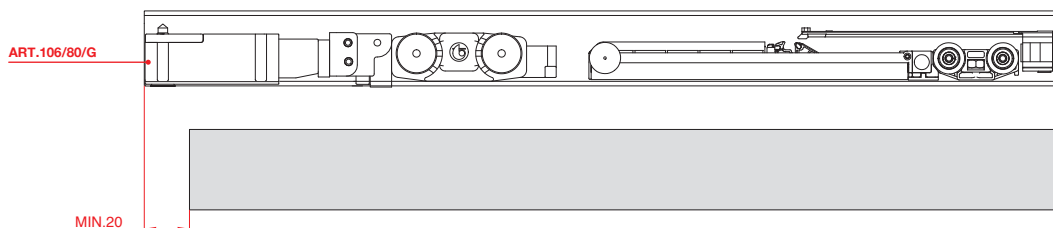

The **Push Magnetic** bumper can be adapted to already existing stoppers.
Il respingente **Push Magnetic** può essere adattato su scorrevoli per fermi standard già esistenti.

ALUMINIUM TRACKS SUITABLE TO PUSH MAGNETIC BUMPER BINARI IN ALLUMINIO ADATTI AL RESPINGENTE PUSH MAGNETIC

| | | | | | |
|---------------|---------------|---------------|---------------|------------------|------------------|
| | | | | | |
| ART. 1280 | ART. 1080 | ART. 1359 | ART. 1559 | ART. 1700 + 1720 | ART. 1700 + 1710 |
| 8 00 0 .01280 | 8 00 0 .01080 | 8 00 0 .01359 | 8 00 0 .01559 | 8 00 0 .01700 | 8 00 0 .01700 |
| 8 01 0 .01280 | 8 01 0 .01080 | 8 01 0 .01359 | 8 01 0 .01559 | 8 01 0 .01700 | 8 01 0 .01700 |
| | | | | 8 00 0 .01720 | 8 00 0 .01710 |
| | | | | 8 01 0 .01720 | 8 01 0 .01710 |



AluFrames

Aluminium rails for counterframes
Binari in alluminio per controtelai





An easy and versatile system

AluFrames system for wooden doors is available in combination with **Evolution** series (concealed bracket sliding system) and **Classic** series (standard bracket sliding system). **AluFrames** system for glass doors is available in combination with clamps series **Vetro 24** (24 mm height glass clamps with glass drilling requirements) and **Vetro 40** (40 mm height glass clamps without any drilling requirements).

The system has a maximum load **capacity of 80 kg**.

The **AluFrames** system is **extremely easy to install and also easy to be inspected** (because the door is very easy to be dismantled without breaking the plasterboard): the magnetic **Push Magnetic** system allows to combine the soft closing function and at the same time facilitates opening when the door is completely open.

Un sistema facile e versatile

Il sistema **AluFrames** per porte in legno è disponibile con le nostre staffe serie **Evolution** (sistema scorrevole con staffa invisibile) e **Classic** (sistema scorrevole con staffa tradizionale).

Il sistema **AluFrames** per porte in vetro è disponibile con le nostre pinze **Vetro 24** (accessori per porte in vetro con forature e pinza alta 24 mm) e **Vetro 40** (accessori per porte in vetro senza forature e pinza alta 40 mm).

Il sistema è realizzato per portate **fino a 80 kg**.

Il sistema **AluFrames** è estremamente **facile da montare**, di **rapida installazione e di facile ispezione**: il sistema con respingenti **Push Magnetic** combina il funzionamento di fermo e di apertura per porta totalmente aperta.





| AluFrames | | COMPLETE BOX KIT / KIT COMPLETO IN SCATOLA | |
|-----------|---|--|--|
| K | Complete kit / Kit completo | | |
| 0143 | Slides & counterframes kit - Wood - Classic Bracket Kit scorrevoli e controlelai - Staffa Classic - Legno | | |
| 0144 | Slides & counterframes kit - Wood - Evolution Bracket Kit scorrevoli e controlelai - Staffa Evolution - Legno | | |
| 0146 | Glass thickness 8-8,7 mm (5/16") / 10-10,7 mm (3/8") / 12-12,7 mm (1/2") Spessore vetro 8-8,7 mm (5/16") / 10-10,7 mm (3/8") / 12-12,7 mm (1/2") | | |
| 0147 | Counterframes kit (Pocket) - Evolution • Vetro 24 • Vetro 40 Kit controlelai (Pocket) - Evolution • Vetro 24 • Vetro 40 | | |
| | | | |
| | | 8 | N.1 Fluid damper + N.1 Push Magnetic N.1 Fermo ammortizzato Fluid + N.1 Push Magnetic |
| | | 9 | N.1 Shock absorber + N.1 Push Magnetic N.1 Fermo a pinza ammortizzati + N.1 Push Magnetic |
| | | A | ART. 3340 Track / Estruso |
| | | B | ART. 3300 Track / Estruso |
| | | C | ART. 3310 Track / Estruso |
| | | D | ART. 3320 Track / Estruso |

EXAMPLE / ESEMPIO

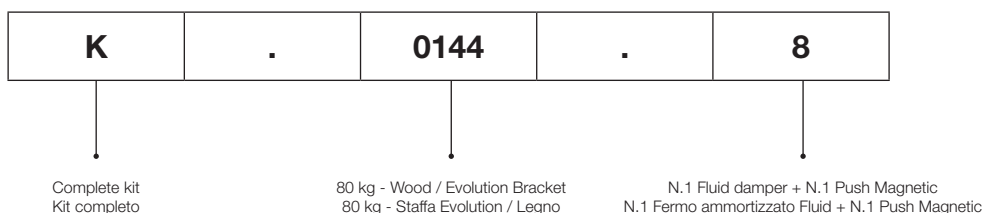

| Tracks / Binari | | ALUMINUM FINISHES CODES / CODICI FINITURE ALLUMINIO | |
|-----------------|-------------|---|----------|
| CODE / CODICE | | FINISH COLOR / COLORE FINITURA | |
| 8 00 0.0 | 00 G | Row - Mill Finish / Neutro - Grezzo | STANDARD |
| 8 01 0.0 | 01 A | Anodized Silver / Argento | |

| Tracks / Binari | | PLASTIC FINISHES CODES / CODICI FINITURE PLASTICA | |
|-----------------|--------------|---|----------|
| CODE / CODICE | | FINISH COLOR / COLORE FINITURA | |
| 8 23 0.0 | 23 GR | Gray / Grigio | STANDARD |

| Accessories / Accessori | | PLASTIC FINISHES CODES / CODICI FINITURE PLASTICA | |
|-------------------------|--------------|---|----------|
| CODE / CODICE | | FINISH COLOR / COLORE FINITURA | |
| 8 23 0.0 | 23 GR | Gray / Grigio | STANDARD |

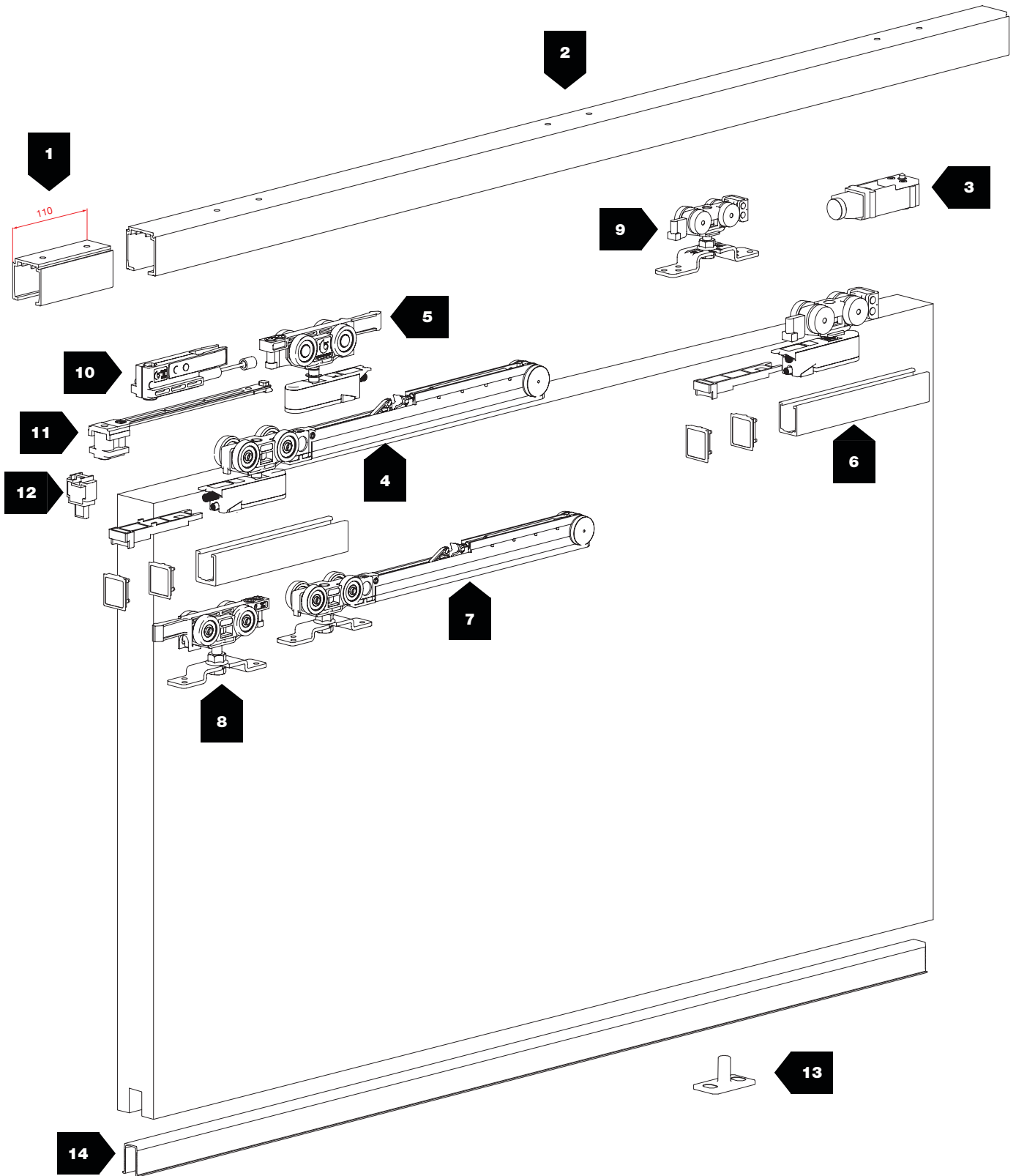











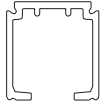
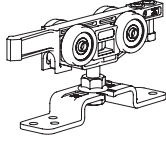

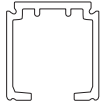
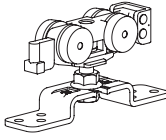
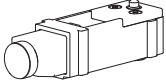
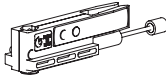

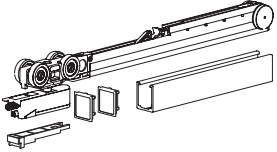
600 - 1500 mm

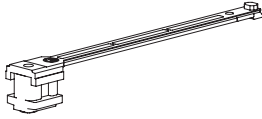

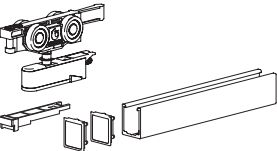
80 kg

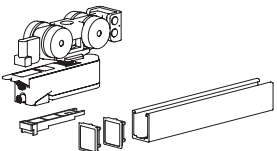

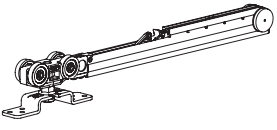
6 mm

| N° | | | kg | | N° | | | kg | |
|----|--------------------------------------|---|----|---|----|---------------------|---|----|---|
| 1 | 1280/80/F |  | — | | 8 | 3358 |  | 80 |  NEW |
| 2 | 1280 8 00 0.01280 8 01 0.01280 |  | — | | 9 | 2300/C |  | 80 | |
| 3 | 106/80/G |  | 80 | | 10 | 3355/080 |  | 80 |  NEW |
| 4 | 3362/080 |  | 80 |  NEW | 11 | 3354 |  | 80 |  NEW |
| 5 | 3368 |  | 80 |  NEW | 12 | 3347 |  | — | |
| 6 | 2300/E |  | 80 | | 13 | 3302 |  | 80 | |
| 7 | 3352/080 |  | 80 |  NEW | 14 | 121 8 23 0.00121 |  | 80 | |

AluFrames

Rails for counterframes
Binari per controtelai

FLUID

 N.1 Fluid damper
N.1 Fermo ammortizzato
Fluid

FLUID

 Bumper / Respingente
Push Magnetic



Ball bearings
Cuscinetti a sfera

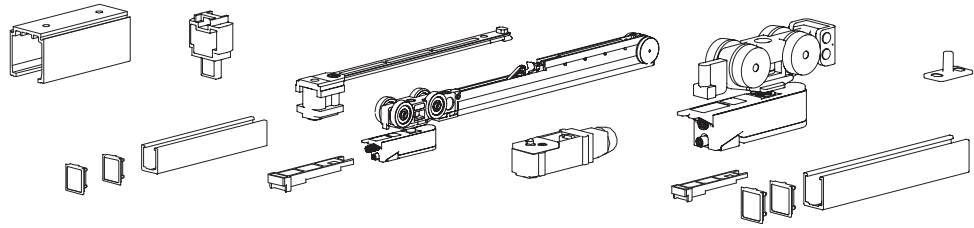

| OLD CODE | NEW CODE |  |  |  |  |
|----------|-----------------|---|---|---|---|
| — | K.0144.8 | EVOLUTION | Min. 700 mm | 80 kg | 4x |

FLUID

 N.1 Shock absorber
N.1 Fermo a pinza
ammortizzato

 Bumper / Respingente
Push Magnetic



Ball bearings
Cuscinetti a sfera

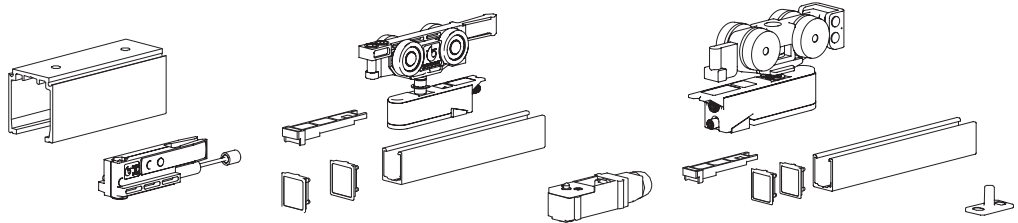

| OLD CODE | NEW CODE |  |  |  |  |
|----------|-----------------|--|--|--|--|
| — | K.0144.9 | EVOLUTION | Min. 600 mm | 80 kg | 5x |

FLUID

 N.1 Fluid damper
N.1 Fermo ammortizzato
Fluid

FLUID

 Bumper / Respingente
Push Magnetic



Ball bearings
Cuscinetti a sfera

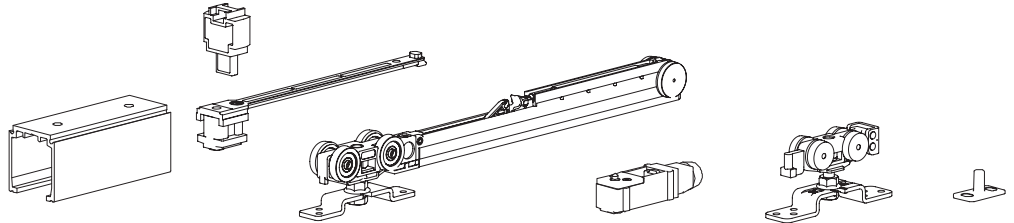

| OLD CODE | NEW CODE |  |  |  |  |
|----------|-----------------|---|---|---|---|
| — | K.0143.8 | CLASSIC | Min. 700 mm | 80 kg | 4x |

FLUID

 N.1 Shock absorber
N.1 Fermo a pinza
ammortizzato

 Bumper / Respingente
Push Magnetic



Ball bearings
Cuscinetti a sfera

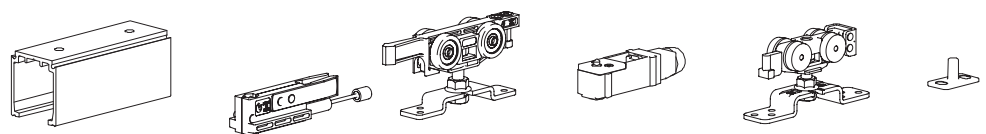

| OLD CODE | NEW CODE |  |  |  |  |
|----------|-----------------|---|---|---|---|
| — | K.0143.9 | CLASSIC | Min. 600 mm | 80 kg | 5x |

ALUMINIUM RAIL FOR COUNTERFRAMES / BINARIO IN ALLUMINIO PER CONTROL ELAI

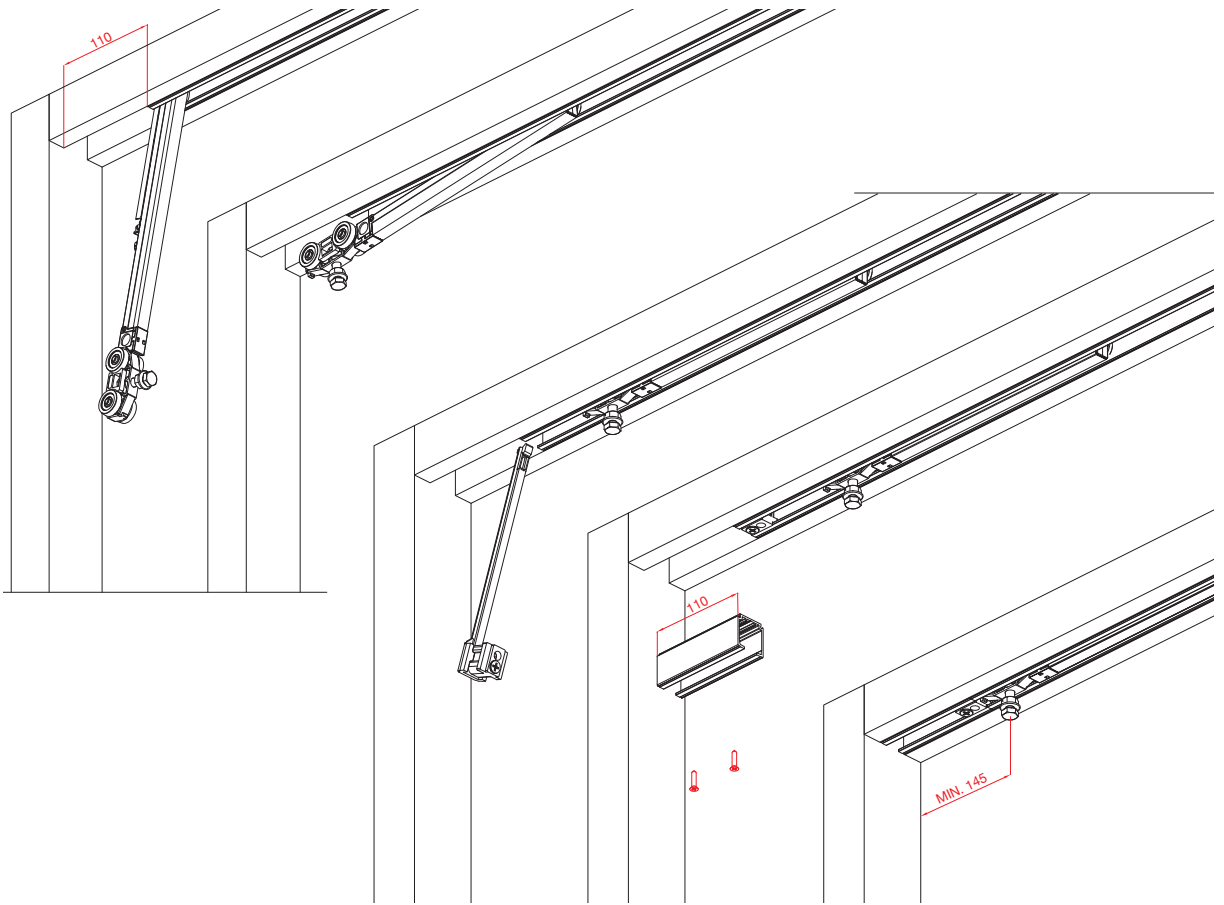

FLUID DAMPER / FERMO AMMORTIZZATO FLUID

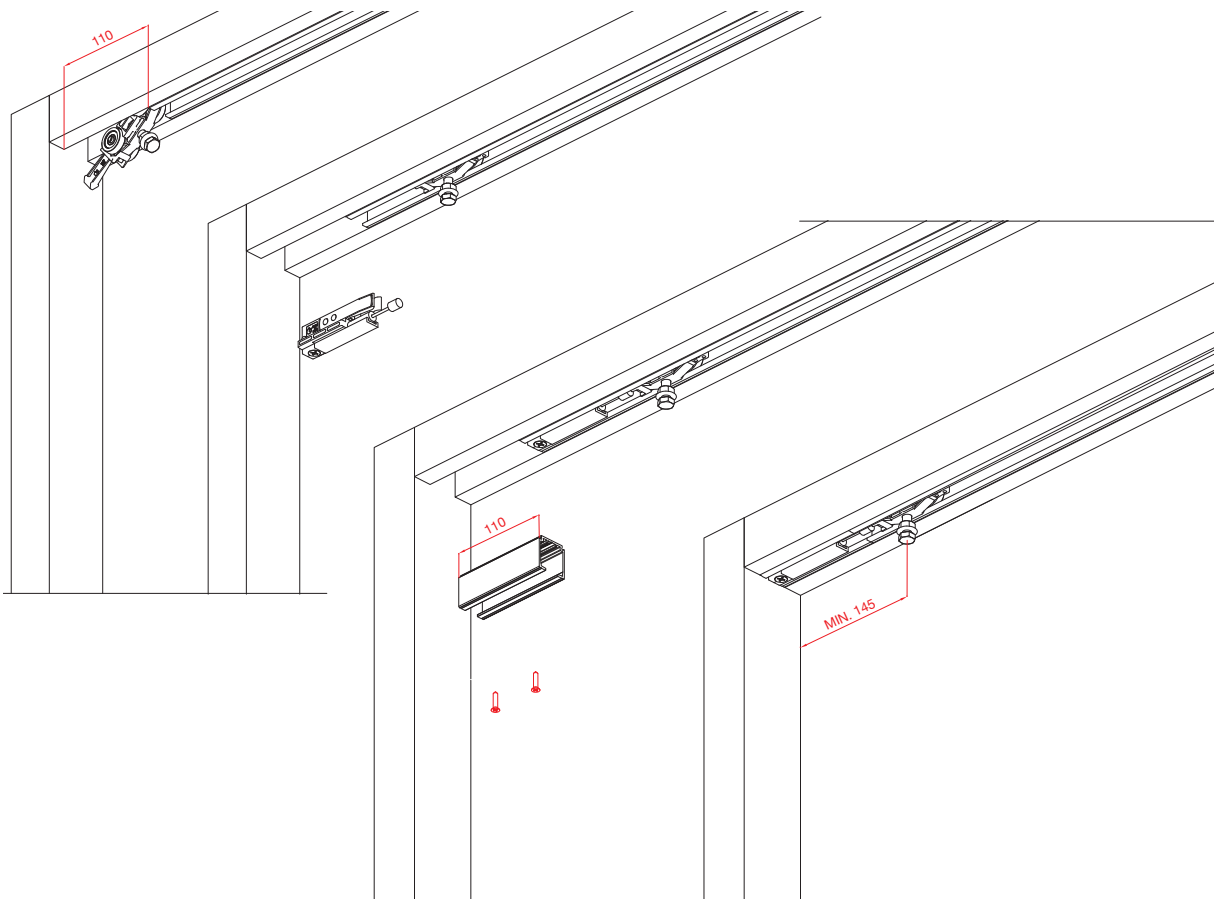

SHOCK ABSORBER / FERMO A PINZA AMMORTIZZATO

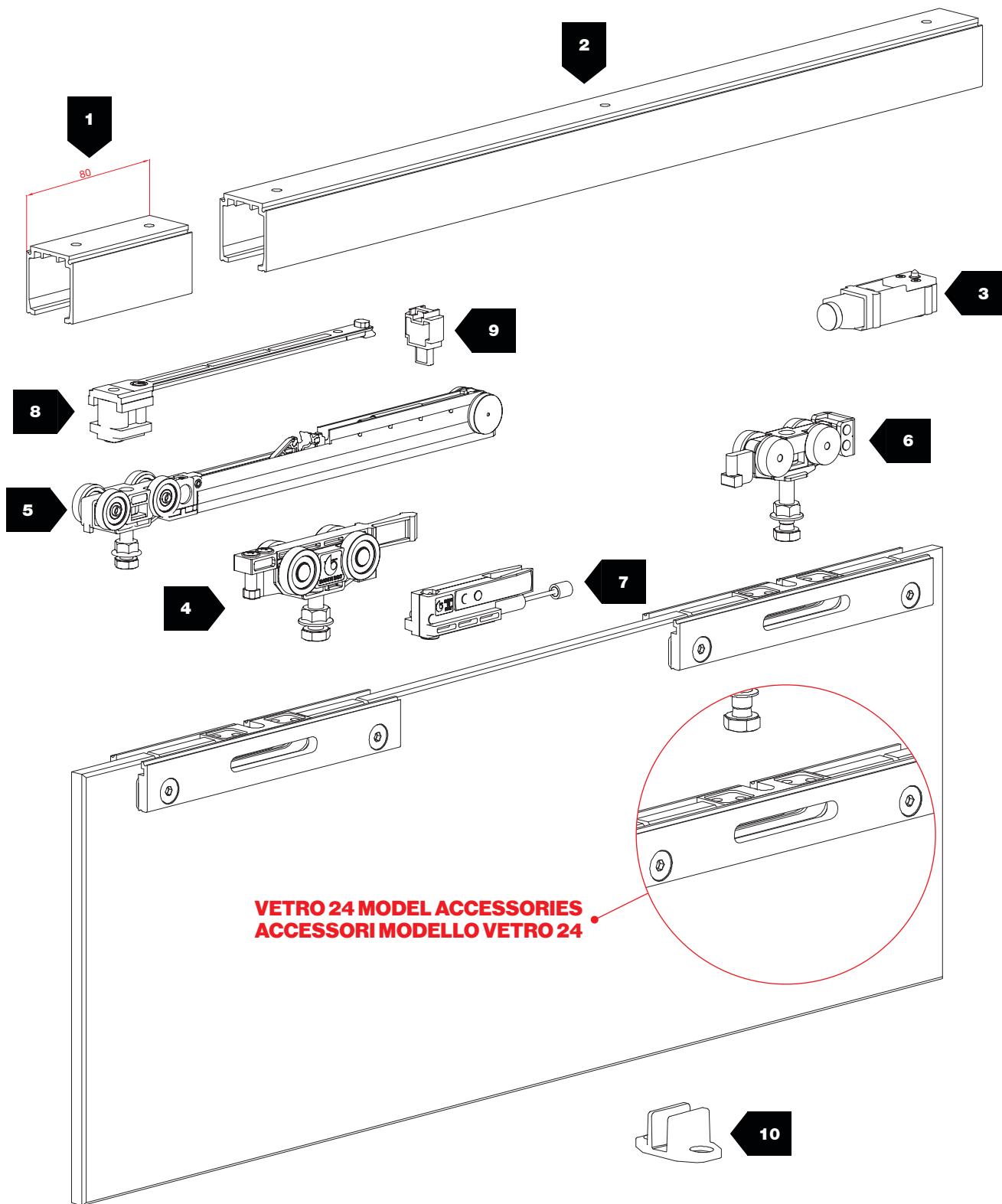









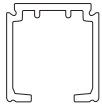
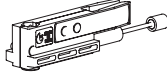

600 ÷ 1500 mm

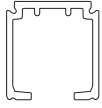
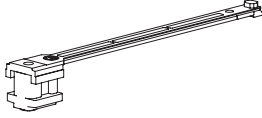

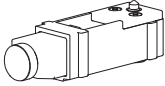
80 kg

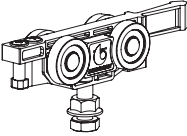

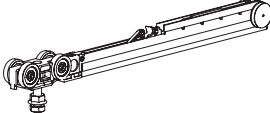

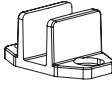
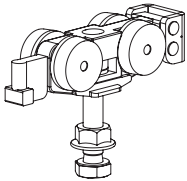
10 mm

| N° | Barcode | | kg | | N° | Barcode | | kg | |
|----|--------------------------------------|---|----|---|----|----------|---|----|---|
| 1 | 1280/80/F |  | — | | 7 | 3355/080 |  | 80 |  NEW |
| 2 | 1280 8 00 0.01280 8 01 0.01280 |  | — | | 8 | 3354 |  | 80 |  NEW |
| 3 | 106/80/G |  | 80 | | 9 | 3347 |  | — | |
| 4 | 3358/V24 |  | 80 |  NEW | 10 | 118 | | 80 | Glass thk. Vetri sp. 8-8,7 mm (5/16") |
| 5 | 3352/080/V24 |  | 80 |  NEW | 10 | 110 |  | 80 | Glass thk. Vetri sp. 10-10,7 mm (3/8") |
| 6 | 2403/V24 |  | 80 | | 10 | 112 | | 80 | Glass thk. Vetri sp. 12-12,7 mm (1/2") |

AluFrames

Rails for counterframes
Binari per controtelai

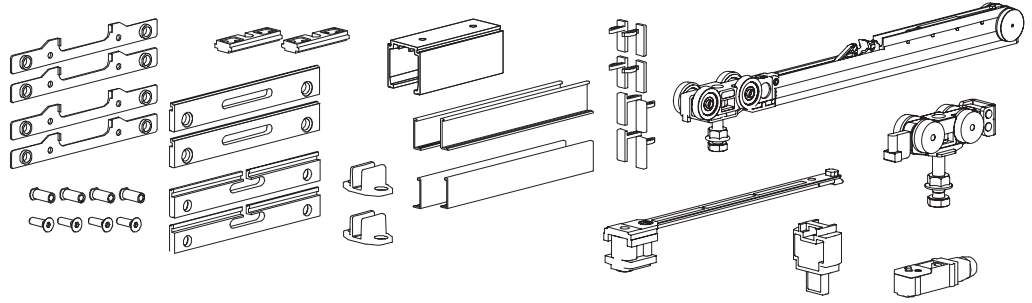

FLUID

-  N.1 Fluid damper
-  N.1 Fermo ammortizzato Fluid
-  Ball bearings
Cuscinetti a sfera



| OLD CODE | NEW CODE |  |  |  |
|----------|----------|--|---|---|
| - | K.0146.8 | Min. 650 mm | 80 kg | 4x |

FLUID

-  N.1 Shock absorber
-  N.1 Fermo a pinza ammortizzato
-  Ball bearings
Cuscinetti a sfera

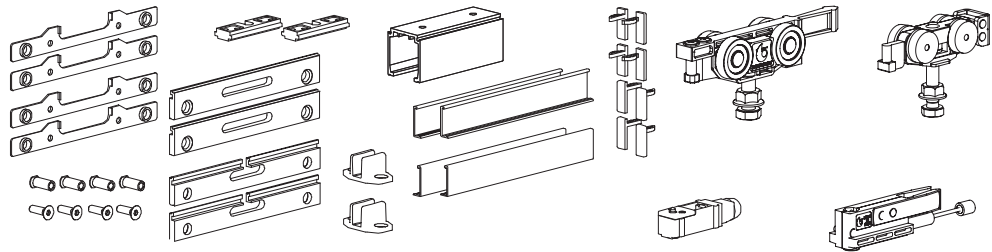

| OLD CODE | NEW CODE |  |  |  |
|----------|----------|--|---|---|
| - | K.0146.9 | Min. 600 mm | 80 kg | 5x |

OPTIONAL
+

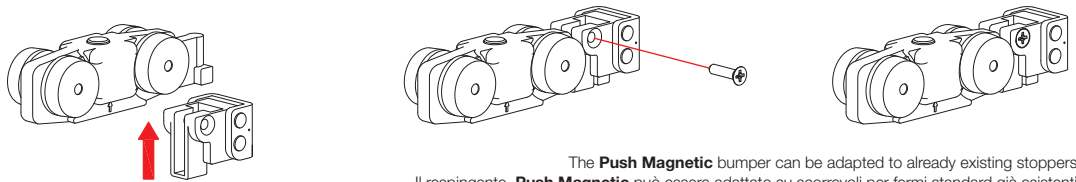

The **Push Magnetic** bumper can be adapted to already existing stoppers.
Il respingente **Push Magnetic** può essere adattato su scorrevoli per fermi standard già esistenti.

MEASUREMENTS DESCRIPTION / DESCRIZIONE MISURE

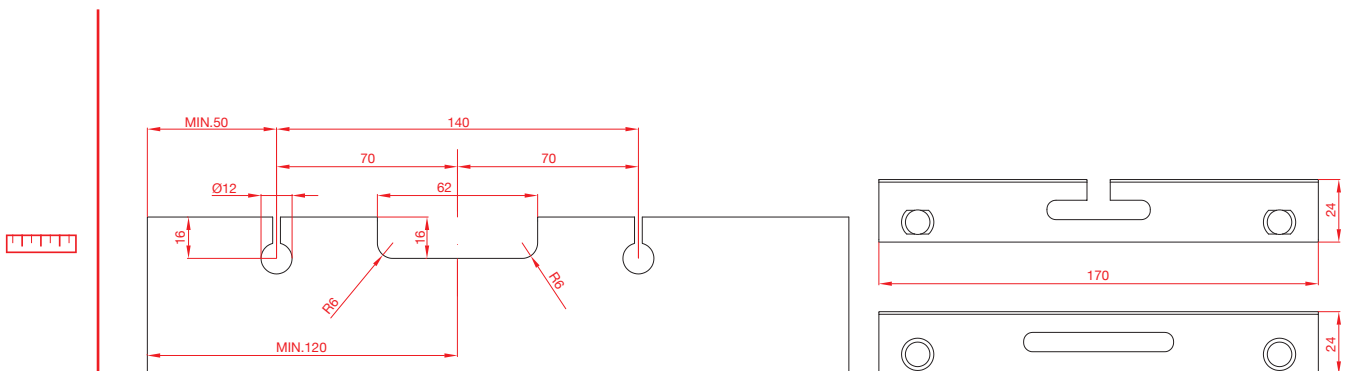

ALUMINIUM RAIL FOR COUNTERFRAMES / BINARIO IN ALLUMINIO PER CONTROLTELAI

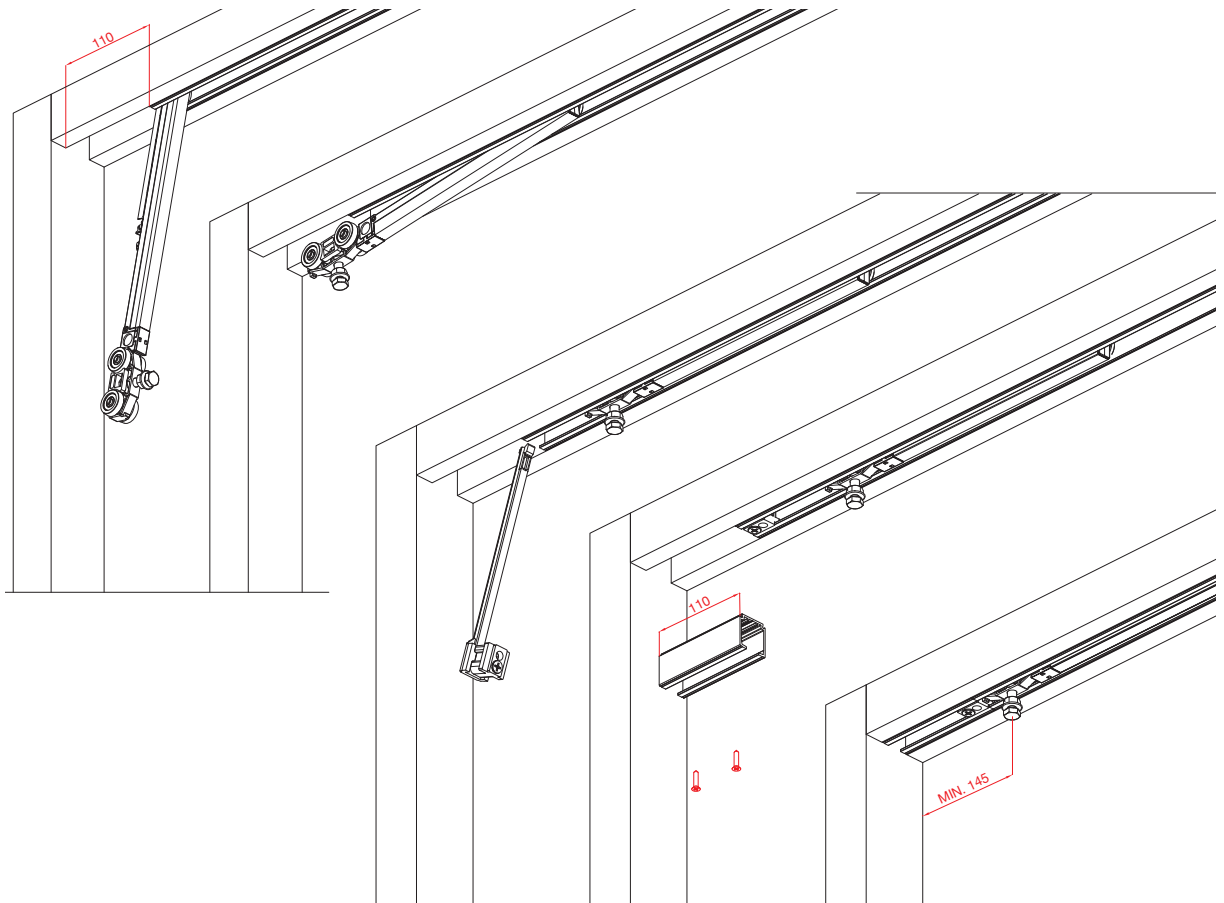

FLUID DAMPER / FERMO AMMORTIZZATO FLUID

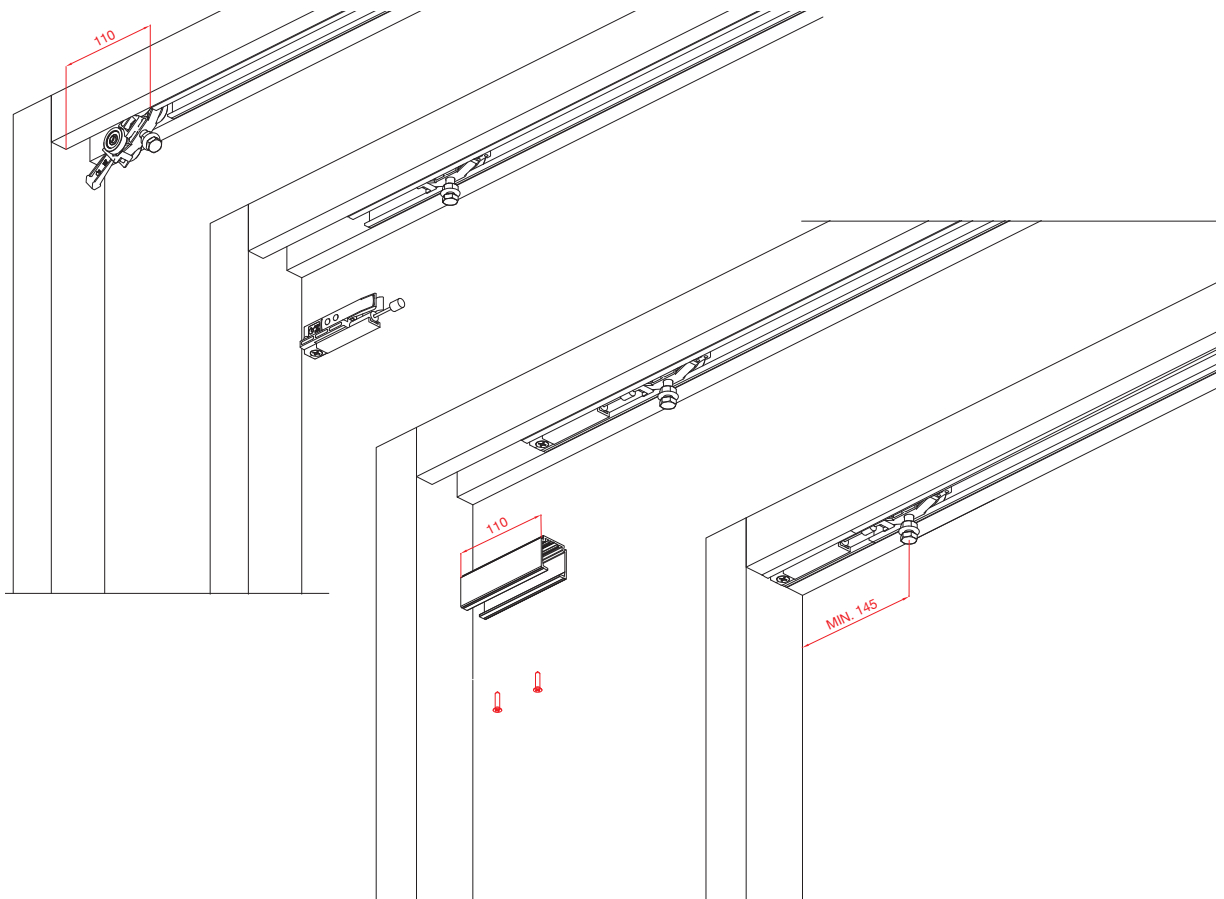

SHOCK ABSORBER / FERMO A PINZA AMMORTIZZATO

AluFrames Pocket

Rails for counterframes
Binari per controlelai

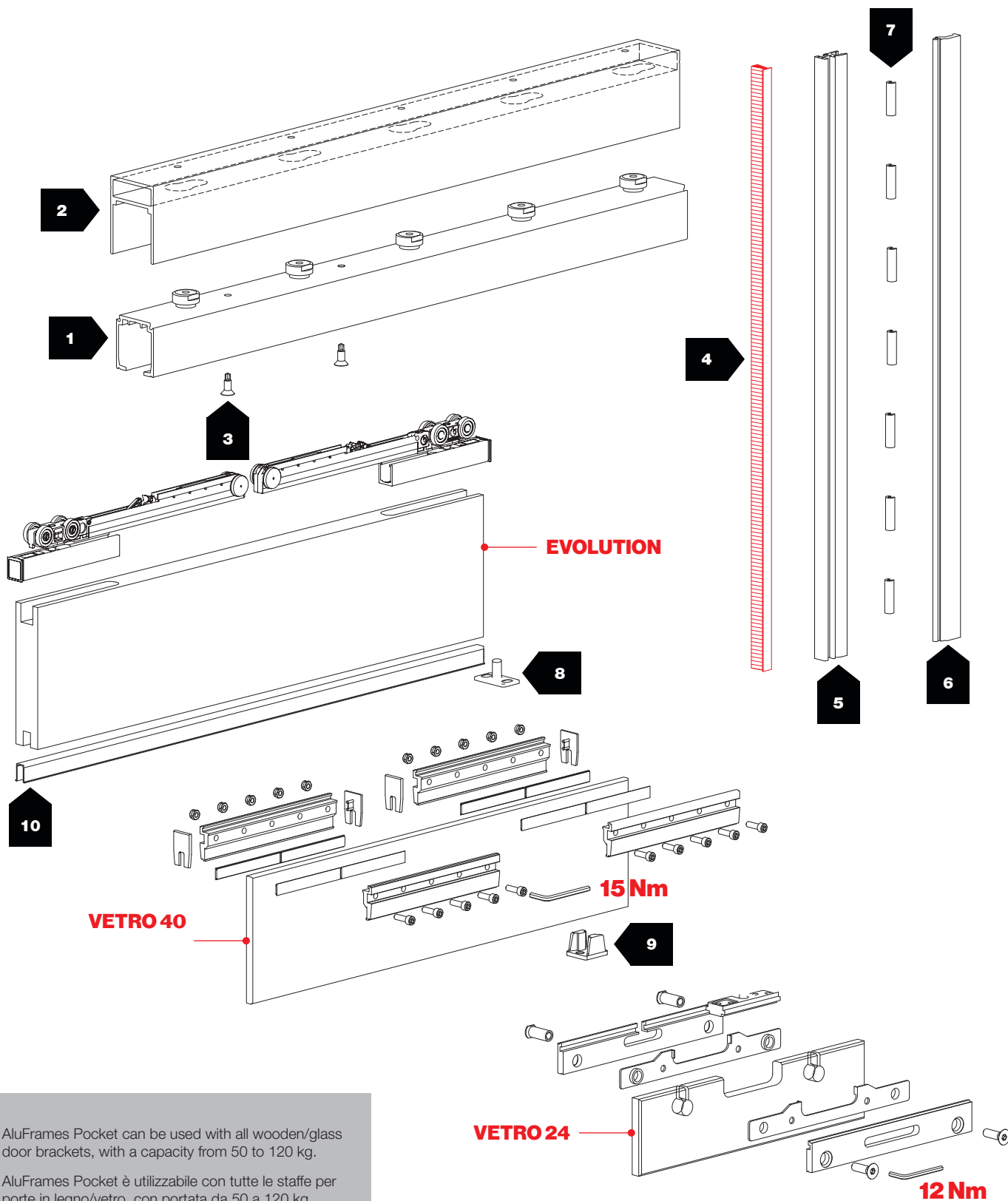

AluFrames Pocket can be used with all wooden/glass door brackets, with a capacity from 50 to 120 kg.

AluFrames Pocket è utilizzabile con tutte le staffe per porte in legno/vetro, con portata da 50 a 120 kg.











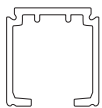

Max 1250 mm

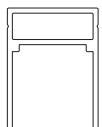

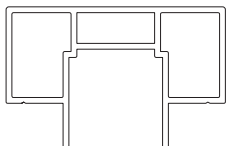
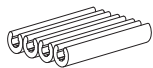
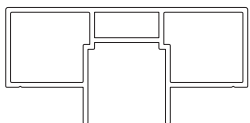
80 kg

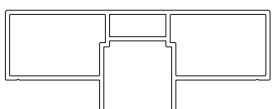
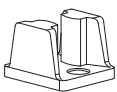

6 mm

| N° | | | kg | | N° | | | kg | |
|----|----------|---|----|---------|----|---------------------|---|---|--|
| 1 | 1280 |  | - | | 5 | 199 |  | - | |
| 2 | 3340 |  | - | | 6 | 198 |  | - | |
| | 3300 |  | - | | 7 | 1222 |  | - | |
| | 3310 |  | - | | 8 | 3302 |  | 80 | |
| | 3320 |  | - | | 9 | 3308/8 |  | 80 | Glass thk. Vetri sp. 8-8,7 mm 5/16" |
| 3 | 3306 |  | 80 | 3308/10 | | 80 | | Glass thk. Vetri sp. 10-10,7 mm 3/8" | |
| | | | | 3308/12 | | 80 | | Glass thk. Vetri sp. 12-12,7 mm 1/2" | |
| 4 | 543/11/G |  | - | | 10 | 121 8 23 0.00121 |  | 80 | |

AluFrames Pocket

Rails for counterframes
Binari per controlelai

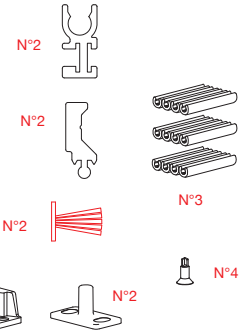
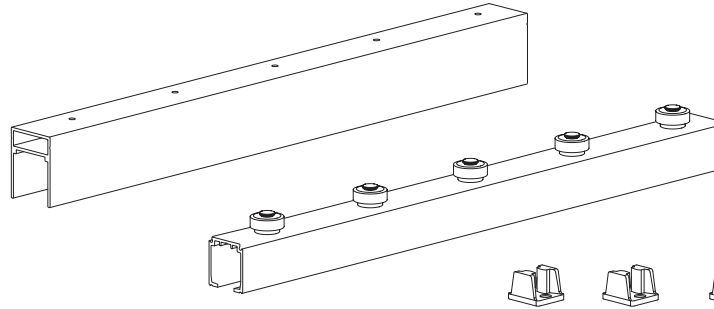
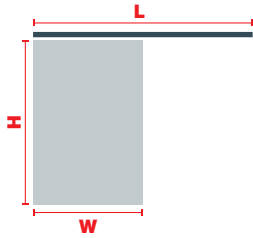

| OLD CODE | NEW CODE | W | L | H | | |
|-----------------|----------|-------------|-------------|-------------|--------------|----|
| POCKET/250/3340 | B.0147.A | Max 1250 mm | Max 2500 mm | Max 2200 mm | 80 kg | 1x |

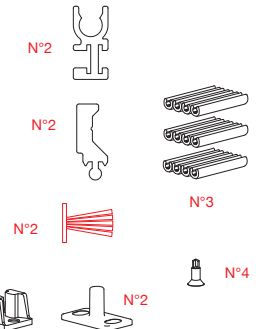
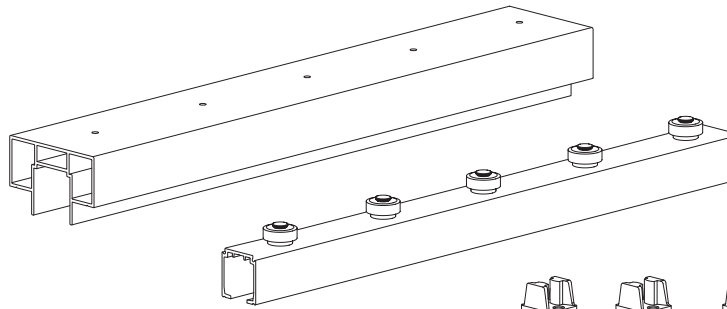
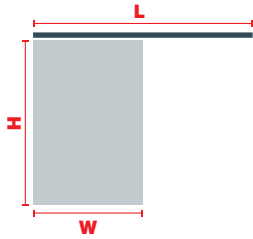

| OLD CODE | NEW CODE | W | L | H | | |
|-----------------|----------|-------------|-------------|-------------|--------------|----|
| POCKET/250/3300 | B.0147.B | Max 1250 mm | Max 2500 mm | Max 2200 mm | 80 kg | 1x |

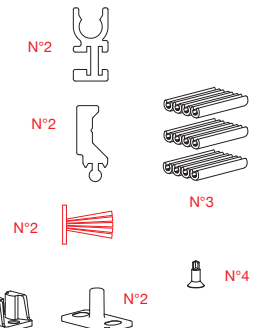
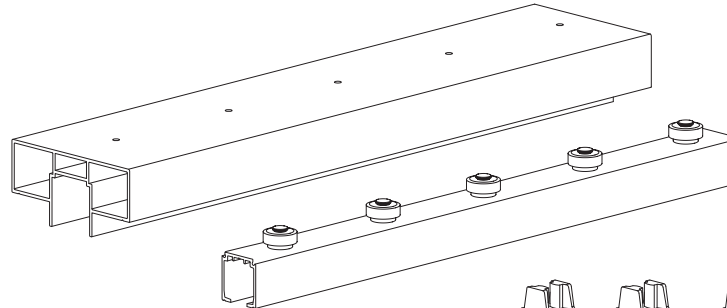
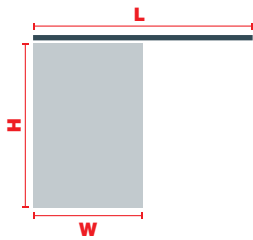

| OLD CODE | NEW CODE | W | L | H | | |
|-----------------|----------|-------------|-------------|-------------|--------------|----|
| POCKET/250/3310 | B.0147.C | Max 1250 mm | Max 2500 mm | Max 2200 mm | 80 kg | 1x |

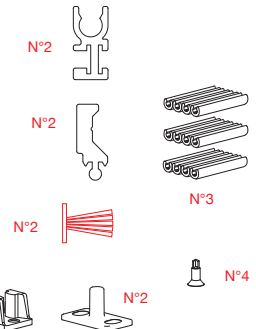
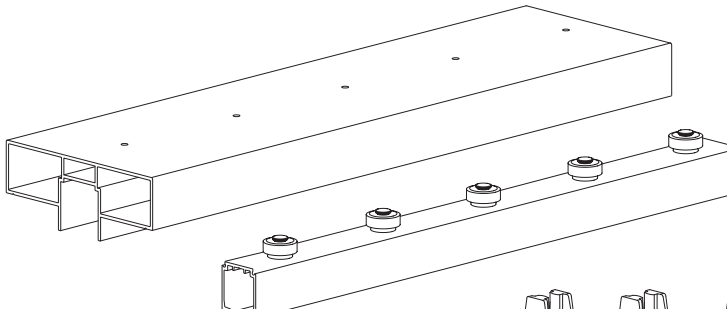
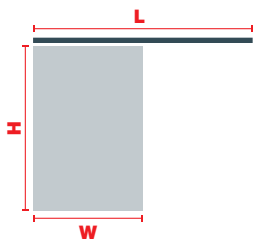

| OLD CODE | NEW CODE | W | L | H | | |
|-----------------|----------|-------------|-------------|-------------|--------------|----|
| POCKET/250/3320 | B.0147.D | Max 1250 mm | Max 2500 mm | Max 2200 mm | 80 kg | 1x |



AVAILABLE ON REQUEST L = 2000 mm E L = 3000 mm
A RICHIESTA, SONO DISPONIBILI L = 2000 mm E L = 3000 mm

ART. 3340 - MEASUREMENTS / MISURE

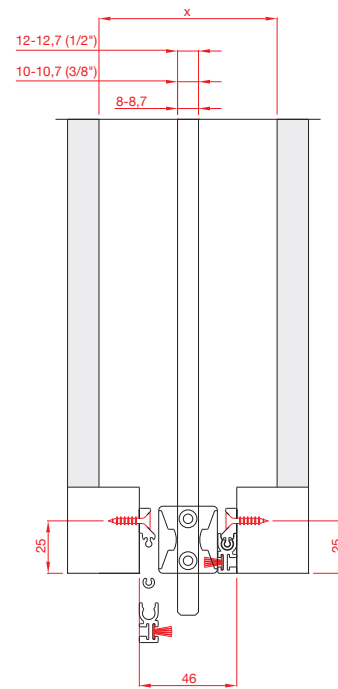
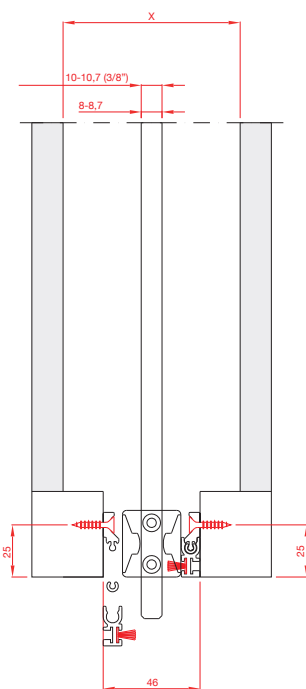
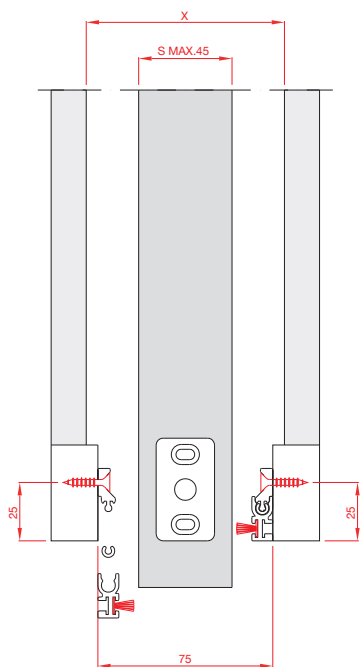
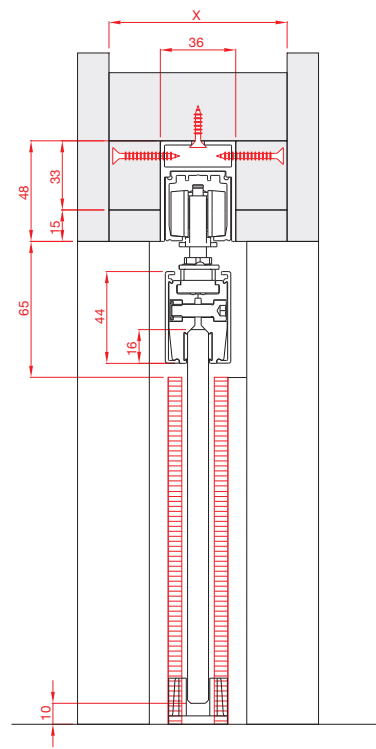
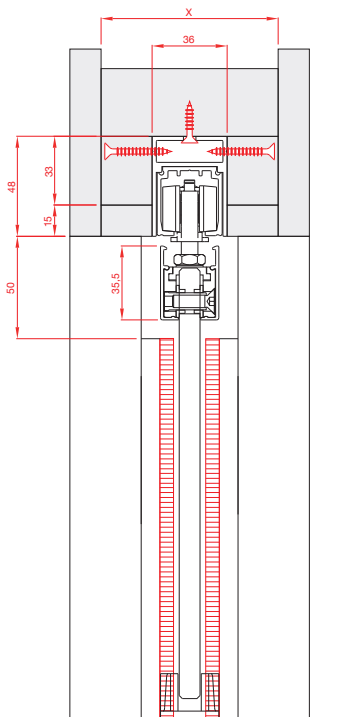
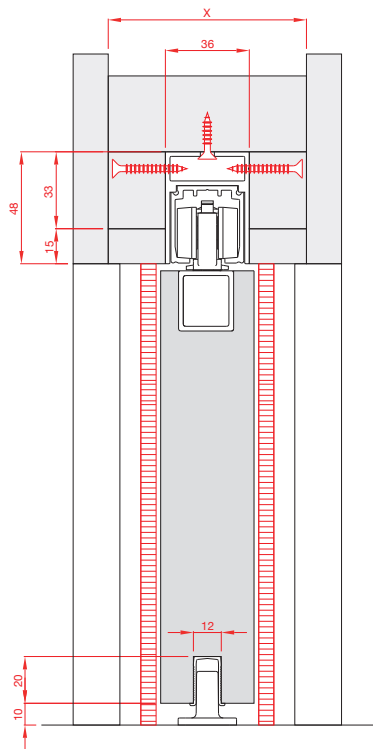

EVOLUTION
(WOOD / LEGNO)

VETRO 40
(GLASS / VETRO)

VETRO 24
(GLASS / VETRO)

ART. 3300 - MEASUREMENTS / MISURE

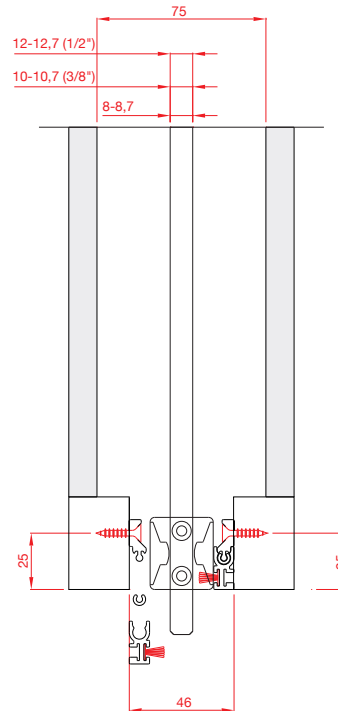
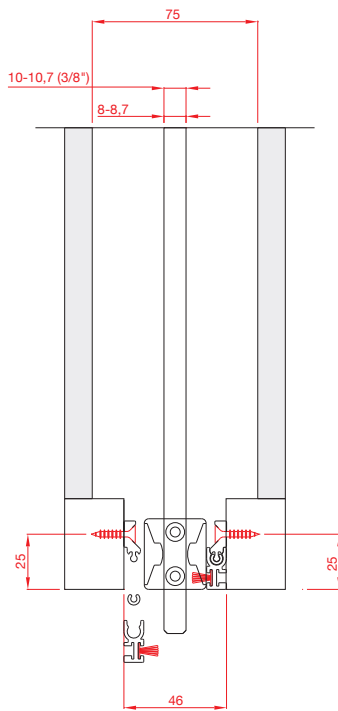
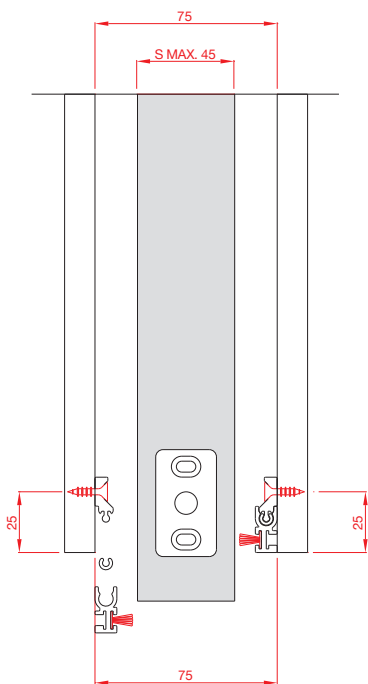
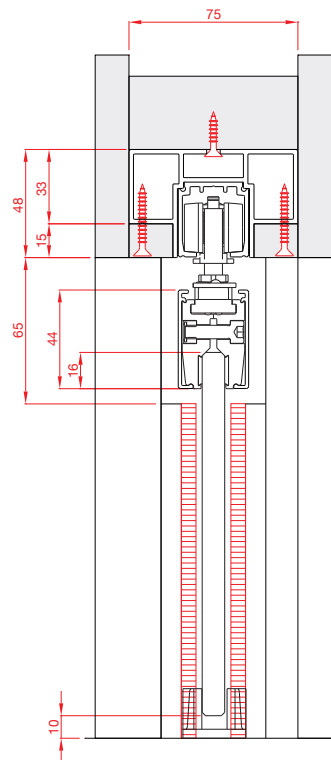
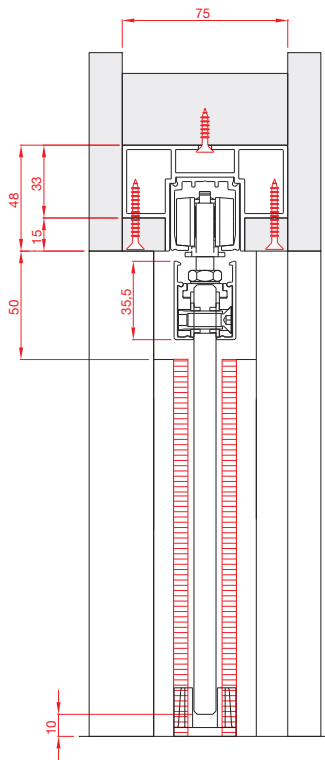
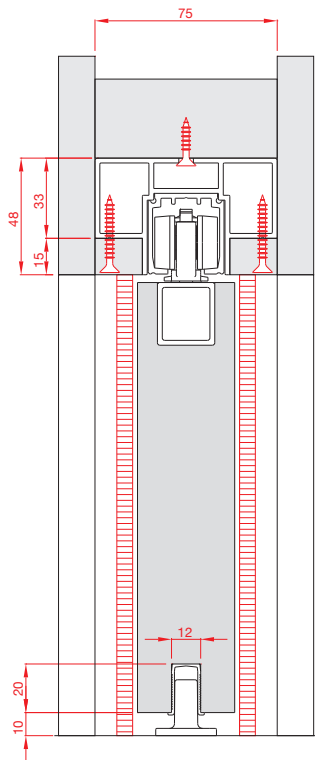

EVOLUTION
(WOOD / LEGNO)

VETRO 40
(GLASS / VETRO)

VETRO 24
(GLASS / VETRO)

ART. 3310 - MEASUREMENTS / MISURE

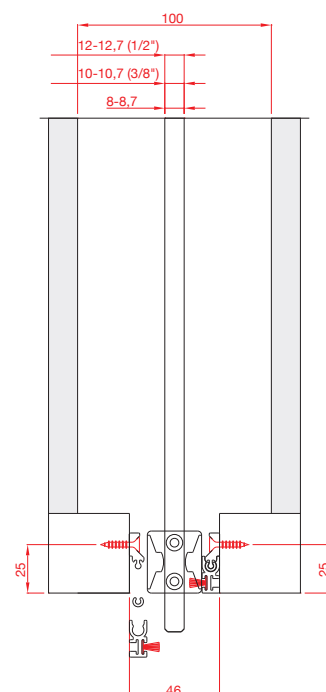
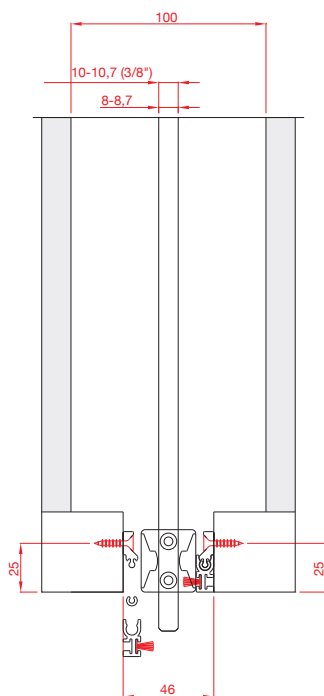
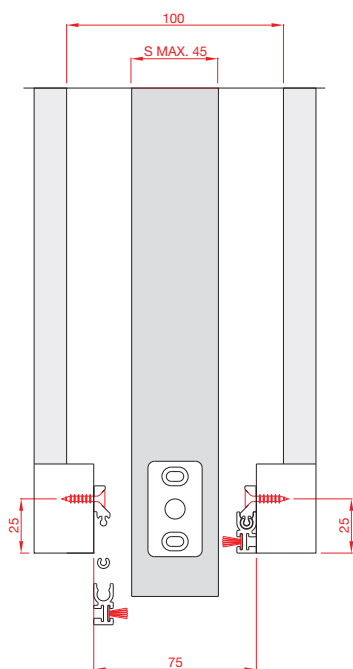
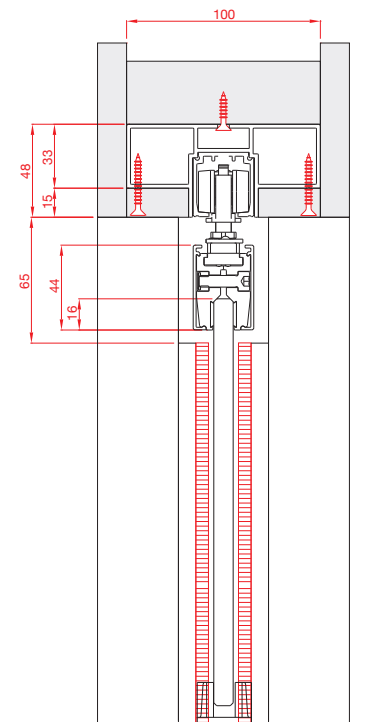
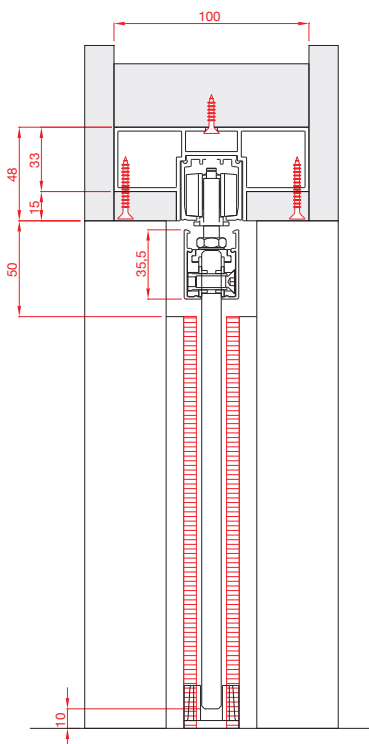
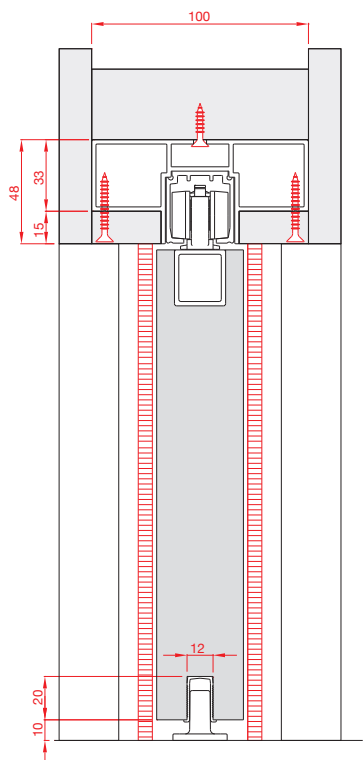

EVOLUTION
(WOOD / LEGNO)

VETRO 40
(GLASS / VETRO)

VETRO 24
(GLASS / VETRO)

ART. 3320 - MEASUREMENTS / MISURE

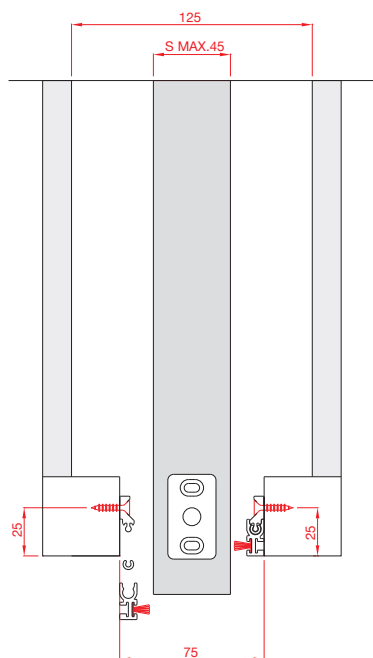
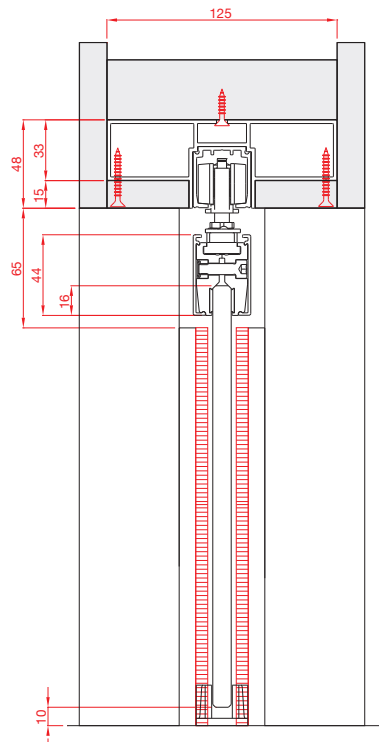
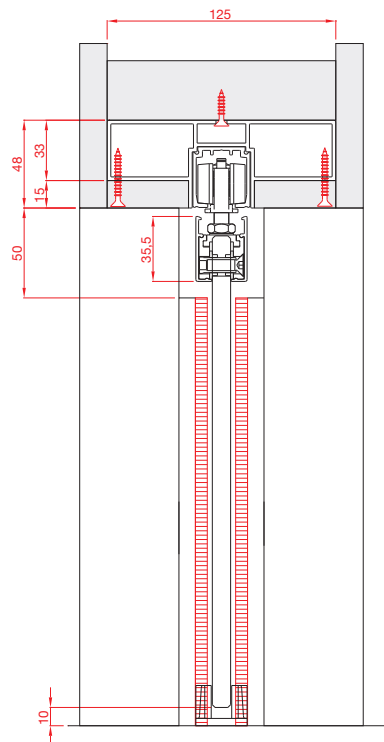
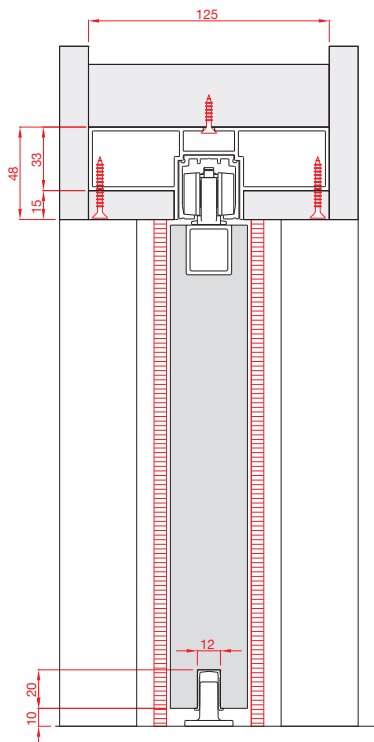

EVOLUTION
(WOOD / LEGNO)

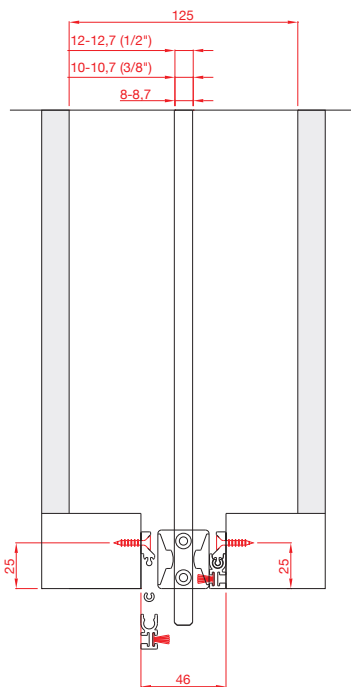

VETRO 40
(GLASS / VETRO)

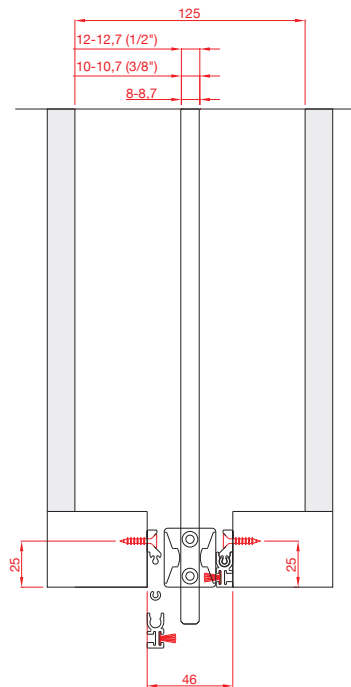

VETRO 24
(GLASS / VETRO)



Classic

Slides with standard bracket
Scorrevoli con staffa normale





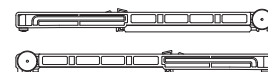
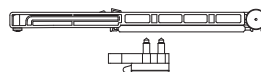























**N.2 STANDARD STOPPERS
N.2 FERMI STANDARD**

**N.1 SOFT DAMPER STOPPER +
N.1 STANDARD STOPPER
N.1 FERMO AMMORTIZZATO +
N.1 FERMO STANDARD**

**N.2 SOFT DAMPER STOPPERS
N.2 FERMI AMMORTIZZATI**

| | | | |
|---|--|---|--|
|  30 kg |   Min. 600 mm PAG. 10 |   Min. 600 mm PAG. 10 |   Min. 600 mm PAG. 10 |
|  40 kg |   Min. 600 mm PAG. 11 | | |
|  50 kg | | | |
|  80 kg |   Min. 600 mm PAG. 14 | | |
|  120 kg | | | |
|  160 kg |   Min. 700 mm PAG. 16 | | |
|  180 kg | | | |
|  240 kg |   Min. 700 mm PAG. 17 | | |
|  250 kg | | | |

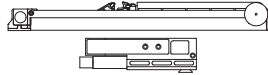
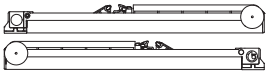

N.2 FLUID DAMPERS
N.2 FERMI AMMORTIZZATI FLUID

N.1 FLUID DAMPER + N.1 SHOCK ABSORBER
N.1 FERMO AMMORTIZZATO FLUID + N.1 FERMO A PINZA AMMORTIZZATO

N.2 SHOCK ABSORBERS
N.2 FERMI A PINZA AMMORTIZZATI

N.2 HYDRAULIC STOPPERS (NAVAL SECTOR)
N.2 FERMI IDRAULICI (SETTORE NAVALE)

| | | | |
|------------------------|------------------------|------------------------|----------------|
| | | | |
| | | | |
| | | | |
| ● | ● | ● | |
| NEW Min. 740 mm | NEW Min. 600 mm | NEW Min. 600 mm | |
| PAG. 12 | PAG. 12 | PAG. 12 | |
| ● | ● | ● | ● |
| NEW Min. 740 mm | NEW Min. 600 mm | NEW Min. 600 mm | Min. 700 mm |
| PAG. 13 | PAG. 13 | PAG. 13 | PAG. 14 |
| ● | ● | ● | |
| NEW Min. 740 mm | NEW Min. 600 mm | NEW Min. 600 mm | |
| PAG. 15 | PAG. 15 | PAG. 15 | |
| | | ● | |
| | | NEW Min. 700 mm | |
| | | PAG. 16 | |
| | | ● | |
| | | NEW Min. 700 mm | |
| | | PAG. 17 | |

Classic

Slides with standard bracket
Scorrevoli con staffa normale

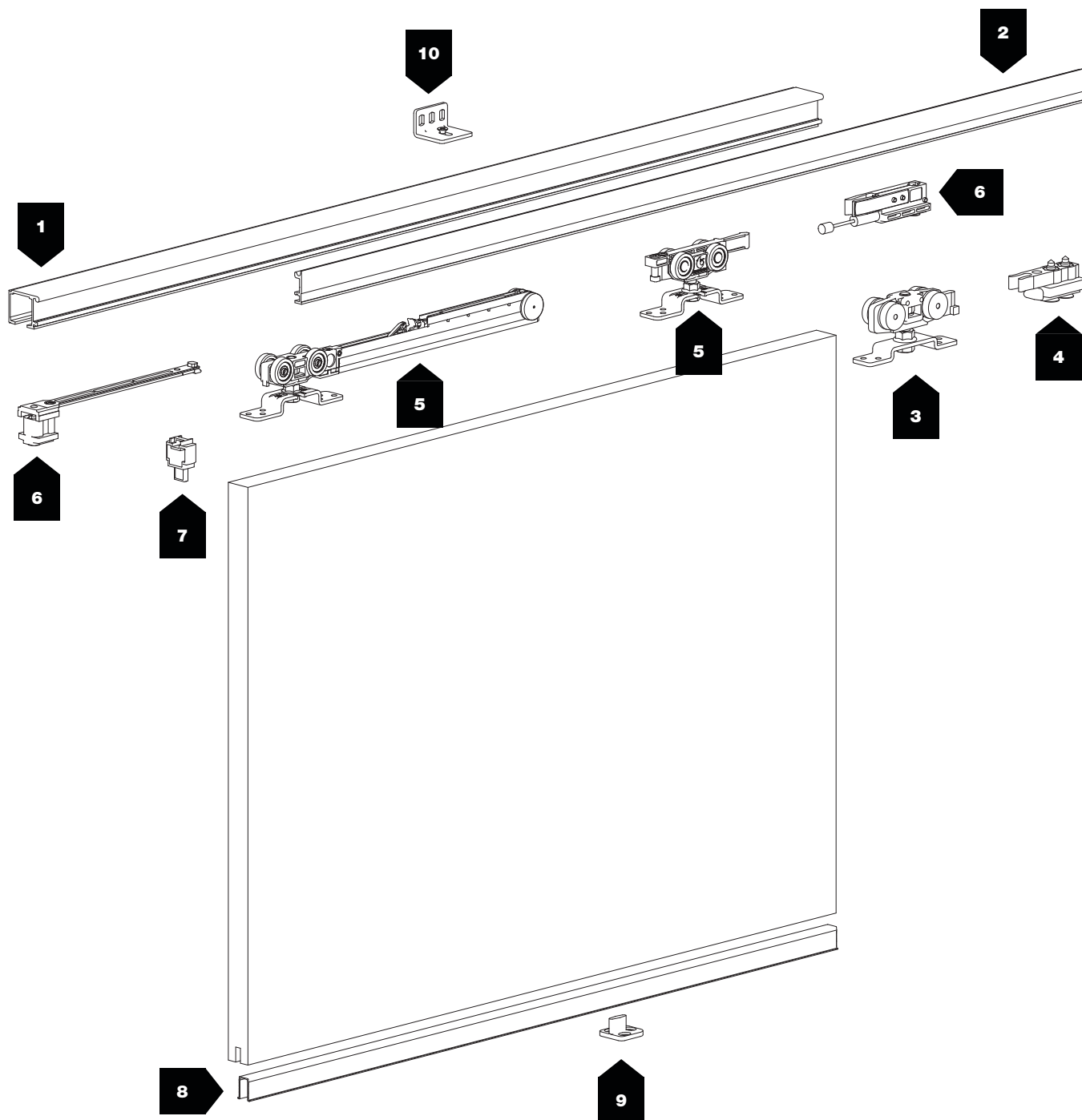

600 ÷ 1500 mm



30 ÷ 250 kg







6 ÷ 15 mm

| N° | Barcode | Image | kg | Category | N° | Barcode | Image | kg | Category | |
|----|--------------------------------------|-------|----|------------|----|--------------------------------------|--------|----|--------------------------|--|
| 1 | 2660 8 00 0.02660 8 01 0.02660 | | - | STANDARD | 1 | 3480 8 00 0.03480 8 01 0.03480 | | - | STANDARD NEW | |
| | 2670 8 00 0.02670 8 01 0.02670 | | - | OPTIONAL + | | 201 8 00 0.00201 8 01 0.00201 | | - | STANDARD | |
| | 1280 8 00 0.01280 8 01 0.01280 | | - | STANDARD | | 234 8 00 0.00234 8 01 0.00234 | | - | OPTIONAL + | |
| | 1080 8 00 0.01080 8 01 0.01080 | | - | OPTIONAL + | | 1710 8 00 0.01710 8 01 0.01710 | | - | OPTIONAL + | |
| | 1359 8 00 0.01359 8 01 0.01359 | | - | OPTIONAL + | | 1720 8 00 0.01720 8 01 0.01720 | | - | OPTIONAL + | |
| | 1559 8 00 0.01559 8 01 0.01559 | | - | OPTIONAL + | | 3490 8 02 0.03490 | | - | OPTIONAL + NEW | |
| | 1700 8 00 0.01700 8 01 0.01700 | | - | OPTIONAL + | | 3491 | | - | OPTIONAL + NEW | |
| | 1160 8 00 0.01160 8 01 0.01160 | | - | STANDARD | | 3 | 2663/T | | 30 | |
| | 160 8 00 0.00160 8 01 0.00160 | | - | OPTIONAL + | | | 41/T | | 40 | |
| | 1660 8 00 0.01660 8 01 0.01660 | | - | OPTIONAL + | | | 81/T | | 80 | |

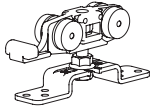
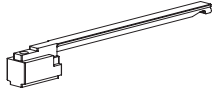
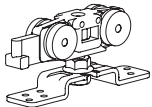
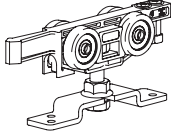
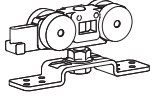
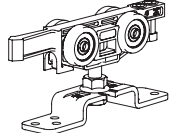
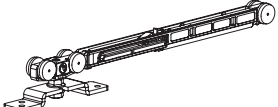
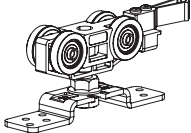
Classic

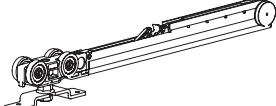
Slides with standard bracket
Scorrevoli con staffa normale

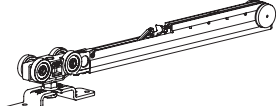
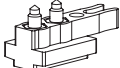
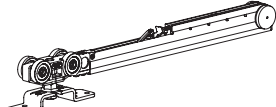
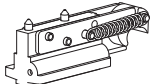
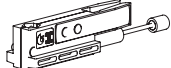
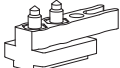
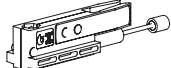
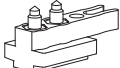
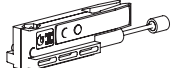
| N° | | | kg | | N° | | | kg | |
|----|---------|---|-----|--|----|----------|---|---------|--------------|
| 3 | 1626/T |  | 80 | | 4 | 2661 |  | 30 | |
| | 1161/T |  | 160 | | | 3358/50 |  | 50 | FLUID NEW |
| | 203/T |  | 240 | | | 3358/120 |  | 80÷120 | FLUID NEW |
| | 2662/T |  | 30 | | | 3488 |  | 180÷250 | FLUID NEW |
| 4 | 2657 |  | 30 | | 5 | 3352/050 |  | 50 | FLUID NEW |
| | 46 |  | 40 | | | 3352/080 |  | 80 | FLUID NEW |
| | 84 |  | 80 | | | 3352/120 |  | 120 | FLUID NEW |
| | 1627/10 |  | 80 | | 6 | 3355/050 |  | 50 | FLUID NEW |
| | 1163 |  | 160 | | | 3355/080 |  | 80 | FLUID NEW |
| | 1165 |  | 240 | | | 3355/120 |  | 120 | FLUID NEW |

| N° | Barcode | Image | kg | FLUID NEW | N° | Barcode | Image | kg | FLUID NEW |
|----|-------------------------------------|-------|---------|---------------|--------|---------|---------|---------|---------------|
| 6 | 3485/180 | | 180 | FLUID NEW | 9 | 93 | | 120 | |
| | 3485/250 | | 250 | FLUID NEW | | 90 | | 30÷120 | OPTIONAL + |
| | 3354 | | 50÷120 | FLUID NEW | | 124 | | 160÷240 | |
| 7 | 3347 | | 50÷120 | | 2855 | | 180÷250 | NEW | |
| 8 | 121 8 23 0.00121 | | 30÷120 | OPTIONAL + | 10 | 409 | | - | |
| | 705 8 23 0.00705 | | 40÷120 | OPTIONAL + | | 126 | | 30 | |
| | 707 8 00 0.00707 8 01 0.00707 | | 40÷120 | OPTIONAL + | | 127/D/V | | 40÷120 | |
| | 760/N 8 14 0.00760 | | 160÷240 | | | 163/DV | | 160÷250 | |
| 9 | 1032 | | 30 | | 163/PV | | 160÷250 | | |
| | 45 | | 40÷80 | | | | | | |

Classic

Slides with standard bracket
Scorrevoli con staffa normale

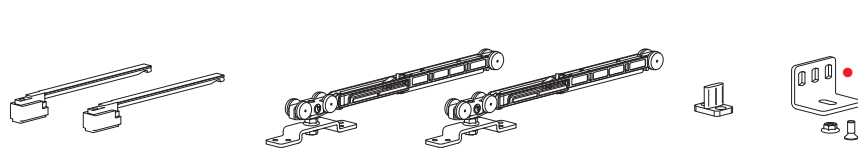

ART. 2660
(8000.02660)
(8010.02660)



30 kg



N.2 Soft damper stoppers
N.2 Fermi ammortizzati



Turned wheels
Ruote tornite

| KIT | ● | N° 3 | OLD CODE | NEW CODE | Min. 600 mm | TRACK-BINARIO | 4x |
|---------|---|------|----------------|----------------|----------------|---------------|----|
| | | | 2662/2662/G/C | K.030.6.1.C | | — | |
| | | — | 2662/2662/G/S | K.030.6.1.S | Min. 600 mm | — | 4x |
| BLISTER | ● | N° 4 | 2662/2662/150C | B.030.6.1.C150 | 700 ÷ 850 mm | 1500 mm | 4x |
| | | N° 5 | 2662/2662/165C | B.030.6.1.C165 | 860 ÷ 950 mm | 1650 mm | 4x |
| | | N° 5 | 2662/2662/200C | B.030.6.1.C200 | 960 ÷ 1100 mm | 2000 mm | 4x |
| | | N° 6 | 2662/2662/250C | B.030.6.1.C250 | 1110 ÷ 1350 mm | 2500 mm | 4x |
| | | N° 7 | 2662/2662/300C | B.030.6.1.C300 | 1360 ÷ 1600 mm | 3000 mm | 4x |
| | | — | 2662/2662/150S | B.030.6.1.S150 | 700 ÷ 850 mm | 1500 mm | 4x |
| | | — | 2662/2662/165S | B.030.6.1.S165 | 860 ÷ 950 mm | 1650 mm | 4x |
| | | — | 2662/2662/200S | B.030.6.1.S200 | 960 ÷ 1100 mm | 2000 mm | 4x |
| | | — | 2662/2662/250S | B.030.6.1.S250 | 1110 ÷ 1350 mm | 2500 mm | 4x |
| | | — | 2662/2662/300S | B.030.6.1.S300 | 1360 ÷ 1600 mm | 3000 mm | 4x |

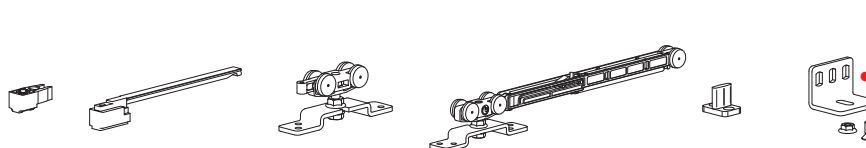

ART. 2660
(8000.02660)
(8010.02660)



30 kg



N.1 Soft damper stopper
N.1 Fermo ammortizzato



N.1 Standard stopper
N.1 Fermo standard



Turned wheels
Ruote tornite

| KIT | ● | N° 3 | OLD CODE | NEW CODE | Min. 600 mm | TRACK-BINARIO | 4x |
|---------|---|------|----------------|----------------|----------------|---------------|----|
| | | | 2662/2663/G/C | K.030.5.1.C | | — | |
| | | — | 2662/2663/G/S | K.030.5.1.S | Min. 600 mm | — | 4x |
| BLISTER | ● | N° 4 | 2662/2663/150C | B.030.5.1.C150 | 700 ÷ 850 mm | 1500 mm | 4x |
| | | N° 5 | 2662/2663/165C | B.030.5.1.C165 | 860 ÷ 950 mm | 1650 mm | 4x |
| | | N° 5 | 2662/2663/200C | B.030.5.1.C200 | 960 ÷ 1100 mm | 2000 mm | 4x |
| | | N° 6 | 2662/2663/250C | B.030.5.1.C250 | 1110 ÷ 1350 mm | 2500 mm | 4x |
| | | N° 7 | 2662/2663/300C | B.030.5.1.C300 | 1360 ÷ 1600 mm | 3000 mm | 4x |
| | | — | 2662/2663/150S | B.030.5.1.S150 | 700 ÷ 850 mm | 1500 mm | 4x |
| | | — | 2662/2663/165S | B.030.5.1.S165 | 860 ÷ 950 mm | 1650 mm | 4x |
| | | — | 2662/2663/200S | B.030.5.1.S200 | 960 ÷ 1100 mm | 2000 mm | 4x |
| | | — | 2662/2663/250S | B.030.5.1.S250 | 1110 ÷ 1350 mm | 2500 mm | 4x |
| | | — | 2662/2663/300S | B.030.5.1.S300 | 1360 ÷ 1600 mm | 3000 mm | 4x |

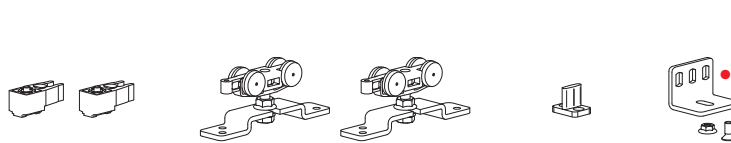

ART. 2660
(8000.02660)
(8010.02660)



30 kg



N.2 Standard stoppers
N.2 Fermi standard



Turned wheels
Ruote tornite

| KIT | ● | N° 3 | OLD CODE | NEW CODE | Min. 600 mm | TRACK-BINARIO | 5x |
|---------|---|------|----------------|----------------|----------------|---------------|----|
| | | | 2663/2663/G/C | K.030.0.1.C | | — | |
| | | — | 2663/2663/G/S | K.030.0.1.S | Min. 600 mm | — | 5x |
| BLISTER | ● | N° 4 | 2663/2663/150C | B.030.0.1.C150 | 700 ÷ 850 mm | 1500 mm | 4x |
| | | N° 5 | 2663/2663/165C | B.030.0.1.C165 | 860 ÷ 950 mm | 1650 mm | 4x |
| | | N° 5 | 2663/2663/200C | B.030.0.1.C200 | 960 ÷ 1100 mm | 2000 mm | 4x |
| | | N° 6 | 2663/2663/250C | B.030.0.1.C250 | 1110 ÷ 1350 mm | 2500 mm | 4x |
| | | N° 7 | 2663/2663/300C | B.030.0.1.C300 | 1360 ÷ 1600 mm | 3000 mm | 4x |
| | | — | 2663/2663/150S | B.030.0.1.S150 | 700 ÷ 850 mm | 1500 mm | 4x |
| | | — | 2663/2663/165S | B.030.0.1.S165 | 860 ÷ 950 mm | 1650 mm | 4x |
| | | — | 2663/2663/200S | B.030.0.1.S200 | 960 ÷ 1100 mm | 2000 mm | 4x |
| | | — | 2663/2663/250S | B.030.0.1.S250 | 1110 ÷ 1350 mm | 2500 mm | 4x |
| | | — | 2663/2663/300S | B.030.0.1.S300 | 1360 ÷ 1600 mm | 3000 mm | 4x |

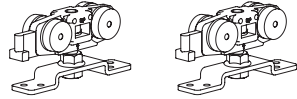
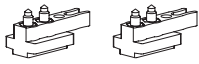

ART. 1280
(8000.01280)
(8010.01280)

| KIT | ● | N° | OLD CODE | NEW CODE | MIN | TRACK-BINARIO | | |
|---------|---|------|-----------------|-----------------|----------------|----------------|---------|----|
| | | | | | | MIN | MIN | |
| KIT | ● | N° 4 | 40/T/G/NOR/CON | K.040.0.1.C | Min. 600 mm | — | 5x | |
| | — | — | 40/T/G/NOR/SEN | K.040.0.1.S | Min. 600 mm | — | 5x | |
| BLISTER | ● | N° 4 | 40/T/P/NR150CON | B.040.0.1.C150 | 700 ÷ 850 mm | 1500 mm | 4x | |
| | | N° 5 | 40/T/P/NR165CON | B.040.0.1.C165 | 860 ÷ 950 mm | 1650 mm | 4x | |
| | | N° 5 | 40/T/P/NR200CON | B.040.0.1.C200 | 960 ÷ 1100 mm | 2000 mm | 4x | |
| | | N° 6 | 40/T/P/NR250CON | B.040.0.1.C250 | 1110 ÷ 1350 mm | 2500 mm | 4x | |
| | | N° 7 | 40/T/P/NR300CON | B.040.0.1.C300 | 1360 ÷ 1600 mm | 3000 mm | 4x | |
| | — | — | — | 40/T/P/NR150SEN | B.040.0.1.S150 | 700 ÷ 850 mm | 1500 mm | 4x |
| | | — | — | 40/T/P/NR165SEN | B.040.0.1.S165 | 860 ÷ 950 mm | 1650 mm | 4x |
| | | — | — | 40/T/P/NR200SEN | B.040.0.1.S200 | 960 ÷ 1100 mm | 2000 mm | 4x |
| | | — | — | 40/T/P/NR250SEN | B.040.0.1.S250 | 1110 ÷ 1350 mm | 2500 mm | 4x |
| | | — | — | 40/T/P/NR300SEN | B.040.0.1.S300 | 1360 ÷ 1600 mm | 3000 mm | 4x |



40 kg



N.2 Standard stoppers
N.2 Fermi standard



Turned wheels
Ruote tornite

Classic

Slides with standard bracket
Scorrevoli con staffa normale

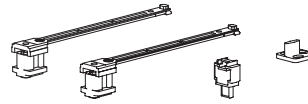
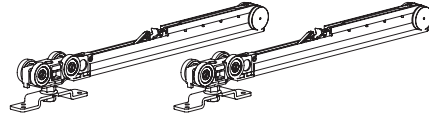

ART. 1280
(8000.01280)
(8010.01280)

FLUID



50 kg



N.2 Fluid dampers
N.2 Fermi ammortizzati
Fluid



Ball bearings
Cuscinetti a sfera

| | | | OLD CODE | NEW CODE | | TRACK-BINARIO | |
|---------|---|------|----------|-----------------------|----------------|-------------------|----|
| KIT | ● | N° 4 | — | K.050.2.1.C | Min. 740 mm | — | 4x |
| | | | — | K.050.2.1.S | Min. 740 mm | — | 4x |
| BLISTER | ● | N° 4 | — | B.050.2.1.C150 | 740 ÷ 850 mm | 1500 mm | 4x |
| | | | — | B.050.2.1.C165 | 860 ÷ 950 mm | 1650 mm | 4x |
| | | | — | B.050.2.1.C200 | 960 ÷ 1100 mm | 2000 mm | 4x |
| | | | — | B.050.2.1.C250 | 1110 ÷ 1350 mm | 2500 mm | 4x |
| | | | — | B.050.2.1.C300 | 1360 ÷ 1600 mm | 3000 mm | 4x |
| | | — | — | B.050.2.1.S150 | 700 ÷ 850 mm | 1500 mm | 4x |
| | | | — | B.050.2.1.S165 | 860 ÷ 950 mm | 1650 mm | 4x |
| | | | — | B.050.2.1.S200 | 960 ÷ 1100 mm | 2000 mm | 4x |
| | | | — | B.050.2.1.S250 | 1110 ÷ 1350 mm | 2500 mm | 4x |
| | | | — | B.050.2.1.S300 | 1360 ÷ 1600 mm | 3000 mm | 4x |

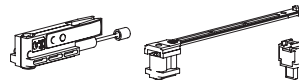
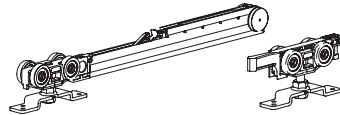

ART. 1280
(8000.01280)
(8010.01280)

FLUID



50 kg



N.1 Fluid damper
N.1 Fermo ammortizzato
Fluid



N.1 Shock absorber
N.1 Fermo a pinza
ammortizzato



Ball bearings
Cuscinetti a sfera

| | | | OLD CODE | NEW CODE | | TRACK-BINARIO | |
|---------|---|------|----------|-----------------------|----------------|-------------------|----|
| KIT | ● | N° 4 | — | K.050.1.1.C | Min. 600 mm | — | 4x |
| | | | — | K.050.1.1.S | Min. 600 mm | — | 4x |
| BLISTER | ● | N° 4 | — | B.050.1.1.C150 | 700 ÷ 850 mm | 1500 mm | 4x |
| | | | — | B.050.1.1.C165 | 860 ÷ 950 mm | 1650 mm | 4x |
| | | | — | B.050.1.1.C200 | 960 ÷ 1100 mm | 2000 mm | 4x |
| | | | — | B.050.1.1.C250 | 1110 ÷ 1350 mm | 2500 mm | 4x |
| | | | — | B.050.1.1.C300 | 1360 ÷ 1600 mm | 3000 mm | 4x |
| | | — | — | B.050.1.1.S150 | 700 ÷ 850 mm | 1500 mm | 4x |
| | | | — | B.050.1.1.S165 | 860 ÷ 950 mm | 1650 mm | 4x |
| | | | — | B.050.1.1.S200 | 960 ÷ 1100 mm | 2000 mm | 4x |
| | | | — | B.050.1.1.S250 | 1110 ÷ 1350 mm | 2500 mm | 4x |
| | | | — | B.050.1.1.S300 | 1360 ÷ 1600 mm | 3000 mm | 4x |

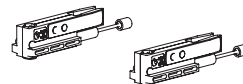
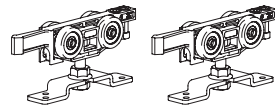

ART. 1280
(8000.01280)
(8010.01280)

FLUID



50 kg



N.2 Shock absorber
N.2 Fermi a pinza
ammortizzati



Ball bearings
Cuscinetti a sfera

| | | | OLD CODE | NEW CODE | | TRACK-BINARIO | |
|---------|---|------|----------|-----------------------|----------------|-------------------|----|
| KIT | ● | N° 4 | — | K.050.3.1.C | Min. 600 mm | — | 5x |
| | | | — | K.050.3.1.S | Min. 600 mm | — | 5x |
| BLISTER | ● | N° 4 | — | B.050.3.1.C150 | 700 ÷ 850 mm | 1500 mm | 4x |
| | | | — | B.050.3.1.C165 | 860 ÷ 950 mm | 1650 mm | 4x |
| | | | — | B.050.3.1.C200 | 960 ÷ 1100 mm | 2000 mm | 4x |
| | | | — | B.050.3.1.C250 | 1110 ÷ 1350 mm | 2500 mm | 4x |
| | | | — | B.050.3.1.C300 | 1360 ÷ 1600 mm | 3000 mm | 4x |
| | | — | — | B.050.3.1.S150 | 700 ÷ 850 mm | 1500 mm | 4x |
| | | | — | B.050.3.1.S165 | 860 ÷ 950 mm | 1650 mm | 4x |
| | | | — | B.050.3.1.S200 | 960 ÷ 1100 mm | 2000 mm | 4x |
| | | | — | B.050.3.1.S250 | 1110 ÷ 1350 mm | 2500 mm | 4x |
| | | | — | B.050.3.1.S300 | 1360 ÷ 1600 mm | 3000 mm | 4x |

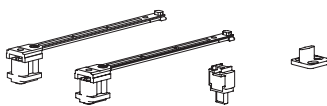
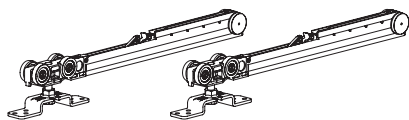

ART. 1280
(8000.01280)
(8010.01280)

| | | OLD CODE | NEW CODE | | TRACK-BINARIO | |
|----------------|---|----------|----------|-----------------------|-------------------|---------|
| KIT | • | N° 5 | — | K.080.2.1.C | Min. 740 mm | — |
| | | — | — | K.080.2.1.S | Min. 740 mm | — |
| BLISTER | • | N° 4 | — | B.080.2.1.C150 | 740 ÷ 850 mm | 1500 mm |
| | | N° 5 | — | B.080.2.1.C165 | 860 ÷ 950 mm | 1650 mm |
| | | N° 5 | — | B.080.2.1.C200 | 960 ÷ 1100 mm | 2000 mm |
| | | N° 6 | — | B.080.2.1.C250 | 1110 ÷ 1350 mm | 2500 mm |
| | | N° 7 | — | B.080.2.1.C300 | 1360 ÷ 1600 mm | 3000 mm |
| | | — | — | B.080.2.1.S150 | 700 ÷ 850 mm | 1500 mm |
| | | — | — | B.080.2.1.S165 | 860 ÷ 950 mm | 1650 mm |
| | | — | — | B.080.2.1.S200 | 960 ÷ 1100 mm | 2000 mm |
| | | — | — | B.080.2.1.S250 | 1110 ÷ 1350 mm | 2500 mm |
| | | — | — | B.080.2.1.S300 | 1360 ÷ 1600 mm | 3000 mm |



80 kg



N.2 Fluid dampers
N.2 Fermi ammortizzati
Fluid



Ball bearings
Cuscinetti a sfera

FLUID

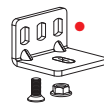
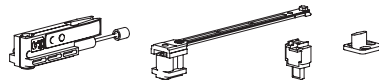
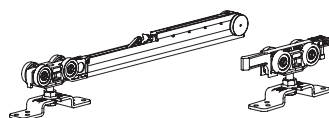

ART. 1280
(8000.01280)
(8010.01280)

| | | OLD CODE | NEW CODE | | TRACK-BINARIO | |
|----------------|---|----------|----------|-----------------------|-------------------|---------|
| KIT | • | N° 5 | — | K.080.1.1.C | Min. 600 mm | — |
| | | — | — | K.080.1.1.S | Min. 600 mm | — |
| BLISTER | • | N° 4 | — | B.080.1.1.C150 | 700 ÷ 850 mm | 1500 mm |
| | | N° 5 | — | B.080.1.1.C165 | 860 ÷ 950 mm | 1650 mm |
| | | N° 5 | — | B.080.1.1.C200 | 960 ÷ 1100 mm | 2000 mm |
| | | N° 6 | — | B.080.1.1.C250 | 1110 ÷ 1350 mm | 2500 mm |
| | | N° 7 | — | B.080.1.1.C300 | 1360 ÷ 1600 mm | 3000 mm |
| | | — | — | B.080.1.1.S150 | 700 ÷ 850 mm | 1500 mm |
| | | — | — | B.080.1.1.S165 | 860 ÷ 950 mm | 1650 mm |
| | | — | — | B.080.1.1.S200 | 960 ÷ 1100 mm | 2000 mm |
| | | — | — | B.080.1.1.S250 | 1110 ÷ 1350 mm | 2500 mm |
| | | — | — | B.080.1.1.S300 | 1360 ÷ 1600 mm | 3000 mm |



80 kg



N.1 Fluid damper
N.1 Fermo ammortizzato
Fluid



N.1 Shock absorber
N.1 Fermo a pinza
ammortizzato



Ball bearings
Cuscinetti a sfera

FLUID

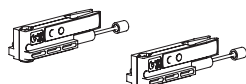
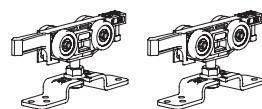

ART. 1280
(8000.01280)
(8010.01280)

| | | OLD CODE | NEW CODE | | TRACK-BINARIO | |
|----------------|---|----------|----------|-----------------------|-------------------|---------|
| KIT | • | N° 5 | — | K.080.3.1.C | Min. 600 mm | — |
| | | — | — | K.080.3.1.S | Min. 600 mm | — |
| BLISTER | • | N° 4 | — | B.080.3.1.C150 | 700 ÷ 850 mm | 1500 mm |
| | | N° 5 | — | B.080.3.1.C165 | 860 ÷ 950 mm | 1650 mm |
| | | N° 5 | — | B.080.3.1.C200 | 960 ÷ 1100 mm | 2000 mm |
| | | N° 6 | — | B.080.3.1.C250 | 1110 ÷ 1350 mm | 2500 mm |
| | | N° 7 | — | B.080.3.1.C300 | 1360 ÷ 1600 mm | 3000 mm |
| | | — | — | B.080.3.1.S150 | 700 ÷ 850 mm | 1500 mm |
| | | — | — | B.080.3.1.S165 | 860 ÷ 950 mm | 1650 mm |
| | | — | — | B.080.3.1.S200 | 960 ÷ 1100 mm | 2000 mm |
| | | — | — | B.080.3.1.S250 | 1110 ÷ 1350 mm | 2500 mm |
| | | — | — | B.080.3.1.S300 | 1360 ÷ 1600 mm | 3000 mm |



80 kg



N.2 Shock absorber
N.2 Fermi a pinza
ammortizzati



Ball bearings
Cuscinetti a sfera

FLUID

Classic

Slides with standard bracket
Scorrevoli con staffa normale

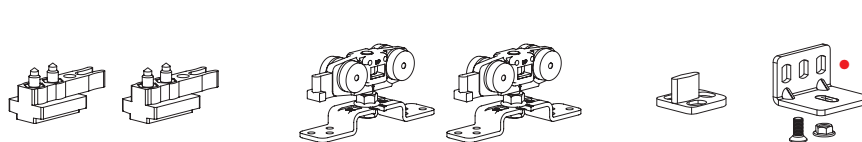

ART. 1280
(8000.01280)
(8010.01280)



80 kg



N.2 Standard stopper
N.2 Fermi standard



Turned wheels
Ruote tornite

| | | | OLD CODE | NEW CODE | | TRACK-BINARIO | |
|----------------|---|------|-----------------|----------------|----------------|-------------------|----|
| KIT | ● | N° 5 | 80/T/G/NOR/CON | K.080.0.1.C | Min. 600 mm | — | 5x |
| | | — | 80/T/G/NOR/SEN | K.080.0.1.S | Min. 600 mm | — | 5x |
| BLISTER | ● | N° 4 | 80/T/P/NR150CON | B.080.0.1.C150 | 700 ÷ 850 mm | 1500 mm | 4x |
| | | N° 5 | 80/T/P/NR165CON | B.080.0.1.C165 | 860 ÷ 950 mm | 1650 mm | 4x |
| | | N° 5 | 80/T/P/NR200CON | B.080.0.1.C200 | 960 ÷ 1100 mm | 2000 mm | 4x |
| | | N° 6 | 80/T/P/NR250CON | B.080.0.1.C250 | 1110 ÷ 1350 mm | 2500 mm | 4x |
| | | N° 7 | 80/T/P/NR300CON | B.080.0.1.C300 | 1360 ÷ 1600 mm | 3000 mm | 4x |
| | | — | 80/T/P/NR150SEN | B.080.0.1.S150 | 700 ÷ 850 mm | 1500 mm | 4x |
| | | — | 80/T/P/NR165SEN | B.080.0.1.S165 | 860 ÷ 950 mm | 1650 mm | 4x |
| | | — | 80/T/P/NR200SEN | B.080.0.1.S200 | 960 ÷ 1100 mm | 2000 mm | 4x |
| | | — | 80/T/P/NR250SEN | B.080.0.1.S250 | 1110 ÷ 1350 mm | 2500 mm | 4x |
| | | — | 80/T/P/NR300SEN | B.080.0.1.S300 | 1360 ÷ 1600 mm | 3000 mm | 4x |

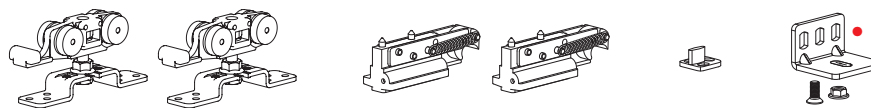

ART. 1280
(8000.01280)
(8010.01280)



80 kg



N.2 Hydraulic stopper
N.2 Fermi idraulici



Suitable for naval sector
Adatto per settore navale



Turned wheels
Ruote tornite

| | | | OLD CODE | NEW CODE | | TRACK-BINARIO | |
|----------------|---|------|----------------|----------------|----------------|-------------------|----|
| KIT | ● | N° 5 | 80/TG/NR/C/FAN | K.080.4.1.C | Min. 700 mm | — | 5x |
| | | — | 80/TG/NR/S/FAN | K.080.4.1.S | Min. 700 mm | — | 5x |
| BLISTER | ● | N° 4 | 80T/PNR150CFAN | B.080.4.1.C150 | 700 ÷ 850 mm | 1500 mm | 4x |
| | | N° 5 | 80T/PNR165CFAN | B.080.4.1.C165 | 860 ÷ 950 mm | 1650 mm | 4x |
| | | N° 5 | 80T/PNR200CFAN | B.080.4.1.C200 | 960 ÷ 1100 mm | 2000 mm | 4x |
| | | N° 6 | 80T/PNR250CFAN | B.080.4.1.C250 | 1110 ÷ 1350 mm | 2500 mm | 4x |
| | | N° 7 | 80T/PNR300CFAN | B.080.4.1.C300 | 1360 ÷ 1600 mm | 3000 mm | 4x |
| | | — | 80T/PNR150SFAN | B.080.4.1.S150 | 700 ÷ 850 mm | 1500 mm | 4x |
| | | — | 80T/PNR165SFAN | B.080.4.1.S165 | 860 ÷ 950 mm | 1650 mm | 4x |
| | | — | 80T/PNR200SFAN | B.080.4.1.S200 | 960 ÷ 1100 mm | 2000 mm | 4x |
| | | — | 80T/PNR250SFAN | B.080.4.1.S250 | 1110 ÷ 1350 mm | 2500 mm | 4x |
| | | — | 80T/PNR300SFAN | B.080.4.1.S300 | 1360 ÷ 1600 mm | 3000 mm | 4x |

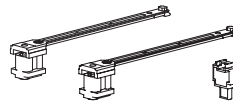
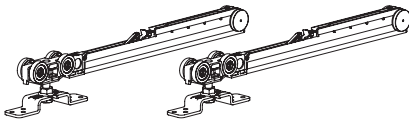

ART. 1280
(8000.01280)
(8010.01280)

| | | OLD CODE | NEW CODE | | TRACK-BINARIO | | |
|----------------|---|----------|----------|----------------|-------------------|---------|----|
| KIT | • | N° 6 | — | K.120.2.1.C | Min. 740 mm | — | 4x |
| | — | — | — | K.120.2.1.S | Min. 740 mm | — | 4x |
| BLISTER | • | N° 4 | — | B.120.2.1.C150 | 740 ÷ 850 mm | 1500 mm | 4x |
| | | N° 5 | — | B.120.2.1.C165 | 860 ÷ 950 mm | 1650 mm | 4x |
| | | N° 5 | — | B.120.2.1.C200 | 960 ÷ 1100 mm | 2000 mm | 4x |
| | | N° 6 | — | B.120.2.1.C250 | 1110 ÷ 1350 mm | 2500 mm | 4x |
| | | N° 7 | — | B.120.2.1.C300 | 1360 ÷ 1600 mm | 3000 mm | 4x |
| | — | — | — | B.120.2.1.S150 | 700 ÷ 850 mm | 1500 mm | 4x |
| | — | — | — | B.120.2.1.S165 | 860 ÷ 950 mm | 1650 mm | 4x |
| | — | — | — | B.120.2.1.S200 | 960 ÷ 1100 mm | 2000 mm | 4x |
| | — | — | — | B.120.2.1.S250 | 1110 ÷ 1350 mm | 2500 mm | 4x |
| | — | — | — | B.120.2.1.S300 | 1360 ÷ 1600 mm | 3000 mm | 4x |



120 kg



N.2 Fluid dampers



N.2 Fermi ammortizzati
Fluid



Ball bearings
Cuscinetti a sfera

FLUID

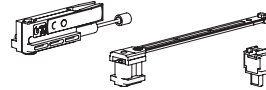
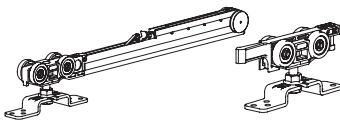

ART. 1280
(8000.01280)
(8010.01280)

| | | OLD CODE | NEW CODE | | TRACK-BINARIO | | |
|----------------|---|----------|----------|----------------|-------------------|---------|----|
| KIT | • | N° 6 | — | K.120.1.1.C | Min. 600 mm | — | 4x |
| | — | — | — | K.120.1.1.S | Min. 600 mm | — | 4x |
| BLISTER | • | N° 4 | — | B.120.1.1.C150 | 700 ÷ 850 mm | 1500 mm | 4x |
| | | N° 5 | — | B.120.1.1.C165 | 860 ÷ 950 mm | 1650 mm | 4x |
| | | N° 5 | — | B.120.1.1.C200 | 960 ÷ 1100 mm | 2000 mm | 4x |
| | | N° 6 | — | B.120.1.1.C250 | 1110 ÷ 1350 mm | 2500 mm | 4x |
| | | N° 7 | — | B.120.1.1.C300 | 1360 ÷ 1600 mm | 3000 mm | 4x |
| | — | — | — | B.120.1.1.S150 | 700 ÷ 850 mm | 1500 mm | 4x |
| | — | — | — | B.120.1.1.S165 | 860 ÷ 950 mm | 1650 mm | 4x |
| | — | — | — | B.120.1.1.S200 | 960 ÷ 1100 mm | 2000 mm | 4x |
| | — | — | — | B.120.1.1.S250 | 1110 ÷ 1350 mm | 2500 mm | 4x |
| | — | — | — | B.120.1.1.S300 | 1360 ÷ 1600 mm | 3000 mm | 4x |



120 kg



N.1 Fluid damper



N.1 Fermo ammortizzato
Fluid



N.1 Shock absorber
N.1 Fermo a pinza
ammortizzato



Ball bearings
Cuscinetti a sfera

FLUID

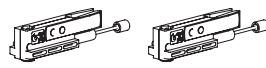
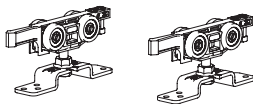

ART. 1280
(8000.01280)
(8010.01280)

| | | OLD CODE | NEW CODE | | TRACK-BINARIO | | |
|----------------|---|----------|----------|----------------|-------------------|---------|----|
| KIT | • | N° 6 | — | K.120.3.1.C | Min. 600 mm | — | 5x |
| | — | — | — | K.120.3.1.S | Min. 600 mm | — | 5x |
| BLISTER | • | N° 4 | — | B.120.3.1.C150 | 700 ÷ 850 mm | 1500 mm | 4x |
| | | N° 5 | — | B.120.3.1.C165 | 860 ÷ 950 mm | 1650 mm | 4x |
| | | N° 5 | — | B.120.3.1.C200 | 960 ÷ 1100 mm | 2000 mm | 4x |
| | | N° 6 | — | B.120.3.1.C250 | 1110 ÷ 1350 mm | 2500 mm | 4x |
| | | N° 7 | — | B.120.3.1.C300 | 1360 ÷ 1600 mm | 3000 mm | 4x |
| | — | — | — | B.120.3.1.S150 | 700 ÷ 850 mm | 1500 mm | 4x |
| | — | — | — | B.120.3.1.S165 | 860 ÷ 950 mm | 1650 mm | 4x |
| | — | — | — | B.120.3.1.S200 | 960 ÷ 1100 mm | 2000 mm | 4x |
| | — | — | — | B.120.3.1.S250 | 1110 ÷ 1350 mm | 2500 mm | 4x |
| | — | — | — | B.120.3.1.S300 | 1360 ÷ 1600 mm | 3000 mm | 4x |



120 kg



N.2 Shock absorber
N.2 Fermi a pinza
ammortizzati



Ball bearings
Cuscinetti a sfera

FLUID

Classic



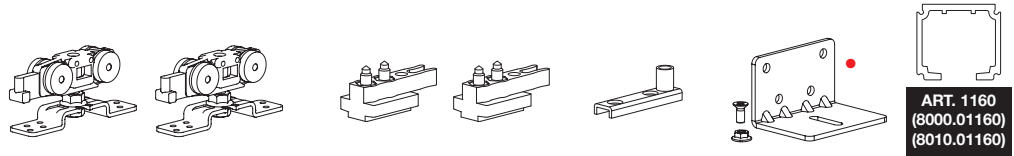

Slides with standard bracket
Scorrevoli con staffa normale



 **160 kg**

 N.2 Standard stoppers
N.2 Fermi standard

 Turned wheels
Ruote tornite



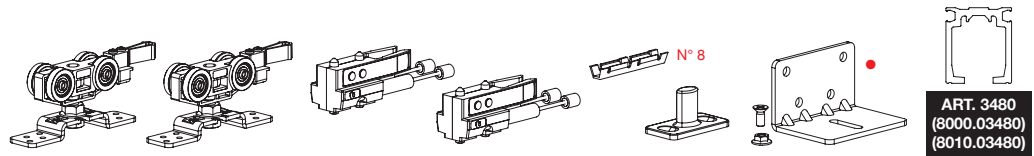

| |  |  | OLD CODE | NEW CODE |  | TRACK-BINARIO  |  |
|----------------|---|---|-----------------|-----------------------|---|--|---|
| KIT | ● | N° 6 | 160/T/G/NOR/CON | K.160.0.1.C | Min. 700 mm | — | 5x |
| | | — | 160/T/G/NOR/SEN | K.160.0.1.S | Min. 700 mm | — | 5x |
| BLISTER | ● | N° 6 | 160/T/P/NR200CO | B.160.0.1.C200 | 960 ÷ 1100 mm | 2000 mm | 4x |
| | | N° 7 | 160/T/P/NR250SE | B.160.0.1.C250 | 1110 ÷ 1350 mm | 2500 mm | 4x |
| | | N° 8 | 160/T/P/NR300CO | B.160.0.1.C300 | 1360 ÷ 1600 mm | 3000 mm | 4x |
| | — | — | 160/T/P/NR200SE | B.160.0.1.S200 | 960 ÷ 1100 mm | 2000 mm | 4x |
| | — | — | 160/T/P/NR250SE | B.160.0.1.S250 | 1110 ÷ 1350 mm | 2500 mm | 4x |
| | — | — | 160/T/P/NR300SE | B.160.0.1.S300 | 1360 ÷ 1600 mm | 3000 mm | 4x |



 **180 kg**

 N.2 Shock absorber
N.2 Fermi a pinza
ammortizzati

 Ball bearings
Cuscinetti a sfera

| |  |  | OLD CODE | NEW CODE |  | TRACK-BINARIO  |  |
|----------------|---|---|-----------------|-----------------------|---|--|---|
| KIT | ● | N° 6 | — | K.180.3.1.C | Min. 700 mm | — | 5x |
| | | — | — | K.180.3.1.S | Min. 700 mm | — | 5x |
| BLISTER | ● | N° 6 | — | B.180.3.1.C200 | 960 ÷ 1100 mm | 2000 mm | 4x |
| | | N° 7 | — | B.180.3.1.C250 | 1110 ÷ 1350 mm | 2500 mm | 4x |
| | | N° 8 | — | B.180.3.1.C300 | 1360 ÷ 1600 mm | 3000 mm | 4x |
| | — | — | 160/T/P/NR200SE | B.180.3.1.S200 | 960 ÷ 1100 mm | 2000 mm | 4x |
| | — | — | 160/T/P/NR250SE | B.180.3.1.S250 | 1110 ÷ 1350 mm | 2500 mm | 4x |
| | — | — | 160/T/P/NR300SE | B.180.3.1.S300 | 1360 ÷ 1600 mm | 3000 mm | 4x |

FLUID

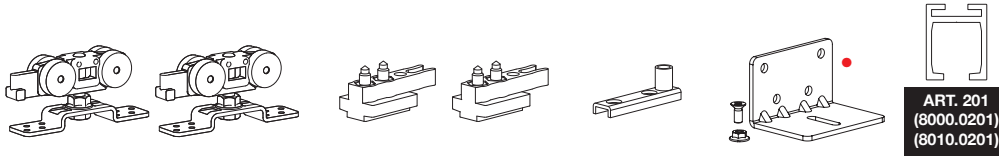

| | | | OLD CODE | NEW CODE | | TRACK-BINARIO | |
|----------------|---|------|-----------------|-----------------------|----------------|-------------------|----|
| KIT | ● | N° 7 | 240/T/G/NOR/CON | K.240.0.1.C | Min. 700 mm | — | 5x |
| | | — | 240/T/G/NOR/SEN | K.240.0.1.S | Min. 700 mm | — | 5x |
| BLISTER | ● | N° 6 | 240/T/P/NR200CO | B.240.0.1.C200 | 960 ÷ 1100 mm | 2000 mm | 4x |
| | | N° 7 | 240/T/P/NR250CO | B.240.0.1.C250 | 1110 ÷ 1350 mm | 2500 mm | 4x |
| | | N° 8 | 240/T/P/NR300CO | B.240.0.1.C300 | 1360 ÷ 1600 mm | 3000 mm | 4x |
| | | — | 240/T/P/NR200SE | B.240.0.1.S200 | 960 ÷ 1100 mm | 2000 mm | 4x |
| | | — | 240/T/P/NR250SE | B.240.0.1.S250 | 1110 ÷ 1350 mm | 2500 mm | 4x |
| | | — | 240/T/P/NR300SE | B.240.0.1.S300 | 1360 ÷ 1600 mm | 3000 mm | 4x |



240 kg



N.2 Standard stoppers
N.2 Fermi standard



Turned wheels
Ruote tornite

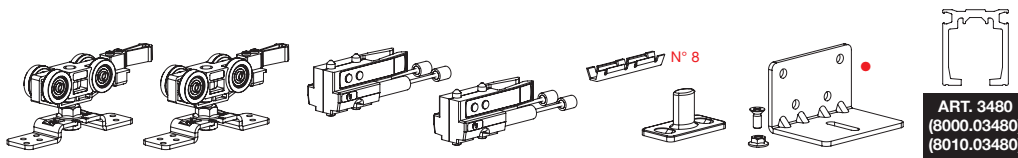

| | | | OLD CODE | NEW CODE | | TRACK-BINARIO | |
|----------------|---|------|----------|-----------------------|----------------|-------------------|----|
| KIT | ● | N° 7 | — | K.250.3.1.C | Min. 700 mm | — | 5x |
| | | — | — | K.250.3.1.S | Min. 700 mm | — | 5x |
| BLISTER | ● | N° 6 | — | B.250.3.1.C200 | 960 ÷ 1100 mm | 2000 mm | 4x |
| | | N° 7 | — | B.250.3.1.C250 | 1110 ÷ 1350 mm | 2500 mm | 4x |
| | | N° 8 | — | B.250.3.1.C300 | 1360 ÷ 1600 mm | 3000 mm | 4x |
| | | — | — | B.250.3.1.S200 | 960 ÷ 1100 mm | 2000 mm | 4x |
| | | — | — | B.250.3.1.S250 | 1110 ÷ 1350 mm | 2500 mm | 4x |
| | | — | — | B.250.3.1.S300 | 1360 ÷ 1600 mm | 3000 mm | 4x |



250 kg



N.2 Shock absorber
N.2 Fermi a pinza
ammortizzati



Ball bearings
Cuscinetti a sfera

N.2 Soft damper stoppers
N.2 Fermi ammortizzati



N.1 Soft damper stopper + N.1 Standard stopper
N.1 Fermo ammortizzato + N.1 Fermo standard

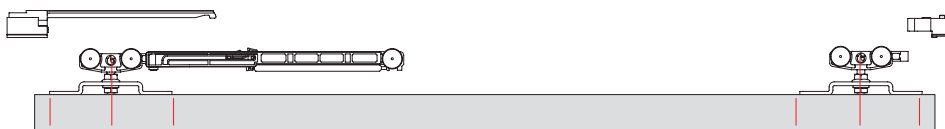

N.2 Standard stoppers
N.2 Fermi standard

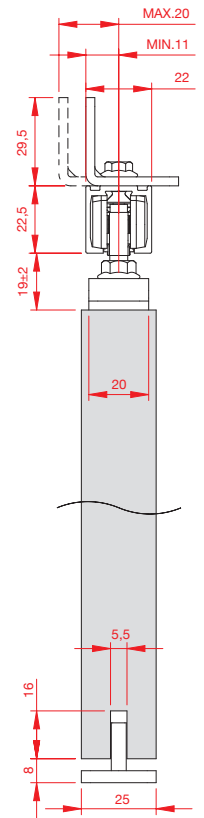
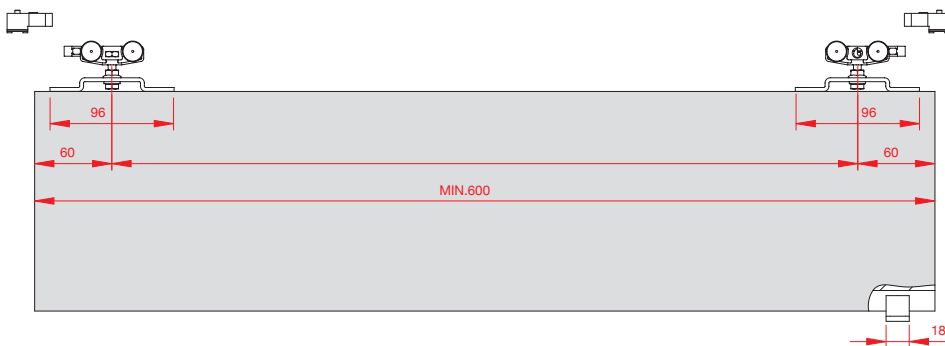

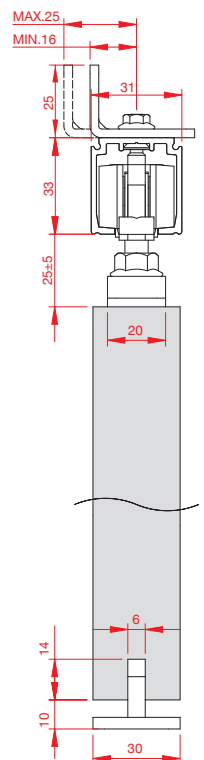
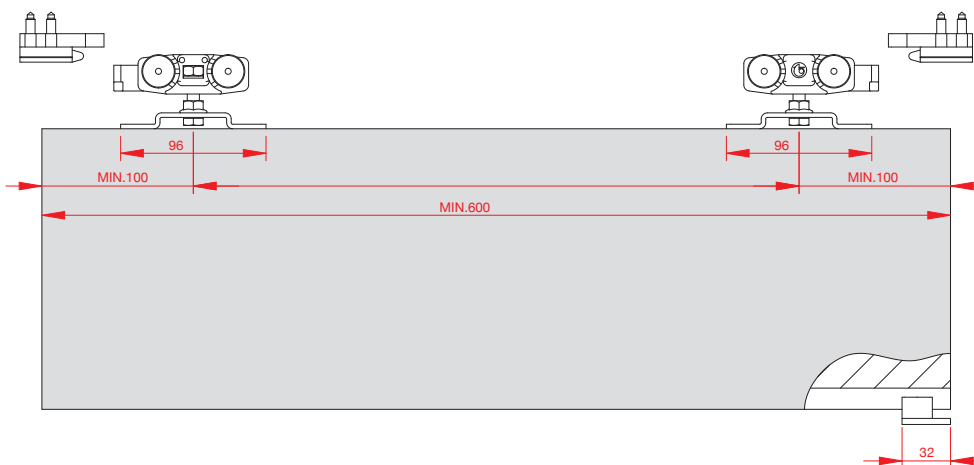

30 kg

N.2 Standard stoppers
N.2 Fermi standard



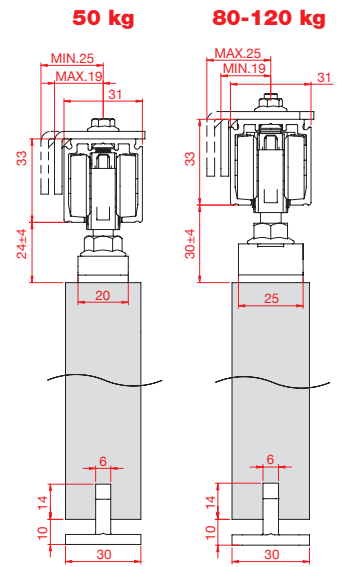
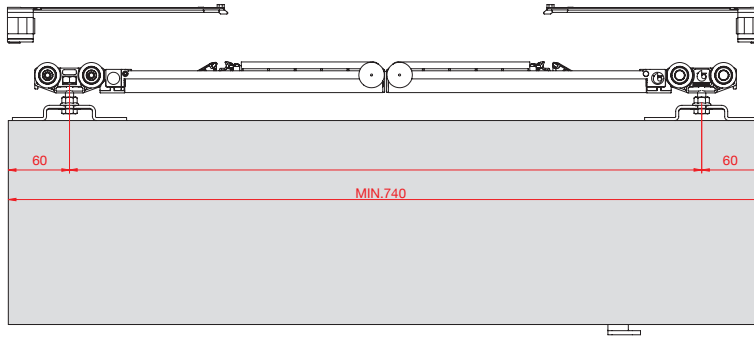

40 kg

N.2 Fluid dampers
N.2 Fermi ammortizzati Fluid

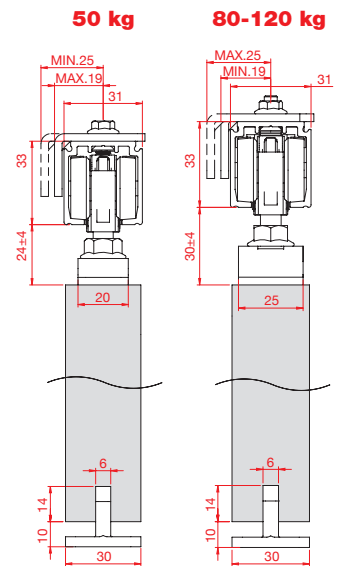
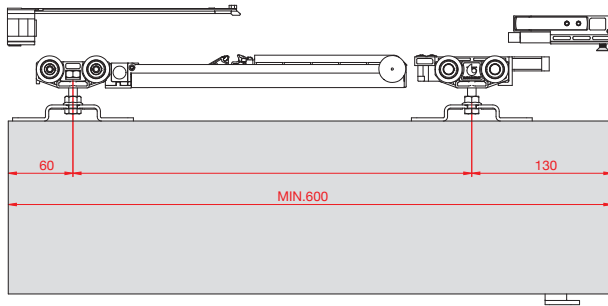

N.1 Fluid damper + N.1 Shock absorber
N.1 Fermo ammortizzato Fluid + N.1 Fermo a pinza ammortizzato



50 kg
80 kg
120 kg

FLUID

N.2 Shock absorber
N.2 Fermi a pinza ammortizzati

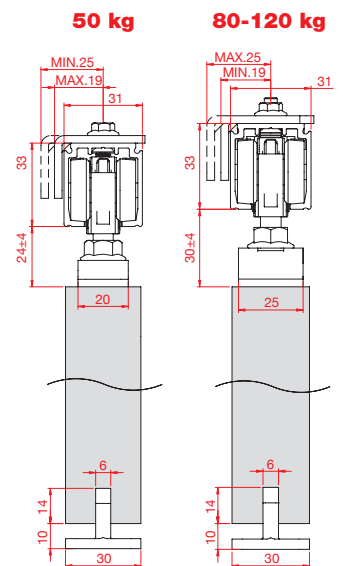
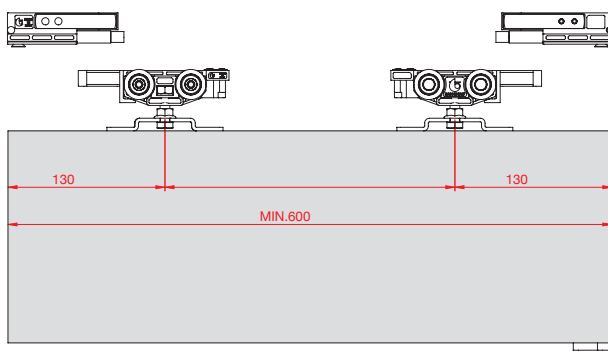

N.2 Standard stoppers
N.2 Fermi standard

80 kg

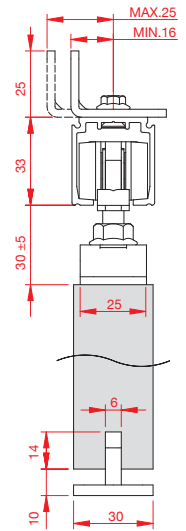
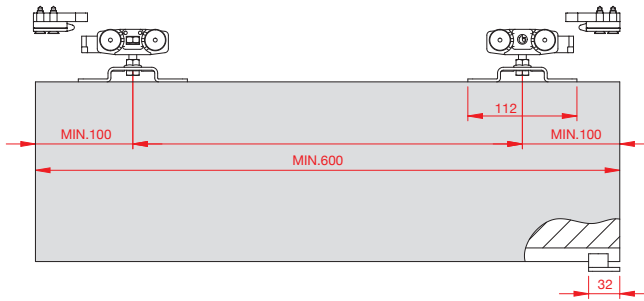

N.2 Hydraulic stopper
N.2 Fermi idraulici

80 kg

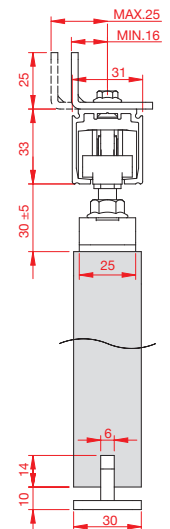
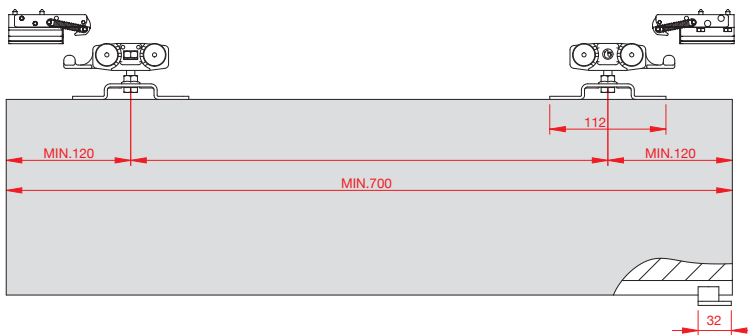
N.2 Standard stopper
N.2 Fermi standard

160 kg

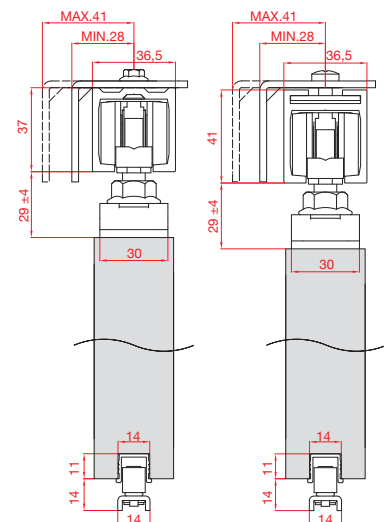
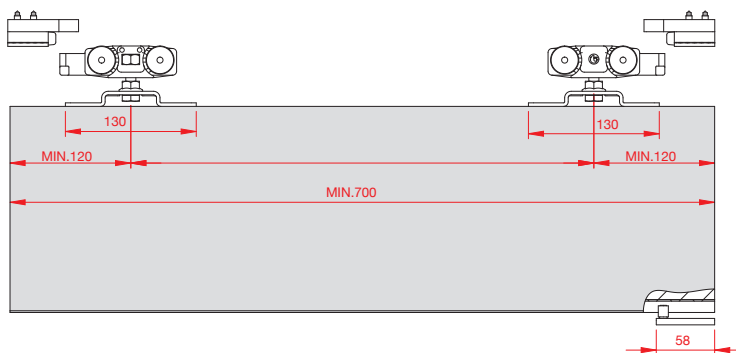

N.2 Shock absorber
N.2 Fermi a pinza ammortizzati

180 kg

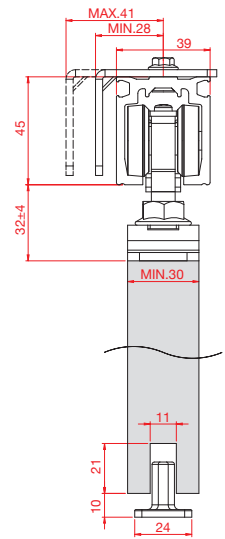
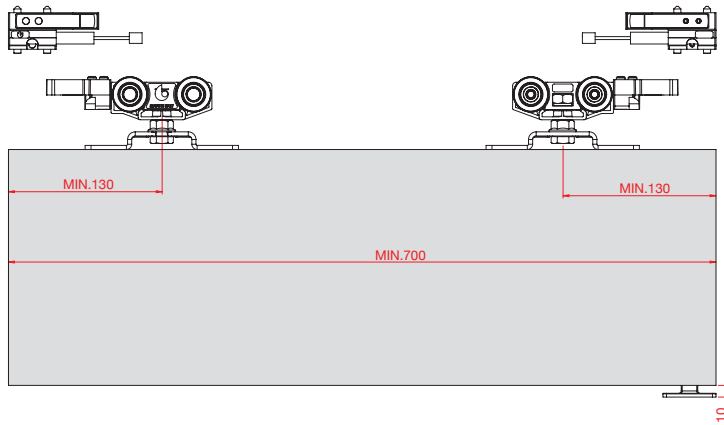

N.2 Standard stopper
N.2 Fermi standard

240 kg

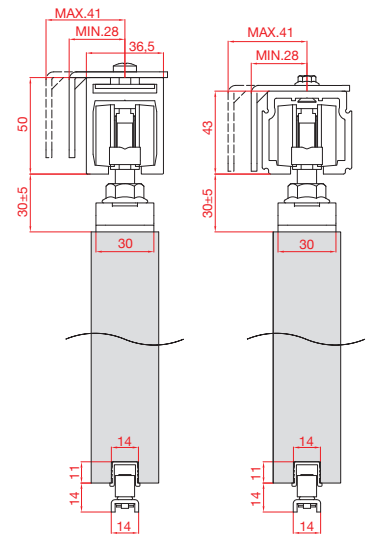
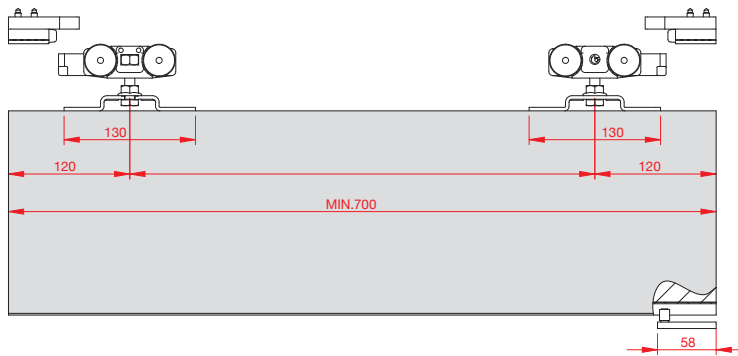

N.2 Shock absorber
N.2 Fermi a pinza ammortizzati

250 kg

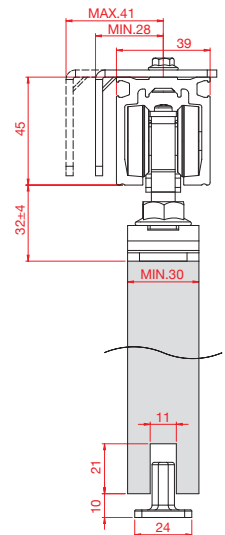
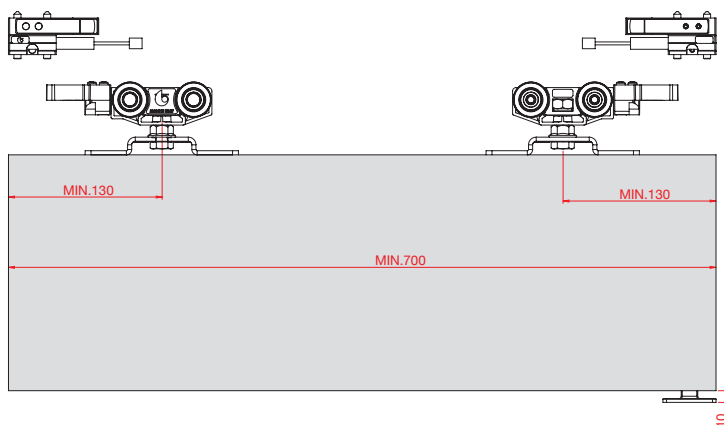



Clear

Sliding systems for shower box
Sistemi scorrevoli per box doccia





Clear is a sliding system **designed specifically for shower box, extremely resistant** thanks to stainless steel inox bearings.

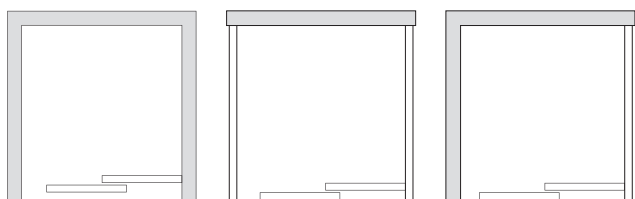

Clear is a **very flexible system**, since it allows the installation in the wall-wall configuration, in the glass-glass configuration or in the wall-glass configuration.





Clear è il sistema scorrevole **studiato appositamente per i box doccia**, estremamente **resistente** grazie ai cuscinetti realizzati in acciaio inox.

Clear è un sistema **altamente versatile e flessibile**, poiché permette l'installazione con posa in nicchia (nella configurazione parete-parete), con posa in luce (nella configurazione vetro-vetro) o ad angolo (nella configurazione parete-vetro).





| Clear | | COMPLETE BOX KIT / KIT COMPLETO IN SCATOLA | |  |
|--------------|-----------------------------|--|--|---|
| K | Complete kit / Kit completo | | | |
| | | 0411 |  Clear | |
| | | | | |
| | | 4 |  8-8,7 - 10-10,7 mm | |
| | | | | |
| | | | | 07 Anodized Brill / Brill |

| Clear | | COMPLETE BOX KIT / KIT COMPLETO IN SCATOLA | |  |
|--------------|-------------------------------------|--|--|---|
| B | Complete blister / Blister completo | | | |
| | | 0412 | Track / Binario - 2000 mm | |
| | | 0413 | Track / Binario - 3000 mm | |
| | | | | |
| | | 0 |  40 kg | |
| | | | | |
| | | | | 07 Anodized Brill / Brill |

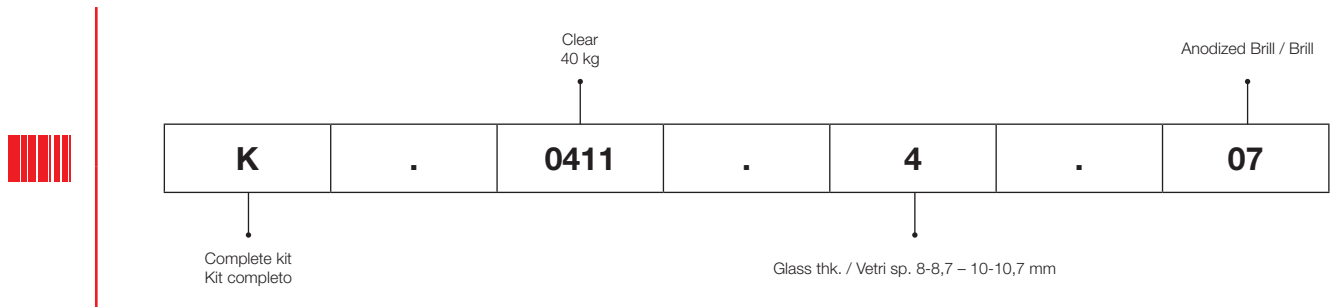
EXAMPLE / ESEMPIO



| Tracks / Binari | | ALUMINUM FINISHES CODES / CODICI FINITURE ALLUMINIO | |  |
|------------------------|---|---|------------------------|---|
| CODE / CODICE | FINISH COLOR / COLORE FINITURA | | | |
| 8 07 0.0 |  | 07 BRILL | Anodized Brill / Brill | STANDARD |

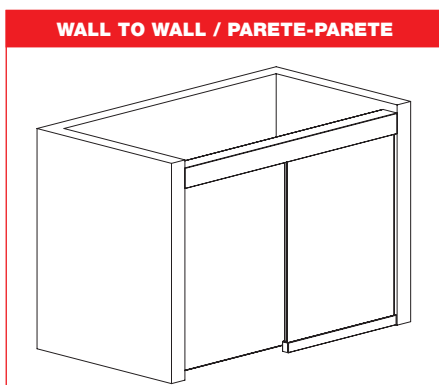
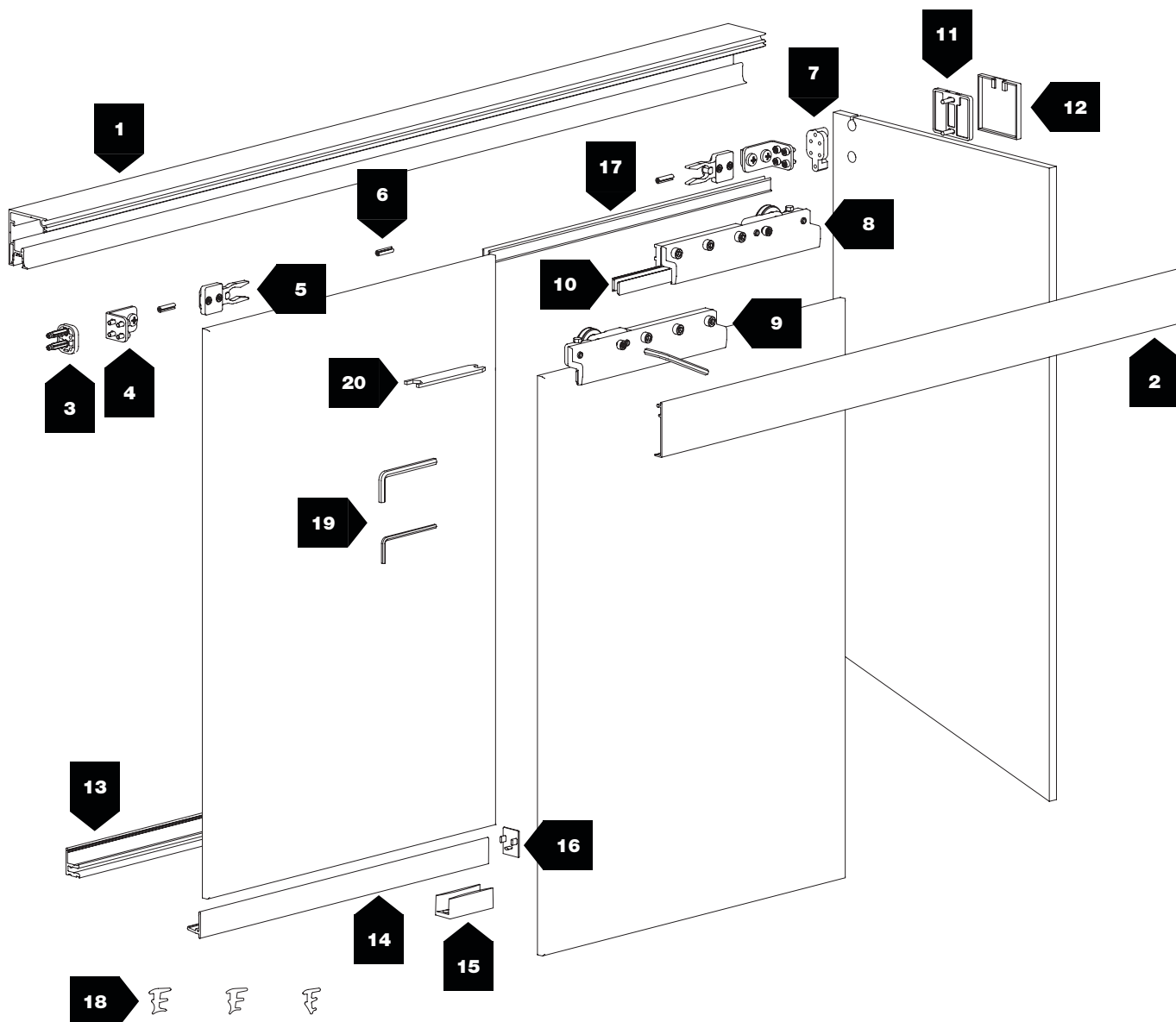

8-8,7 ÷ 10-10,7 mm



40 kg



1000 mm

| N° | Barcode | Image | kg | | N° | Barcode | Image | kg | |
|----|----------------------|-------|----|---|----|----------------------|-------|----|---|
| 1 | 3250 8 07 0.03250 | | — | | 13 | 1774 8 07 2.01774 | | — | |
| 2 | 3260 8 07 0.03260 | | — | | 14 | 1776 8 07 0.01776 | | — | |
| 3 | 3258 | | 40 | | 15 | 1367/TR | | 40 | Glass thk. Vetri sp. 8-8,7 mm (5/16") |
| 4 | 3253 | | 40 | | 15 | 1366/TR | | 40 | Glass thk. Vetri sp. 10-10,7 mm (3/8") |
| 5 | 3252 | | 40 | | 16 | 1784 | | — | |
| 6 | 1222 | | — | | 17 | 2630 8 07 0.02630 | | — | |
| 7 | 3257 | | — | | 18 | 328 | | — | Glass thk. Vetri sp. 8-8,7 mm (5/16") |
| 8 | 3251/DX | | 40 | | 18 | 326 | | — | Glass thk. Vetri sp. 10-10,7 mm (3/8") |
| 9 | 3251/SX | | 40 | | 18 | 324 | | — | Glass thk. Vetri sp. 8-8,7 mm - 10-10,7 mm (5/16" - 3/8") |
| 10 | 1707 | | — | Glass thk. Vetri sp. 8-8,7 mm (5/16") | 19 | 538 | | — | |
| | 1704 | | — | Glass thk. Vetri sp. 10-10,7 mm (3/8") | | 539 | | — | |
| 11 | 3256 | | — | | 20 | 1029 | | — | |
| 12 | 3254/BRI | | — | | | | | | |

 **40 kg**

 Max 1000 mm

.07 Anodized Brill Brill

**WALL TO GLASS
PARETE-VERRO**

**WALL TO WALL
PARETE-PARETE**

**GLASS TO GLASS
VETRO-VETRO**

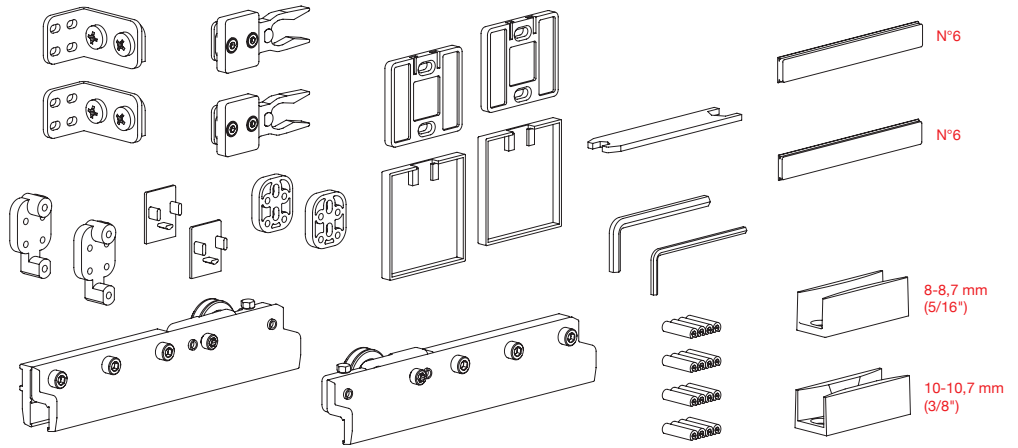



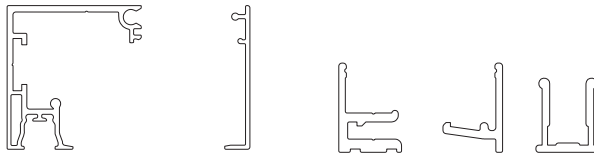

|  | OLD CODE | NEW CODE |  |  |  |
|---|-----------|-------------|---|---|---|
| KIT | 3251/3257 | K.0411.4.07 | 40 kg | 8-8,7 (5/16") - 10-10,7 (3/8") mm | 4x |

 **40 kg**

.07 Anodized Brill Brill



|  | OLD CODE | NEW CODE |  | TRACK-BINARIO  |  |
|--|----------|-------------|--|--|--|
| BLISTER | - | B.0412.0.07 | 40 kg | 2000 mm | 4x |
| | - | B.0413.0.07 | | 3000 mm | 4x |

MEASUREMENTS DESCRIPTION / DESCRIZIONI MISURE

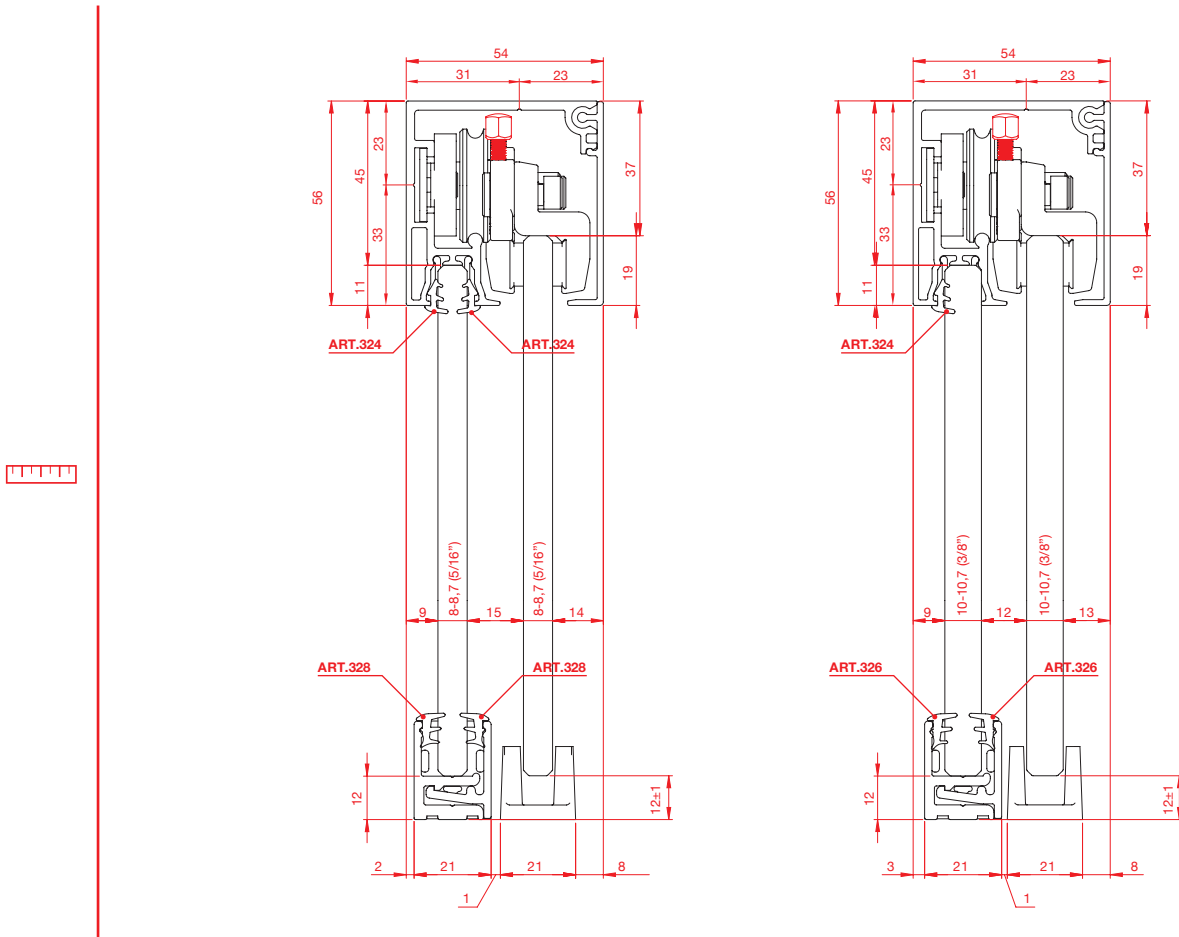



Diva Air

Patented sliding system with exposed aluminium track and soft-closing
Sistema di scorrevoli brevettato per porte con fermo ammortizzato

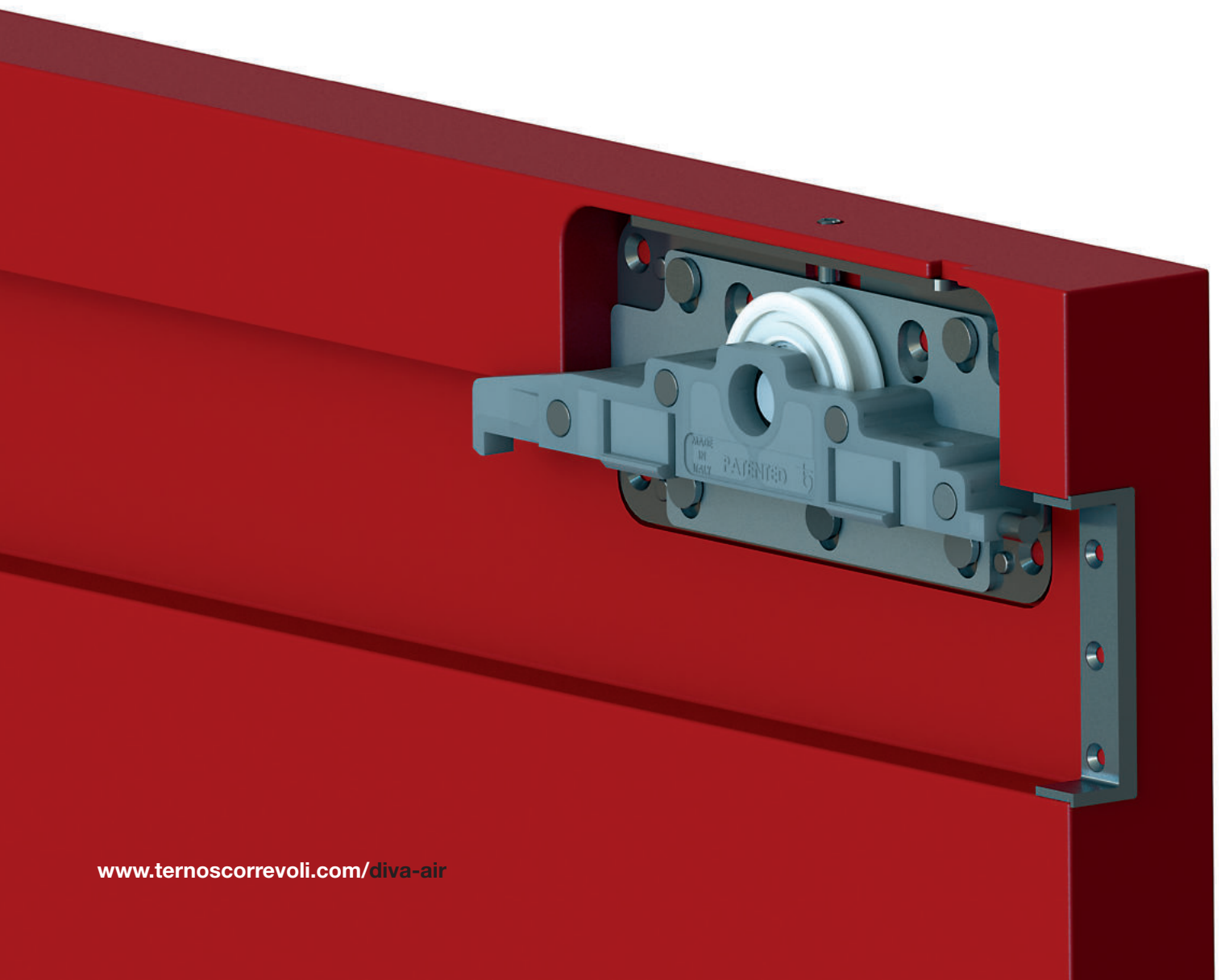



Diva Air

Sliding system with amortised stopper
Scorrevoli per porte con fermo ammortizzato

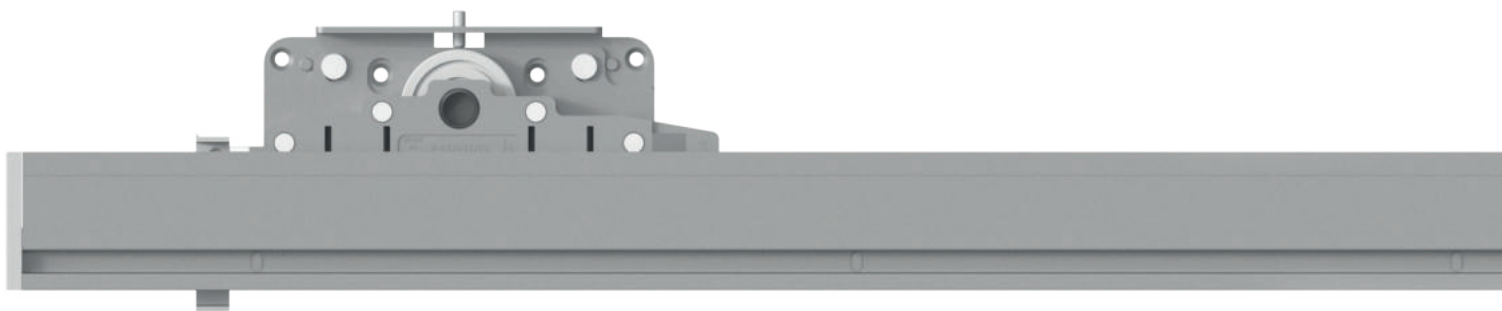

PATENTED

Easy mounting

The air damper is integrated into the track and is equipped with an automatic loading system; the pre-loading operation must be made before the first usage of the door.

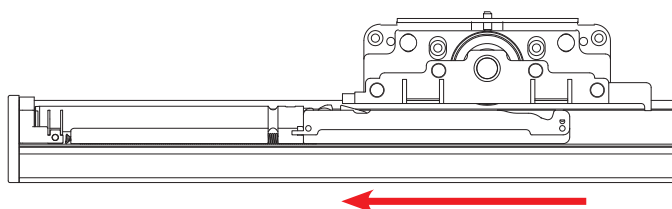





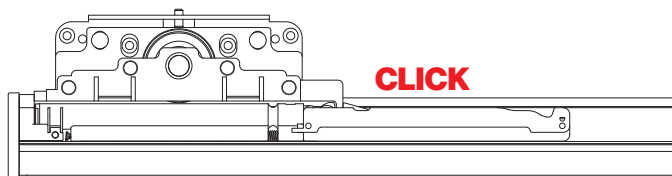

Facile da montare

L'ammortizzatore è inserito nel binario ed è dotato di caricamento automatico, da eseguire prima dell'utilizzo della porta.



Diva Air COMPLETE BOX KIT / KIT COMPLETO IN SCATOLA 

| | | | |
|---|---|--|--|
| K Complete Diva Air kit for N°1 wooden door / Kit completo Diva Air per N°1 porta in legno | | | |
| 0051 |  | Wall distance 12 mm Distanza dal muro 12 mm | |
| 0052 |  | Wall distance 12 mm Distanza dal muro 12 mm | |
| 0053 |  | Wall distance 18 mm Distanza dal muro 18 mm | |
| 0054 |  | Wall distance 18 mm Distanza dal muro 18 mm | |
| . | | | |
| | 1 | N.2 Standard stoppers N.2 Fermi standard |  |
| | 2 | N.2 Soft damper stoppers N.2 Fermi ammortizzati |  |
| . | | | |
| | 01 | Anodized Silver / Argento | |
| | 14 | Anodized Black / Nero | |
| | 16 | Anodized Nickel / Nichel | |
| | 26 | Anodized Graphite / Grafite | |

EXAMPLE / ESEMPIO

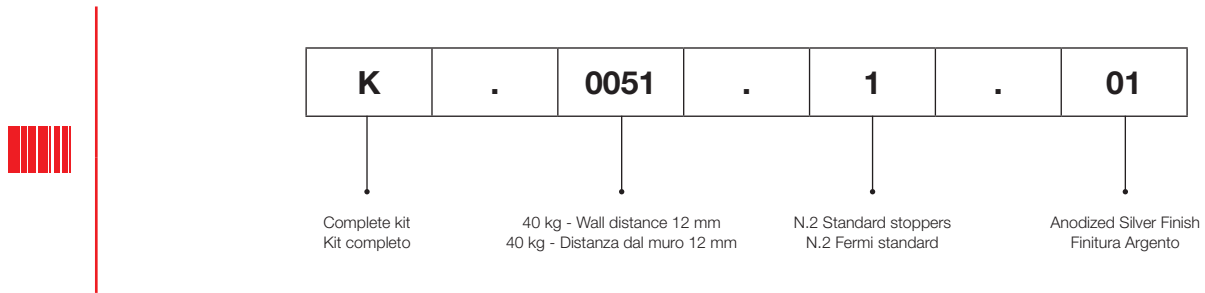

Tracks / Binari ALUMINUM FINISHES CODES / CODICI FINITURE ALLUMINIO 



| CODE / CODICE | FINISH COLOR / COLORE FINITURA | | | |
|----------------|---|----------------|--|-----------------|
| 8 00 0.0 |  | 00 G | Raw / Mill Finish / Neutro / Grezzo | STANDARD |
| 8 01 0.0 |  | 01 A | Anodized Silver / Argento | |
| 8 02 0.0 |  | 02 AS | Brushed Anodized Silver / Argento Spazzolato | |
| 8 14 0.0 |  | 14 N | Anodized Black / Nero | SPECIAL |
| 8 15 0.0 |  | 15 NS | Brushed Anodized Black / Nero Spazzolato | |
| 8 16 0.0 |  | 16 NK | Anodized Nickel / Nichel | |
| 8 17 0.0 |  | 17 NKS | Brushed Anodized Nickel / Nichel Spazzolato | |
| 8 25 0.0 |  | 25 GRFS | Brushed Anodized Graphite / Grafite Spazzolato | |
| 8 26 0.0 |  | 26 GRF | Anodized Graphite / Grafite | |

Tracks / Binari PLASTIC FINISHES CODES / CODICI FINITURE PLASTICA 

| CODE / CODICE | FINISH COLOR / COLORE FINITURA | | | |
|----------------|---|--------------|---------------|-----------------|
| 8 23 0.0 |  | 23 GR | Gray / Grigio | STANDARD |

Diva Air

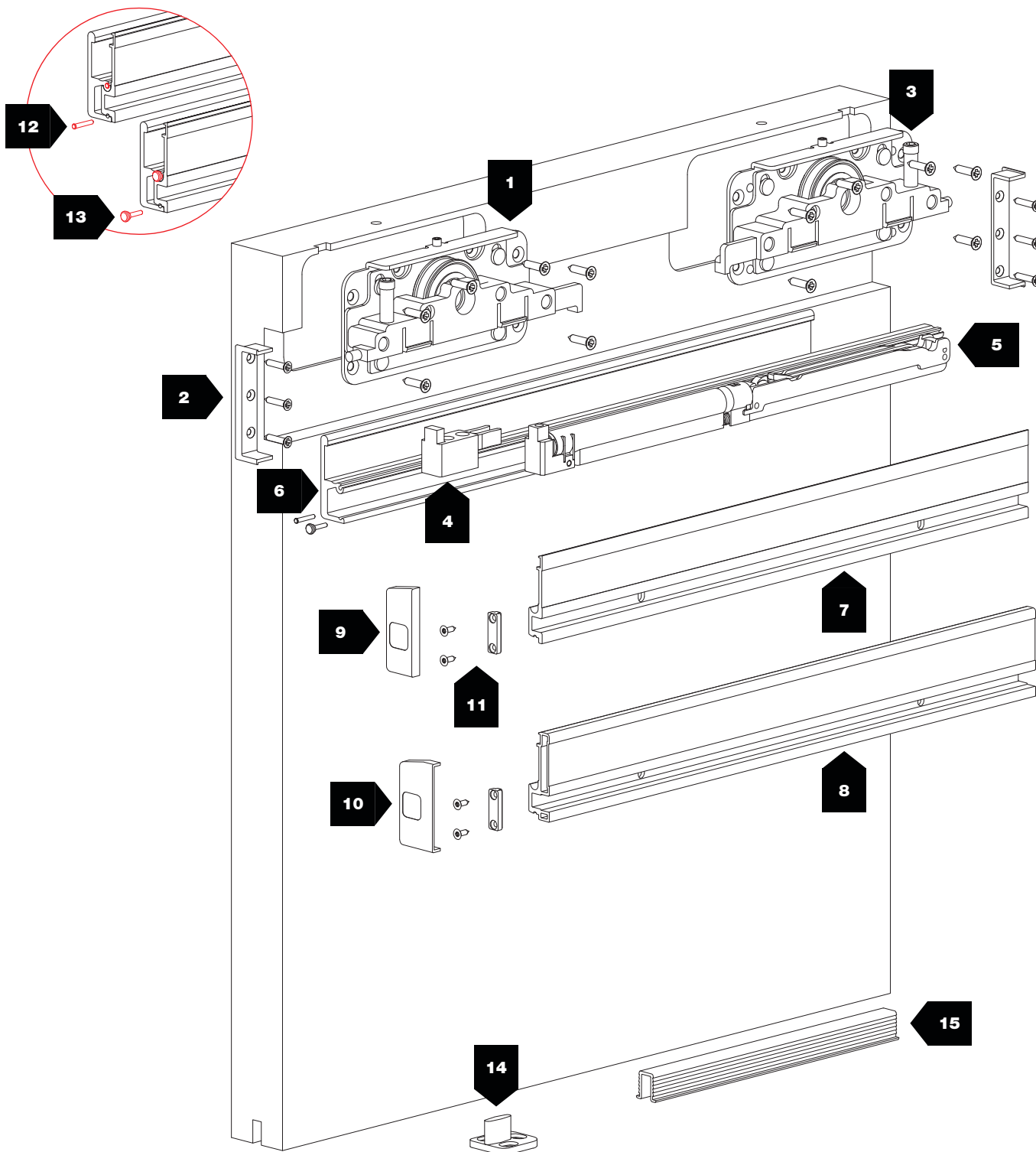
Sliding system with amortised stopper
Scorrevoli per porte con fermo ammortizzato

12 - 18 mm



40 - 80 kg



10 mm











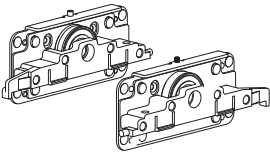

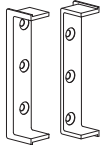
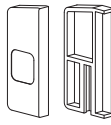
COLORS / COLORI

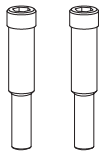
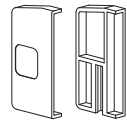
 Anodized Silver
Argento

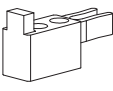
 Anodized Black
Nero

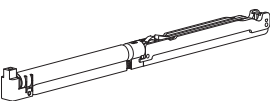

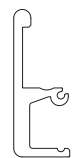
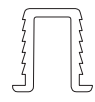
 Anodized Nickel
Nichel

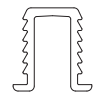
 Anodized Graphite
Grafite

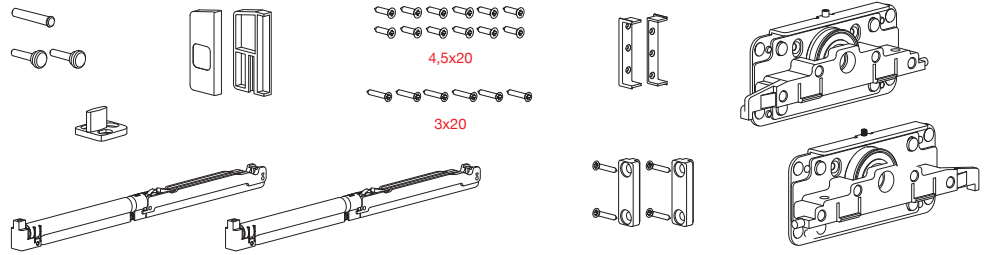
| N° | | | kg | | N° | | | kg | |
|----|----------------------|---|-------|--|----|-------------------------------------|---|----|--|
| 1 | 1478 |  | 40±80 | | 8 | 1490 8 01 2.01490 |  | — | |
| 2 | 1369 |  | — | | 9 | 1474 |  | — |  12 mm |
| 3 | 1479 |  | — | | 10 | 1475 |  | — |  18 mm |
| 4 | 1473 |  | 40 | | 11 | 1472 |  | — | |
| | 1477 | | 80 | | 12 | 1337 |  | — | |
| 5 | 1476/35G |  | 40 | | 13 | 1333 |  | — | |
| | 1476/80Y | | 80 | | 14 | 45 |  | — | |
| 6 | 1470 8 02 0.01470 |  | — | | 15 | 707 8 00 0.00707 8 01 0.00707 |  | — | |
| 7 | 1450 8 01 2.01450 |  | — | | | 705 8 23 0.00705 |  | — | |



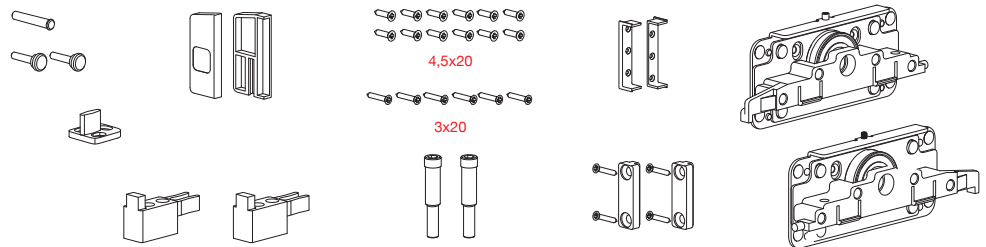

-  N.2 Soft damper stoppers
N.2 Fermi ammortizzati
-  Patented system
Sistema brevettato
-  Ball bearings
Cuscinetti a sfera
-  .01 Anodized Silver
Argento
-  .14 Anodized Black
Nero
-  .16 Anodized Nickel
Nichel
-  .26 Anodized Graphite
Grafite

| OLD CODE | NEW CODE | COLORS COLORI |  |  |  |
|--------------|-------------|-----------------------------|---|---|---|
| 1478/35G/12A | K.0051.2.01 | Anodized Silver / Argento | 40 kg | 12 mm | 4x |
| 1478/35G/12N | K.0051.2.14 | Anodized Black / Nero | | | 4x |
| — | K.0051.2.16 | Anodized Nickel / Nichel | | | 4x |
| — | K.0051.2.26 | Anodized Graphite / Grafite | | 18 mm | 4x |
| 1478/35G/18A | K.0053.2.01 | Anodized Silver / Argento | | | 4x |
| 1478/35G/18N | K.0053.2.14 | Anodized Black / Nero | | | 4x |
| — | K.0053.2.16 | Anodized Nickel / Nichel | | | 4x |
| — | K.0053.2.26 | Anodized Graphite / Grafite | | | 4x |
| 1478/80Y/12A | K.0052.2.01 | Anodized Silver / Argento | | | 80 kg |
| 1478/80Y/12N | K.0052.2.14 | Anodized Black / Nero | 4x | | |
| — | K.0052.2.16 | Anodized Nickel / Nichel | 4x | | |
| — | K.0052.2.26 | Anodized Graphite / Grafite | 18 mm | 4x | |
| 1478/80Y/18A | K.0054.2.01 | Anodized Silver / Argento | | 4x | |
| 1478/80Y/18N | K.0054.2.14 | Anodized Black / Nero | | 4x | |
| — | K.0054.2.16 | Anodized Nickel / Nichel | | 4x | |
| — | K.0054.2.26 | Anodized Graphite / Grafite | | 4x | |



-  N.2 Standard stoppers
N.2 Fermi standard
-  Patented system
Sistema brevettato
-  Ball bearings
Cuscinetti a sfera
-  .01 Anodized Silver
Argento
-  .14 Anodized Black
Nero
-  .16 Anodized Nickel
Nichel
-  .26 Anodized Graphite
Grafite

| OLD CODE | NEW CODE | COLORS COLORI |  |  |  |
|---------------|-------------|-----------------------------|---|---|---|
| 1478/1473/12A | K.0051.1.01 | Anodized Silver / Argento | 40 kg | 12 mm | 4x |
| 1478/1473/12N | K.0051.1.14 | Anodized Black / Nero | | | 4x |
| — | K.0051.1.16 | Anodized Nickel / Nichel | | | 4x |
| — | K.0051.1.26 | Anodized Graphite / Grafite | | 18 mm | 4x |
| 1478/1473/18A | K.0053.1.01 | Anodized Silver / Argento | | | 4x |
| 1478/1473/18N | K.0053.1.14 | Anodized Black / Nero | | | 4x |
| — | K.0053.1.16 | Anodized Nickel / Nichel | | | 4x |
| — | K.0053.1.26 | Anodized Graphite / Grafite | | | 4x |
| 1478/1477/12A | K.0052.1.01 | Anodized Silver / Argento | | | 80 kg |
| 1478/1477/12N | K.0052.1.14 | Anodized Black / Nero | 4x | | |
| — | K.0052.1.16 | Anodized Nickel / Nichel | 4x | | |
| — | K.0052.1.26 | Anodized Graphite / Grafite | 18 mm | 4x | |
| 1478/1477/18A | K.0054.1.01 | Anodized Silver / Argento | | 4x | |
| 1478/1477/18N | K.0054.1.14 | Anodized Black / Nero | | 4x | |
| — | K.0054.1.16 | Anodized Nickel / Nichel | | 4x | |
| — | K.0054.1.26 | Anodized Graphite / Grafite | | 4x | |

STANDARD HOLES AND MEASUREMENTS / FORATURE E MISURE STANDARD

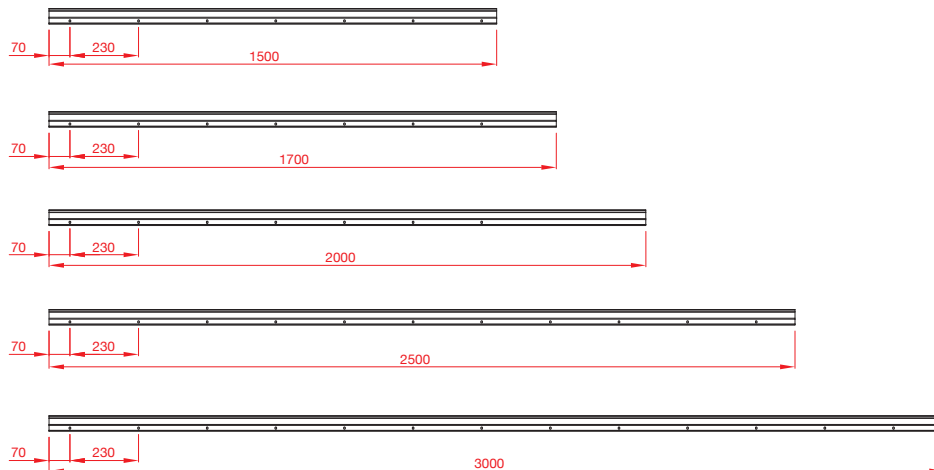

HOLES AND SIZES ON REQUEST / FORATURE E MISURE A RICHIESTA

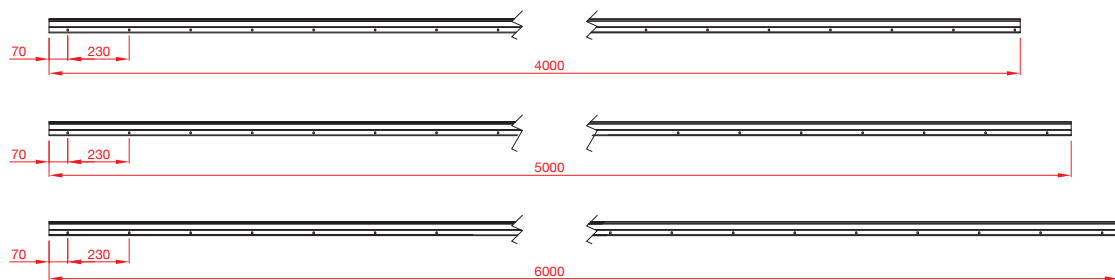

TRACKS / SPECIFY ARTICLE NUMBER, LENGTH AND COLOR WHEN ORDERING BINARI / AL MOMENTO DELL'ORDINE SPECIFICARE ARTICOLO, LUNGHEZZA E COLORE



ART. 1470
8 **02** 0.01470
8 **15** 0.01470
8 **17** 0.01470
8 **25** 0.01470



ART. 1450
8 **01** 2.01450
8 **14** 2.01450
8 **16** 2.01450
8 **26** 2.01450



ART. 1490
8 **01** 2.01490
8 **14** 2.01490
8 **16** 2.01490
8 **26** 2.01490



ART. 707
8 **00** 0.00707
8 **01** 0.00707



ART. 705
8 **23** 0.00705

00

Raw / Mill Finish
Neutro / Grezzo

01

Anodized Silver
Argento

02

Brushed Anodized Silver
Argento Spazzolato

14

Anodized Black
Nero

15

Brushed Anodized Black
Nero Spazzolato

16

Anodized Nickel
Nichel

17

Brushed Anodized Nickel
Nichel Spazzolato

25

Brushed Anodized Graphite
Grafite Spazzolato

26

Anodized Graphite
Grafite

STANDARD MEASUREMENTS DESCRIPTION / DESCRIZIONI MISURE STANDARD

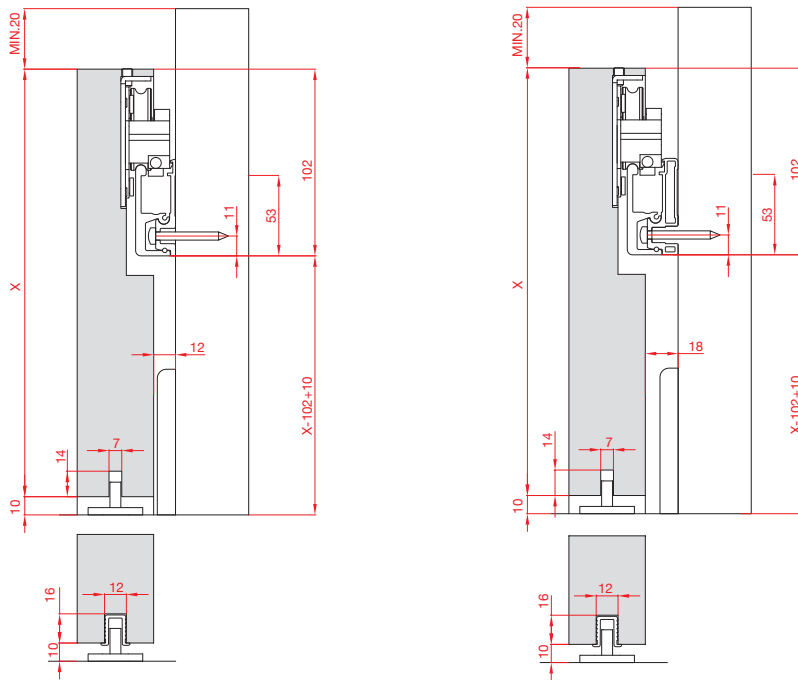

NOTES / NOTE

Specify the type of upright bar needed when ordering, based on the space desired between door panel and wall.

Definire all'ordine il tipo di trave necessario, in base allo spazio che si vorrà ottenere tra porta e parete.

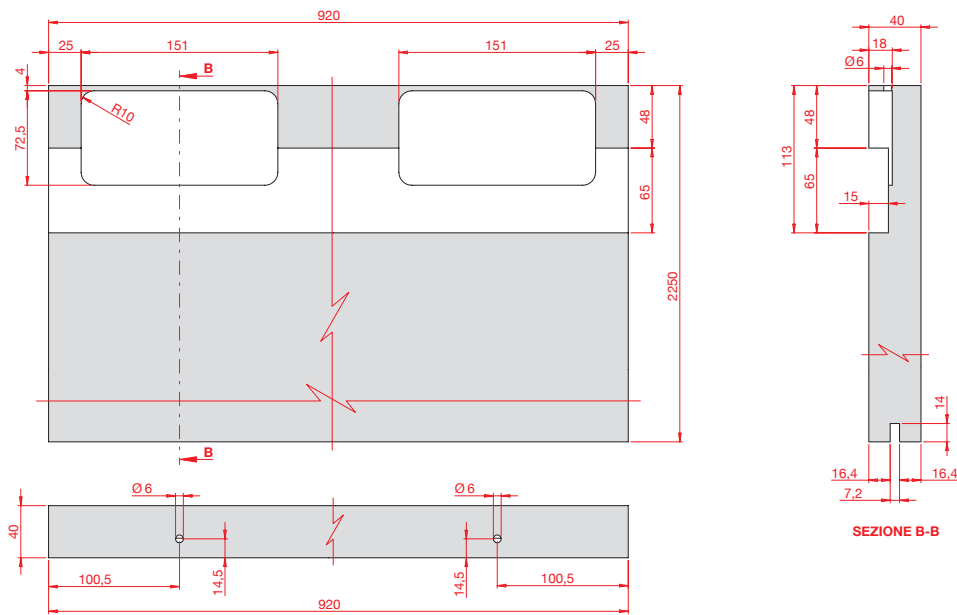

ASSEMBLY DESCRIPTION / DESCRIZIONE MONTAGGIO

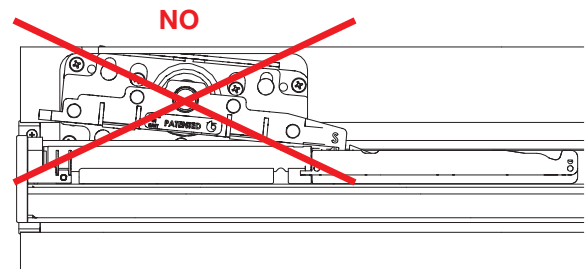
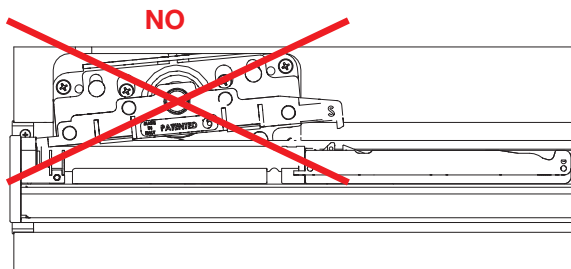

PAY ATTENTION ON THE TILT ASSEMBLY
PRESTARE ATTENZIONE ALL'INCLINAZIONE DEGLI ELEMENTI DURANTE IL MONTAGGIO



Diva Air Vetro

Sliding system for glass doors with amortized stopper
Scorrevoli per porte in vetro con fermo ammortizzato





Diva Air Vetro

Sliding system with amortized stopper
Scorrevoli per porte con fermo ammortizzato

Easy mounting



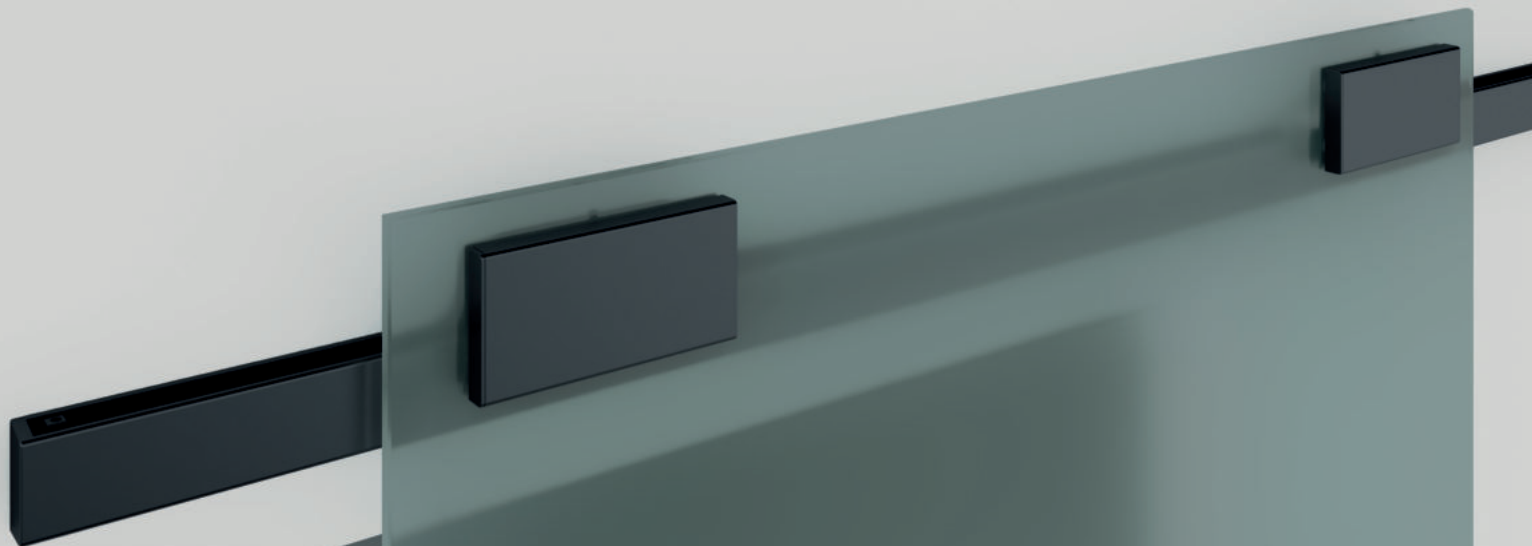

The air damper is integrated into the track and is equipped with an automatic loading system; the pre-loading operation must be made before the first usage of the door.

Facile da montare

L'ammortizzatore è inserito nel binario ed è dotato di caricamento automatico, da eseguire prima dell'utilizzo della porta.



PATENTED

| Diva Air Vetro | | COMPLETE BOX KIT / KIT COMPLETO IN SCATOLA | |  |
|-----------------------|---|---|--|---|
| K | Complete Diva Air kit for N°1 glass door / Kit completo Diva Air per N°1 porta in vetro | | | |
| | 0061 |  | Wall distance 31 mm Distanza dal muro 31 mm | |
| | 0062 |  | Wall distance 31 mm Distanza dal muro 31 mm | |
| | | 1 | N.2 Standard stoppers N.2 Fermi standard |  |
| | | 2 | N.2 Soft damper stoppers N.2 Fermi ammortizzati |  |
| | | | | 01 Anodized Silver / Argento |
| | | | | 14 Anodized Black / Nero |
| | | | | 16 Anodized Nickel / Nichel |
| | | | | 26 Anodized Graphite / Grafite |

EXAMPLE / ESEMPIO

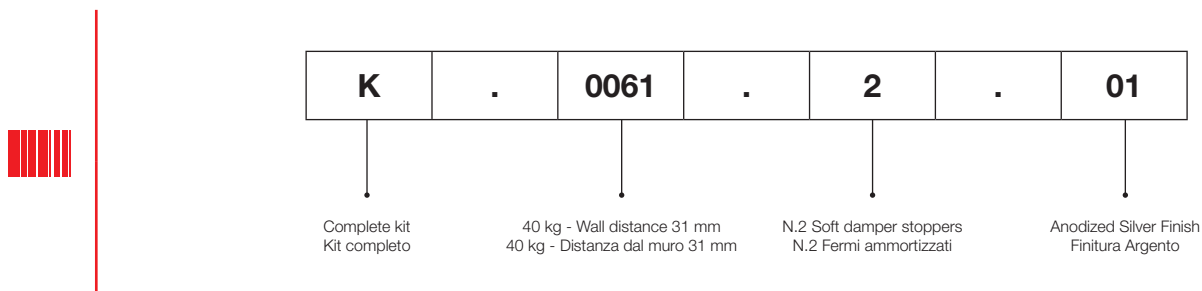

| Tracks / Binari | | ALUMINUM FINISHES CODES / CODICI FINITURE ALLUMINIO | |  |
|------------------------|---|---|--|---|
| CODE / CODICE | | | FINISH COLOR / COLORE FINITURA | |
| 8 00 0.0 |  | 00 G | Raw / Mill Finish / Neutro / Grezzo | STANDARD |
| 8 01 0.0 |  | 01 A | Anodized Silver / Argento | |
| 8 02 0.0 |  | 02 AS | Brushed Anodized Silver / Argento Spazzolato | |
| 8 14 0.0 |  | 14 N | Anodized Black / Nero | SPECIAL |
| 8 15 0.0 |  | 15 NS | Brushed Anodized Black / Nero Spazzolato | |
| 8 16 0.0 |  | 16 NK | Anodized Nickel / Nichel | |
| 8 17 0.0 |  | 17 NKS | Brushed Anodized Nickel / Nichel Spazzolato | |
| 8 25 0.0 |  | 25 GRFS | Brushed Anodized Graphite / Grafite Spazzolato | |
| 8 26 0.0 |  | 26 GRF | Anodized Graphite / Grafite | |

Diva Air Vetro

Sliding system with amortized stopper
Scorrevoli per porte con fermo ammortizzato

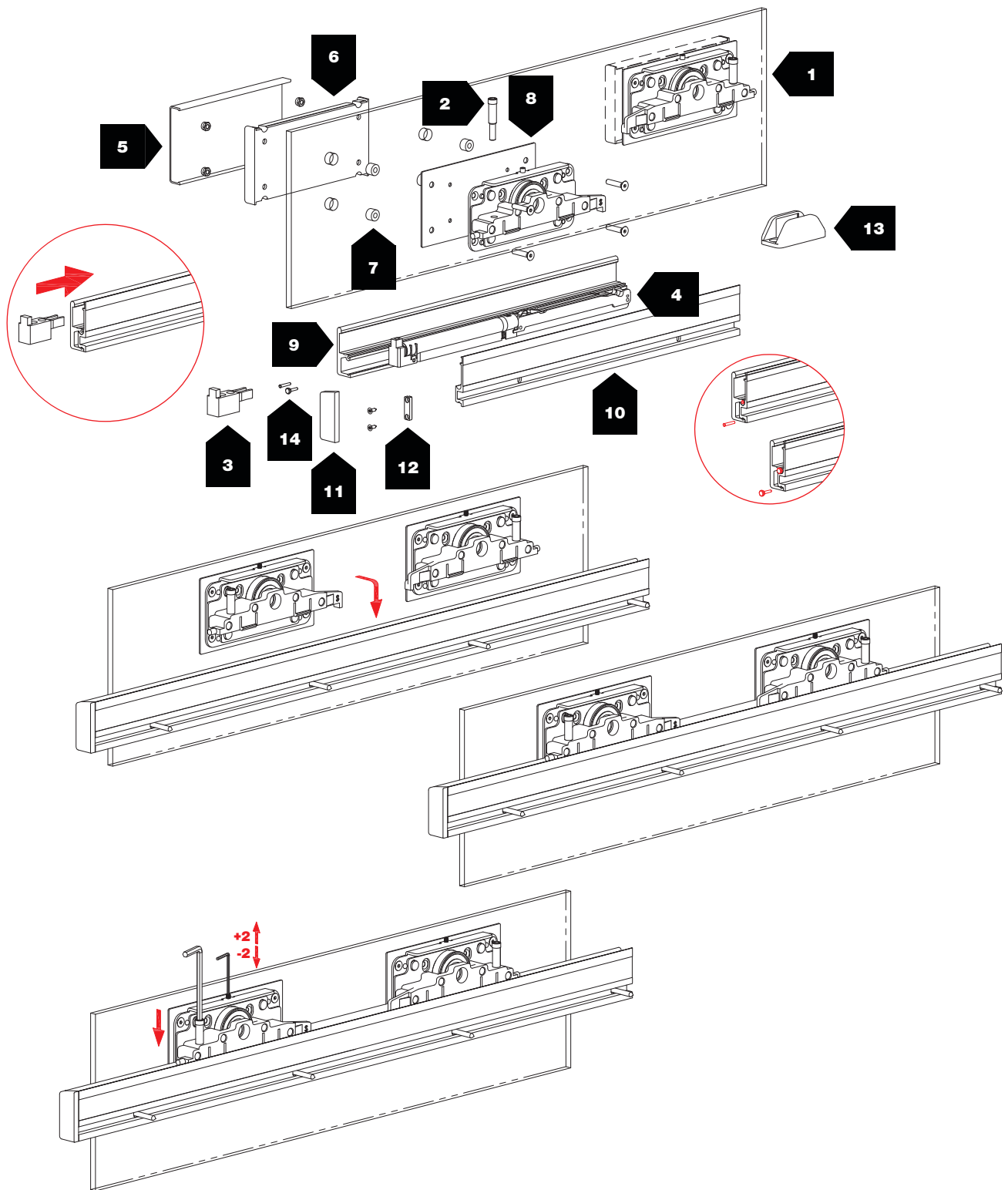

31 mm



40 - 80 kg



10 mm

COLORS / COLORI

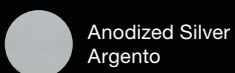

Anodized Silver
Argento

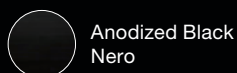

Anodized Black
Nero

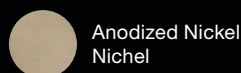

Anodized Nickel
Nichel

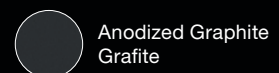

Anodized Graphite
Grafite



| N° | Barcode | Image | kg | | N° | Barcode | Image | kg | |
|----|----------|-------|-------|--|----|----------------------|-------|----|--|
| 1 | 1478 | | 40÷80 | | 8 | 1482 | | - | |
| 2 | 1479 | | - | | 9 | 1470 8 02 0.01470 | | - | |
| 3 | 1473 | | 40 | | 10 | 1450 8 01 2.01450 | | - | |
| | 1477 | | 80 | | | | | | |
| 4 | 1476/35G | | 40 | | 11 | 1474 | | - | |
| | 1476/80Y | | 80 | | 12 | 1472 | | - | |
| 5 | 1349/161 | | - | | 13 | 1486/8/10/12 | | - | |
| 6 | 1484 | | - | | 14 | 1337 | | - | |
| 7 | 1341 | | - | | | 1333 | | - | |

Diva Air Vetro

Sliding system with amortized stopper
Scorrevoli per porte con fermo ammortizzato

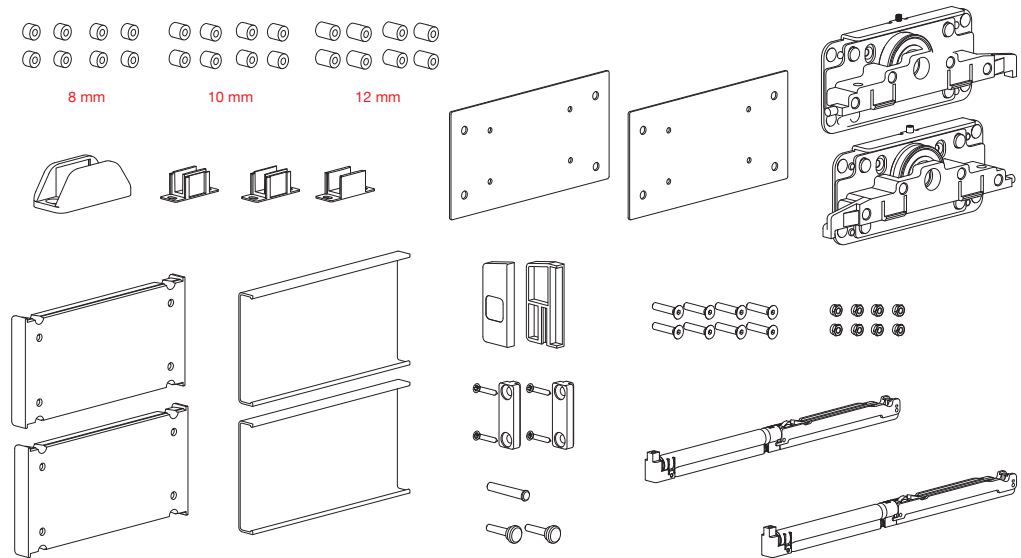

-  N.2 Soft damper stoppers
N.2 Fermi ammortizzati
-  Patented system
Sistema brevettato
-  Ball bearings
Cuscinetti a sfera
- .01** Anodized Silver
Argento
- .14** Anodized Black
Nero
- .16** Anodized Nickel
Nichel
- .26** Anodized Graphite
Grafite

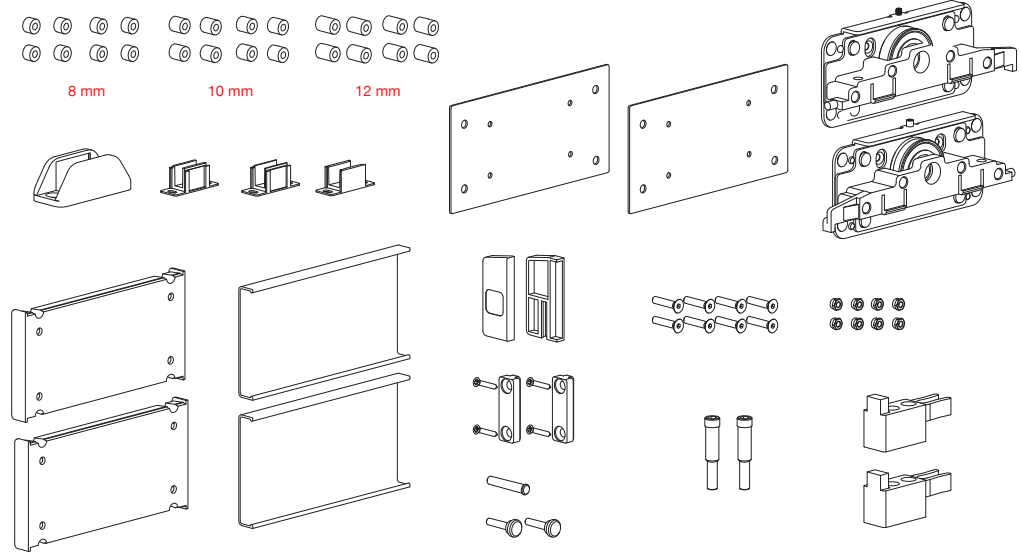

| OLD CODE | NEW CODE | COLORS COLORI |  |  |  |
|----------------|-------------|-----------------------------|---|---|---|
| 1478/1349/35GA | K.0061.2.01 | Anodized Silver / Argento | 40 kg | 31 mm | 6x |
| 1478/1349/35GN | K.0061.2.14 | Anodized Black / Nero | | | 6x |
| — | K.0061.2.16 | Anodized Nickel / Nichel | | | 6x |
| — | K.0061.2.26 | Anodized Graphite / Grafite | | | 6x |
| 1478/1349/80YA | K.0062.2.01 | Anodized Silver / Argento | 80 kg | 31 mm | 6x |
| 1478/1349/80YN | K.0062.2.14 | Anodized Black / Nero | | | 6x |
| — | K.0062.2.16 | Anodized Nickel / Nichel | | | 6x |
| — | K.0062.2.26 | Anodized Graphite / Grafite | | | 6x |

-  N.2 Standard stoppers
N.2 Fermi standard
-  Patented system
Sistema brevettato
-  Ball bearings
Cuscinetti a sfera
- .01** Anodized Silver
Argento
- .14** Anodized Black
Nero
- .16** Anodized Nickel
Nichel
- .26** Anodized Graphite
Grafite



| OLD CODE | NEW CODE | COLORS COLORI |  |  |  |
|-----------------|-------------|-----------------------------|---|---|---|
| 1478/1349/P40/A | K.0061.1.01 | Anodized Silver / Argento | 40 kg | 31 mm | 6x |
| 1478/1349/P40/N | K.0061.1.14 | Anodized Black / Nero | | | 6x |
| — | K.0061.1.16 | Anodized Nickel / Nichel | | | 6x |
| — | K.0061.1.26 | Anodized Graphite / Grafite | | | 6x |
| 1478/1349/P80/A | K.0062.1.01 | Anodized Silver / Argento | 80 kg | 31 mm | 6x |
| 1478/1349/P80/N | K.0062.1.14 | Anodized Black / Nero | | | 6x |
| — | K.0062.1.16 | Anodized Nickel / Nichel | | | 6x |
| — | K.0062.1.26 | Anodized Graphite / Grafite | | | 6x |

STANDARD HOLES AND MEASUREMENTS / FORATURE E MISURE STANDARD

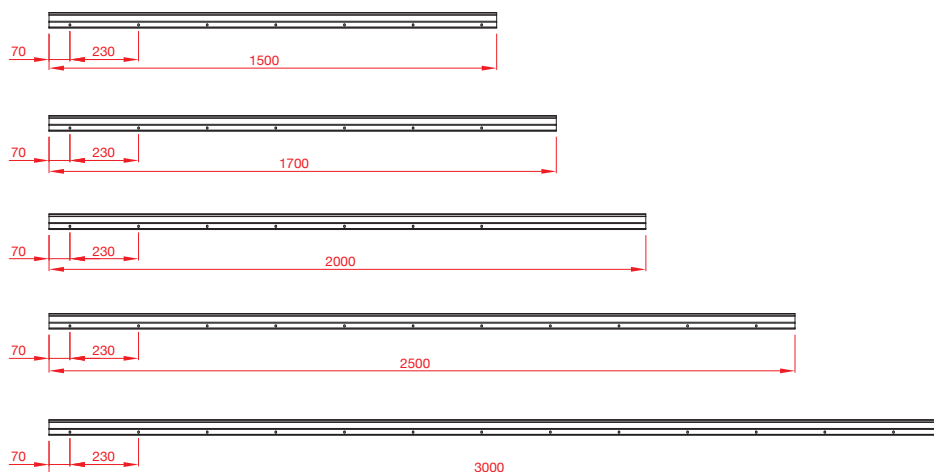

HOLES AND SIZES ON REQUEST / FORATURE E MISURE A RICHIESTA

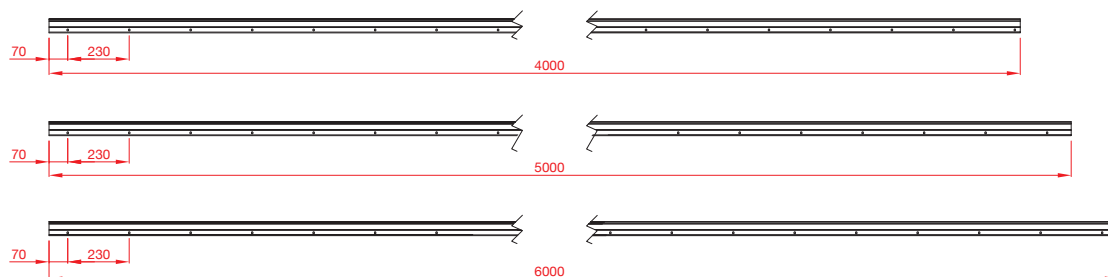

TRACKS / SPECIFY ARTICLE NUMBER, LENGTH AND COLOR WHEN ORDERING BINARI / AL MOMENTO DELL'ORDINE SPECIFICARE ARTICOLO, LUNGHEZZA E COLORE



ART. 1470
8 **02** 0.01470
8 **15** 0.01470
8 **17** 0.01470
8 **25** 0.01470



ART. 1450
8 **01** 2.01450
8 **14** 2.01450
8 **16** 2.01450
8 **26** 2.01450

| | |
|-----------|---|
| 01 | Anodized Silver Argento |
| 02 | Brushed Anodized Silver Argento Spazzolato |
| 14 | Anodized Black Nero |
| 15 | Brushed Anodized Black Nero Spazzolato |
| 16 | Anodized Nickel Nichel |
| 17 | Brushed Anodized Nickel Nichel Spazzolato |
| 25 | Brushed Anodized Graphite Grafite Spazzolato |
| 26 | Anodized Graphite Grafite |

STANDARD HOLES AND MEASUREMENTS / FORATURE E MISURE STANDARD

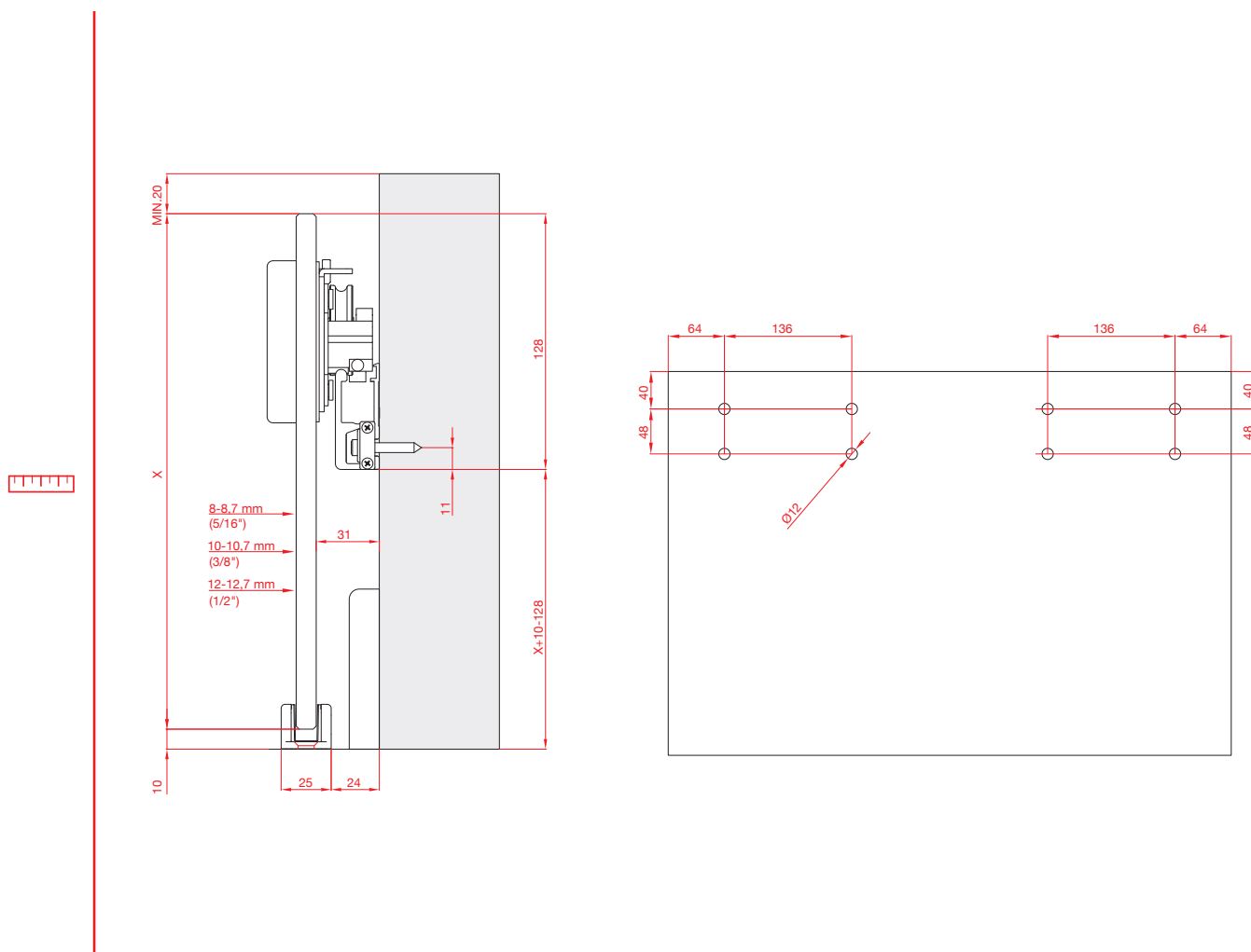



terno[®] scorrevoli
M A D E I N I T A L Y

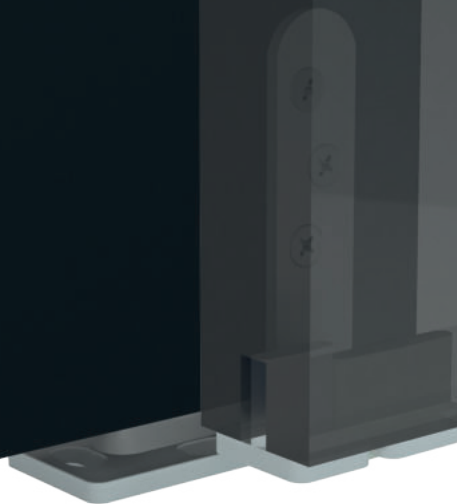

Drag

Mechanisms for wooden drag doors
Meccanismi per porte in legno a trascinamento

www.ternoscorrevoli.com/drag



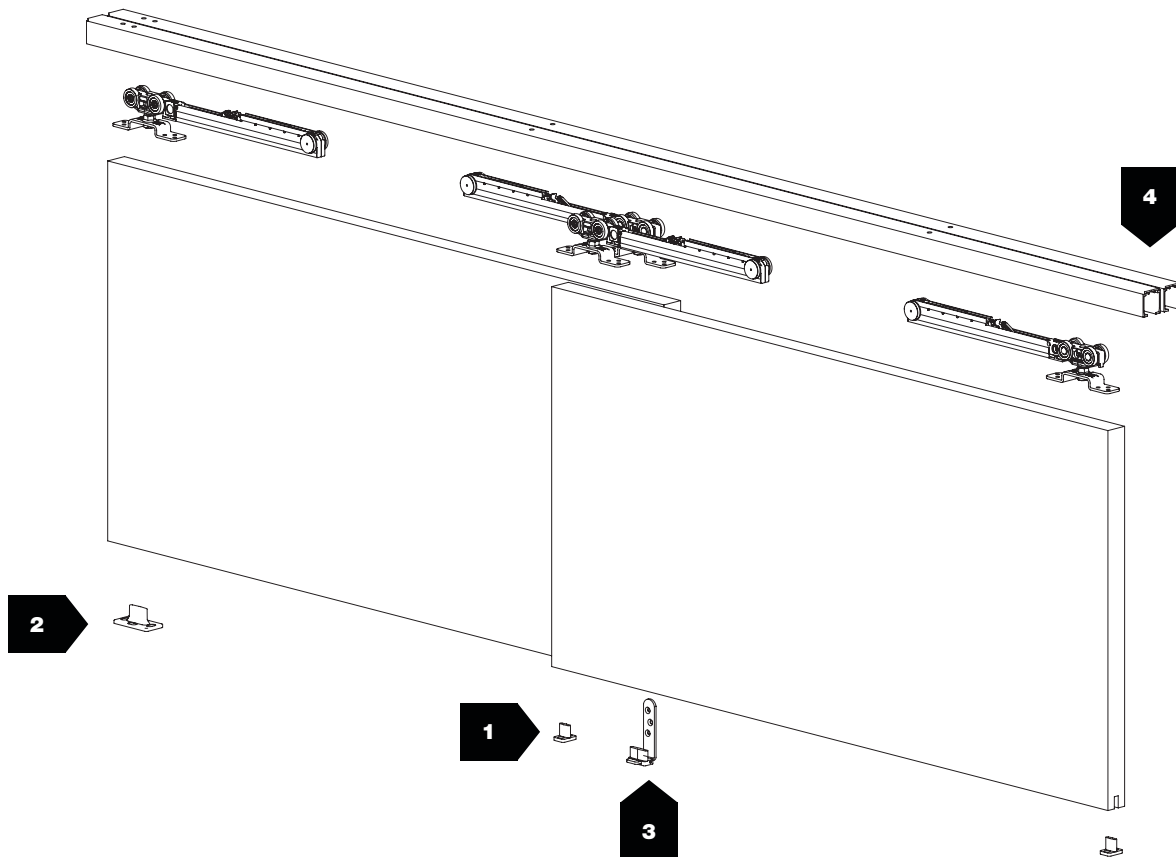

DRAG SYSTEM COMPATIBLE WITH / SISTEMA TRASCINAMENTO COMPATIBILE CON:

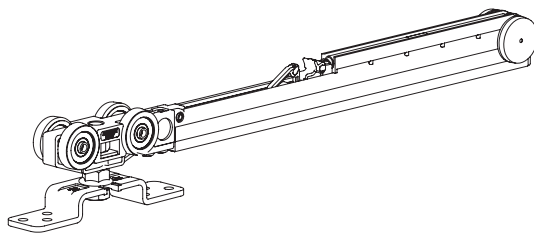

CLASSIC
STANDARD BRACKET
STAFFA NORMALE



NEW

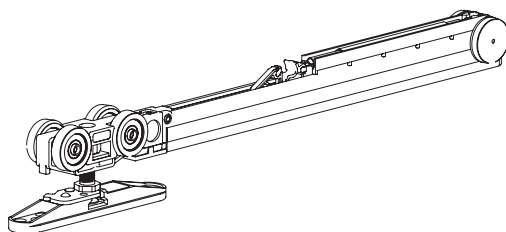

STEP
FRONTAL AUTOMATIC CLAMP
STAFFA AUTOMATICA FRONTALE



NEW







Min 25 mm - Max 50 mm



80 kg

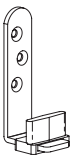

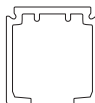
10 mm

| N° | Barcode | | kg | | N° | Barcode | | kg | |
|----|----------------|---|----|--|----|--------------------------------------|---|----|--|
| 1 | 1032 S.1032 |  | 80 | | 3 | 71 S.71/G |  | 80 | |
| 2 | 65 S.65 |  | 80 | | 4 | 1280 8 00 0.01280 8 01 0.01280 |  | - | |
| | | | | | | 1080 8 00 0.01080 8 01 0.01080 |  | - | |

| Tracks / Binari | | ALUMINUM FINISHES CODES / CODICI FINITURE ALLUMINIO | |  |
|-----------------|---|---|---|---|
| CODE / CODICE | | FINISH COLOR / COLORE FINITURA | | |
| 8 00 0.0 |  | 00 | G | Row - Mill Finish / Neutro - Grezzo |
| 8 01 0.0 |  | 01 | A | Anodized Silver / Argento |
| | | | | STANDARD |

ADJUSTABLE ACCESSORIES FOR DRAGGING OF SLIDING DOORS
ACCESSORI REGOLABILI PER TRASCINAMENTO PORTE SCORREVOLI

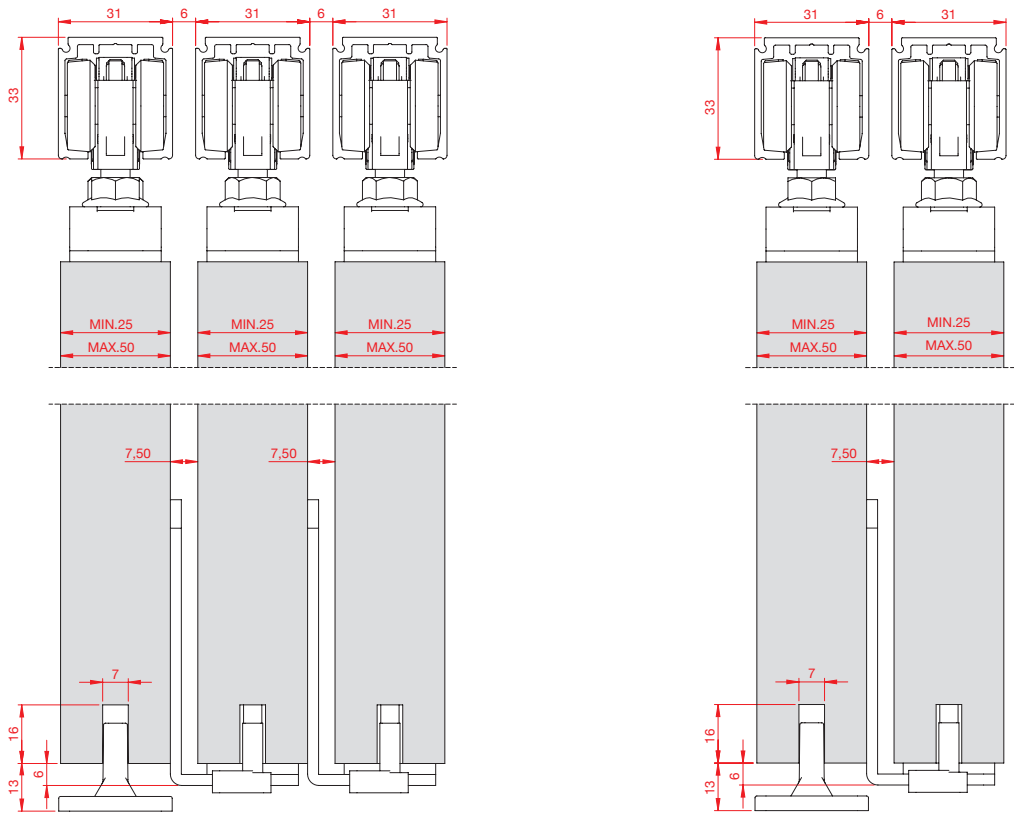

EXAMPLE WITH N°2 LEAVES (FOR EVERY EXTRA LEAF, ADD N°2 ART. 1032 AND N°1 ART. 71)
ESEMPIO CON N°2 ANTE, (PER OGNI ANTA IN PIÙ AGGIUNGERE N°2 ART. 1032 E N°1 ART. 71)

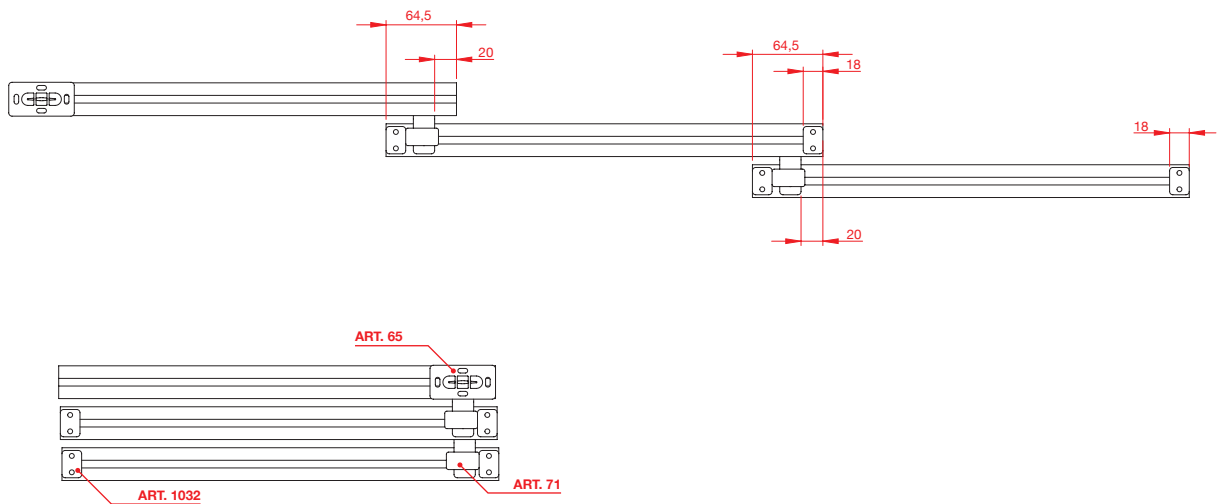

Stopper
Fermo
ART. 1032



Bottom guide
Guida inferiore
ART. 65

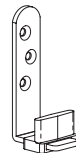

Adjustable bottom guide
Guida inferiore regolabile
ART. 71



Eclettica

Automatic lateral bracket system
Scorrevoli con staffa automatica laterale

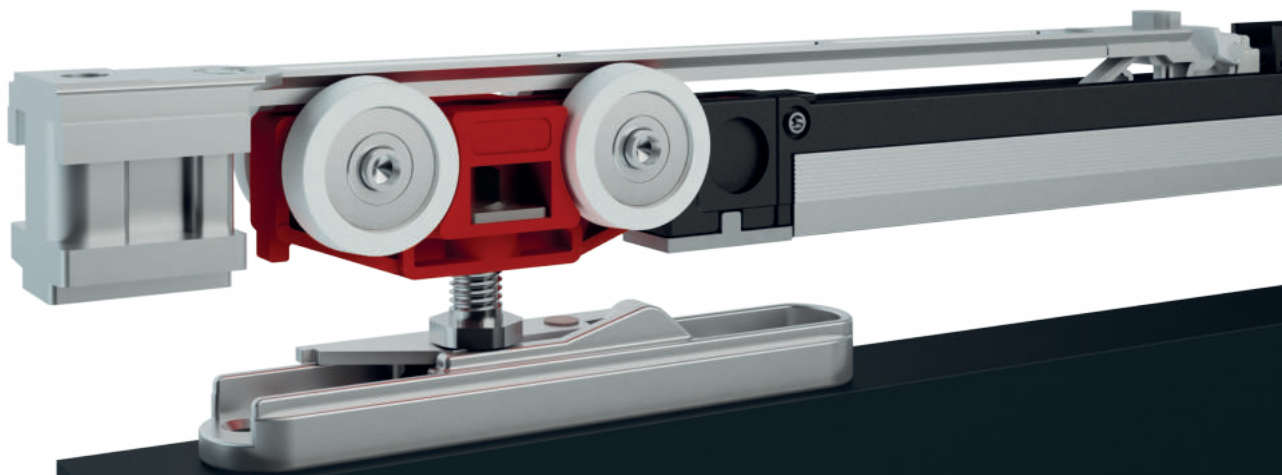



Eclettica Automatic lateral bracket system
Scorrevoli con staffa automatica laterale

New automatic lateral coupler bracket

With possible embedded by milling or clip-on style.

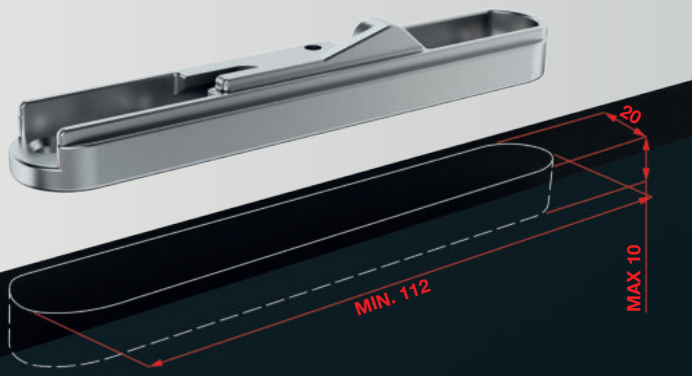
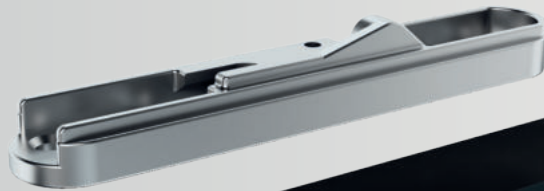

Nuova staffa ad innesto automatico laterale

Possibilità di incasso con fresata oppure fissaggio in appoggio.

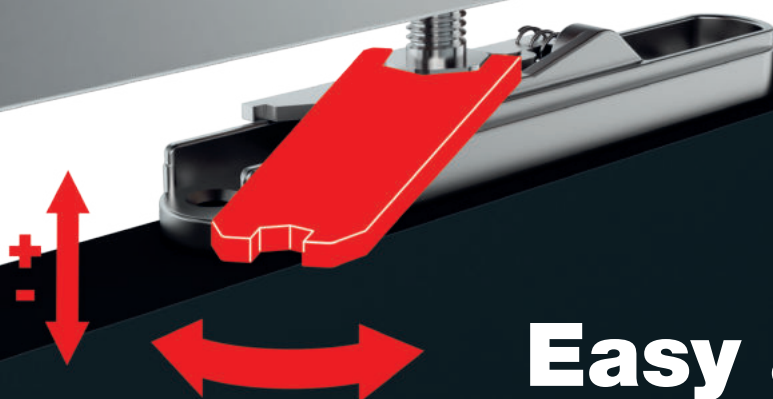
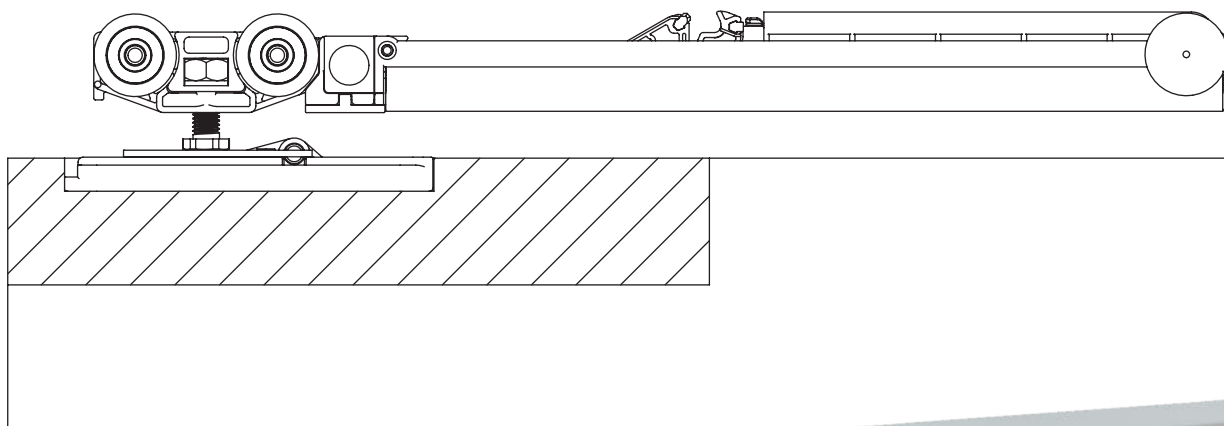

Easy adjusting
Facile da regolare



LEFT / SINISTRO

RIGHT / DESTRO

Easy mounting

Position the brackets (right and left) as shown in the drawing.

Facile da montare

Posizionare le staffe (sinistra e destra) come da disegno.

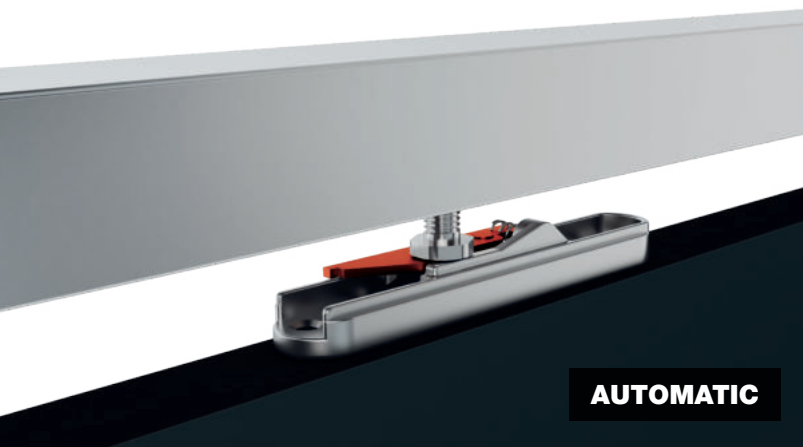

AUTOMATIC

Hooking system

The trolley can be automatically engaged in the brackets by simply positioning and pressing the pin on the bracket lever.

1

Sistema di aggancio

Il carrello si inserisce automaticamente nella staffa, semplicemente appoggiandolo e spingendo il perno sulla leva della staffa stessa.

Release system

To release the trolley, hand operate the spring lever.

Sistema di sgancio

Per sganciare il carrello, agire manualmente sulla leva a molla.

2

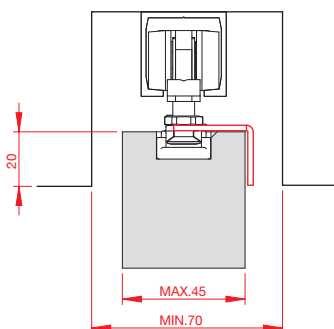
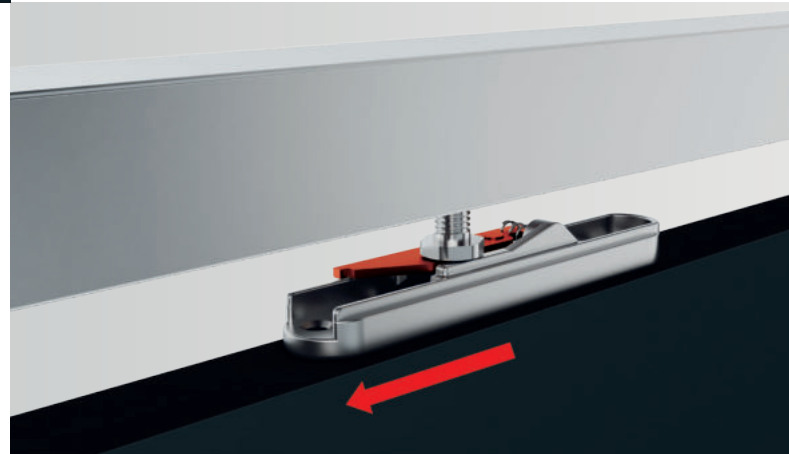

Folded lever

In order to encase the door into the ceiling use the folded lever.
(Add the code "LP" to the selected sliding article).

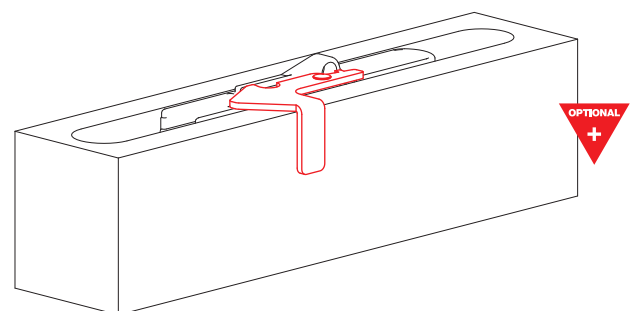

Leva piegata



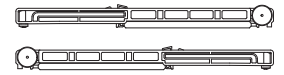
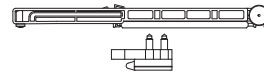

















Per poter incassare la porta nel soffitto utilizzare la leva piegata.
(Aggiungere il codice "LP" all'articolo dello scorrevole prescelto).



**N.2 STANDARD STOPPERS
N.2 FERMI STANDARD**

**N.1 SOFT DAMPER STOPPER +
N.1 STANDARD STOPPER
N.1 FERMO AMMORTIZZATO +
N.1 FERMO STANDARD**

**N.2 SOFT DAMPER STOPPERS
N.2 FERMI AMMORTIZZATI**

| | | | |
|---|--|---|--|
|  30 kg |   Min. 600 mm PAG. 12 |   Min. 600 mm PAG. 12 |   Min. 600 mm PAG. 12 |
|  50 kg | | | |
|  80 kg |   Min. 600 mm PAG. 15 | | |
|  120 kg | | | |
|  160 kg |   Min. 700 mm PAG. 17 | | |
|  180 kg | | | |
|  240 kg |   Min. 700 mm PAG. 18 | | |
|  250 kg | | | |

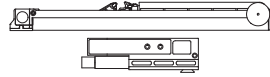
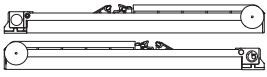

N.2 FLUID DAMPERS
N.2 FERMI AMMORTIZZATI FLUID

N.1 FLUID DAMPER + N.1 SHOCK ABSORBER
N.1 FERMO AMMORTIZZATO FLUID + N.1 FERMO A PINZA AMMORTIZZATO

N.2 SHOCK ABSORBERS
N.2 FERMI A PINZA AMMORTIZZATI

N.2 HYDRAULIC STOPPERS (NAVAL SECTOR)
N.2 FERMI IDRAULICI (SETTORE NAVALE)

| | | | |
|------------------------|------------------------|------------------------|----------------|
| | | | |
| ● | ● | ● | |
| NEW Min. 740 mm | NEW Min. 600 mm | NEW Min. 600 mm | |
| PAG. 13 | PAG. 13 | PAG. 13 | |
| ● | ● | ● | ● |
| NEW Min. 740 mm | NEW Min. 600 mm | NEW Min. 600 mm | Min. 700 mm |
| PAG. 14 | PAG. 14 | PAG. 14 | PAG. 15 |
| ● | ● | ● | |
| NEW Min. 740 mm | NEW Min. 600 mm | NEW Min. 600 mm | |
| PAG. 16 | PAG. 16 | PAG. 16 | |
| | | ● | |
| | | NEW Min. 700 mm | |
| | | PAG. 17 | |
| | | ● | |
| | | NEW Min. 700 mm | |
| | | PAG. 18 | |

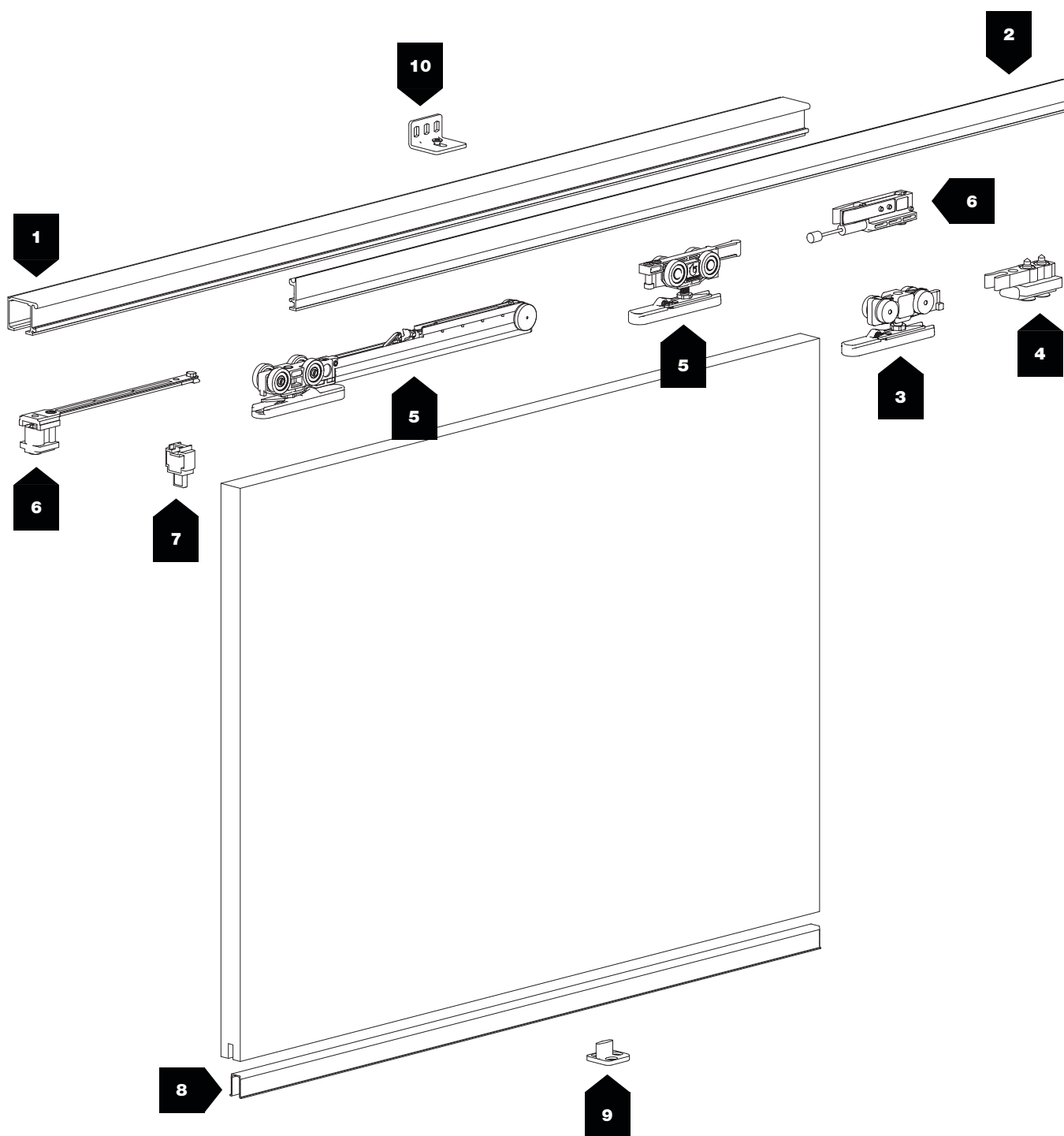

600 ÷ 1500 mm











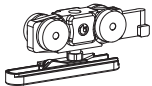
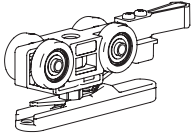
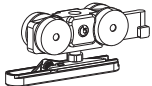
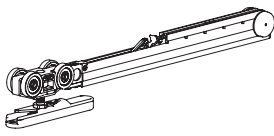
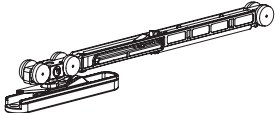
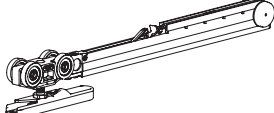

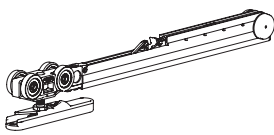
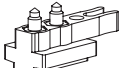
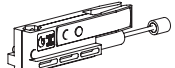
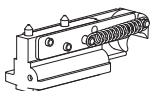
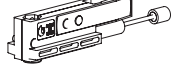
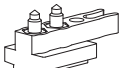
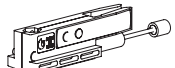
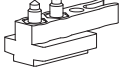
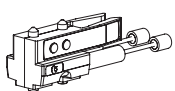

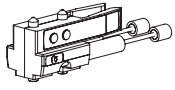
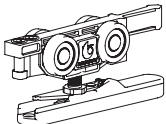
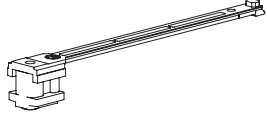



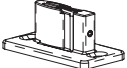

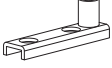

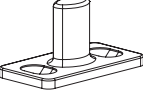
30 ÷ 250 kg

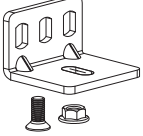

6 ÷ 15 mm

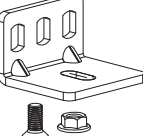
| N° | Barcode | kg | | N° | Barcode | kg | | | | |
|----|--------------------------------------|----|---|------------|---------|--------------------------------------|----------------------|---|------------------------|--------------------------|
| 1 | 2660 8 00 0.02660 8 01 0.02660 | | - | STANDARD | 1 | 3480 8 00 0.03480 8 01 0.03480 | | - | STANDARD NEW | |
| | 2670 8 00 0.02670 8 01 0.02670 | | - | OPTIONAL + | | 201 8 00 0.00201 8 01 0.00201 | | - | STANDARD | |
| | 1280 8 00 0.01280 8 01 0.01280 | | - | STANDARD | | 234 8 00 0.00234 8 01 0.00234 | | - | OPTIONAL + | |
| | 1080 8 00 0.01080 8 01 0.01080 | | - | OPTIONAL + | | 1710 8 00 0.01710 8 01 0.01710 | | - | OPTIONAL + | |
| | 1359 8 00 0.01359 8 01 0.01359 | | - | OPTIONAL + | | 1720 8 00 0.01720 8 01 0.01720 | | - | OPTIONAL + | |
| | 1559 8 00 0.01559 8 01 0.01559 | | - | OPTIONAL + | | 2 | 3490 8 02 0.03490 | | - | OPTIONAL + NEW |
| | 1700 8 00 0.01700 8 01 0.01700 | | - | OPTIONAL + | | | 3491 | | - | OPTIONAL + NEW |
| | 1160 8 00 0.01160 8 01 0.01160 | | - | STANDARD | | | 2667/T | | 30 | |
| | 160 8 00 0.00160 8 01 0.00160 | | - | OPTIONAL + | | 3 | 83/T | | 80 | |
| | 1660 8 00 0.01660 8 01 0.01660 | | - | OPTIONAL + | | | 1634/T | | 80 | |

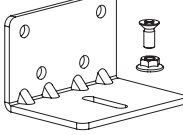
| N° | | | kg | | N° | | | kg | |
|----|---------|---|--------|--------------|----|----------|---|---------|--------------|
| 3 | 1168/T |  | 160 | | 5 | 3518 |  | 180÷250 | FLUID NEW |
| | 208/T |  | 240 | | | 3382/050 |  | 50 | FLUID NEW |
| | 2666/T |  | 30 | | | 3382/080 |  | 80 | FLUID NEW |
| 4 | 2657 |  | 30 | | 5 | 3382/120 |  | 120 | FLUID NEW |
| | 84 |  | 80 | | | 3355/050 |  | 50 | FLUID NEW |
| | 1627/10 |  | 80 | | | 3355/080 |  | 80 | FLUID NEW |
| | 1163 |  | 160 | | 6 | 3355/120 |  | 120 | FLUID NEW |
| | 1165 |  | 240 | | | 3485/180 |  | 180 | FLUID NEW |
| | 2661 |  | 30 | | | 3485/250 |  | 250 | FLUID NEW |
| | 3388 |  | 50÷120 | FLUID NEW | | 3354 |  | 50÷120 | FLUID NEW |

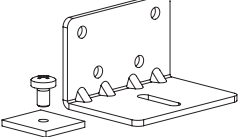
| N° | Barcode | | kg | | N° | Barcode | | kg | |
|----|-------------------------------------|---|---------|------------|----|---------|---|---------|------------|
| 7 | 3347 |  | — | | 90 | |  | 30÷120 | OPTIONAL + |
| 8 | 121 8 23 0.00121 |  | 30÷120 | OPTIONAL + | 9 | 124 |  | 160÷240 | |
| | 705 8 23 0.00705 |  | 50÷120 | OPTIONAL + | | 2855 |  | 180÷250 | NEW |
| | 707 8 00 0.00707 8 01 0.00707 |  | 50÷120 | OPTIONAL + | | 409 |  | — | |
| | 760/N 8 14 0.00760 |  | 160÷240 | | | 126 |  | 30 | |
| 9 | 1032 |  | 30 | | 10 | 127/D/V |  | 50÷120 | |
| | 45 |  | 50÷80 | | | 163/DV |  | 160÷250 | |
| | 93 |  | 120 | | | 163/PV |  | 160÷250 | |

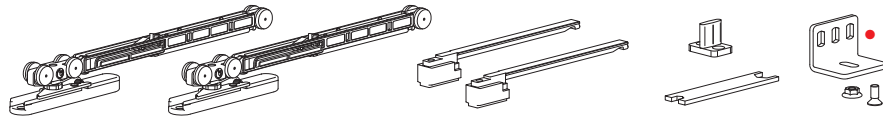

ART. 2660
(8000.02660)
(8010.02660)

30 kg

N.2 Soft damper stoppers
N.2 Fermi ammortizzati

Turned wheels
Ruote tornite

| | | OLD CODE | NEW CODE | | TRACK-BINARIO | |
|----------------|--------|----------------|-----------------------|----------------|---------------|----|
| KIT | ● N° 3 | 2666/2666/G/C | K.030.6.4.C | Min. 600 mm | — | 4x |
| | — | 2666/2666/G/S | K.030.6.4.S | Min. 600 mm | — | 4x |
| BLISTER | N° 4 | 2666/2666/150C | B.030.6.4.C150 | 700 ÷ 850 mm | 1500 mm | 4x |
| | N° 5 | 2666/2666/165C | B.030.6.4.C165 | 860 ÷ 950 mm | 1650 mm | 4x |
| | ● N° 5 | 2666/2666/200C | B.030.6.4.C200 | 960 ÷ 1100 mm | 2000 mm | 4x |
| | N° 6 | 2666/2666/250C | B.030.6.4.C250 | 1110 ÷ 1350 mm | 2500 mm | 4x |
| | N° 7 | 2666/2666/300C | B.030.6.4.C300 | 1360 ÷ 1600 mm | 3000 mm | 4x |
| | — | 2666/2666/150S | B.030.6.4.S150 | 700 ÷ 850 mm | 1500 mm | 4x |
| | — | 2666/2666/165S | B.030.6.4.S165 | 860 ÷ 950 mm | 1650 mm | 4x |
| | — | 2666/2666/200S | B.030.6.4.S200 | 960 ÷ 1100 mm | 2000 mm | 4x |
| | — | 2666/2666/250S | B.030.6.4.S250 | 1110 ÷ 1350 mm | 2500 mm | 4x |
| | — | 2666/2666/300S | B.030.6.4.S300 | 1360 ÷ 1600 mm | 3000 mm | 4x |

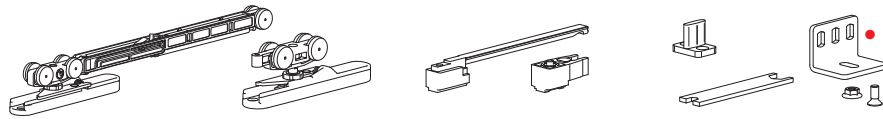

ART. 2660
(8000.02660)
(8010.02660)

30 kg

N.1 Soft damper stopper
N.1 Fermo ammortizzato

N.1 Standard stopper
N.1 Fermo standard

Turned wheels
Ruote tornite

| | | OLD CODE | NEW CODE | | TRACK-BINARIO | |
|----------------|--------|----------------|-----------------------|----------------|---------------|----|
| KIT | ● N° 3 | 2666/2667/G/C | K.030.5.4.C | Min. 600 mm | — | 4x |
| | — | 2666/2667/G/S | K.030.5.4.S | Min. 600 mm | — | 4x |
| BLISTER | N° 4 | 2666/2667/150C | B.030.5.4.C150 | 700 ÷ 850 mm | 1500 mm | 4x |
| | N° 5 | 2666/2667/165C | B.030.5.4.C165 | 860 ÷ 950 mm | 1650 mm | 4x |
| | ● N° 5 | 2666/2667/200C | B.030.5.4.C200 | 960 ÷ 1100 mm | 2000 mm | 4x |
| | N° 6 | 2666/2667/250C | B.030.5.4.C250 | 1110 ÷ 1350 mm | 2500 mm | 4x |
| | N° 7 | 2666/2667/300C | B.030.5.4.C300 | 1360 ÷ 1600 mm | 3000 mm | 4x |
| | — | 2666/2667/150S | B.030.5.4.S150 | 700 ÷ 850 mm | 1500 mm | 4x |
| | — | 2666/2667/165S | B.030.5.4.S165 | 860 ÷ 950 mm | 1650 mm | 4x |
| | — | 2666/2667/200S | B.030.5.4.S200 | 960 ÷ 1100 mm | 2000 mm | 4x |
| | — | 2666/2667/250S | B.030.5.4.S250 | 1110 ÷ 1350 mm | 2500 mm | 4x |
| | — | 2666/2667/300S | B.030.5.4.S300 | 1360 ÷ 1600 mm | 3000 mm | 4x |

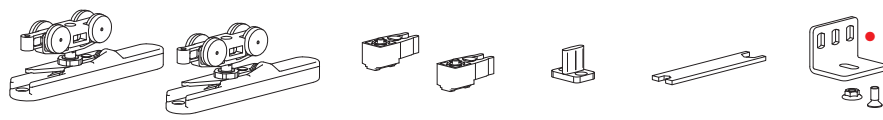

ART. 2660
(8000.02660)
(8010.02660)

30 kg

N.2 Standard stoppers
N.2 Fermi standard

Turned wheels
Ruote tornite

| | | OLD CODE | NEW CODE | | TRACK-BINARIO | |
|----------------|--------|----------------|-----------------------|----------------|---------------|----|
| KIT | ● N° 3 | 2667/2667/G/C | K.030.0.4.C | Min. 600 mm | — | 5x |
| | — | 2667/2667/G/S | K.030.0.4.S | Min. 600 mm | — | 5x |
| BLISTER | N° 4 | 2667/2667/150C | B.030.0.4.C150 | 700 ÷ 850 mm | 1500 mm | 4x |
| | N° 5 | 2667/2667/165C | B.030.0.4.C165 | 860 ÷ 950 mm | 1650 mm | 4x |
| | ● N° 5 | 2667/2667/200C | B.030.0.4.C200 | 960 ÷ 1100 mm | 2000 mm | 4x |
| | N° 6 | 2667/2667/250C | B.030.0.4.C250 | 1110 ÷ 1350 mm | 2500 mm | 4x |
| | N° 7 | 2667/2667/300C | B.030.0.4.C300 | 1360 ÷ 1600 mm | 3000 mm | 4x |
| | — | 2667/2667/150S | B.030.0.4.S150 | 700 ÷ 850 mm | 1500 mm | 4x |
| | — | 2667/2667/165S | B.030.0.4.S165 | 860 ÷ 950 mm | 1650 mm | 4x |
| | — | 2667/2667/200S | B.030.0.4.S200 | 960 ÷ 1100 mm | 2000 mm | 4x |
| | — | 2667/2667/250S | B.030.0.4.S250 | 1110 ÷ 1350 mm | 2500 mm | 4x |
| | — | 2667/2667/300S | B.030.0.4.S300 | 1360 ÷ 1600 mm | 3000 mm | 4x |

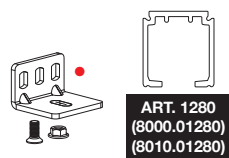
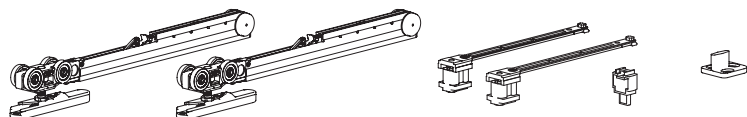

| | | OLD CODE | NEW CODE | | TRACK-BINARIO | |
|----------------|---|----------|----------|-----------------------|-------------------|---------|
| KIT | • | N° 4 | — | K.050.2.4.C | Min. 740 mm | 4x |
| | | — | — | K.050.2.4.S | Min. 740 mm | 4x |
| BLISTER | • | N° 4 | — | B.050.2.4.C150 | 740 ÷ 850 mm | 1500 mm |
| | | N° 5 | — | B.050.2.4.C165 | 860 ÷ 950 mm | 1650 mm |
| | | N° 5 | — | B.050.2.4.C200 | 960 ÷ 1100 mm | 2000 mm |
| | | N° 6 | — | B.050.2.4.C250 | 1110 ÷ 1350 mm | 2500 mm |
| | | N° 7 | — | B.050.2.4.C300 | 1360 ÷ 1600 mm | 3000 mm |
| | | — | — | B.050.2.4.S150 | 700 ÷ 850 mm | 1500 mm |
| | | — | — | B.050.2.4.S165 | 860 ÷ 950 mm | 1650 mm |
| | | — | — | B.050.2.4.S200 | 960 ÷ 1100 mm | 2000 mm |
| | | — | — | B.050.2.4.S250 | 1110 ÷ 1350 mm | 2500 mm |
| | | — | — | B.050.2.4.S300 | 1360 ÷ 1600 mm | 3000 mm |

50 kg

N.2 Fluid dampers
N.2 Fermi ammortizzati
Fluid



Ball bearings
Cuscinetti a sfera

FLUID

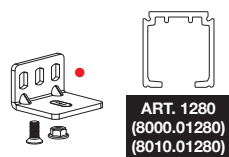
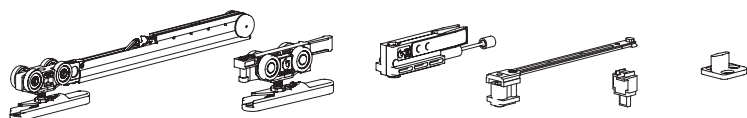

| | | OLD CODE | NEW CODE | | TRACK-BINARIO | |
|----------------|---|----------|----------|-----------------------|-------------------|---------|
| KIT | • | N° 4 | — | K.050.1.4.C | Min. 600 mm | 4x |
| | | — | — | K.050.1.4.S | Min. 600 mm | 4x |
| BLISTER | • | N° 4 | — | B.050.1.4.C150 | 700 ÷ 850 mm | 1500 mm |
| | | N° 5 | — | B.050.1.4.C165 | 860 ÷ 950 mm | 1650 mm |
| | | N° 5 | — | B.050.1.4.C200 | 960 ÷ 1100 mm | 2000 mm |
| | | N° 6 | — | B.050.1.4.C250 | 1110 ÷ 1350 mm | 2500 mm |
| | | N° 7 | — | B.050.1.4.C300 | 1360 ÷ 1600 mm | 3000 mm |
| | | — | — | B.050.1.4.S150 | 700 ÷ 850 mm | 1500 mm |
| | | — | — | B.050.1.4.S165 | 860 ÷ 950 mm | 1650 mm |
| | | — | — | B.050.1.4.S200 | 960 ÷ 1100 mm | 2000 mm |
| | | — | — | B.050.1.4.S250 | 1110 ÷ 1350 mm | 2500 mm |
| | | — | — | B.050.1.4.S300 | 1360 ÷ 1600 mm | 3000 mm |

50 kg

N.1 Fluid damper
N.1 Fermo ammortizzato
Fluid



N.1 Shock absorber
N.1 Fermo a pinza
ammortizzato



Ball bearings
Cuscinetti a sfera

FLUID

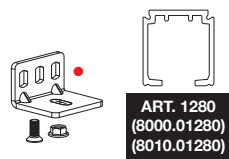
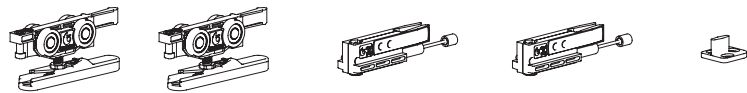

| | | OLD CODE | NEW CODE | | TRACK-BINARIO | |
|----------------|---|----------|----------|-----------------------|-------------------|---------|
| KIT | • | N° 4 | — | K.050.3.4.C | Min. 600 mm | 5x |
| | | — | — | K.050.3.4.S | Min. 600 mm | 5x |
| BLISTER | • | N° 4 | — | B.050.3.4.C150 | 700 ÷ 850 mm | 1500 mm |
| | | N° 5 | — | B.050.3.4.C165 | 860 ÷ 950 mm | 1650 mm |
| | | N° 5 | — | B.050.3.4.C200 | 960 ÷ 1100 mm | 2000 mm |
| | | N° 6 | — | B.050.3.4.C250 | 1110 ÷ 1350 mm | 2500 mm |
| | | N° 7 | — | B.050.3.4.C300 | 1360 ÷ 1600 mm | 3000 mm |
| | | — | — | B.050.3.4.S150 | 700 ÷ 850 mm | 1500 mm |
| | | — | — | B.050.3.4.S165 | 860 ÷ 950 mm | 1650 mm |
| | | — | — | B.050.3.4.S200 | 960 ÷ 1100 mm | 2000 mm |
| | | — | — | B.050.3.4.S250 | 1110 ÷ 1350 mm | 2500 mm |
| | | — | — | B.050.3.4.S300 | 1360 ÷ 1600 mm | 3000 mm |

50 kg

N.2 Shock absorber
N.2 Fermi a pinza
ammortizzati



Ball bearings
Cuscinetti a sfera

FLUID

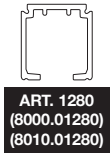
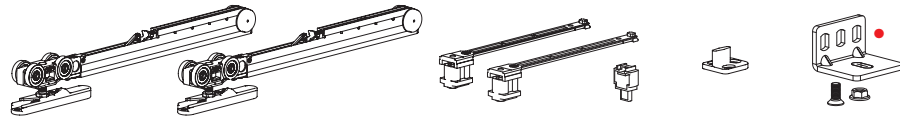

FLUID



80 kg



N.2 Fluid dampers
N.2 Fermi ammortizzati
Fluid



Ball bearings
Cuscinetti a sfera

| | | | OLD CODE | NEW CODE | | TRACK-BINARIO | |
|----------------|---|------|----------|-----------------------|----------------|---------------|----|
| KIT | ● | N° 5 | — | K.080.2.4.C | Min. 740 mm | — | 4x |
| | | — | — | K.080.2.4.S | Min. 740 mm | — | 4x |
| BLISTER | ● | N° 4 | — | B.080.2.4.C150 | 740 ÷ 850 mm | 1500 mm | 4x |
| | | N° 5 | — | B.080.2.4.C165 | 860 ÷ 950 mm | 1650 mm | 4x |
| | | N° 5 | — | B.080.2.4.C200 | 960 ÷ 1100 mm | 2000 mm | 4x |
| | | N° 6 | — | B.080.2.4.C250 | 1110 ÷ 1350 mm | 2500 mm | 4x |
| | | N° 7 | — | B.080.2.4.C300 | 1360 ÷ 1600 mm | 3000 mm | 4x |
| | — | — | — | B.080.2.4.S150 | 700 ÷ 850 mm | 1500 mm | 4x |
| | | — | — | B.080.2.4.S165 | 860 ÷ 950 mm | 1650 mm | 4x |
| | | — | — | B.080.2.4.S200 | 960 ÷ 1100 mm | 2000 mm | 4x |
| | | — | — | B.080.2.4.S250 | 1110 ÷ 1350 mm | 2500 mm | 4x |
| | | — | — | B.080.2.4.S300 | 1360 ÷ 1600 mm | 3000 mm | 4x |

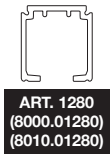
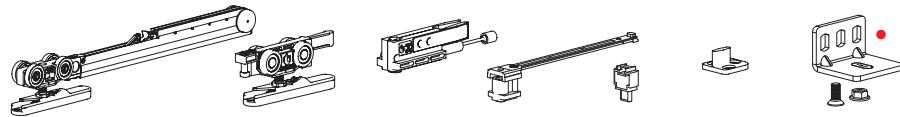

FLUID



80 kg



N.1 Fluid damper
N.1 Fermo ammortizzato
Fluid



N.1 Shock absorber
N.1 Fermo a pinza
ammortizzato



Ball bearings
Cuscinetti a sfera

| | | | OLD CODE | NEW CODE | | TRACK-BINARIO | |
|----------------|---|------|----------|-----------------------|----------------|---------------|----|
| KIT | ● | N° 5 | — | K.080.1.4.C | Min. 600 mm | — | 4x |
| | | — | — | K.080.1.4.S | Min. 600 mm | — | 4x |
| BLISTER | ● | N° 4 | — | B.080.1.4.C150 | 700 ÷ 850 mm | 1500 mm | 4x |
| | | N° 5 | — | B.080.1.4.C165 | 860 ÷ 950 mm | 1650 mm | 4x |
| | | N° 5 | — | B.080.1.4.C200 | 960 ÷ 1100 mm | 2000 mm | 4x |
| | | N° 6 | — | B.080.1.4.C250 | 1110 ÷ 1350 mm | 2500 mm | 4x |
| | | N° 7 | — | B.080.1.4.C300 | 1360 ÷ 1600 mm | 3000 mm | 4x |
| | — | — | — | B.080.1.4.S150 | 700 ÷ 850 mm | 1500 mm | 4x |
| | | — | — | B.080.1.4.S165 | 860 ÷ 950 mm | 1650 mm | 4x |
| | | — | — | B.080.1.4.S200 | 960 ÷ 1100 mm | 2000 mm | 4x |
| | | — | — | B.080.1.4.S250 | 1110 ÷ 1350 mm | 2500 mm | 4x |
| | | — | — | B.080.1.4.S300 | 1360 ÷ 1600 mm | 3000 mm | 4x |

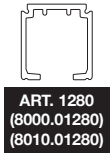
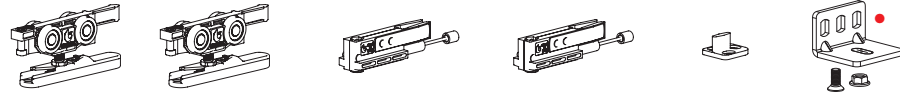

FLUID



80 kg



N.2 Shock absorber
N.2 Fermi a pinza
ammortizzati



Ball bearings
Cuscinetti a sfera

| | | | OLD CODE | NEW CODE | | TRACK-BINARIO | |
|----------------|---|------|----------|-----------------------|----------------|---------------|----|
| KIT | ● | N° 5 | — | K.080.3.4.C | Min. 600 mm | — | 5x |
| | | — | — | K.080.3.4.S | Min. 600 mm | — | 5x |
| BLISTER | ● | N° 4 | — | B.080.3.4.C150 | 700 ÷ 850 mm | 1500 mm | 4x |
| | | N° 5 | — | B.080.3.4.C165 | 860 ÷ 950 mm | 1650 mm | 4x |
| | | N° 5 | — | B.080.3.4.C200 | 960 ÷ 1100 mm | 2000 mm | 4x |
| | | N° 6 | — | B.080.3.4.C250 | 1110 ÷ 1350 mm | 2500 mm | 4x |
| | | N° 7 | — | B.080.3.4.C300 | 1360 ÷ 1600 mm | 3000 mm | 4x |
| | — | — | — | B.080.3.4.S150 | 700 ÷ 850 mm | 1500 mm | 4x |
| | | — | — | B.080.3.4.S165 | 860 ÷ 950 mm | 1650 mm | 4x |
| | | — | — | B.080.3.4.S200 | 960 ÷ 1100 mm | 2000 mm | 4x |
| | | — | — | B.080.3.4.S250 | 1110 ÷ 1350 mm | 2500 mm | 4x |
| | | — | — | B.080.3.4.S300 | 1360 ÷ 1600 mm | 3000 mm | 4x |

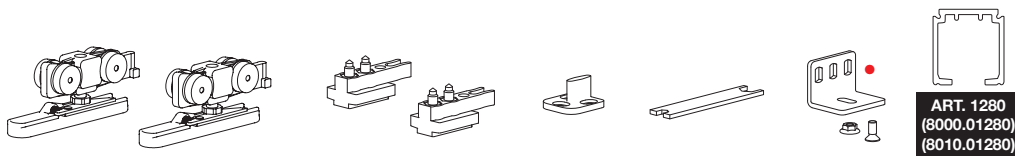

| | L T S | OLD CODE | NEW CODE | MIN | TRACK-BINARIO | | MIN |
|----------------|-----------------|-----------------|----------------|----------------|---------------|----|-----|
| | | | | | | | |
| KIT | ● N° 5 | 80/T/G/AU/CON | K.080.0.4.C | Min. 600 mm | — | — | 5x |
| | — | 80/T/G/AU/SEN | K.080.0.4.S | Min. 600 mm | — | — | 5x |
| BLISTER | ● N° 4 | 80/T/P/AU150CON | B.080.0.4.C150 | 700 ÷ 850 mm | 1500 mm | — | 4x |
| | N° 5 | 80/T/P/AU165CON | B.080.0.4.C165 | 860 ÷ 950 mm | 1650 mm | — | 4x |
| | N° 5 | 80/T/P/AU200CON | B.080.0.4.C200 | 960 ÷ 1100 mm | 2000 mm | — | 4x |
| | N° 6 | 80/T/P/AU250CON | B.080.0.4.C250 | 1110 ÷ 1350 mm | 2500 mm | — | 4x |
| | N° 7 | 80/T/P/AU300CON | B.080.0.4.C300 | 1360 ÷ 1600 mm | 3000 mm | — | 4x |
| | — | 80/T/P/AU150SEN | B.080.0.4.S150 | 700 ÷ 850 mm | 1500 mm | — | 4x |
| | — | 80/T/P/AU165SEN | B.080.0.4.S165 | 860 ÷ 950 mm | 1650 mm | — | 4x |
| | — | 80/T/P/AU200SEN | B.080.0.4.S200 | 960 ÷ 1100 mm | 2000 mm | — | 4x |
| | — | 80/T/P/AU250SEN | B.080.0.4.S250 | 1110 ÷ 1350 mm | 2500 mm | — | 4x |
| — | 80/T/P/AU300SEN | B.080.0.4.S300 | 1360 ÷ 1600 mm | 3000 mm | — | 4x | |



80 kg



N.2 Standard stopper
N.2 Fermi standard



Turned wheels
Ruote tornite

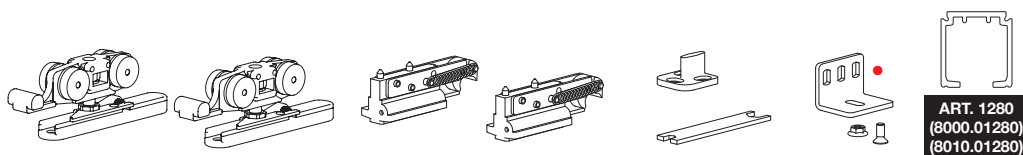

| | L T S | OLD CODE | NEW CODE | MIN | TRACK-BINARIO | | MIN |
|----------------|----------------|----------------|----------------|----------------|---------------|----|-----|
| | | | | | | | |
| KIT | ● N° 5 | 80/TG/AU/C/FAN | K.080.4.4.C | Min. 700 mm | — | — | 5x |
| | — | 80/TG/AU/S/FAN | K.080.4.4.S | Min. 700 mm | — | — | 5x |
| BLISTER | ● N° 4 | 80T/PAU150CFAN | B.080.4.4.C150 | 700 ÷ 850 mm | 1500 mm | — | 4x |
| | N° 5 | 80T/PAU165CFAN | B.080.4.4.C165 | 860 ÷ 950 mm | 1650 mm | — | 4x |
| | N° 5 | 80T/PAU200CFAN | B.080.4.4.C200 | 960 ÷ 1100 mm | 2000 mm | — | 4x |
| | N° 6 | 80T/PAU250CFAN | B.080.4.4.C250 | 1110 ÷ 1350 mm | 2500 mm | — | 4x |
| | N° 7 | 80T/PAU300CFAN | B.080.4.4.C300 | 1360 ÷ 1600 mm | 3000 mm | — | 4x |
| | — | 80T/PAU150SFAN | B.080.4.4.S150 | 700 ÷ 850 mm | 1500 mm | — | 4x |
| | — | 80T/PAU165SFAN | B.080.4.4.S165 | 860 ÷ 950 mm | 1650 mm | — | 4x |
| | — | 80T/PAU200SFAN | B.080.4.4.S200 | 960 ÷ 1100 mm | 2000 mm | — | 4x |
| | — | 80T/PAU250SFAN | B.080.4.4.S250 | 1110 ÷ 1350 mm | 2500 mm | — | 4x |
| — | 80T/PAU300SFAN | B.080.4.4.S300 | 1360 ÷ 1600 mm | 3000 mm | — | 4x | |



80 kg



N.2 Hydraulic stopper
N.2 Fermi idraulici



Suitable for naval sector
Adatto per settore navale



Turned wheels
Ruote tornite

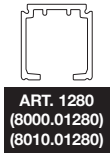
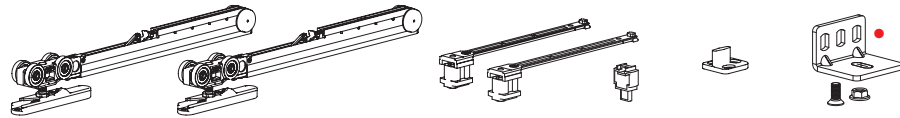

ART. 1280
(8000.01280)
(8010.01280)

FLUID



120 kg



N.2 Fluid dampers
N.2 Fermi ammortizzati
Fluid



Ball bearings
Cuscinetti a sfera

| | | | OLD CODE | NEW CODE | | TRACK-BINARIO | |
|----------------|---|------|----------|-----------------------|----------------|-------------------|----|
| KIT | ● | N° 6 | — | K.120.2.4.C | Min. 740 mm | — | 4x |
| | | — | — | K.120.2.4.S | Min. 740 mm | — | 4x |
| BLISTER | ● | N° 4 | — | B.120.2.4.C150 | 740 ÷ 850 mm | 1500 mm | 4x |
| | | N° 5 | — | B.120.2.4.C165 | 860 ÷ 950 mm | 1650 mm | 4x |
| | | N° 5 | — | B.120.2.4.C200 | 960 ÷ 1100 mm | 2000 mm | 4x |
| | | N° 6 | — | B.120.2.4.C250 | 1110 ÷ 1350 mm | 2500 mm | 4x |
| | | N° 7 | — | B.120.2.4.C300 | 1360 ÷ 1600 mm | 3000 mm | 4x |
| | | — | — | B.120.2.4.S150 | 700 ÷ 850 mm | 1500 mm | 4x |
| | | — | — | B.120.2.4.S165 | 860 ÷ 950 mm | 1650 mm | 4x |
| | | — | — | B.120.2.4.S200 | 960 ÷ 1100 mm | 2000 mm | 4x |
| | | — | — | B.120.2.4.S250 | 1110 ÷ 1350 mm | 2500 mm | 4x |
| | | — | — | B.120.2.4.S300 | 1360 ÷ 1600 mm | 3000 mm | 4x |

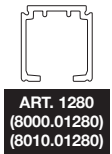
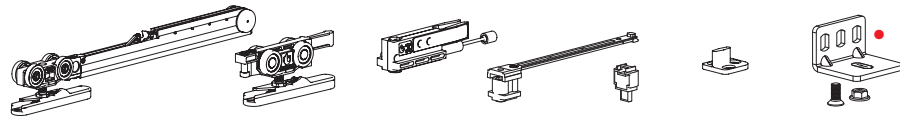

ART. 1280
(8000.01280)
(8010.01280)

FLUID



120 kg



N.1 Fluid damper
N.1 Fermo ammortizzato
Fluid



N.1 Shock absorber
N.1 Fermo a pinza
ammortizzato



Ball bearings
Cuscinetti a sfera

| | | | OLD CODE | NEW CODE | | TRACK-BINARIO | |
|----------------|---|------|----------|-----------------------|----------------|-------------------|----|
| KIT | ● | N° 6 | — | K.120.1.4.C | Min. 600 mm | — | 4x |
| | | — | — | K.120.1.4.S | Min. 600 mm | — | 4x |
| BLISTER | ● | N° 4 | — | B.120.1.4.C150 | 700 ÷ 850 mm | 1500 mm | 4x |
| | | N° 5 | — | B.120.1.4.C165 | 860 ÷ 950 mm | 1650 mm | 4x |
| | | N° 5 | — | B.120.1.4.C200 | 960 ÷ 1100 mm | 2000 mm | 4x |
| | | N° 6 | — | B.120.1.4.C250 | 1110 ÷ 1350 mm | 2500 mm | 4x |
| | | N° 7 | — | B.120.1.4.C300 | 1360 ÷ 1600 mm | 3000 mm | 4x |
| | | — | — | B.120.1.4.S150 | 700 ÷ 850 mm | 1500 mm | 4x |
| | | — | — | B.120.1.4.S165 | 860 ÷ 950 mm | 1650 mm | 4x |
| | | — | — | B.120.1.4.S200 | 960 ÷ 1100 mm | 2000 mm | 4x |
| | | — | — | B.120.1.4.S250 | 1110 ÷ 1350 mm | 2500 mm | 4x |
| | | — | — | B.120.1.4.S300 | 1360 ÷ 1600 mm | 3000 mm | 4x |

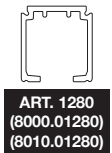
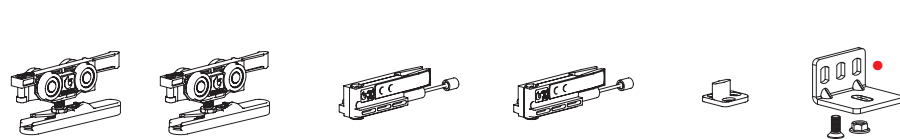

ART. 1280
(8000.01280)
(8010.01280)

FLUID



120 kg



N.2 Shock absorber
N.2 Fermi a pinza
ammortizzati



Ball bearings
Cuscinetti a sfera

| | | | OLD CODE | NEW CODE | | TRACK-BINARIO | |
|----------------|---|------|----------|-----------------------|----------------|-------------------|----|
| KIT | ● | N° 6 | — | K.120.3.4.C | Min. 600 mm | — | 5x |
| | | — | — | K.120.3.4.S | Min. 600 mm | — | 5x |
| BLISTER | ● | N° 4 | — | B.120.3.4.C150 | 700 ÷ 850 mm | 1500 mm | 4x |
| | | N° 5 | — | B.120.3.4.C165 | 860 ÷ 950 mm | 1650 mm | 4x |
| | | N° 5 | — | B.120.3.4.C200 | 960 ÷ 1100 mm | 2000 mm | 4x |
| | | N° 6 | — | B.120.3.4.C250 | 1110 ÷ 1350 mm | 2500 mm | 4x |
| | | N° 7 | — | B.120.3.4.C300 | 1360 ÷ 1600 mm | 3000 mm | 4x |
| | | — | — | B.120.3.4.S150 | 700 ÷ 850 mm | 1500 mm | 4x |
| | | — | — | B.120.3.4.S165 | 860 ÷ 950 mm | 1650 mm | 4x |
| | | — | — | B.120.3.4.S200 | 960 ÷ 1100 mm | 2000 mm | 4x |
| | | — | — | B.120.3.4.S250 | 1110 ÷ 1350 mm | 2500 mm | 4x |
| | | — | — | B.120.3.4.S300 | 1360 ÷ 1600 mm | 3000 mm | 4x |

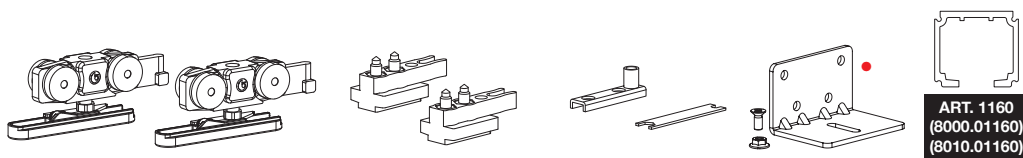

| KIT | L | N° | OLD CODE | NEW CODE | MIN | TRACK-BINARIO | |
|---------|---|--------|-----------------|----------------|----------------|---------------|-----|
| | | | | | | MIN | MIN |
| ● | L | N° 6 | 160/T/G/AU/CON | K.160.0.4.C | Min. 700 mm | — | 5x |
| | | — | 160/T/G/AU/SEN | K.160.0.4.S | Min. 700 mm | — | 5x |
| BLISTER | L | ● N° 6 | 160/T/P/AU200CO | B.160.0.4.C200 | 960 ÷ 1100 mm | 2000 mm | 4x |
| | | N° 7 | 160/T/P/AU250CO | B.160.0.4.C250 | 1110 ÷ 1350 mm | 2500 mm | 4x |
| | | N° 8 | 160/T/P/AU300CO | B.160.0.4.C300 | 1360 ÷ 1600 mm | 3000 mm | 4x |
| | | — | 160/T/P/AU200SE | B.160.0.4.S200 | 960 ÷ 1100 mm | 2000 mm | 4x |
| | | — | 160/T/P/AU250SE | B.160.0.4.S250 | 1110 ÷ 1350 mm | 2500 mm | 4x |
| | | — | 160/T/P/AU300SE | B.160.0.4.S300 | 1360 ÷ 1600 mm | 3000 mm | 4x |

160 kg

N.2 Standard stoppers
N.2 Fermi standard

Turned wheels
Ruote tornite

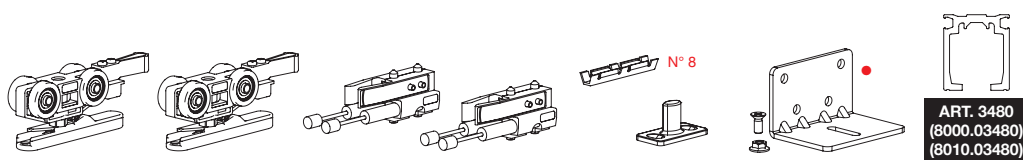

| KIT | L | N° | OLD CODE | NEW CODE | MIN | TRACK-BINARIO | |
|---------|---|--------|----------|----------------|----------------|---------------|-----|
| | | | | | | MIN | MIN |
| ● | L | N° 6 | — | K.180.3.4.C | Min. 700 mm | — | 5x |
| | | — | — | K.180.3.4.S | Min. 700 mm | — | 5x |
| BLISTER | L | ● N° 6 | — | B.180.3.4.C200 | 960 ÷ 1100 mm | 2000 mm | 4x |
| | | N° 7 | — | B.180.3.4.C250 | 1110 ÷ 1350 mm | 2500 mm | 4x |
| | | N° 8 | — | B.180.3.4.C300 | 1360 ÷ 1600 mm | 3000 mm | 4x |
| | | — | — | B.180.3.4.S200 | 960 ÷ 1100 mm | 2000 mm | 4x |
| | | — | — | B.180.3.4.S250 | 1110 ÷ 1350 mm | 2500 mm | 4x |
| | | — | — | B.180.3.4.S300 | 1360 ÷ 1600 mm | 3000 mm | 4x |

180 kg

N.2 Shock absorber
N.2 Fermi a pinza ammortizzati

Ball bearings
Cuscinetti a sfera

FLUID

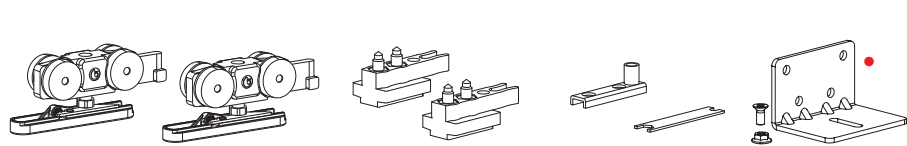

ART. 201
(8000.0201)
(8010.0201)



240 kg



N.2 Standard stoppers
N.2 Fermi standard



Turned wheels
Ruote tornite

| | | | OLD CODE | NEW CODE | | TRACK-BINARIO | |
|----------------|---|-----------------|-----------------|----------------|----------------|-------------------|----|
| KIT | ● | N° 7 | 240/T/G/AU/CON | K.240.0.4.C | Min. 700 mm | — | 5x |
| | | — | 240/T/G/AU/SEN | K.240.0.4.S | Min. 700 mm | — | 5x |
| BLISTER | ● | N° 6 | 240/T/P/AU200CO | B.240.0.4.C200 | 960 ÷ 1100 mm | 2000 mm | 4x |
| | | N° 7 | 240/T/P/AU250CO | B.240.0.4.C250 | 1110 ÷ 1350 mm | 2500 mm | 4x |
| | | N° 8 | 240/T/P/AU300CO | B.240.0.4.C300 | 1360 ÷ 1600 mm | 3000 mm | 4x |
| | — | 240/T/P/AU200SE | B.240.0.4.S200 | 960 ÷ 1100 mm | 2000 mm | 4x | |
| | — | 240/T/P/AU250SE | B.240.0.4.S250 | 1110 ÷ 1350 mm | 2500 mm | 4x | |
| | — | 240/T/P/AU300SE | B.240.0.4.S300 | 1360 ÷ 1600 mm | 3000 mm | 4x | |

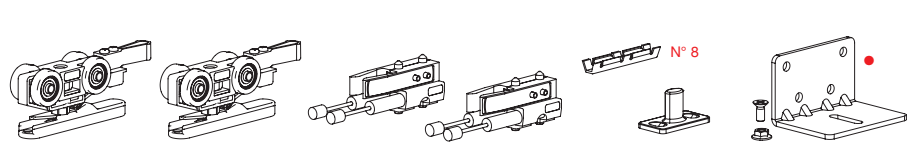

ART. 3480
(8000.03480)
(8010.03480)

250 kg



N.2 Shock absorber
N.2 Fermi a pinza
ammortizzati



Ball bearings
Cuscinetti a sfera

| | | | OLD CODE | NEW CODE | | TRACK-BINARIO | |
|----------------|---|------|----------------|----------------|----------------|-------------------|----|
| KIT | ● | N° 7 | — | K.250.3.4.C | Min. 700 mm | — | 5x |
| | | — | — | K.250.3.4.S | Min. 700 mm | — | 5x |
| BLISTER | ● | N° 6 | — | B.250.3.4.C200 | 960 ÷ 1100 mm | 2000 mm | 4x |
| | | N° 7 | — | B.250.3.4.C250 | 1110 ÷ 1350 mm | 2500 mm | 4x |
| | | N° 8 | — | B.250.3.4.C300 | 1360 ÷ 1600 mm | 3000 mm | 4x |
| | — | — | B.250.3.4.S200 | 960 ÷ 1100 mm | 2000 mm | 4x | |
| | — | — | B.250.3.4.S250 | 1110 ÷ 1350 mm | 2500 mm | 4x | |
| | — | — | B.250.3.4.S300 | 1360 ÷ 1600 mm | 3000 mm | 4x | |

N.2 Soft damper stoppers
N.2 Fermi ammortizzati

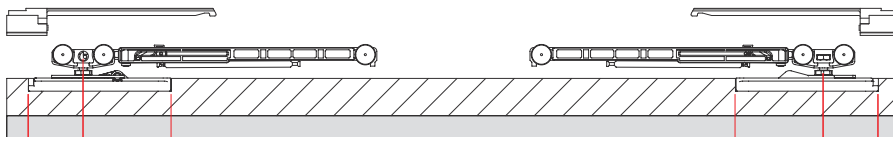

N.1 Soft damper stopper + N.1 Standard stopper
N.1 Fermo ammortizzato + N.1 Fermo standard

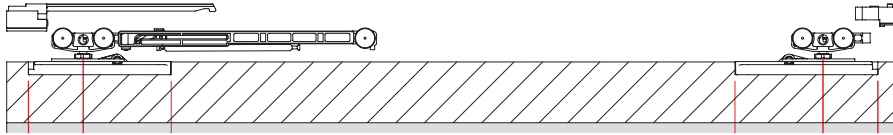

N.2 Standard stoppers
N.2 Fermi standard

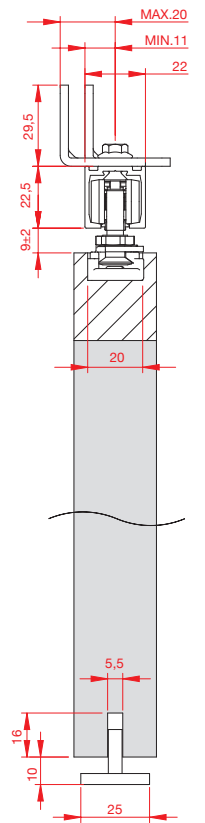
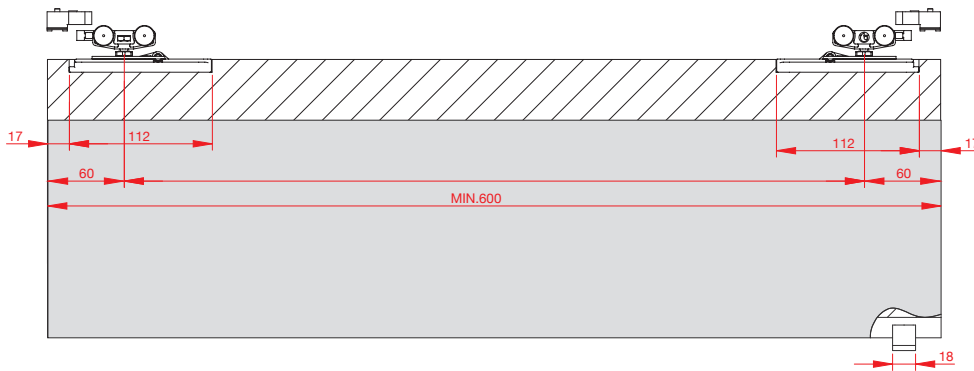

N.2 Fluid dampers
N.2 Fermi ammortizzati Fluid

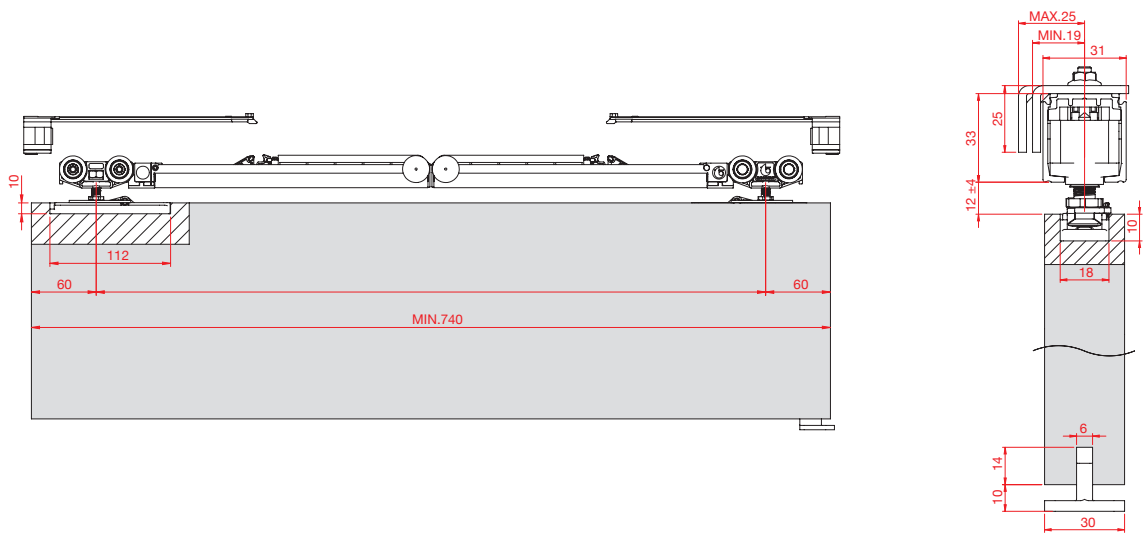

N.1 Fluid damper + N.1 Shock absorber
N.1 Fermo ammortizzato Fluid + N.1 Fermo a pinza ammortizzato

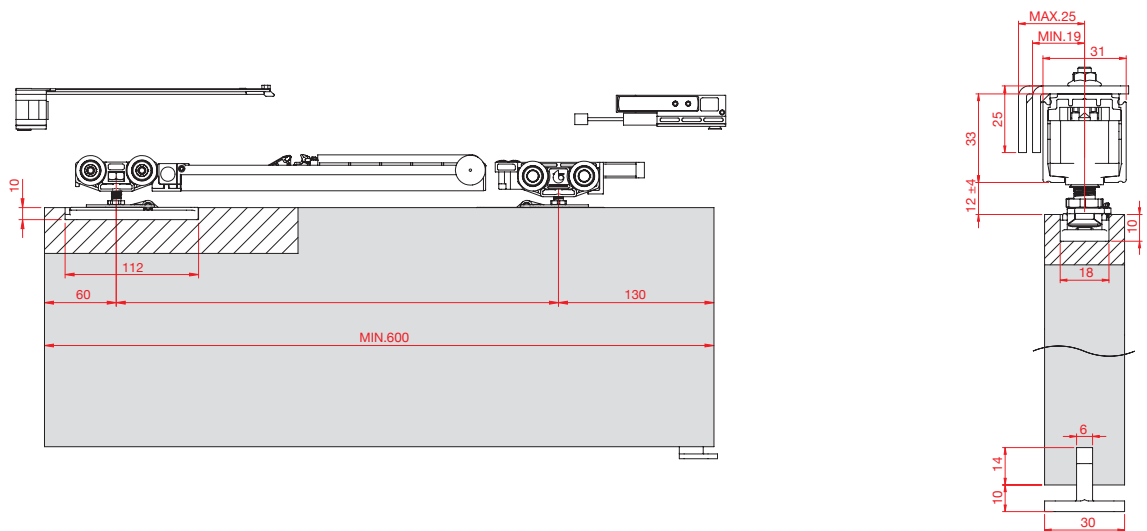

N.2 Shock absorber
N.2 Fermi a pinza ammortizzati

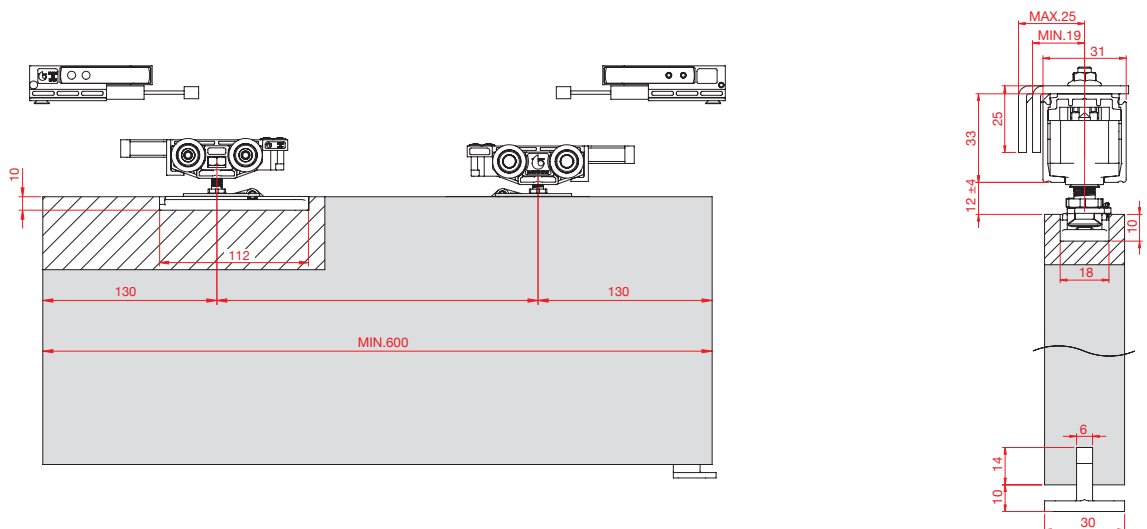

FLUID



50 kg
80 kg
120 kg

N.2 Standard stoppers
N.2 Fermi standard

80 kg

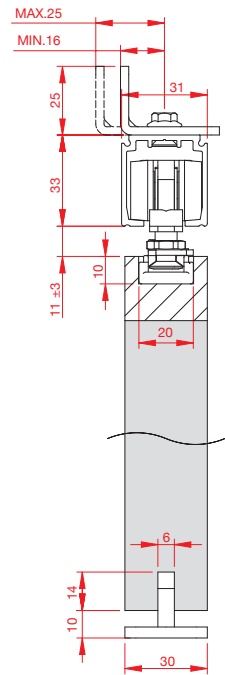
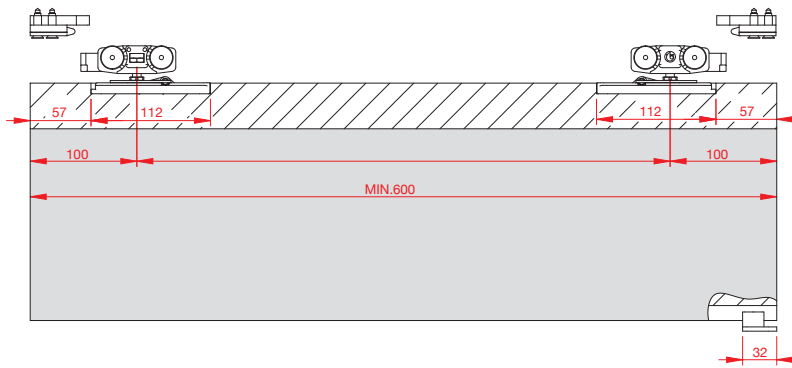

N.2 Hydraulic stopper
N.2 Fermi idraulici

80 kg

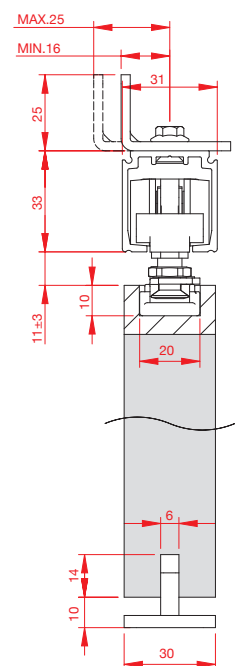
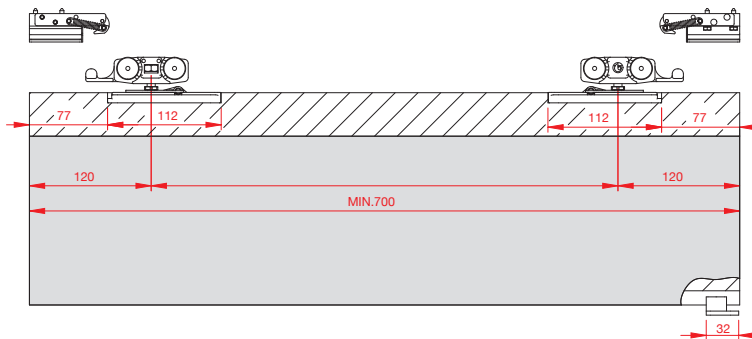

N.2 Standard stoppers
N.2 Fermi standard

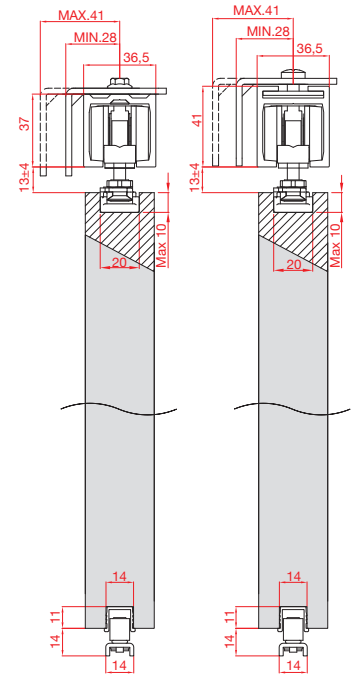
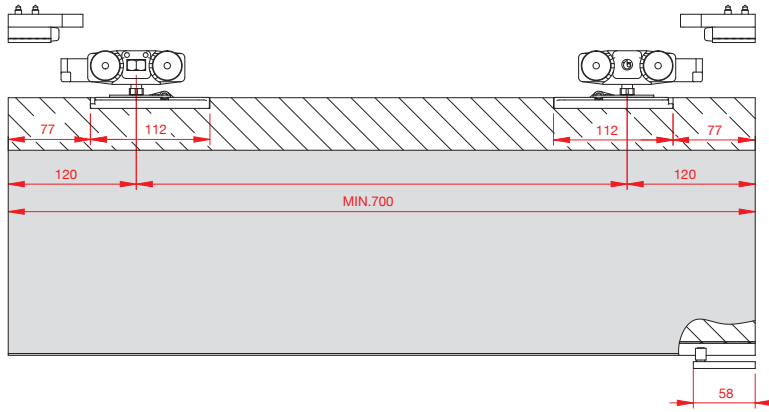

160 kg



N.2 Shock absorber
N.2 Fermi a pinza ammortizzati

FLUID

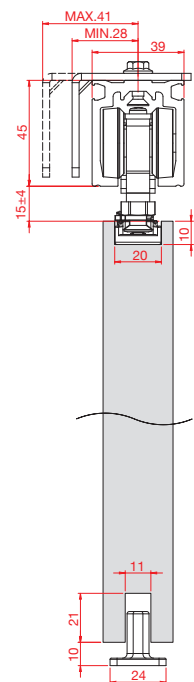
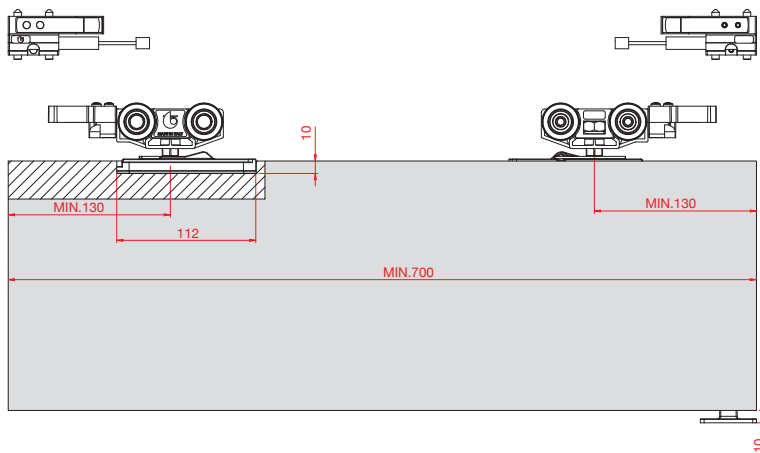
180 kg



N.2 Standard stoppers
N.2 Fermi standard

240 kg

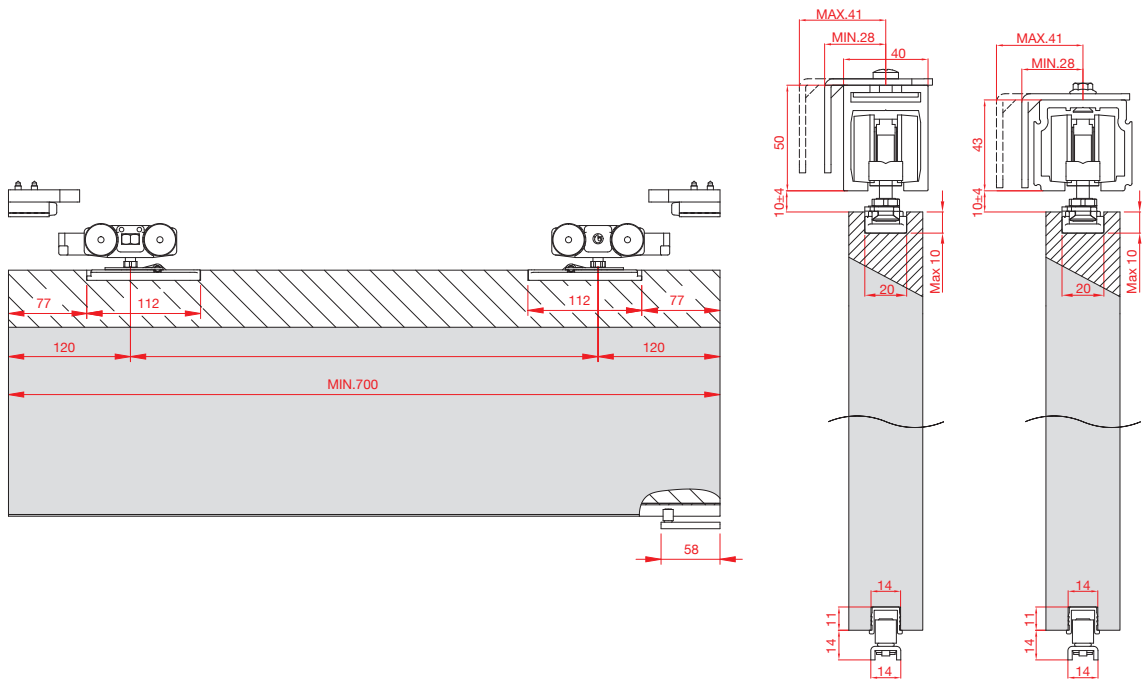

N.2 Shock absorber
N.2 Fermi a pinza ammortizzati

250 kg

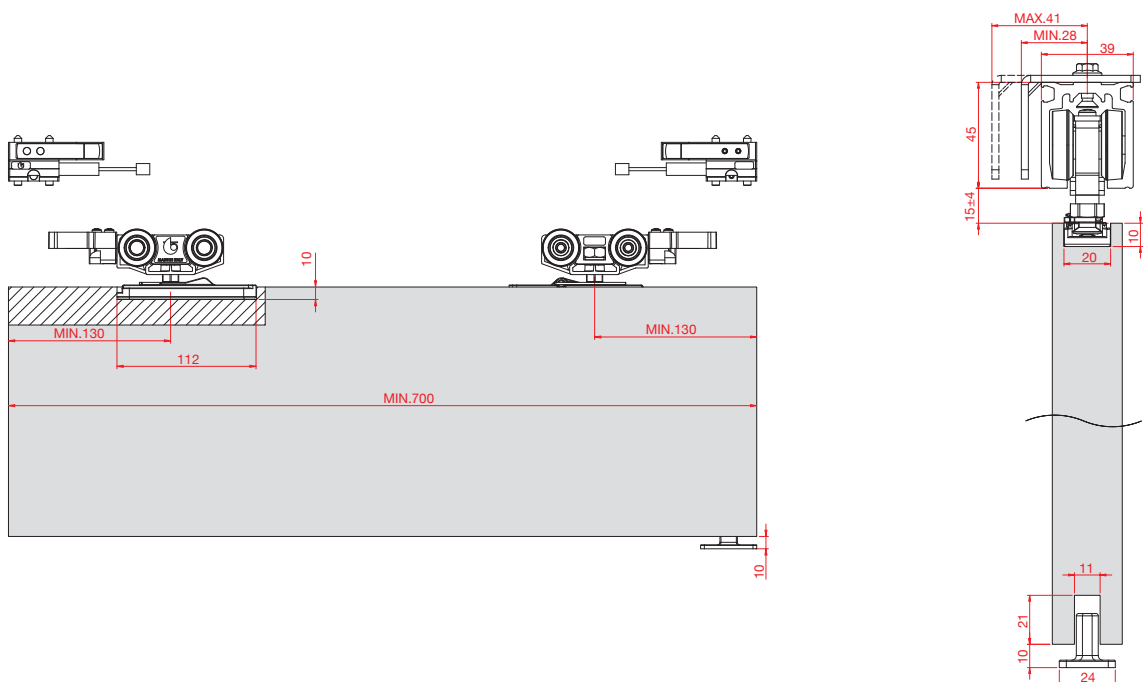

FLUID



Evolution

The invisible bracket sliding system
Sistema scorrevole con staffa invisibile





PATENTED

The classic bracket has evolved, becoming invisible

In times of difficult economic recovery, we often think about optimizing new solutions that well match the concepts of **simplicity and cost effectiveness**. So it happens that from a simple concept something extraordinary arises. Something extremely original, capable of rewriting all the rules.

Terno Scorrevoli, increasingly engaged in the development of products that can be functional and aesthetically pleasant, has created **Evolution**, a sliding system for internal wooden, which stands out from classic bracket systems.

Compared to traditional door bracket systems, **Evolution revolutionizes the sliding unit concept in several ways.**

La staffa tradizionale si evolve e diventa invisibile

In tempi di difficile ripresa economica si pensa sempre ad ottimizzare nuove soluzioni che sposino bene i concetti di **semplicità ed economicità**. Capita poi che proprio da un concetto semplice nasca qualcosa di straordinario. Qualcosa di talmente innovativo da riscrivere tutte le regole.

Terno Scorrevoli, sempre più attenta allo sviluppo di prodotti che possano essere funzionali ed esteticamente poco invasivi, ha creato **Evolution**, un sistema scorrevole per porte in legno, nato per distinguersi dal concetto tradizionale di staffa.

Rispetto ai tradizionali sistemi per porte a staffa, **Evolution rivoluziona il concetto di scorrevole in molti modi.**

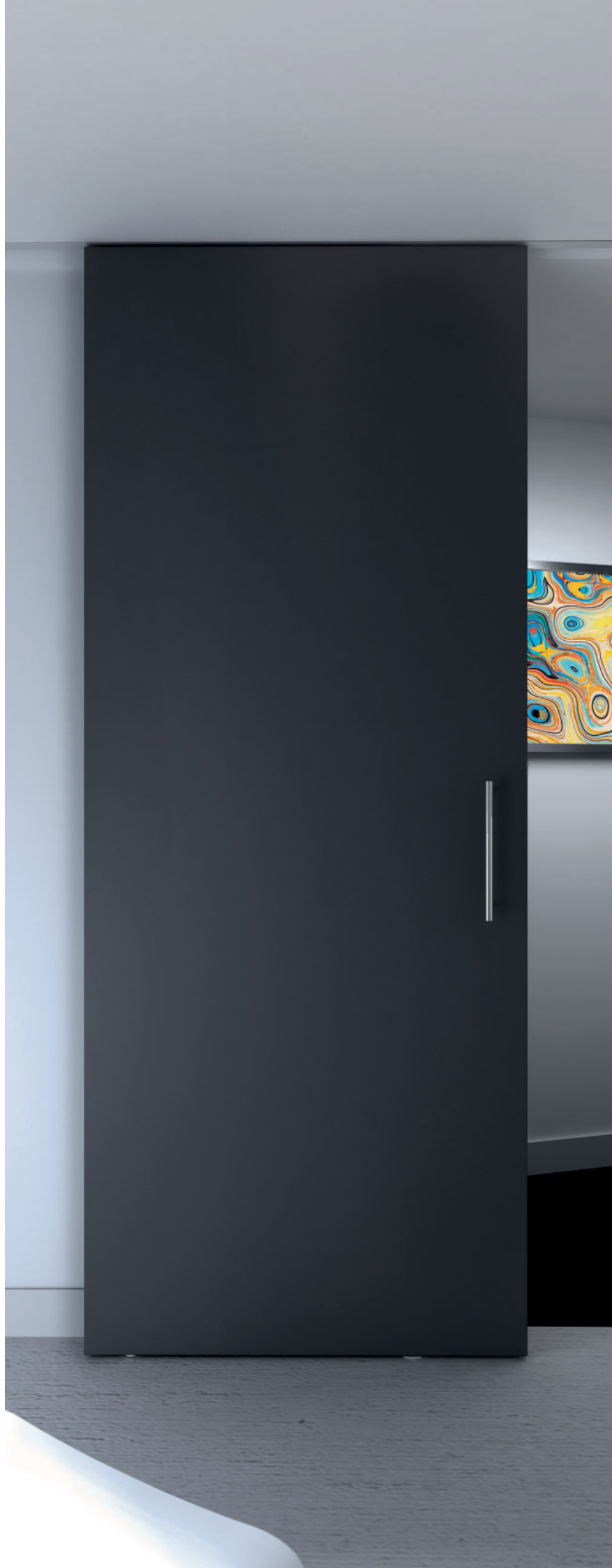

Fully concealed recessed fitting

One of the main features of this system is the lack of any visual impact. In fact, the system is designed to be completely concealed, including the option of a recessed ceiling rail.

A scomparsa totale

Una delle caratteristiche più importanti è proprio quella di essere un sistema in grado non avere alcun impatto visivo.

Il sistema è infatti progettato per scomparire completamente offrendo anche la possibilità di realizzare un'installazione con binario incassato a soffitto.

Reduced upper/lower gap

Its peculiar structure allows the side positioning of the fastening and adjustment systems; in this way, there is only a 2 mm upper gap between the guide and the door and a 6 mm gap between the floor and the door.

Luce superiore ed inferiore ridotta

La sua particolare costruzione fa sì che, sia il sistema di fissaggio, sia il sistema di regolazione, siano posizionati lateralmente; in questo modo si ottiene una luce superiore fra binario e porta di soli 2 mm e una luce tra porta e pavimento di 6 mm.

Noiseless with anti-bounce system

The bracket includes an innovative anti-bounce system which, together with the air shock absorbers, allows a stable and soft stop of the door.

Silenzioso, con antisobbalzo

La staffa include un innovativo sistema antisobbalzo che, in combinazione con i fermi ammortizzati ad aria, rendono l'arresto della porta stabile e morbido.

Evolution is a truly special patented system: its features make it interesting in every sense. Anyone who is looking for an enhanced door sliding system, will be thrilled about this recessed sliding system.

Evolution è un sistema brevettato davvero speciale: le sue caratteristiche lo rendono interessante sotto ogni punto di vista. Chiunque sia alla ricerca del perfezionamento dello scorrevole per porta non potrà fare a meno di essere entusiasta di questo sistema scorrevole a scomparsa.

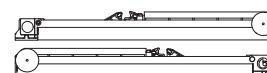

N.2 FLUID DAMPERS
N.2 FERMI AMMORTIZZATI FLUID



50 kg

NEW



Min. 740 mm

PAG. 11



80 kg

NEW



Min. 740 mm

PAG. 12



120 kg

NEW







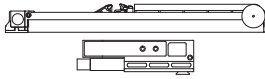











Min. 740 mm

PAG. 13



N.1 FLUID DAMPER + N.1 SHOCK ABSORBER
N.1 FERMO AMMORTIZZATO FLUID + N.1 FERMO A PINZA
AMMORTIZZATO

N.2 SHOCK ABSORBERS
N.2 FERMI A PINZA
AMMORTIZZATI

| | |
|--|---|
|    Min. 600 mm PAG. 11 |    Min. 600 mm PAG. 11 |
|    Min. 600 mm PAG. 12 |    Min. 600 mm PAG. 12 |
|    Min. 600 mm PAG. 13 |    Min. 600 mm PAG. 13 |

Evolution

The invisible bracket sliding system
Sistema scorrevole con staffa invisibile

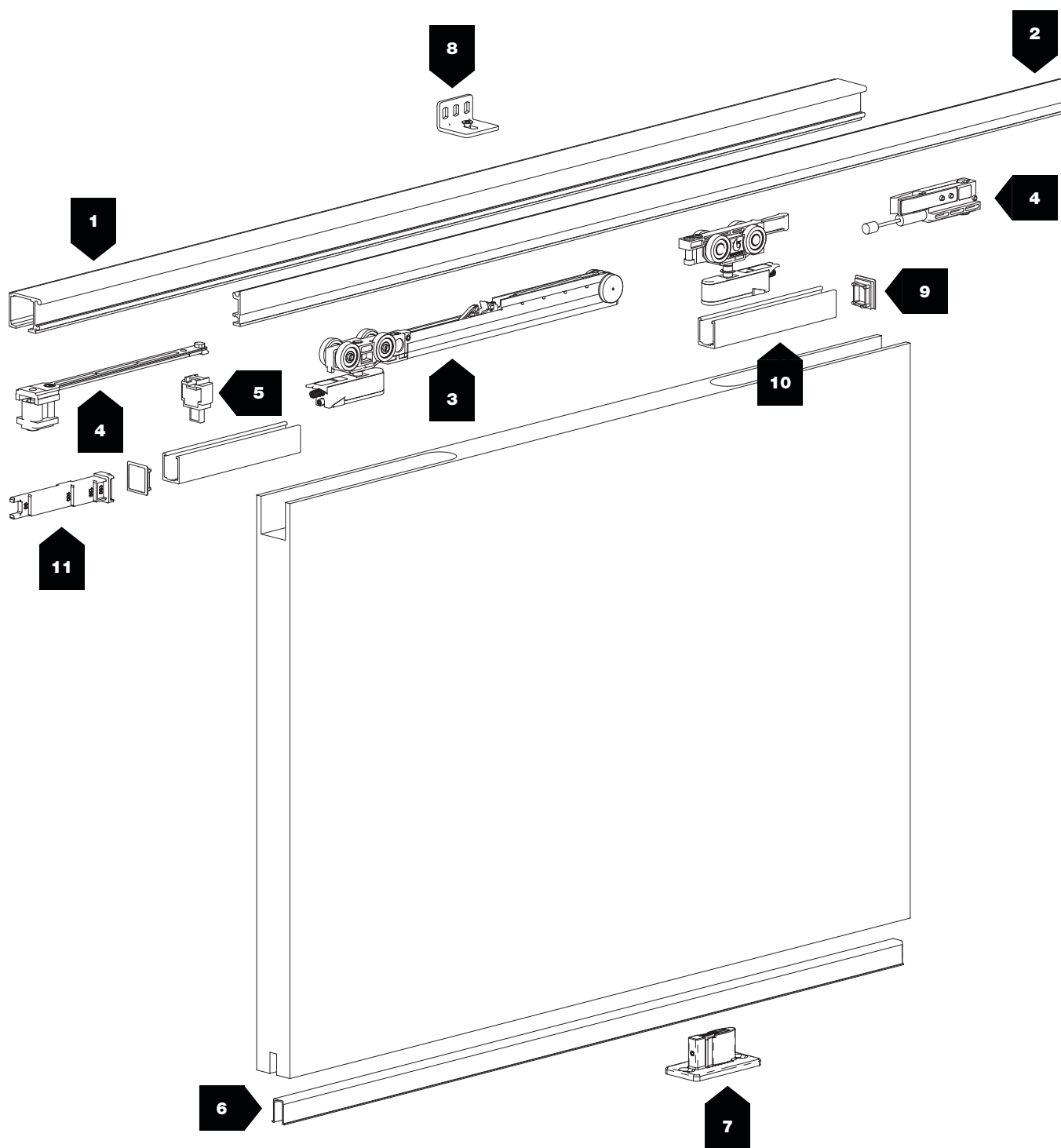







600 ÷ 1500 mm

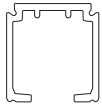

50 ÷ 120 kg

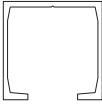
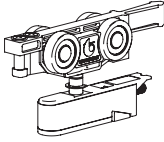
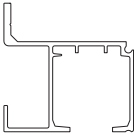
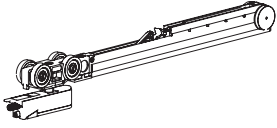
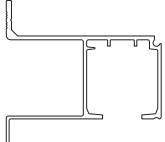
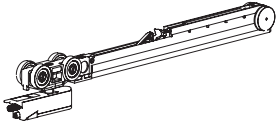

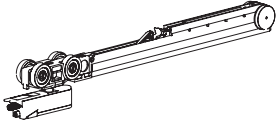

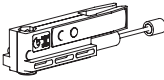

6 ÷ 15 mm

| N° | Barcode | | kg | | N° | Barcode | | kg | | |
|----|--------------------------------------|---|----|---------------|----|--------------------------------------|---|--------|---------------|--------------|
| 1 | 1280 8 00 0.01280 8 01 0.01280 |  | - | STANDARD | 2 | 1720 8 00 0.01720 8 01 0.01720 |  | - | OPTIONAL + | |
| | 1080 8 00 0.01080 8 01 0.01080 |  | - | OPTIONAL + | | 3368 |  | 50÷120 | | FLUID NEW |
| | 1359 8 00 0.01359 8 01 0.01359 |  | - | OPTIONAL + | | 3362/050 |  | 50 | | FLUID NEW |
| | 1559 8 00 0.01559 8 01 0.01559 |  | - | OPTIONAL + | | 3362/080 |  | 80 | | FLUID NEW |
| | 1700 8 00 0.01700 8 01 0.01700 |  | - | OPTIONAL + | | 3362/120 |  | 120 | | FLUID NEW |
| 2 | 1710 8 00 0.01710 8 01 0.01710 |  | - | OPTIONAL + | 4 | 3355/050 |  | 50 | FLUID NEW | |

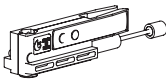
Evolution

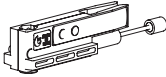
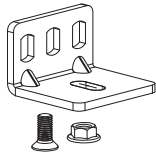
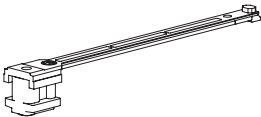
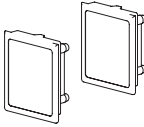
The invisible bracket sliding system
Sistema scorrevole con staffa invisibile

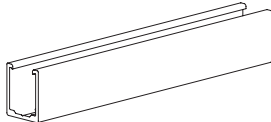
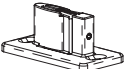
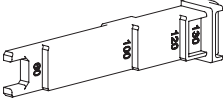
| N° | | | kg | | N° | | | kg | |
|----|---------------------|---|--------|----------------------------|----|---------|---|--------|--|
| 4 | 3355/080 |  | 80 | FLUID NEW | 7 | 409 |  | — | |
| | 3355/120 |  | 120 | FLUID NEW | 8 | 127/D/V |  | 50÷120 | |
| | 3354 |  | 50÷120 | FLUID NEW | 9 | 2354/A |  | 50÷120 | |
| 5 | 3347 | — | | 2354/N | | | | | |
| 6 | 121 8 23 0.00121 |  | 50÷120 | OPTIONAL + | 10 | 2351 |  | 50 | |
| 7 | 90 |  | 50÷120 | | | 2356 | | 80÷120 | |
| | | | | | 11 | 2364 |  | — | |

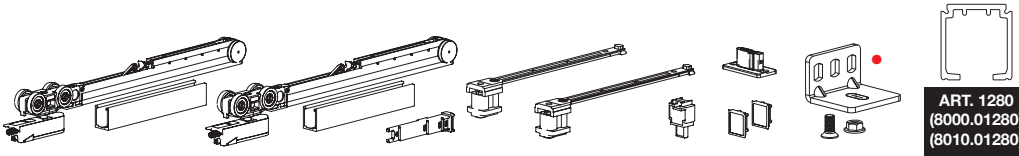

| | | OLD CODE | NEW CODE | | TRACK-BINARIO | |
|----------------|---|----------|-----------------------|-----------------------|-------------------|---------|
| KIT | • | N° 4 | — | K.050.2.3.C | Min. 740 mm | 4x |
| | — | — | — | K.050.2.3.S | Min. 740 mm | 4x |
| BLISTER | • | N° 4 | — | B.050.2.3.C150 | 740 ÷ 850 mm | 1500 mm |
| | | N° 5 | — | B.050.2.3.C165 | 860 ÷ 950 mm | 1650 mm |
| | | N° 5 | — | B.050.2.3.C200 | 960 ÷ 1100 mm | 2000 mm |
| | | N° 6 | — | B.050.2.3.C250 | 1110 ÷ 1350 mm | 2500 mm |
| | | N° 7 | — | B.050.2.3.C300 | 1360 ÷ 1600 mm | 3000 mm |
| | — | — | — | B.050.2.3.S150 | 700 ÷ 850 mm | 1500 mm |
| | — | — | — | B.050.2.3.S165 | 860 ÷ 950 mm | 1650 mm |
| | — | — | — | B.050.2.3.S200 | 960 ÷ 1100 mm | 2000 mm |
| | — | — | — | B.050.2.3.S250 | 1110 ÷ 1350 mm | 2500 mm |
| — | — | — | B.050.2.3.S300 | 1360 ÷ 1600 mm | 3000 mm | |

50 kg

N.2 Fluid dampers
N.2 Fermi ammortizzati
Fluid



Ball bearings
Cuscinetti a sfera

FLUID

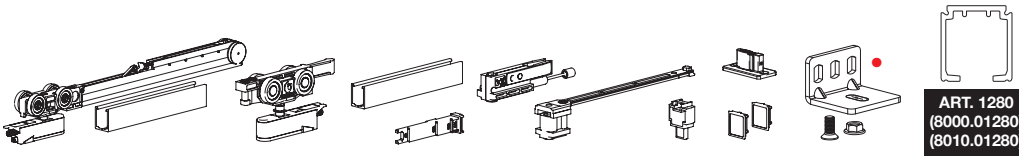

| | | OLD CODE | NEW CODE | | TRACK-BINARIO | |
|----------------|---|----------|-----------------------|-----------------------|-------------------|---------|
| KIT | • | N° 4 | — | K.050.1.3.C | Min. 600 mm | 4x |
| | — | — | — | K.050.1.3.S | Min. 600 mm | 4x |
| BLISTER | • | N° 4 | — | B.050.1.3.C150 | 700 ÷ 850 mm | 1500 mm |
| | | N° 5 | — | B.050.1.3.C165 | 860 ÷ 950 mm | 1650 mm |
| | | N° 5 | — | B.050.1.3.C200 | 960 ÷ 1100 mm | 2000 mm |
| | | N° 6 | — | B.050.1.3.C250 | 1110 ÷ 1350 mm | 2500 mm |
| | | N° 7 | — | B.050.1.3.C300 | 1360 ÷ 1600 mm | 3000 mm |
| | — | — | — | B.050.1.3.S150 | 700 ÷ 850 mm | 1500 mm |
| | — | — | — | B.050.1.3.S165 | 860 ÷ 950 mm | 1650 mm |
| | — | — | — | B.050.1.3.S200 | 960 ÷ 1100 mm | 2000 mm |
| | — | — | — | B.050.1.3.S250 | 1110 ÷ 1350 mm | 2500 mm |
| — | — | — | B.050.1.3.S300 | 1360 ÷ 1600 mm | 3000 mm | |

50 kg

N.1 Fluid damper
N.1 Fermo ammortizzato
Fluid



N.1 Shock absorber
N.1 Fermo a pinza
ammortizzato



Ball bearings
Cuscinetti a sfera

FLUID

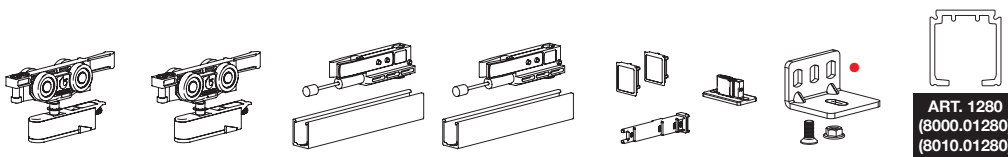

| | | OLD CODE | NEW CODE | | TRACK-BINARIO | |
|----------------|---|----------|-----------------------|-----------------------|-------------------|---------|
| KIT | • | N° 4 | — | K.050.3.3.C | Min. 600 mm | 5x |
| | — | — | — | K.050.3.3.S | Min. 600 mm | 5x |
| BLISTER | • | N° 4 | — | B.050.3.3.C150 | 700 ÷ 850 mm | 1500 mm |
| | | N° 5 | — | B.050.3.3.C165 | 860 ÷ 950 mm | 1650 mm |
| | | N° 5 | — | B.050.3.3.C200 | 960 ÷ 1100 mm | 2000 mm |
| | | N° 6 | — | B.050.3.3.C250 | 1110 ÷ 1350 mm | 2500 mm |
| | | N° 7 | — | B.050.3.3.C300 | 1360 ÷ 1600 mm | 3000 mm |
| | — | — | — | B.050.3.3.S150 | 700 ÷ 850 mm | 1500 mm |
| | — | — | — | B.050.3.3.S165 | 860 ÷ 950 mm | 1650 mm |
| | — | — | — | B.050.3.3.S200 | 960 ÷ 1100 mm | 2000 mm |
| | — | — | — | B.050.3.3.S250 | 1110 ÷ 1350 mm | 2500 mm |
| — | — | — | B.050.3.3.S300 | 1360 ÷ 1600 mm | 3000 mm | |

50 kg

N.2 Shock absorber
N.2 Fermi a pinza
ammortizzati



Ball bearings
Cuscinetti a sfera

FLUID

Evolution

The invisible bracket sliding system
Sistema scorrevole con staffa invisibile

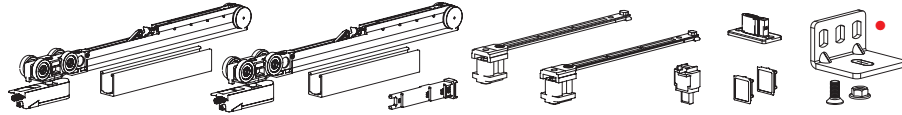

ART. 1280
(8000.01280)
(8010.01280)

FLUID

80 kg

N.2 Fluid dampers
N.2 Fermi ammortizzati Fluid

Ball bearings
Cuscinetti a sfera

| | | OLD CODE | NEW CODE | | TRACK-BINARIO | |
|----------------|---|----------|----------|-----------------------|----------------|----|
| KIT | • | N° 5 | — | K.080.2.3.C | Min. 740 mm | 4x |
| | | — | — | K.080.2.3.S | Min. 740 mm | 4x |
| BLISTER | • | N° 4 | — | B.080.2.3.C150 | 740 ÷ 850 mm | 4x |
| | | N° 5 | — | B.080.2.3.C165 | 860 ÷ 950 mm | 4x |
| | | N° 5 | — | B.080.2.3.C200 | 960 ÷ 1100 mm | 4x |
| | | N° 6 | — | B.080.2.3.C250 | 1110 ÷ 1350 mm | 4x |
| | | N° 7 | — | B.080.2.3.C300 | 1360 ÷ 1600 mm | 4x |
| | | — | — | B.080.2.3.S150 | 700 ÷ 850 mm | 4x |
| | | — | — | B.080.2.3.S165 | 860 ÷ 950 mm | 4x |
| | | — | — | B.080.2.3.S200 | 960 ÷ 1100 mm | 4x |
| | | — | — | B.080.2.3.S250 | 1110 ÷ 1350 mm | 4x |
| | | — | — | B.080.2.3.S300 | 1360 ÷ 1600 mm | 4x |

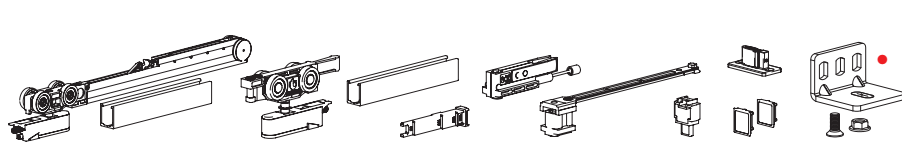

ART. 1280
(8000.01280)
(8010.01280)

FLUID

80 kg

N.1 Fluid damper
N.1 Fermo ammortizzato Fluid

N.1 Shock absorber
N.1 Fermo a pinza ammortizzato

Ball bearings
Cuscinetti a sfera

| | | OLD CODE | NEW CODE | | TRACK-BINARIO | |
|----------------|---|----------|----------|-----------------------|----------------|----|
| KIT | • | N° 5 | — | K.080.1.3.C | Min. 600 mm | 4x |
| | | — | — | K.080.1.3.S | Min. 600 mm | 4x |
| BLISTER | • | N° 4 | — | B.080.1.3.C150 | 700 ÷ 850 mm | 4x |
| | | N° 5 | — | B.080.1.3.C165 | 860 ÷ 950 mm | 4x |
| | | N° 5 | — | B.080.1.3.C200 | 960 ÷ 1100 mm | 4x |
| | | N° 6 | — | B.080.1.3.C250 | 1110 ÷ 1350 mm | 4x |
| | | N° 7 | — | B.080.1.3.C300 | 1360 ÷ 1600 mm | 4x |
| | | — | — | B.080.1.3.S150 | 700 ÷ 850 mm | 4x |
| | | — | — | B.080.1.3.S165 | 860 ÷ 950 mm | 4x |
| | | — | — | B.080.1.3.S200 | 960 ÷ 1100 mm | 4x |
| | | — | — | B.080.1.3.S250 | 1110 ÷ 1350 mm | 4x |
| | | — | — | B.080.1.3.S300 | 1360 ÷ 1600 mm | 4x |

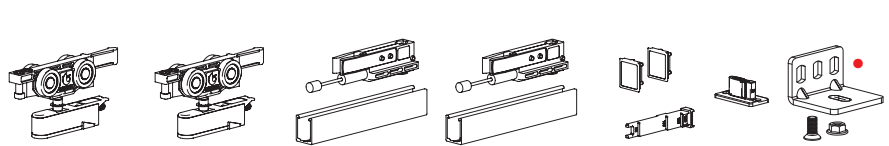

ART. 1280
(8000.01280)
(8010.01280)

FLUID

80 kg

N.2 Shock absorber
N.2 Fermi a pinza ammortizzati

Ball bearings
Cuscinetti a sfera

| | | OLD CODE | NEW CODE | | TRACK-BINARIO | |
|----------------|---|----------|----------|-----------------------|----------------|----|
| KIT | • | N° 5 | — | K.080.3.3.C | Min. 600 mm | 5x |
| | | — | — | K.080.3.3.S | Min. 600 mm | 5x |
| BLISTER | • | N° 4 | — | B.080.3.3.C150 | 700 ÷ 850 mm | 4x |
| | | N° 5 | — | B.080.3.3.C165 | 860 ÷ 950 mm | 4x |
| | | N° 5 | — | B.080.3.3.C200 | 960 ÷ 1100 mm | 4x |
| | | N° 6 | — | B.080.3.3.C250 | 1110 ÷ 1350 mm | 4x |
| | | N° 7 | — | B.080.3.3.C300 | 1360 ÷ 1600 mm | 4x |
| | | — | — | B.080.3.3.S150 | 700 ÷ 850 mm | 4x |
| | | — | — | B.080.3.3.S165 | 860 ÷ 950 mm | 4x |
| | | — | — | B.080.3.3.S200 | 960 ÷ 1100 mm | 4x |
| | | — | — | B.080.3.3.S250 | 1110 ÷ 1350 mm | 4x |
| | | — | — | B.080.3.3.S300 | 1360 ÷ 1600 mm | 4x |

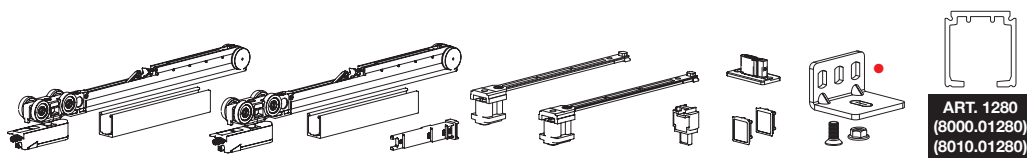

| | | OLD CODE | NEW CODE | | | |
|----------------|---|----------|----------|-----------------------|----------------|---------|
| KIT | • | N° 6 | — | K.120.2.3.C | Min. 740 mm | 4x |
| | | — | — | K.120.2.3.S | Min. 740 mm | 4x |
| BLISTER | • | N° 4 | — | B.120.2.3.C150 | 740 ÷ 850 mm | 1500 mm |
| | | N° 5 | — | B.120.2.3.C165 | 860 ÷ 950 mm | 1650 mm |
| | | N° 5 | — | B.120.2.3.C200 | 960 ÷ 1100 mm | 2000 mm |
| | | N° 6 | — | B.120.2.3.C250 | 1110 ÷ 1350 mm | 2500 mm |
| | | N° 7 | — | B.120.2.3.C300 | 1360 ÷ 1600 mm | 3000 mm |
| | | — | — | B.120.2.3.S150 | 700 ÷ 850 mm | 1500 mm |
| | | — | — | B.120.2.3.S165 | 860 ÷ 950 mm | 1650 mm |
| | | — | — | B.120.2.3.S200 | 960 ÷ 1100 mm | 2000 mm |
| | | — | — | B.120.2.3.S250 | 1110 ÷ 1350 mm | 2500 mm |
| | | — | — | B.120.2.3.S300 | 1360 ÷ 1600 mm | 3000 mm |

120 kg

N.2 Fluid dampers
 N.2 Fermi ammortizzati
FLUID Fluid

Ball bearings
Cuscinetti a sfera

FLUID

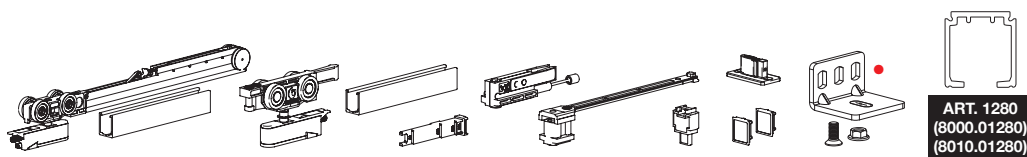

| | | OLD CODE | NEW CODE | | | |
|----------------|---|----------|----------|-----------------------|----------------|---------|
| KIT | • | N° 6 | — | K.120.1.3.C | Min. 600 mm | 4x |
| | | — | — | K.120.1.3.S | Min. 600 mm | 4x |
| BLISTER | • | N° 4 | — | B.120.1.3.C150 | 700 ÷ 850 mm | 1500 mm |
| | | N° 5 | — | B.120.1.3.C165 | 860 ÷ 950 mm | 1650 mm |
| | | N° 5 | — | B.120.1.3.C200 | 960 ÷ 1100 mm | 2000 mm |
| | | N° 6 | — | B.120.1.3.C250 | 1110 ÷ 1350 mm | 2500 mm |
| | | N° 7 | — | B.120.1.3.C300 | 1360 ÷ 1600 mm | 3000 mm |
| | | — | — | B.120.1.3.S150 | 700 ÷ 850 mm | 1500 mm |
| | | — | — | B.120.1.3.S165 | 860 ÷ 950 mm | 1650 mm |
| | | — | — | B.120.1.3.S200 | 960 ÷ 1100 mm | 2000 mm |
| | | — | — | B.120.1.3.S250 | 1110 ÷ 1350 mm | 2500 mm |
| | | — | — | B.120.1.3.S300 | 1360 ÷ 1600 mm | 3000 mm |

120 kg

N.1 Fluid damper
 N.1 Fermo ammortizzato
FLUID Fluid

N.1 Shock absorber
 N.1 Fermo a pinza ammortizzato

Ball bearings
Cuscinetti a sfera

FLUID

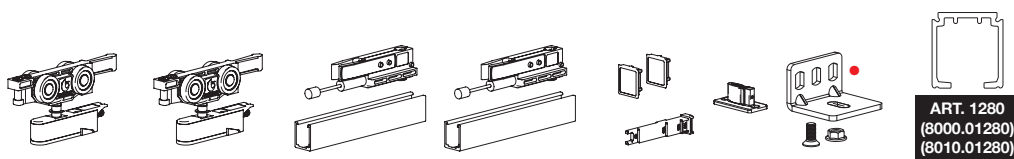

| | | OLD CODE | NEW CODE | | | |
|----------------|---|----------|----------|-----------------------|----------------|---------|
| KIT | • | N° 6 | — | K.120.3.3.C | Min. 600 mm | 5x |
| | | — | — | K.120.3.3.S | Min. 600 mm | 5x |
| BLISTER | • | N° 4 | — | B.120.3.3.C150 | 700 ÷ 850 mm | 1500 mm |
| | | N° 5 | — | B.120.3.3.C165 | 860 ÷ 950 mm | 1650 mm |
| | | N° 5 | — | B.120.3.3.C200 | 960 ÷ 1100 mm | 2000 mm |
| | | N° 6 | — | B.120.3.3.C250 | 1110 ÷ 1350 mm | 2500 mm |
| | | N° 7 | — | B.120.3.3.C300 | 1360 ÷ 1600 mm | 3000 mm |
| | | — | — | B.120.3.3.S150 | 700 ÷ 850 mm | 1500 mm |
| | | — | — | B.120.3.3.S165 | 860 ÷ 950 mm | 1650 mm |
| | | — | — | B.120.3.3.S200 | 960 ÷ 1100 mm | 2000 mm |
| | | — | — | B.120.3.3.S250 | 1110 ÷ 1350 mm | 2500 mm |
| | | — | — | B.120.3.3.S300 | 1360 ÷ 1600 mm | 3000 mm |

120 kg

N.2 Shock absorber
 N.2 Fermi a pinza ammortizzati

Ball bearings
Cuscinetti a sfera

FLUID

N.2 Fluid dampers
N.2 Fermi ammortizzati Fluid

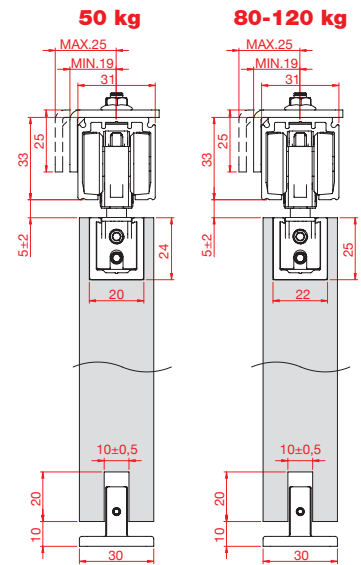
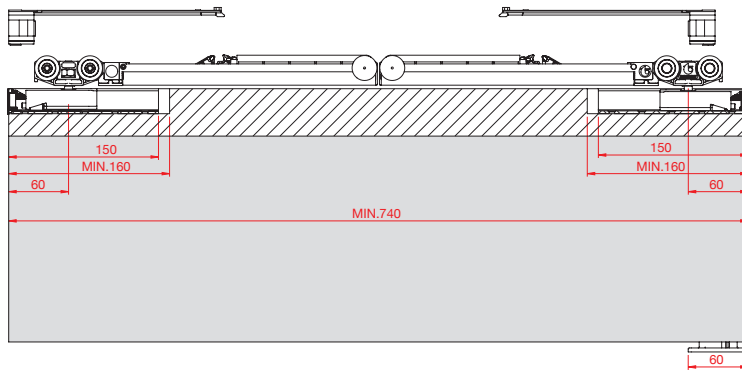

N.1 Fluid damper + N.1 Shock absorber
N.1 Fermo ammortizzato Fluid + N.1 Fermo a pinza ammortizzato

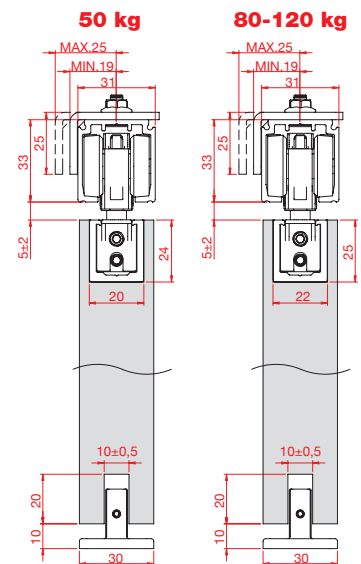
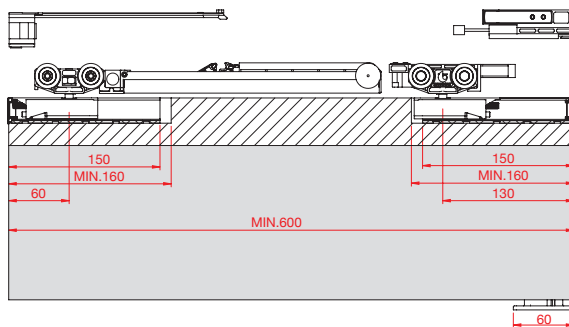

N.2 Shock absorber
N.2 Fermi a pinza ammortizzati

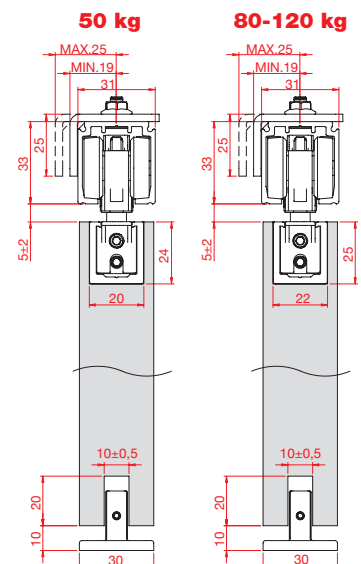
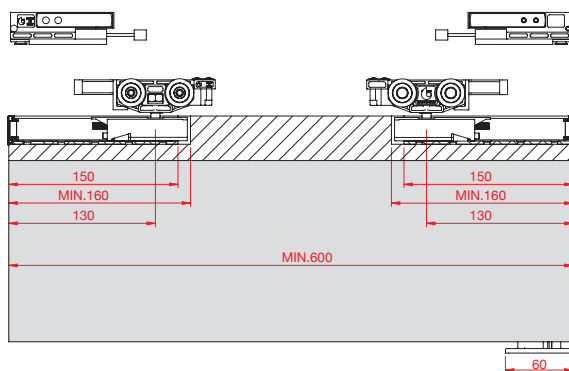

FLUID



50 kg
80 kg
120 kg



Fluid Technology

The future of sliding systems has started!

The best sliding quality possible, functional noise voided, extremely light movements in door opening and closing.

A new system which suits to all bracket series of Terno Scorrevoli catalogue.

Il futuro dello scorrevole è iniziato!

La miglior scorrevolezza possibile, rumorosità azzerata, movimenti in apertura e chiusura estremamente morbidi.

Un nuovo sistema che si adatta a tutte le staffe presenti nel catalogo Terno Scorrevoli.

PATENTED

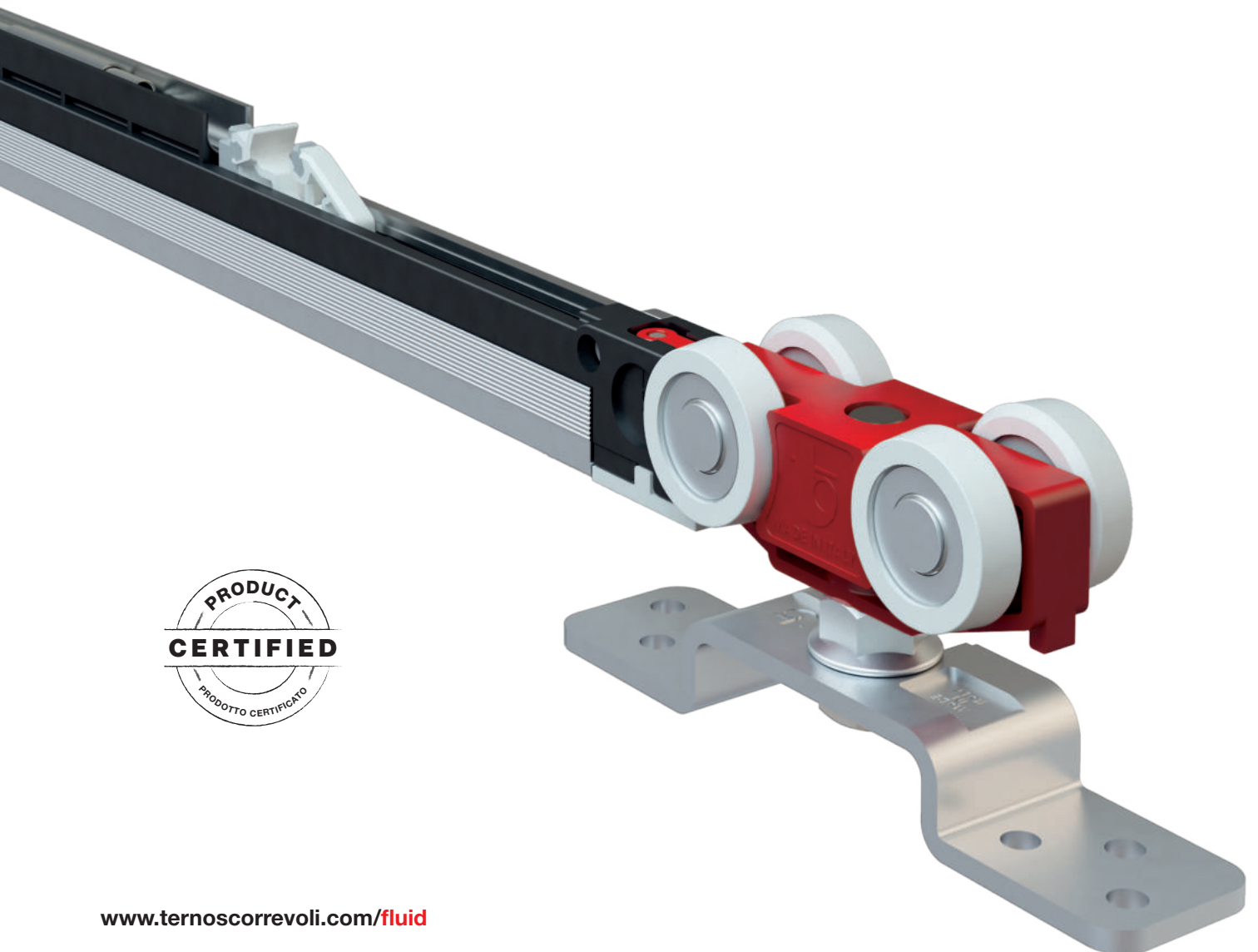

The soft-closing damper of **Fluid** system introduces an important novelty, given that the damper case is directly connected to sliding trolley and it includes an hydraulic piston which brakes the door on its movement. Therefore closing motion is led by a structure, equipped with two springs located in the upper and in the bottom side of the slide. In this way, in both direction, the movement will result extremely soft, fluid and light, even with heavier weight (up to 120kg). New **Fluid** system has been designed, indeed, for 50, 80 and 120 kg doors.

Il fermo ammortizzato del sistema **Fluid** presenta un'importante novità: allo scorrevole, infatti, è avvitato il sostegno per il supporto di frenatura. Questo supporto è dotato di un pistone idraulico che frena il movimento della porta. La chiusura viene quindi effettuata da una struttura con due molle posizionate nella parte superiore e nella parte inferiore dello scorrevole.

In questo modo, sia l'apertura che la chiusura della porta risultano estremamente morbide, fluide e leggere, anche con pesi elevati (fino a 120 kg).

Il nuovo sistema **Fluid** è stato realizzato, infatti, per porte da 50, 80 e 120 kg.

Double return spring

Doppia molla di ritorno



One of the most innovative features of **Fluid** system is the shock absorber. To the traditional standard stopper, it has been added a braking piston and two leaf springs to ease the holding of pliers.

The revolution lies in the fact that, with two very simple screws, it is possible to add on the sliding trolley the support needed for the activation of stopper and to avoid any shock during door's closing motion.

Combining, indeed, the new shock absorber with a damper stopper, it will be possible to realize narrow doors, starting from 600 mm.

With the same sliding trolley body it will be possible to use three different type of stoppers: **Fluid** damper with double return spring, shock absorber and traditional standard stopper.

Una delle caratteristiche più innovative del sistema **Fluid** è il fermo a pinza ammortizzato.

Al classico fermo a pinza, sono stati aggiunti un pistone frenante e due molle a balestra che aiutano la tenuta delle due pinze.

La rivoluzione consiste nel fatto che con due semplicissime viti, si può aggiungere, sopra lo scorrevole, il supporto necessario per l'attivazione del fermo ed evitare qualsiasi tipo di impatto durante il movimento della porta.

Abbinando quindi questo nuovo fermo a pinza ammortizzato ed un fermo ammortizzato, si possono realizzare porte di larghezza ridotta, a partire da 600 mm.

Con un'unica struttura del sistema scorrevole, si possono quindi utilizzare tre tipologie di fermi: il fermo ammortizzato con doppia molla di rientro, il fermo a pinza ammortizzato, e il fermo standard a pinza.



Shock absorber Fermo a pinza ammortizzato

Reduced minimum door width

New **Fluid** system has been designed for doors weighing 50, 80 and 120 kg and it grants, for all these weight classes, an extremely light opening/closing sliding motion, always having the same encumbrance. Door's width realizable will be then reduced, thanks to Fluid system, of circa 100mm each side compared to previous models.

Even in door's configuration with two dampers, the minimal width will be 740 mm, so reduced of 200 mm than former models, with no need of special twin dampers.

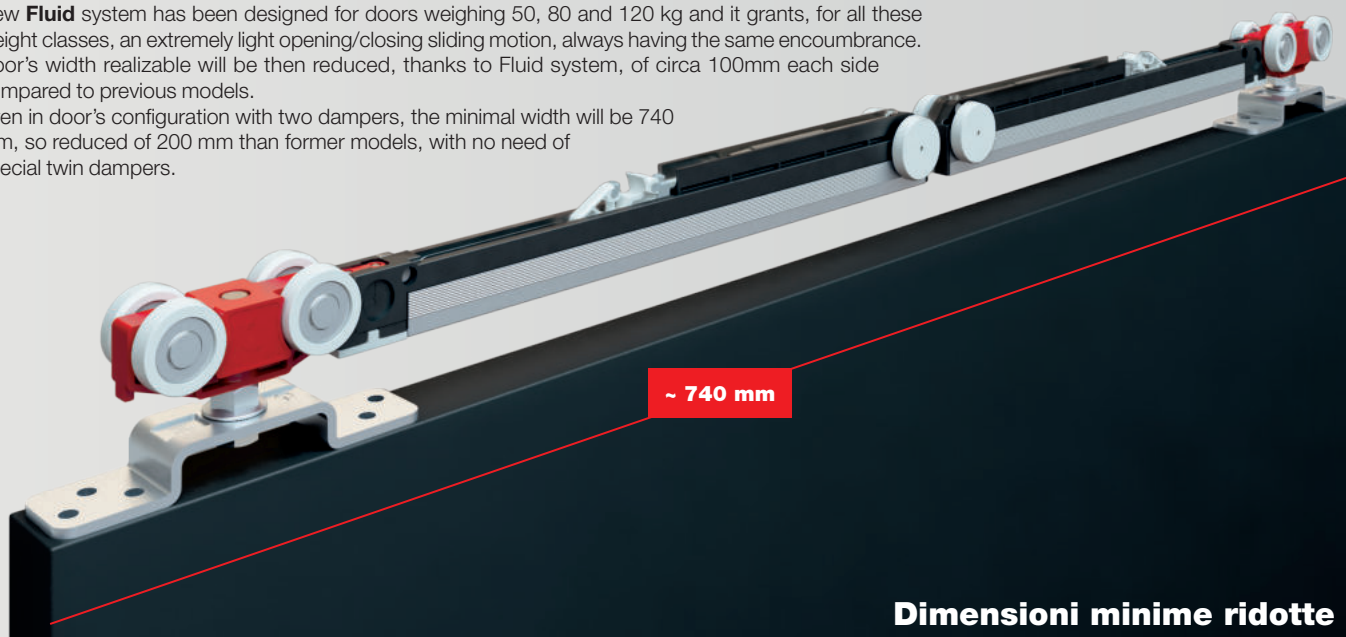

Il nuovo sistema **Fluid** ha le medesime dimensioni per tutte e tre le portate. La lunghezza della porta è così ridotta di circa 100 mm rispetto ai modelli precedenti: anche nelle versioni di porte con ammortizzatori posti ai due lati, la larghezza minima risulta essere di 740 mm; si riducono quindi di circa 200 mm le misure minime precedenti, senza dover utilizzare fermi ammortizzati doppi speciali.

Smooth and quiet sliding

Sliding trolley wheels are equipped with coated bearings of large dimension and independent inertial dampers, laterally positioned. These inertial dampers, inserted between bearings and related rigid support, allow the wheels to slide uniformly leaning on the track, even in case of wall defects or not aligned installation of the track itself. These innovations allow to cut vibration off during the motion, reducing functional noise and granting the best sliding quality possible.

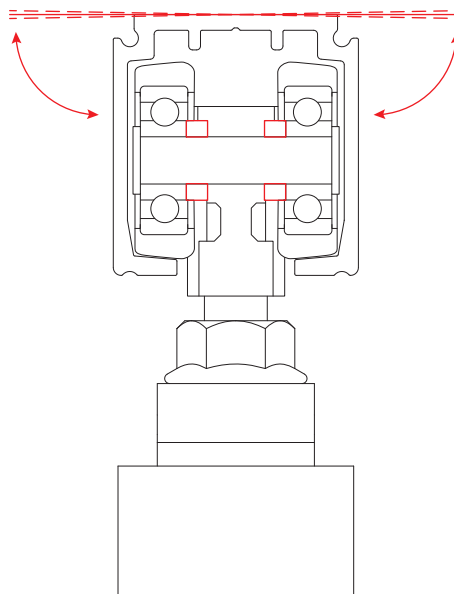

Scorrevolezza e silenziosità

Le ruote dello scorrevole hanno cuscinetti rivestiti di grandi dimensioni e smorzatori indipendenti, posti lateralmente.

Questi smorzatori elastici, inseriti tra i cuscinetti e il supporto rigido, permettono alle ruote di scorrere sempre in modo uniforme in appoggio al binario, anche in caso di imperfezioni delle pareti o montaggio non lineare del binario.

Queste innovazioni permettono di tagliare le vibrazioni del movimento, riducendo la rumorosità di scorrimento e garantendo la miglior scorrevolezza possibile.

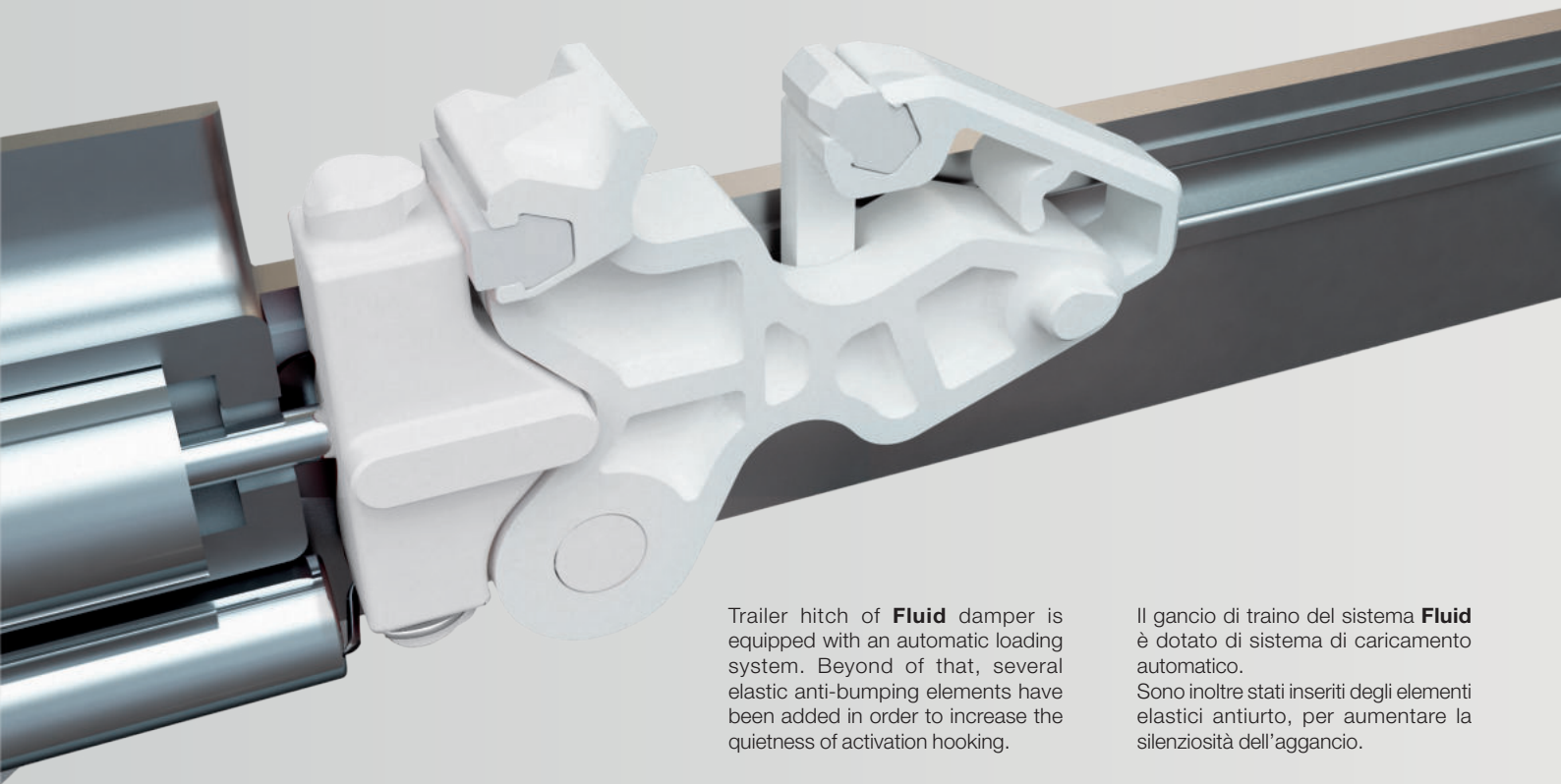

Trailer hitch of **Fluid** damper is equipped with an automatic loading system. Beyond of that, several elastic anti-bumping elements have been added in order to increase the quietness of activation hooking.

Il gancio di traino del sistema **Fluid** è dotato di sistema di caricamento automatico. Sono inoltre stati inseriti degli elementi elastici antiurto, per aumentare la silenziosità dell'aggancio.

Improved sliding motion

The new activator of **Fluid** damper is made in Zamak (resistant and versatile material). It is equipped with a rounded edge and elastic elements which are meant to avoid any vibration during the contact with aluminium. The trailer hitch rotation has been improved with no functional noise.

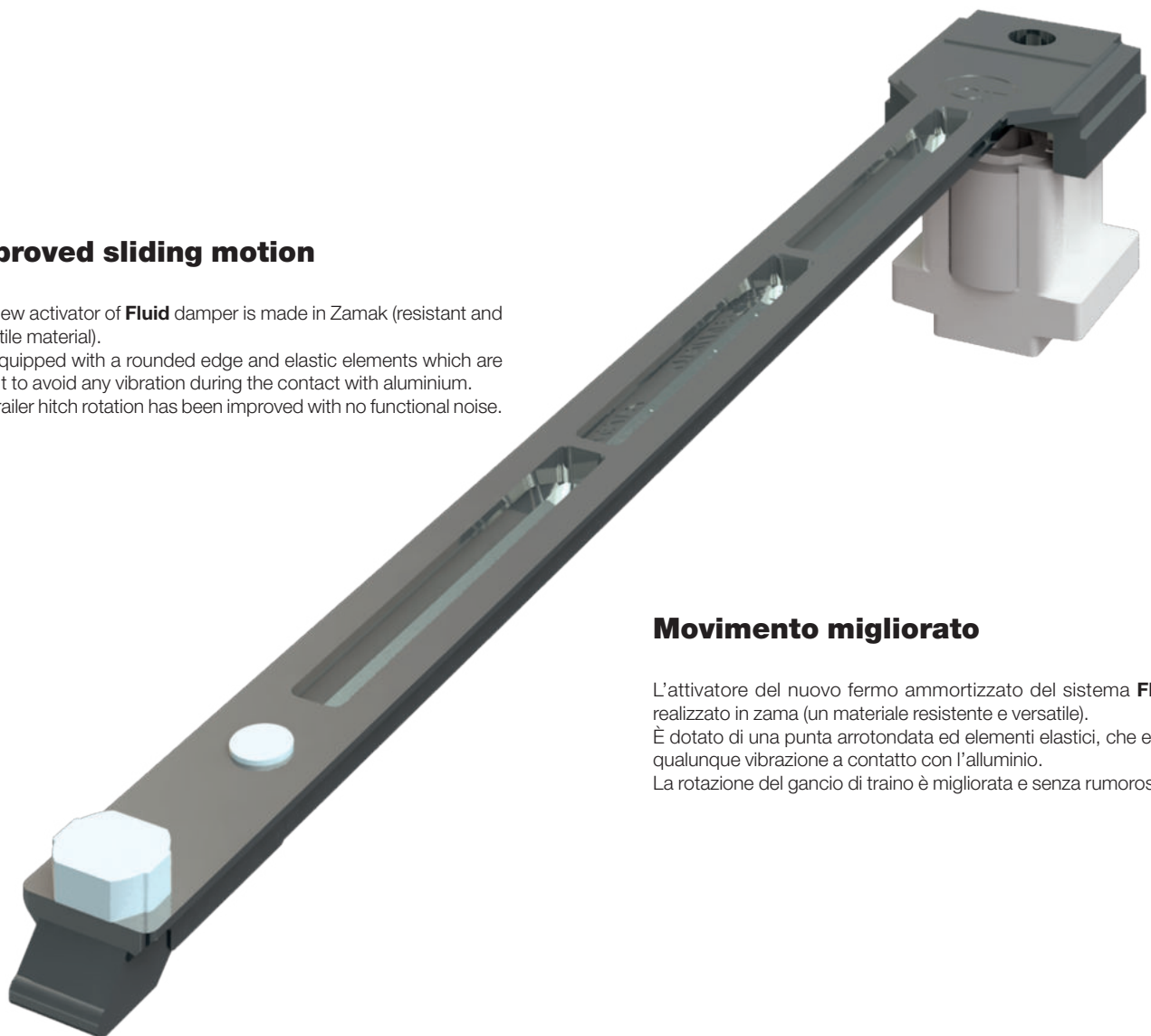

Movimento migliorato

L'attivatore del nuovo fermo ammortizzato del sistema **Fluid** è realizzato in zama (un materiale resistente e versatile). È dotato di una punta arrotondata ed elementi elastici, che evitano qualunque vibrazione a contatto con l'alluminio. La rotazione del gancio di traino è migliorata e senza rumorosità.

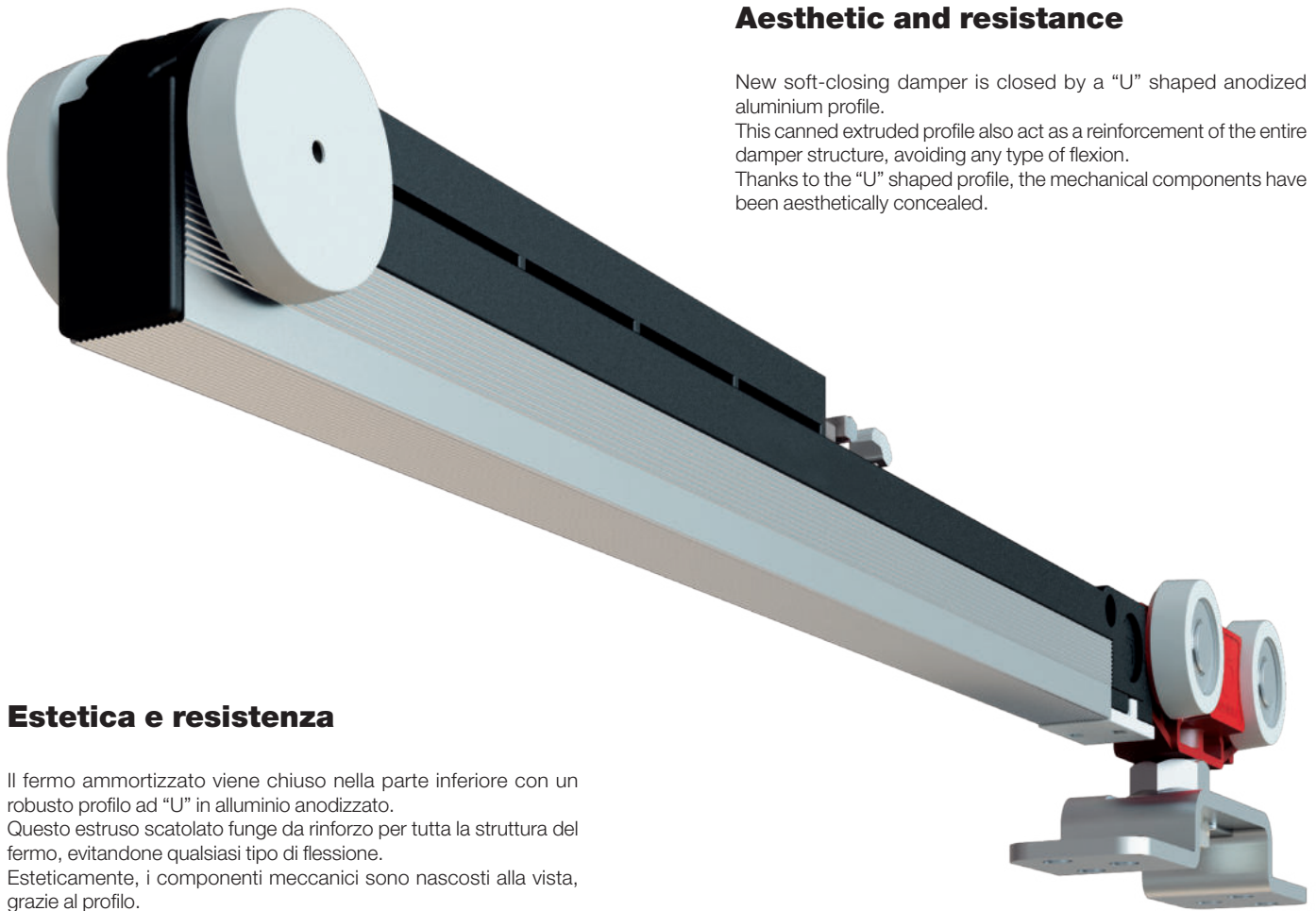

Aesthetic and resistance

New soft-closing damper is closed by a "U" shaped anodized aluminium profile.

This canned extruded profile also act as a reinforcement of the entire damper structure, avoiding any type of flexion.

Thanks to the "U" shaped profile, the mechanical components have been aesthetically concealed.

Estetica e resistenza

Il fermo ammortizzato viene chiuso nella parte inferiore con un robusto profilo ad "U" in alluminio anodizzato.

Questo estruso scatolato funge da rinforzo per tutta la struttura del fermo, evitandone qualsiasi tipo di flessione.

Esteticamente, i componenti meccanici sono nascosti alla vista, grazie al profilo.

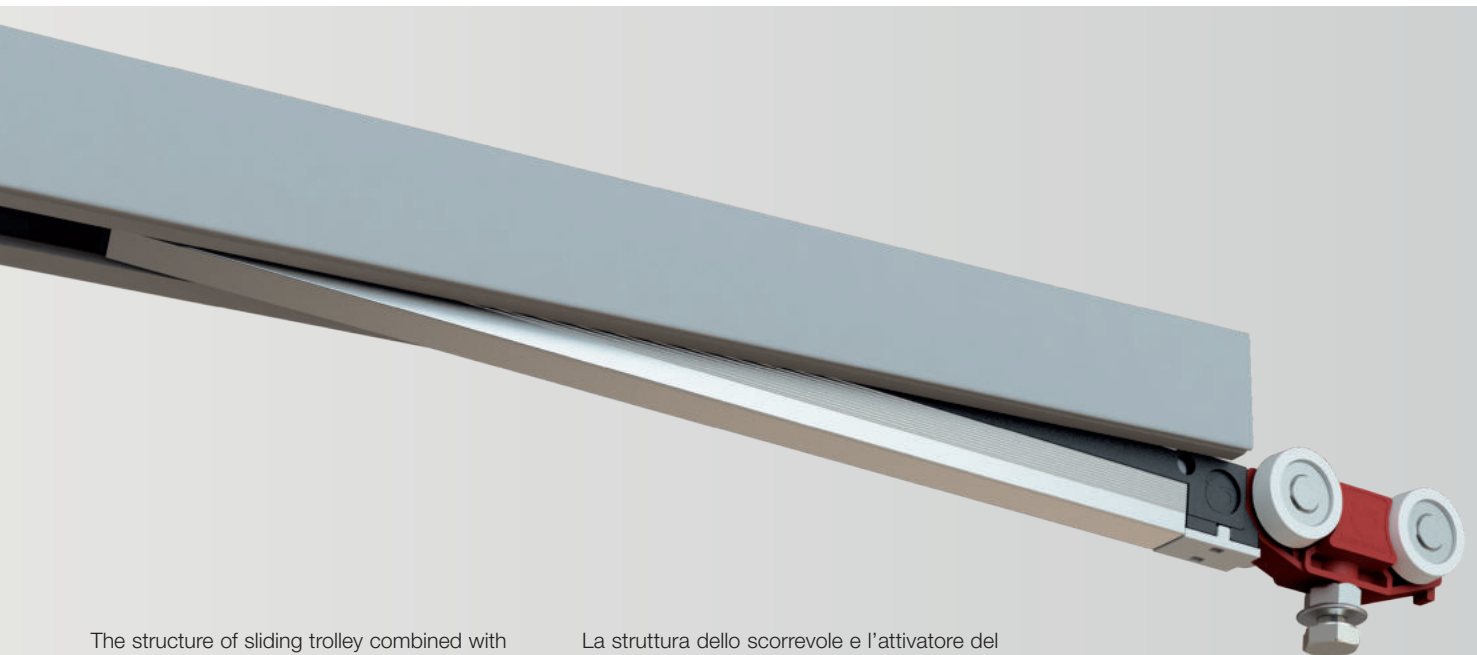

The structure of sliding trolley combined with damper has been reduced and therefore they can be inserted into Terno Scorrevoli profiles from the bottom side, especially in case of wall pocket doors or counterceiling.

La struttura dello scorrevole e l'attivatore del fermo hanno dimensioni ridotte.

Gli scorrevoli possono essere inseriti nei nostri profili dalla parte inferiore, in caso di porte incassate nel soffitto o in controsoffitto.

Fluid

WHY CHOOSE / PERCHÈ SCEGLIERLO

The new damper with double return spring will grant **the best sliding quality possible either on opening or on closing direction.**

1

Il fermo ammortizzato, con la doppia molla di rientro, garantisce **la miglior scorrevolezza in apertura e chiusura.**

New sliding trolley's integrated technologies allow a **soft and light movement, even up to 120 kg.**

2

Le nuove tecnologie integrate nello scorrevole permettono **movimenti morbidi e leggeri fino a portate da 120 kg.**

Reduced doors dimensions: with two soft-closing dampers, it's possible to realize a door with a minimum width of 740 mm. With one soft-closing damper and a new shock absorber, the minimum width realizable is 600 mm.

3

Dimensioni delle porte ridotte: con i due fermi ammortizzati, si ha una larghezza minima di 740 mm. Con un fermo ammortizzato e il nuovo fermo a pinza ammortizzato, la larghezza minima è di 600 mm.

The new system is **extremely quiet**, due to several elastic elements which have been used and which are acting to reduce functional noise.

4

Il nuovo sistema è **estremamente silenzioso:** sono stati inseriti diversi elementi elastici che riducono la rumorosità del sistema.

Even if **the soft-closing damper structure has been reinforced**, thanks to the canned extruded profile the aesthetic remains **clean and elegant.**

5

La **struttura è rinforzata**, ma esteticamente, grazie ai nuovi profili scatolati, risulta **pulita ed elegante.**

Fluid

COMPLETE BOX KIT / KIT COMPLETO IN SCATOLA



| K | | Complete kit / Kit completo | |
|---|-----|---|---|
| | 030 | | |
| | 040 | | |
| | 050 | | |
| | 080 | | |
| | 120 | | |
| | 160 | | |
| | 180 | | |
| | 240 | | |
| | 250 | | |
| | 0 | N.2 Standard stoppers N.2 Fermi standard | |
| | 1 | N.1 Fluid damper + N.1 Shock absorber N.1 Fermo Fluid + N.1 Fermo a pinza ammortizzato | |
| | 2 | N.2 Fluid dampers N.2 Fermi ammortizzati Fluid | |
| | 3 | N.2 Shock absorber N.2 Fermi a pinza ammortizzati | |
| | 4 | N.2 Soft-closing dampers - Naval sector N.2 Fermi ammortizzati - Settore navale | |
| | 5 | N.1 Soft-closing damper + N.1 Standard stopper N.1 Fermo ammortizzato + N.1 Fermo standard | |
| | 6 | N.2 Soft-closing dampers N.2 Fermi ammortizzati | |
| | 1 | Classic | |
| | 2 | Step | |
| | 3 | Evolution | |
| | 4 | Eclettica | |
| | 5 | Hide | |
| | | | S |
| | | | C |

EXAMPLE / ESEMPIO

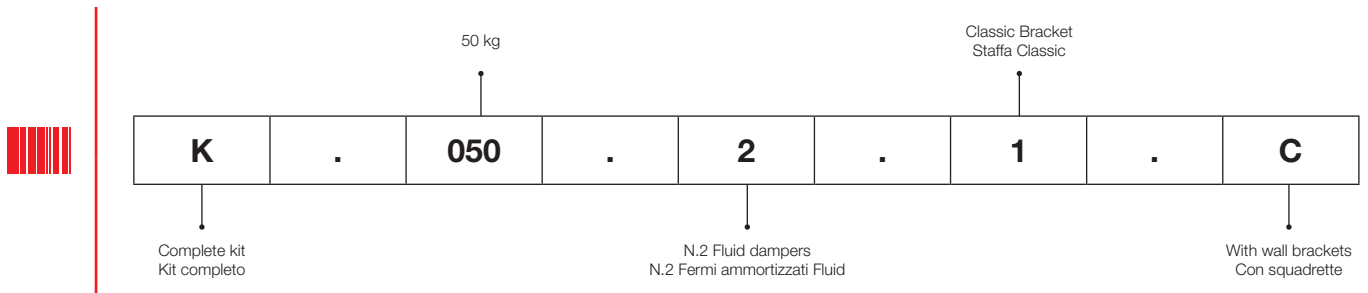

| Tracks / Binari | | ALUMINUM FINISHES CODES / CODICI FINITURE ALLUMINIO | | |
|-----------------|----------------|---|--|-----------------|
| CODE / CODICE | | FINISH COLOR / COLORE FINITURA | | |
| 8 00 0.0 | 00 G | Raw / Mill Finish / Neutro / Grezzo | | STANDARD |
| 8 01 0.0 | 01 A | Anodized Silver / Argento | | |
| 8 02 0.0 | 02 AS | Brushed Anodized Silver / Argento Spazzolato | | |
| 8 13 0.0 | 13 E3S | Brushed Anodized Dark Brown / E3 Spazzolato | | SPECIAL |
| 8 15 0.0 | 15 NS | Brushed Anodized Black / Nero Spazzolato | | |
| 8 17 0.0 | 17 NKS | Brushed Anodized Nickel / Nichel Spazzolato | | |
| 8 25 0.0 | 25 GRFS | Brushed Anodized Graphite / Grafite Spazzolato | | |

| Tracks / Binari | | PLASTIC FINISHES CODES / CODICI FINITURE PLASTICA | | |
|-----------------|--------------|---|--|-----------------|
| CODE / CODICE | | FINISH COLOR / COLORE FINITURA | | |
| 8 23 0.0 | 23 GR | Gray / Grigio | | STANDARD |
| 8 14 0.0 | 14 N | Anodized Black / Nero | | |



Foldy

Folding doors with external hinge opening

Porte pieghevoli con apertura tramite cerniere esterne o cardini





Foldy is a **system for wooden folding doors with external hinges opening.**

The system has **multiple configurations**, able to satisfy any need: Foldy is made up of two equal doors or two unequal doors; the doors can be close together or spaced; the system is compatible with external hinges.

Finally, **Foldy** integrates the possibility of opening the doors both to the right and to the left.

Foldy è il **sistema per porte pieghevoli e per porte a libro in legno**, con apertura tramite cerniere esterne o cardini.

Il sistema ha **molteplici configurazioni**, in grado di soddisfare qualsiasi esigenza: Foldy si compone, infatti, di due ante pari o due ante disuguali; le ante possono essere ravvicinate o distanziate; il sistema è compatibile con cerniere esterne oppure cardini.

Foldy, infine, integra la possibilità di apertura delle porte sia a destra che a sinistra.





Foldy

COMPLETE BOX KIT / KIT COMPLETO IN SCATOLA

| | | | | | |
|----------|-----------------------------|------|--|----------------------------------|---|
| K | Complete kit / Kit completo | | | | |
| | | 0211 | | | |
| | | 0212 | | | |
| | | 0213 | | Spaced doors Ante distanziate | |
| | | | | | |
| | | | | 1 | With hinges Con cardini |
| | | | | 2 | With hinges - ART. 1751 Con cerniere - ART. 1751 |
| | | | | 3 | With hinges - ART. 1753 Con cerniere - ART. 1753 |
| | | | | 4 | With hinges - ART. 1755 Con cerniere - ART. 1755 |
| | | | | 5 | With hinges - ART. 1757 Con cerniere - ART. 1757 |
| | | | | | |
| | | | | | |
| | | | | 1 | Opening to the right and left Apertura a destra e sinistra |
| | | | | 2 | Opening to the right Apertura a destra |
| | | | | 3 | Opening to the left Apertura a sinistra |

EXAMPLE / ESEMPIO

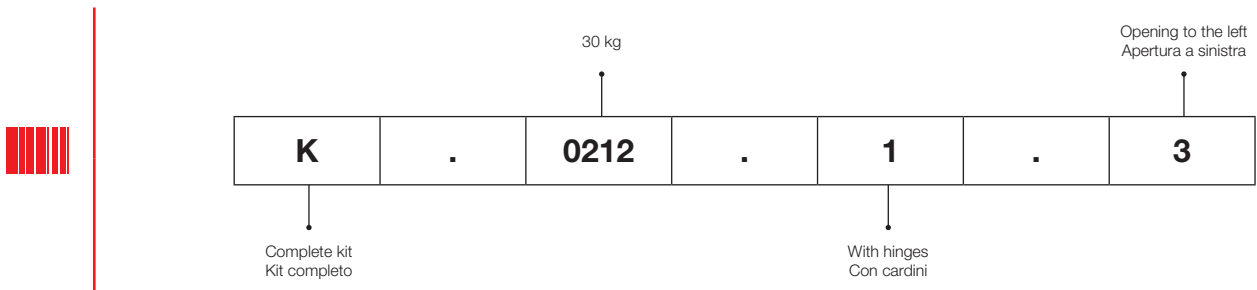

Tracks / Binari

ALUMINUM FINISHES CODES / CODICI FINITURE ALLUMINIO



| CODE / CODICE | FINISH COLOR / COLORE FINITURA | |
|-----------------|--------------------------------|-------------------------------------|
| 8 00 0.0 | 00 G | Row - Mill Finish / Neutro - Grezzo |
| 8 01 0.0 | 01 A | Anodized Silver / Argento |
| STANDARD | | |

**FOLDING DOOR WITH EXTERNAL HINGE OPENING
PORTA PIEGHEVOLE CON APERTURA TRAMITE CERNIERE ESTERNE**

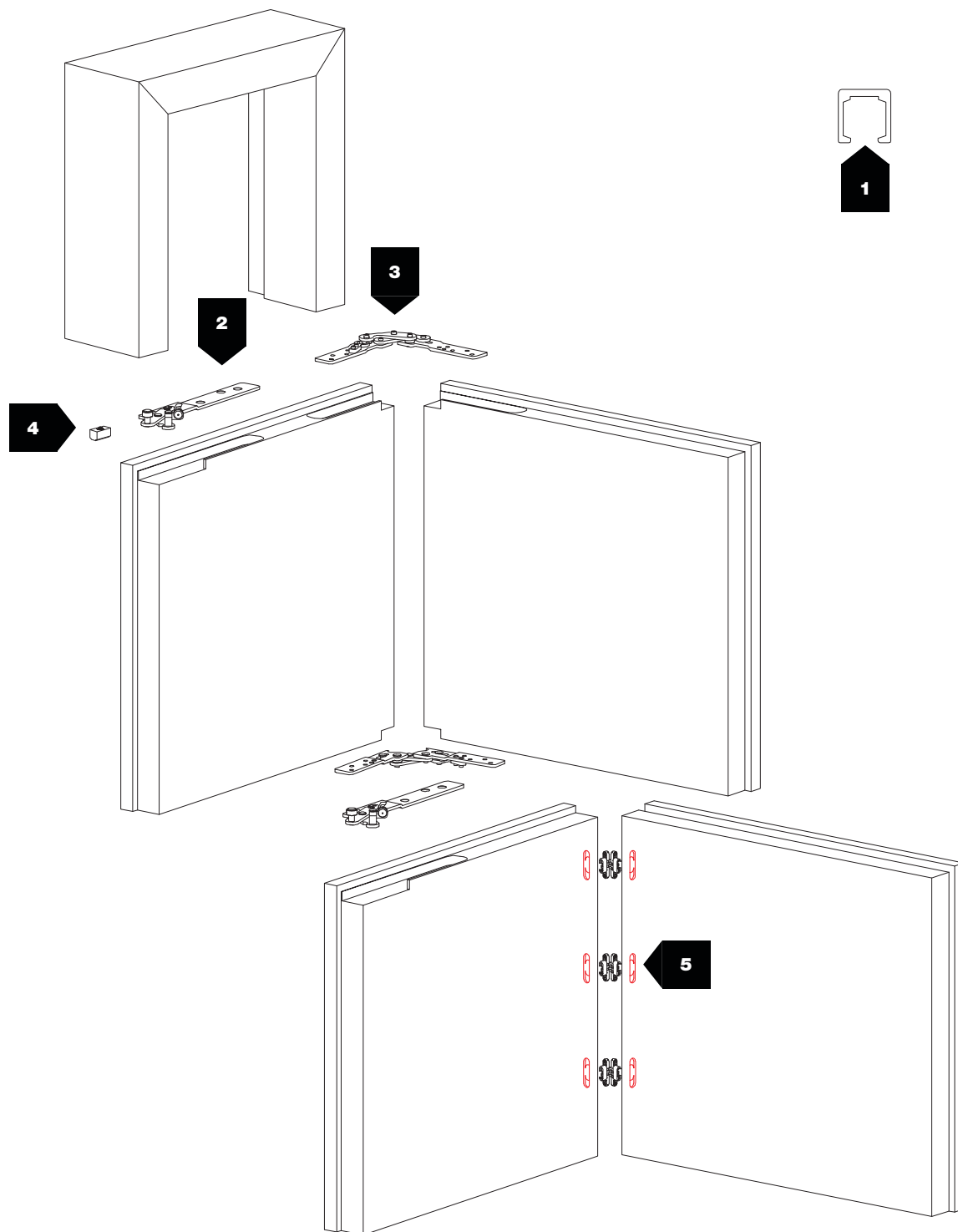

Min. 32 mm



30 ÷ 40 kg

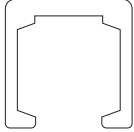
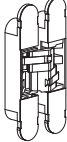
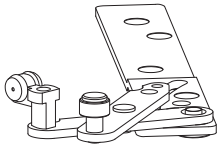
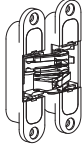
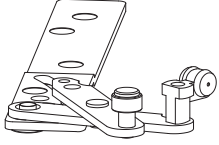
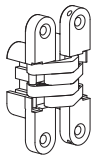
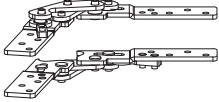
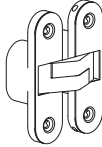
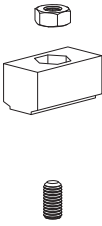

5 mm

| N° | Barcode | | kg | | N° | Barcode | | kg | |
|----|--------------------------------------|---|----|--|----|---------|---|----|--|
| 1 | 1170 8 00 0.01170 8 01 0.01170 |  | — | | 5 | 1751/N |  | 40 | |
| 2 | 1172/D/N |  | 30 | | | 1753/N |  | 40 | |
| | 1172/S/N |  | 30 | | | 1755/N |  | 40 | |
| 3 | 1174 |  | 40 | | | 1757/PI |  | 40 | |
| 4 | 1176 |  | — | | | | | | |



30 kg

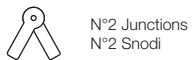

N°2 Junctions
N°2 Snodi

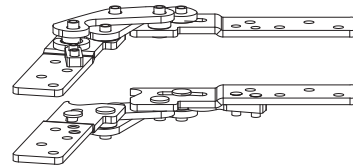
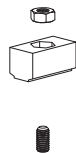
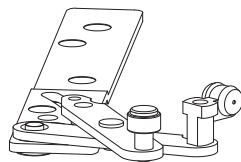

| OLD CODE | NEW CODE | | |
|---------------|------------|---|----|
| 1172/1176/S/N | K.0212.1.3 | Opening to the left / Apertura a sinistra | 5x |
| 1172/1176/D/N | K.0212.1.2 | Opening to the right / Apertura a destra | 5x |



40 kg



N°3 Hinges **ART.1751**
N°3 Cerniere **ART.1751**

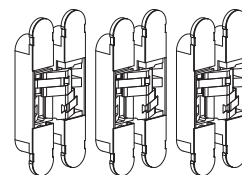
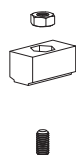
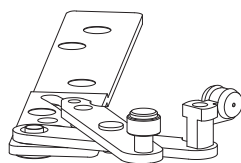

| OLD CODE | NEW CODE | | |
|---------------|------------|---|----|
| 1172/1751/N/S | K.0212.2.3 | Opening to the left / Apertura a sinistra | 5x |
| 1172/1751/N/D | K.0212.2.2 | Opening to the right / Apertura a destra | 5x |



40 kg



N°3 Hinges **ART.1753**
N°3 Cerniere **ART.1753**

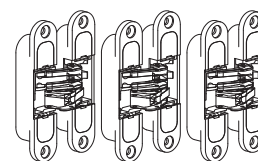
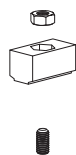
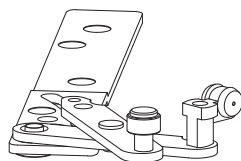

| OLD CODE | NEW CODE | | |
|---------------|------------|---|----|
| 1172/1753/N/S | K.0212.3.3 | Opening to the left / Apertura a sinistra | 5x |
| 1172/1753/N/D | K.0212.3.2 | Opening to the right / Apertura a destra | 5x |



40 kg



N°3 Hinges **ART.1755**
N°3 Cerniere **ART.1755**

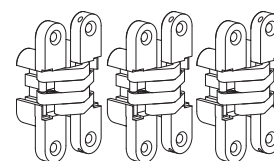
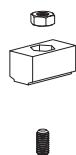
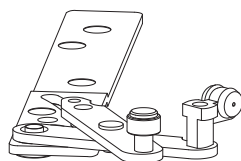

| OLD CODE | NEW CODE | | |
|---------------|------------|---|----|
| 1172/1755/N/S | K.0212.4.3 | Opening to the left / Apertura a sinistra | 5x |
| 1172/1755/N/D | K.0212.4.2 | Opening to the right / Apertura a destra | 5x |



40 kg



N°3 Hinges **ART.1757**
N°3 Cerniere **ART.1757**

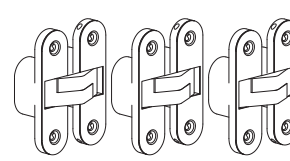
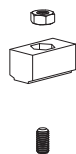
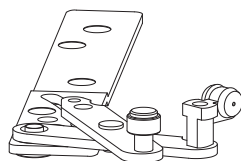

| OLD CODE | NEW CODE | | |
|---------------|------------|---|----|
| 1172/1757/P/S | K.0212.5.3 | Opening to the left / Apertura a sinistra | 5x |
| 1172/1757/P/D | K.0212.5.2 | Opening to the right / Apertura a destra | 5x |

MEASUREMENTS DESCRIPTION / DESCRIZIONI MISURE

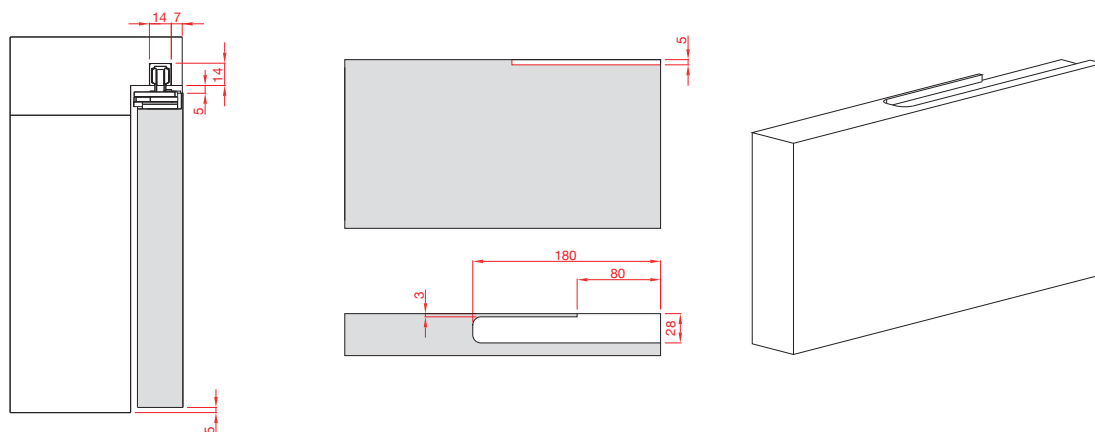

OPENING TO THE LEFT / APERTURA A SINISTRA

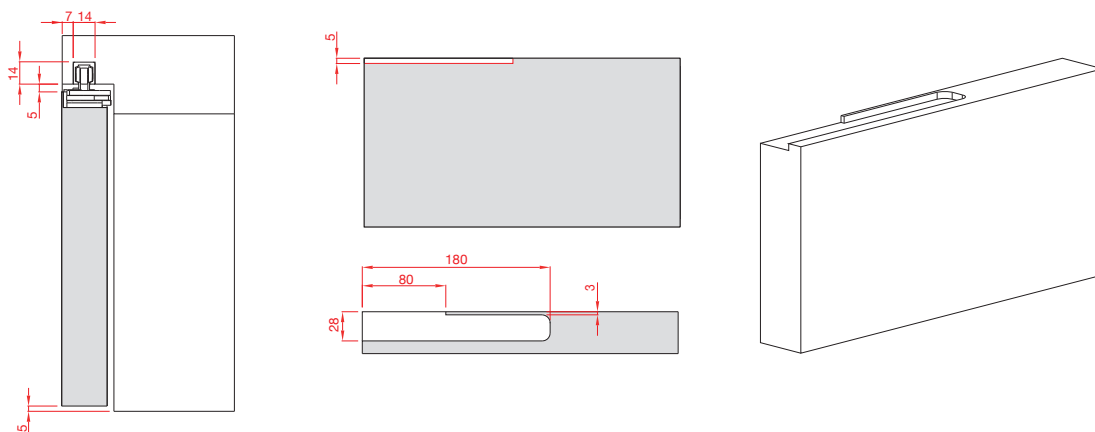

OPENING TO THE RIGHT / APERTURA A DESTRA

FOLDING DOORS WITH EQUALLY SPACED PANELS PORTE A LIBRO CON ANTE PARI RAVVICINATE

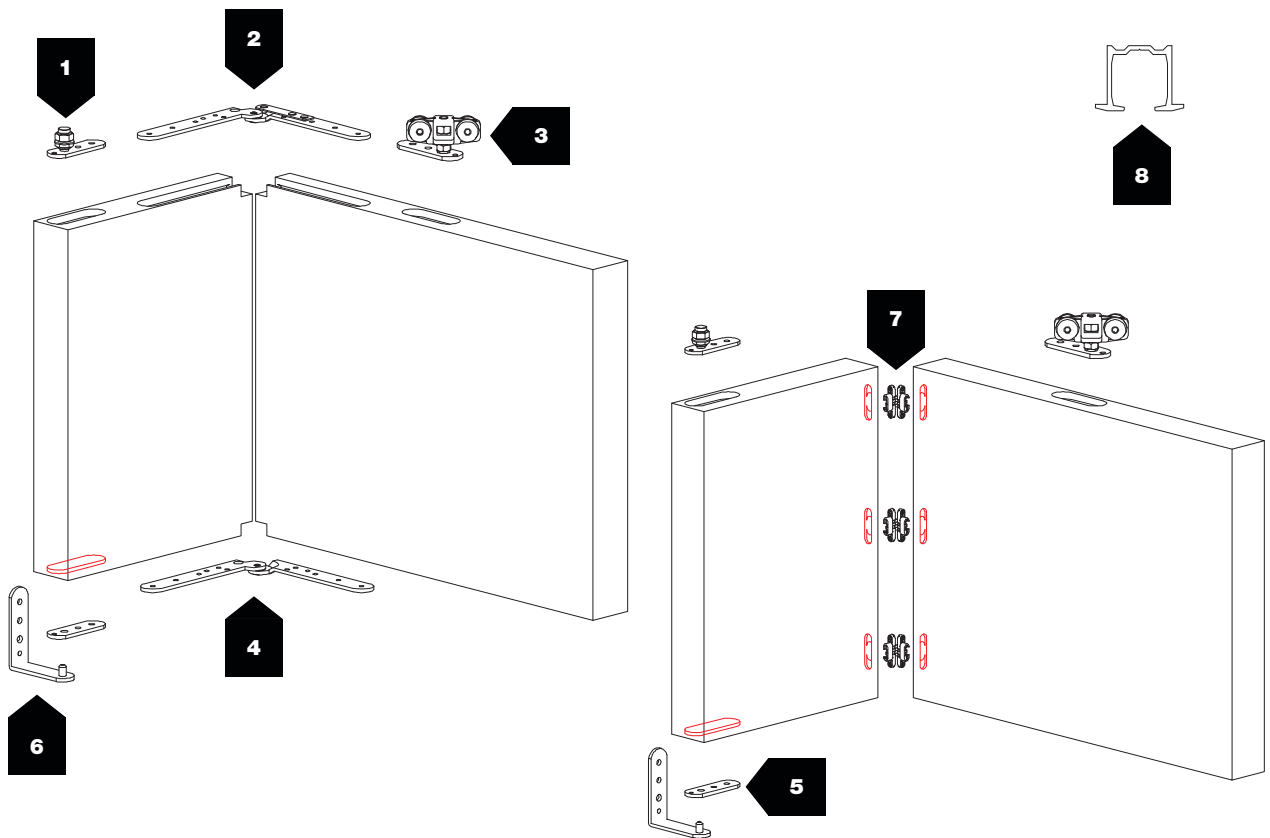
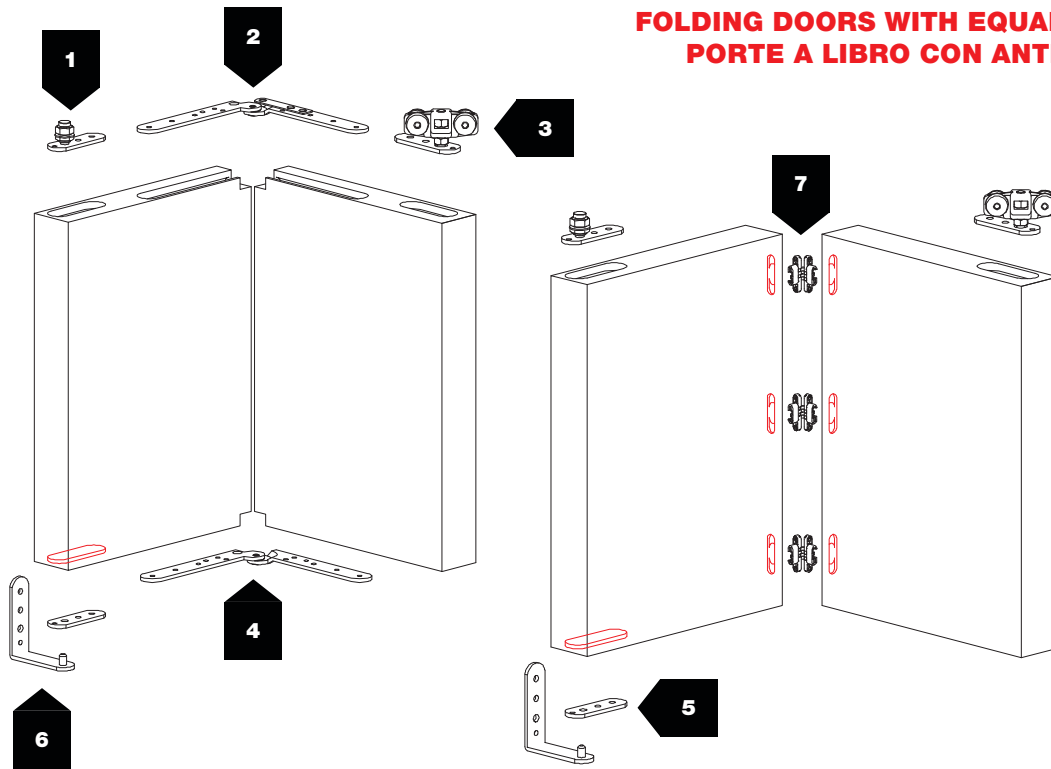

FOLDING DOORS WITH UNEQUALLY SPACED PANELS PORTE A LIBRO CON ANTE DISUGUALI RAVVICINATE







Min. 32 mm



30 ÷ 40 kg

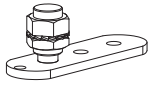
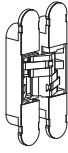

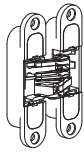
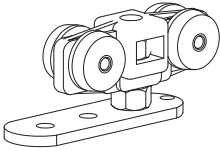
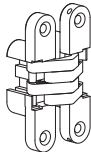
5 mm

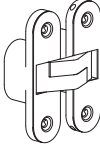
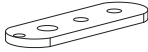
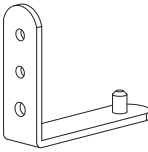
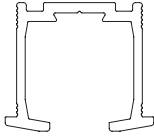
| N° | Barcode | Image | kg | | N° | Barcode | Image | kg | | |
|----|---------|---|-------|--|----|---------|---|---|---|--|
| 1 | 1133 |  | 30÷40 | | 7 | 1751/N |  | 30÷40 | | |
| 2 | 1135 |  | 30÷40 | | | 1753/N |  | 30÷40 | | |
| 3 | 1137 |  | 30÷40 | | | 1755/N |  | 30÷40 | | |
| 4 | 1138 |  | 30÷40 | | | 1757/PI |  | 30÷40 | | |
| 5 | 1136 |  | 30÷40 | | | | | | | |
| 6 | 1134 |  | 30÷40 | | | 8 | 2670 8 00 0.02670 8 01 0.02670 |  | — | |

**TWO FOLDING DOORS
DUE PORTE A LIBRO**

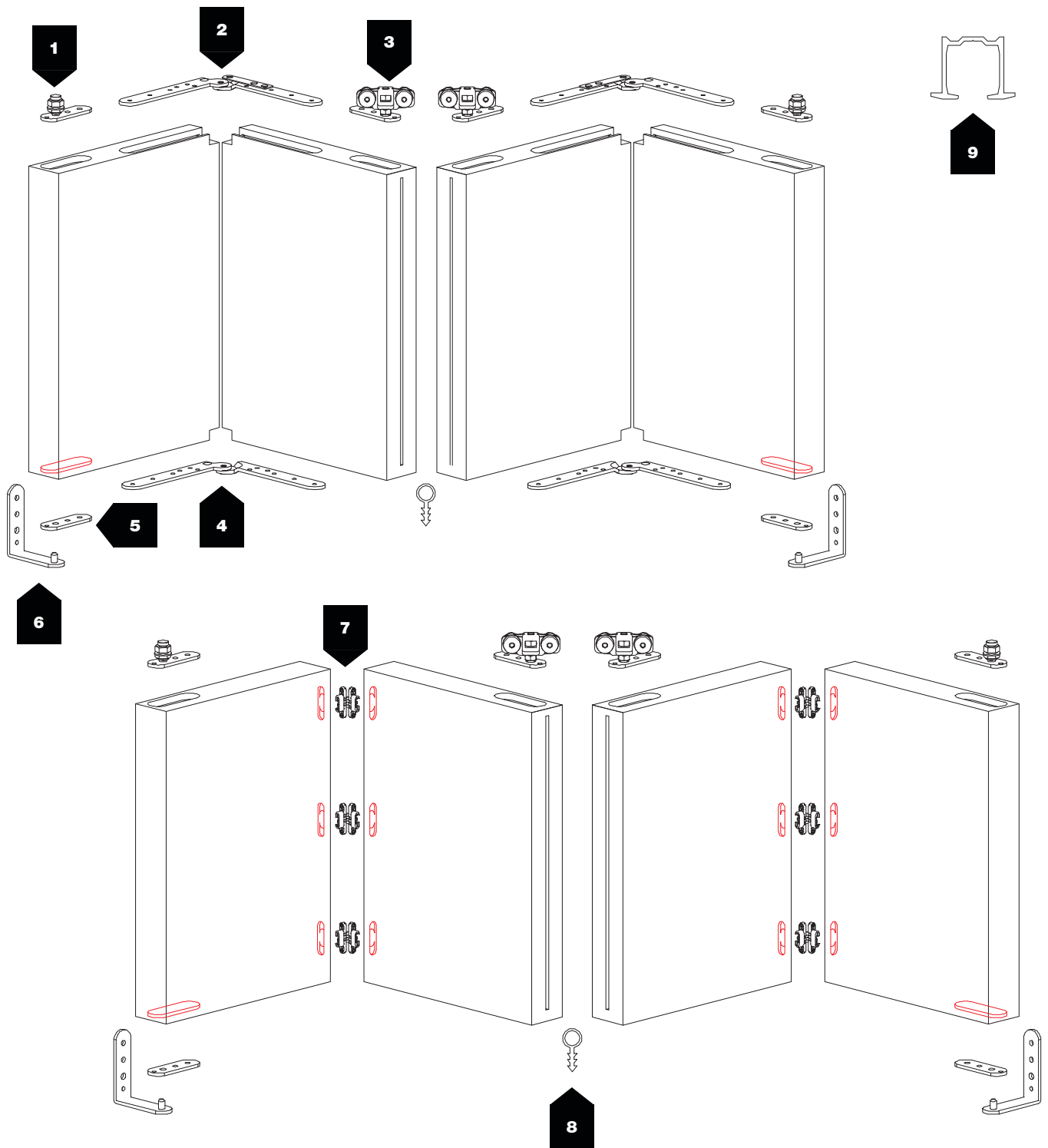







Min. 28 mm

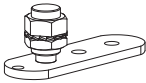
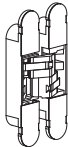

30 ÷ 40 kg

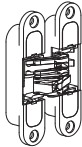
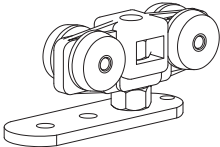
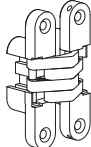

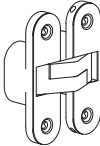
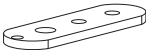
5 mm

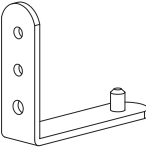
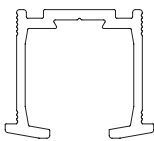
| N° | Barcode | Image | kg | | N° | Barcode | Image | kg | | |
|----|---------|---|-------|--|----|---------|---|---|-------|--|
| 1 | 1133 |  | 30÷40 | | 7 | 1751/N |  | 30÷40 | | |
| 2 | 1135 |  | 30÷40 | | | 1753/N |  | 30÷40 | | |
| 3 | 1137 |  | 30÷40 | | | 1755/N |  | 30÷40 | | |
| 4 | 1138 |  | 30÷40 | | | 1757/PI |  | 30÷40 | | |
| 5 | 1136 |  | 30÷40 | | | 8 | 894 |  | 30÷40 | |
| 6 | 1134 |  | 30÷40 | | | 9 | 2670 8 00 0.02670 8 01 0.02670 |  | — | |

 **30 kg**

 N°2 Junctions
N°2 Snodi

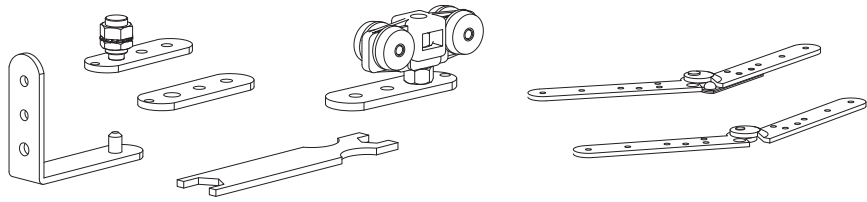

| OLD CODE | NEW CODE |  |  |
|-----------|------------|---|---|
| 1133-1137 | K.0211.1.1 | With hinges / Con cardini | 5x |

 **40 kg**

 N°3 Hinges **ART.1751**
N°3 Cerniere **ART.1751**

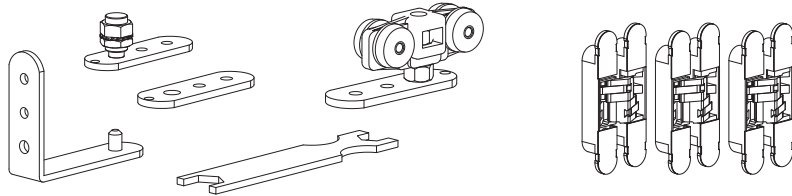

| OLD CODE | NEW CODE |  |  |
|-------------|------------|---|---|
| 1133/1751/N | K.0211.2.1 | With hinges / Con cerniere | 5x |

 **40 kg**

 N°3 Hinges **ART.1753**
N°3 Cerniere **ART.1753**

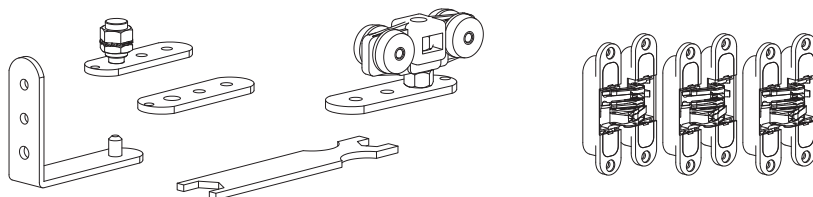

| OLD CODE | NEW CODE |  |  |
|-------------|------------|---|---|
| 1133/1753/N | K.0211.3.1 | With hinges / Con cerniere | 5x |

 **40 kg**

 N°3 Hinges **ART.1755**
N°3 Cerniere **ART.1755**

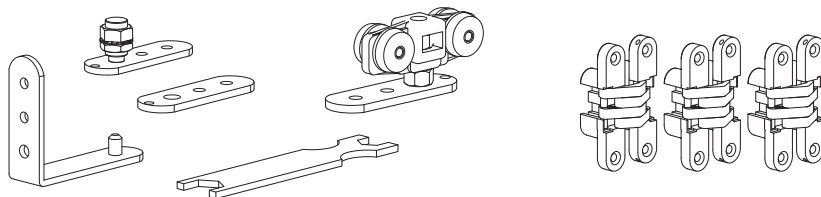

| OLD CODE | NEW CODE |  |  |
|-------------|------------|---|---|
| 1133/1755/N | K.0211.4.1 | With hinges / Con cerniere | 5x |

 **40 kg**

 N°3 Hinges **ART.1757**
N°3 Cerniere **ART.1757**

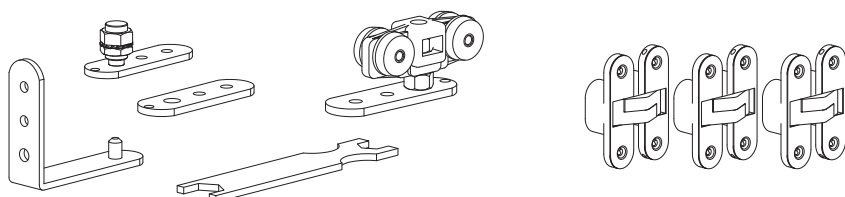

| OLD CODE | NEW CODE |  |  |
|--------------|------------|---|---|
| 1133/1757/PI | K.0211.5.1 | With hinges / Con cerniere | 5x |



FOLDING DOORS WITH EQUALLY SPACED PANELS
PORTE A LIBRO CON ANTE PARI DISTANZIATE

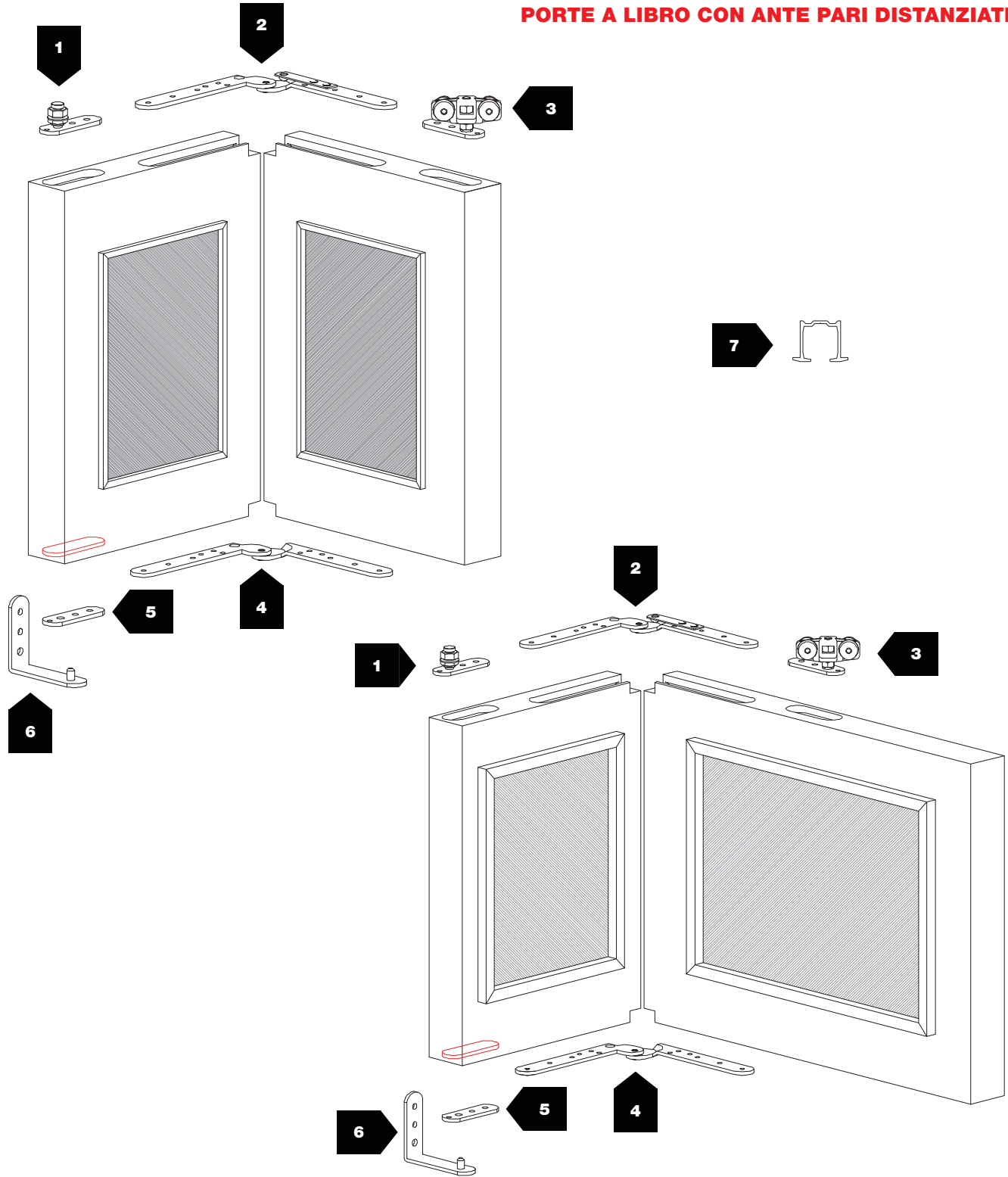





FOLDING DOORS WITH EQUALLY SPACED PANELS
PORTE A LIBRO CON ANTE DISUGUALI DISTANZIATE

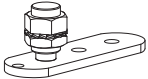
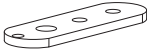

Min. 32 mm

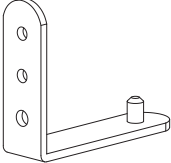
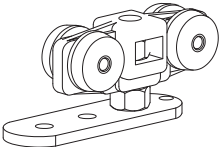
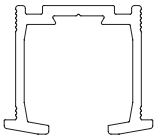
30 ÷ 40 kg

5 mm

| N° | Barcode | | kg | | N° | Barcode | | kg | |
|----|---------|---|-------|--|----|--------------------------------------|---|-------|--|
| 1 | 1133 |  | 30÷40 | | 5 | 1136 |  | 30÷40 | |
| 2 | 1145 |  | 30÷40 | | 6 | 1144 |  | 30÷40 | |
| 3 | 1137 |  | 30÷40 | | 7 | 2670 8 00 0.02670 8 01 0.02670 |  | — | |
| 4 | 1148 |  | 30÷40 | | | | | | |

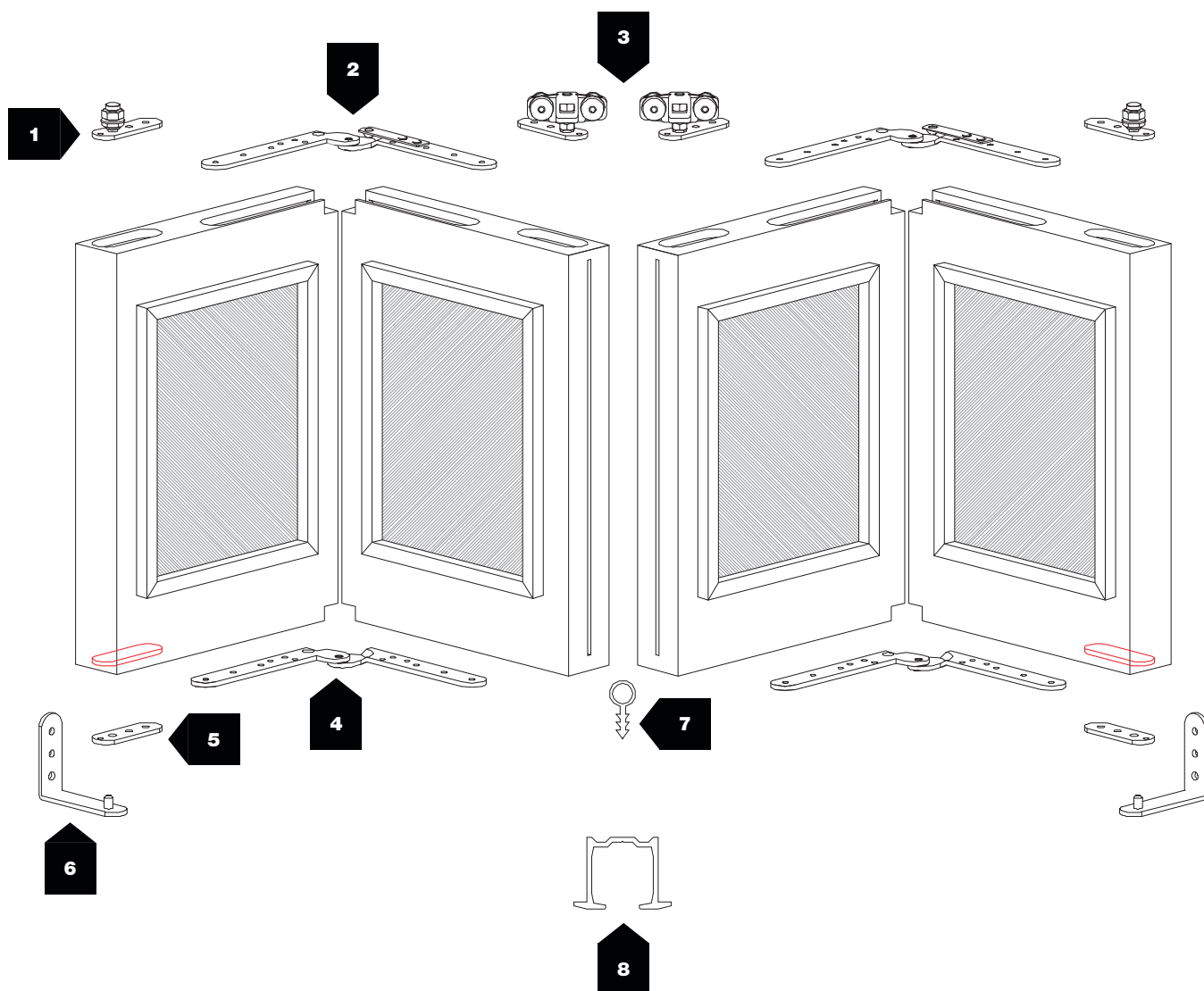
**TWO FOLDING DOORS
DUE PORTE A LIBRO**







Min. 32 mm



30 ÷ 40 kg

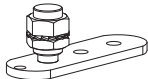
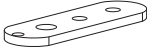

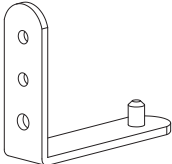
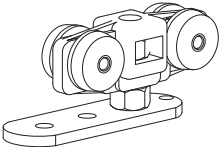
5 mm

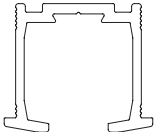
| N° | Barcode | | kg | N° | Barcode | | kg |
|----|---------|---|-------|----|--------------------------------------|---|-------|
| 1 | 1133 |  | 30÷40 | 5 | 1136 |  | 30÷40 |
| 2 | 1145 |  | 30÷40 | 6 | 1144 |  | 30÷40 |
| 3 | 1137 |  | 30÷40 | 7 | 894 |  | 30÷40 |
| 4 | 1148 |  | 30÷40 | 8 | 2670 8 00 0.02670 8 01 0.02670 |  | — |



30 kg



N°2 Junctions
N°2 Snodi

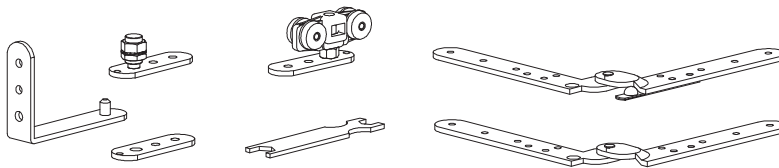

| OLD CODE | NEW CODE |  |  |
|-----------|------------|---|---|
| 1145-1148 | K.0213.1.1 | With hinges / Con cardini | 5x |



Gelosie Scorrevoli

Accessories for sliding shutters
Accessori per gelosie scorrevoli

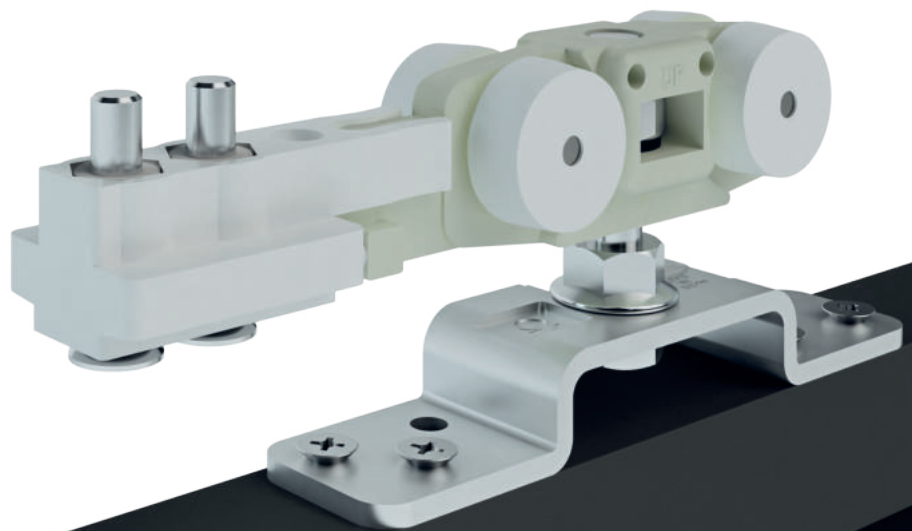





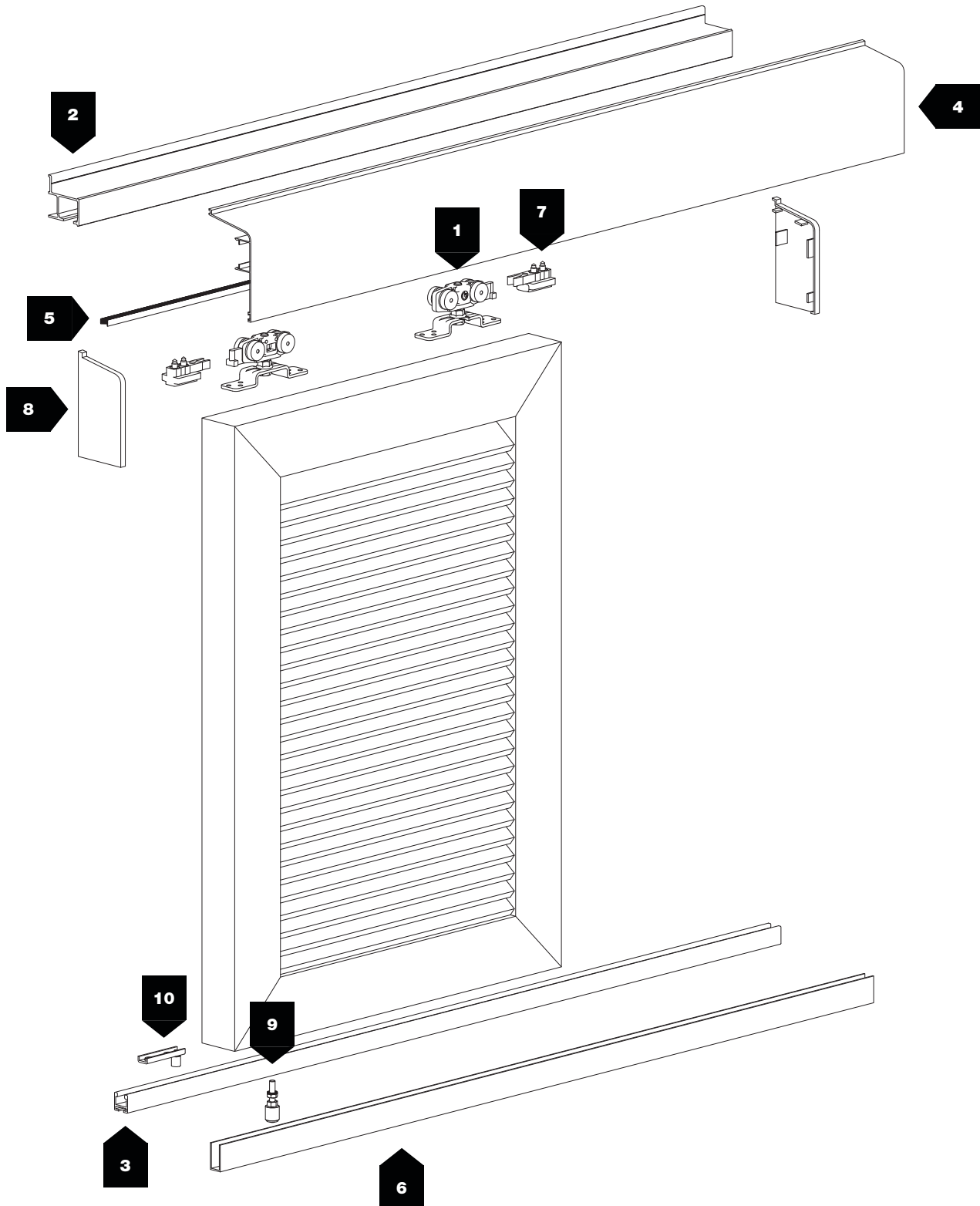

Gelosie Scorrevoli

Sliding shutters
Gelosie scorrevoli



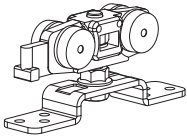
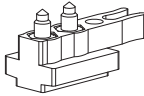
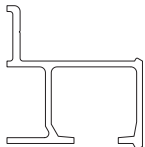
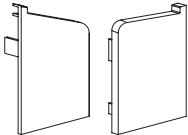
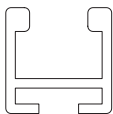
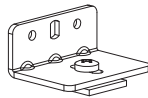
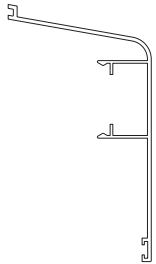

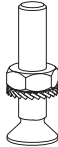
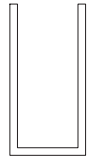
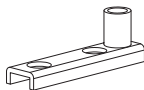
50 mm

80 kg

| N° | Barcode | | kg | | N° | Barcode | | kg | |
|----|-----------------------|---|----|------|---------------------|---|---|------------|------------|
| 1 | 56 S.56 |  | 80 | INOX | 7 | 53 S.53 |  | 80 | INOX |
| 2 | 204 8 01 0.00204 |  | — | | 8 | 207 C.207/KIT |  | — | |
| 3 | 220 8 01 0.00220 |  | — | | 9 | 128/PV/8 S.128/PV/8 |  | 80 | OPTIONAL + |
| 4 | 210 8 01 0.00210 |  | — | | | 51 S.51 |  | — | INOX |
| 5 | 760/N 8 14 0.00760 |  | — | | 226 S.226 |  | — | INOX | |
| 6 | 228 8 01 0.00228 |  | — | | 124 S.124 |  | 80 | INOX | |
| | | | | | 543 8 23 0.00543 |  | — | OPTIONAL + | |

| Tracks / Binari | | ALUMINUM FINISHES CODES / CODICI FINITURE ALLUMINIO | |  |
|-----------------|------|---|--|---|
| CODE / CODICE | | FINISH COLOR / COLORE FINITURA | | |
| 8 01 0.0 | 01 A | Anodized Silver / Argento | | STANDARD |

| Tracks / Binari | | PLASTIC FINISHES CODES / CODICI FINITURE PLASTICA | |  |
|-----------------|------|---|--|---|
| CODE / CODICE | | FINISH COLOR / COLORE FINITURA | | |
| 8 14 0.0 | 14 N | Anodized Black / Nero | | STANDARD |

| Accessories / Accessori | | PLASTIC FINISHES CODES / CODICI FINITURE PLASTICA | | |
|-------------------------|-------|---|--|----------|
| CODE / CODICE | | FINISH COLOR / COLORE FINITURA | | |
| 8 23 0.0 | 23 GR | Gray / Grigio | | STANDARD |

MEASUREMENTS DESCRIPTION / DESCRIZIONI MISURE

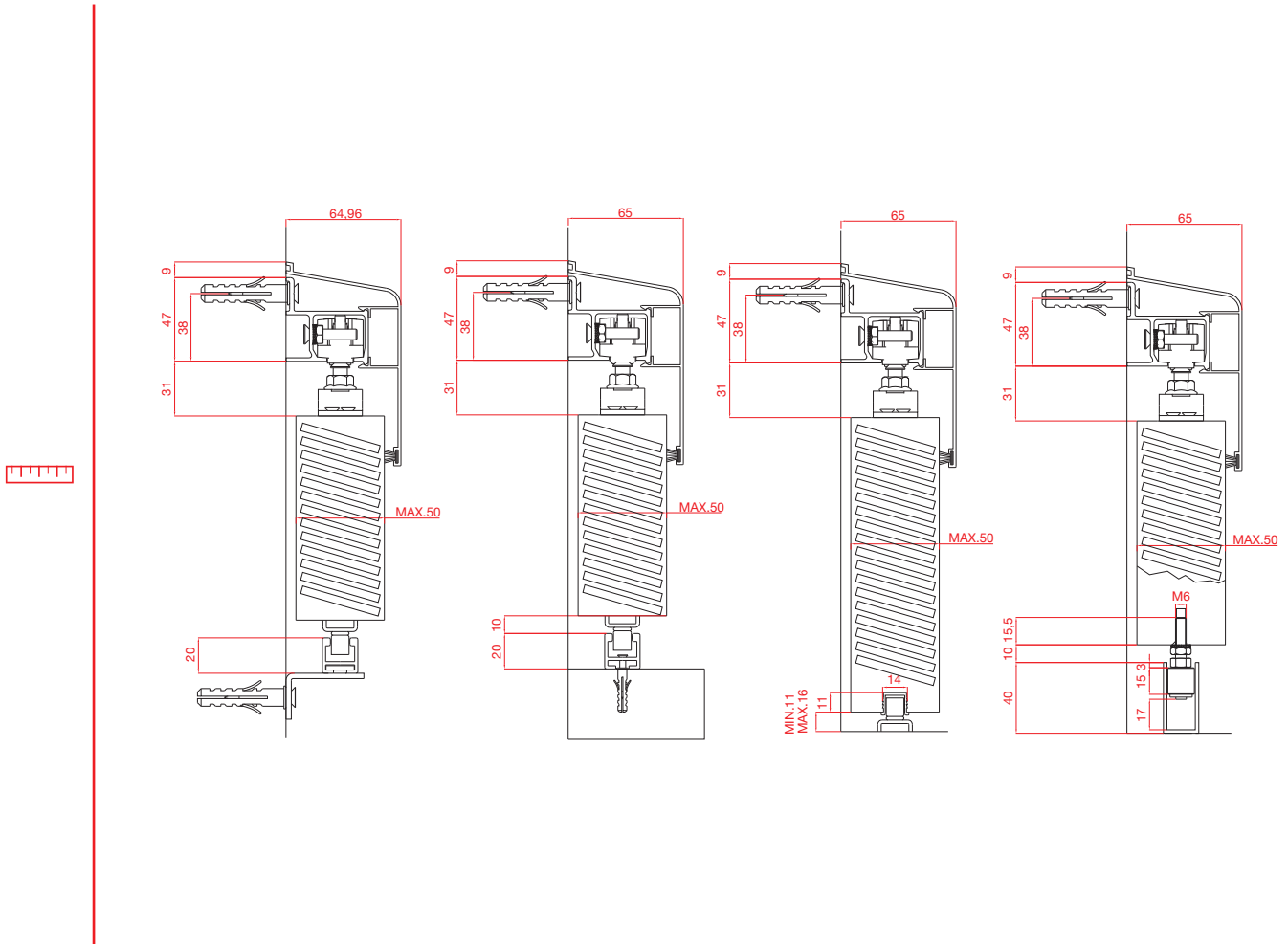

ACCESSORIES FOR SLIDING SHUTTER / ACCESSORI PER GELOSIA SCORREVOLE

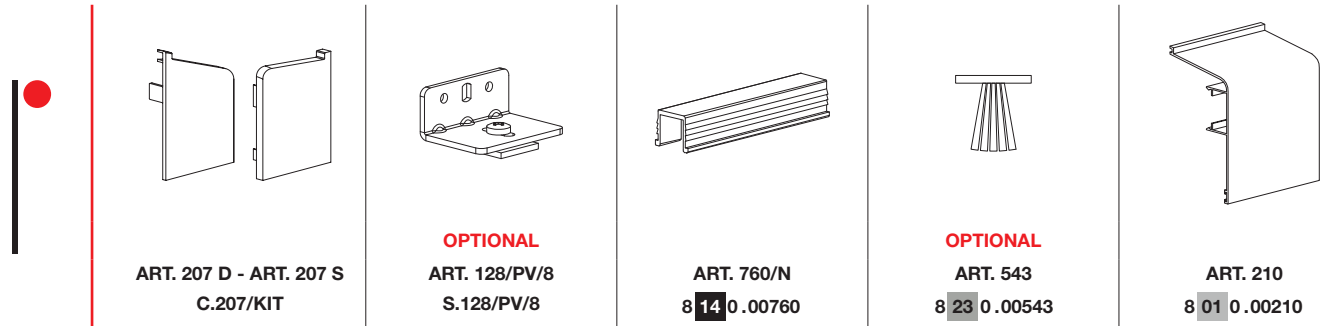

ACCESSORIES FOR SLIDING SHUTTER / ACCESSORI PER GELOSIA SCORREVOLE

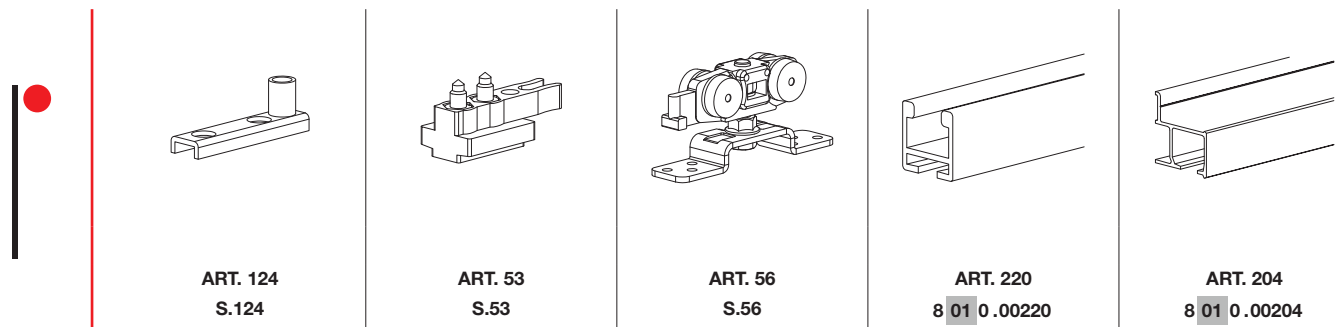



Hide

Slides with hidden bracket
Scorrevoli con staffa a scomparsa



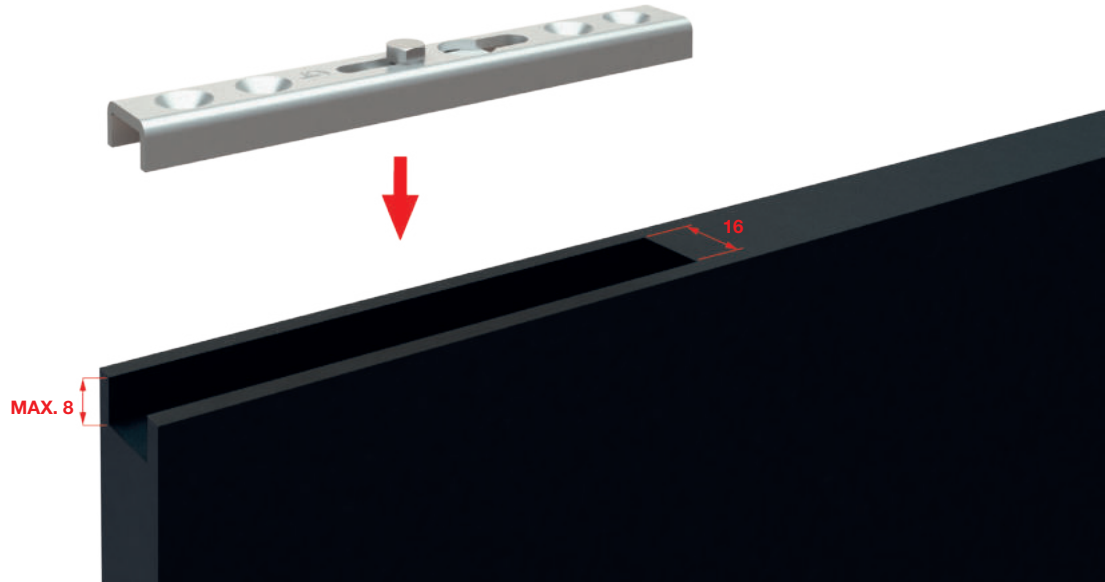
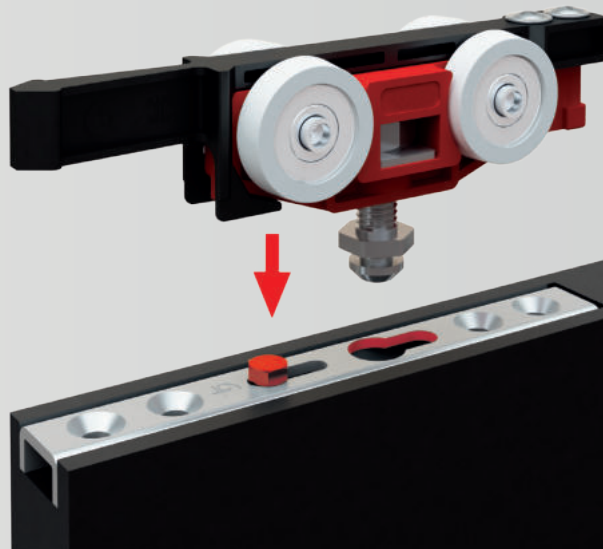
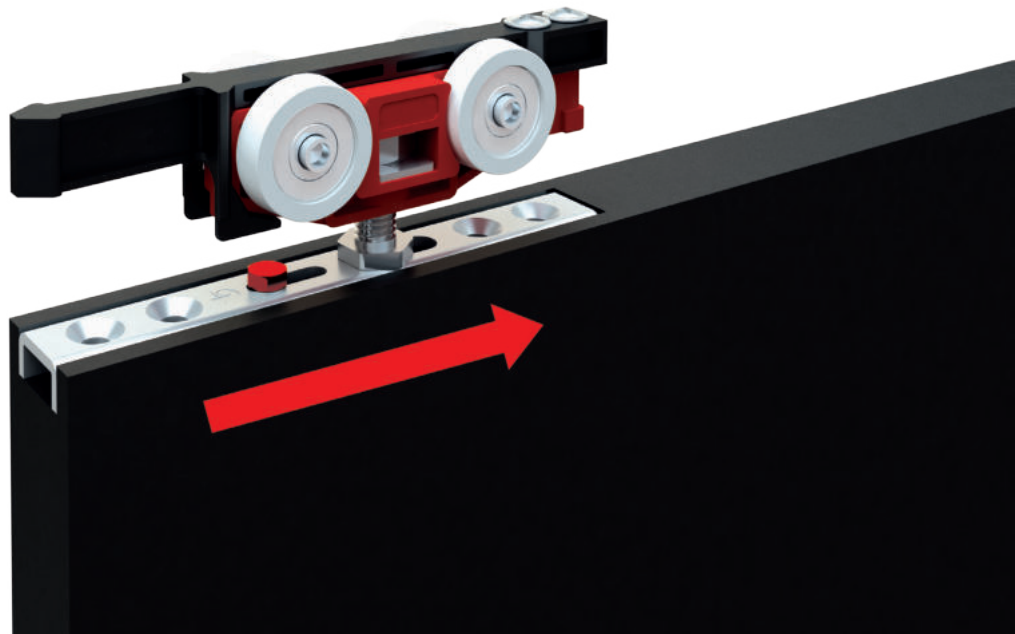

Easy mounting Facile da montare

1**Milled
Fresata****2****Insert trolley
Inserire il
carrello****3****Lock it
Bloccare**

4 Lock it
Bloccare

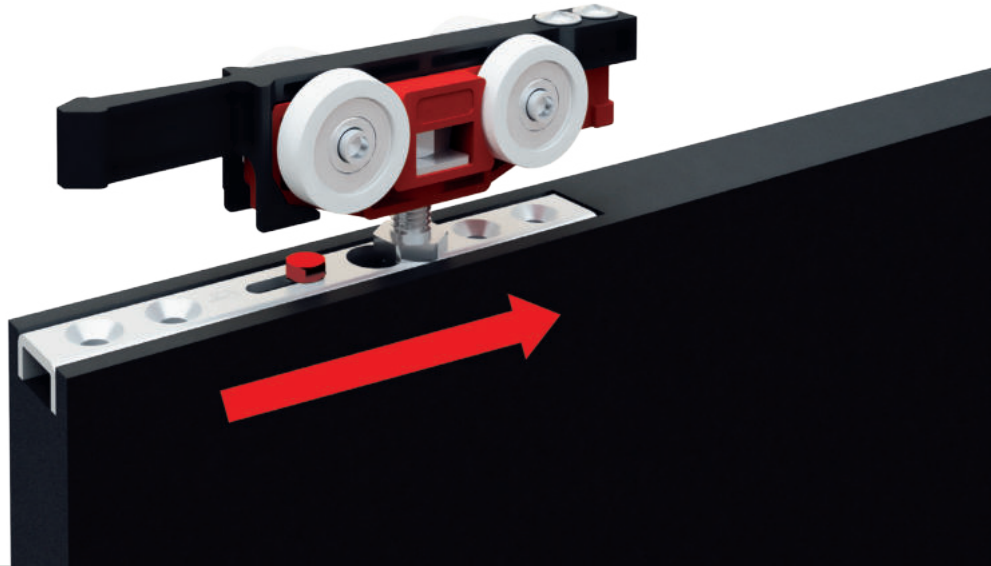

5 Fix
Fissaggio

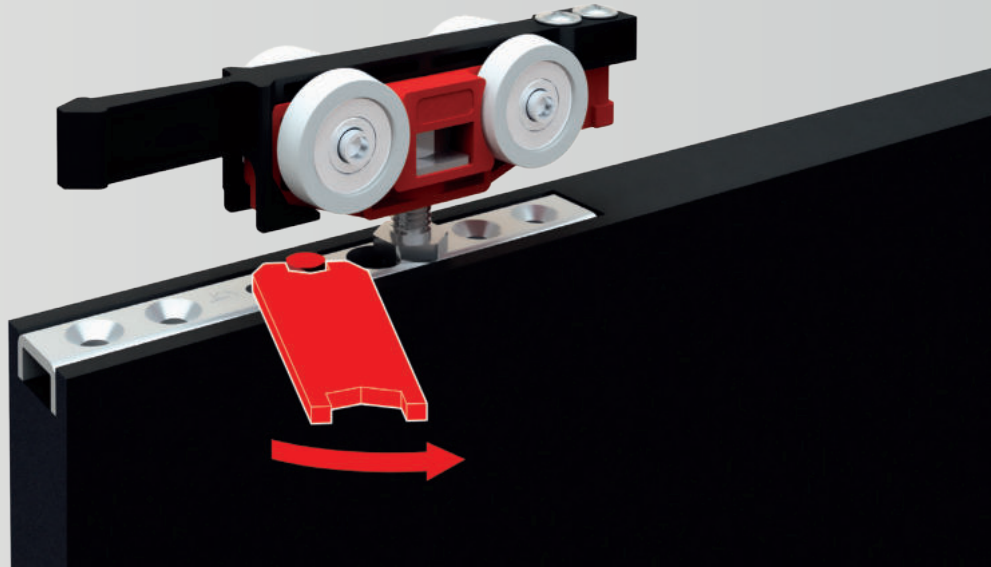

6 Adjusting
Regolazione

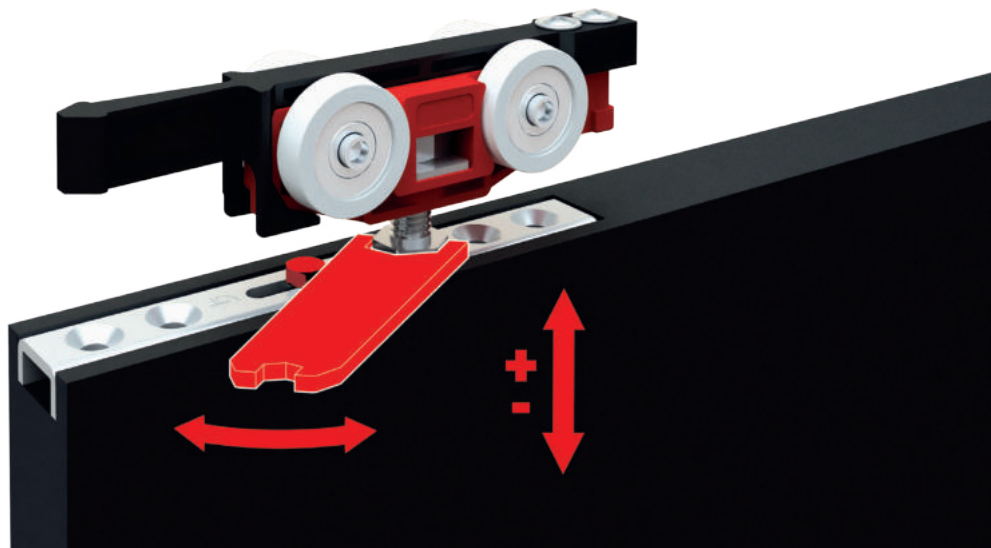

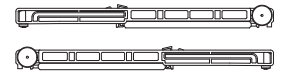
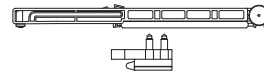





















**N.2 STANDARD STOPPERS
N.2 FERMI STANDARD**

**N.1 SOFT DAMPER STOPPER +
N.1 STANDARD STOPPER
N.1 FERMO AMMORTIZZATO +
N.1 FERMO STANDARD**

**N.2 SOFT DAMPER STOPPERS
N.2 FERMI AMMORTIZZATI**

| | | | |
|--|--|---|--|
|  <p>30 kg</p> |   Min. 600 mm PAG. 12 |   Min. 600 mm PAG. 12 |   Min. 600 mm PAG. 12 |
|  <p>50 kg</p> | | | |
|  <p>80 kg</p> |   Min. 600 mm PAG. 15 | | |
|  <p>120 kg</p> | | | |
|  <p>160 kg</p> |   Min. 700 mm PAG. 17 | | |
|  <p>180 kg</p> | | | |
|  <p>240 kg</p> |   Min. 700 mm PAG. 18 | | |
|  <p>250 kg</p> | | | |

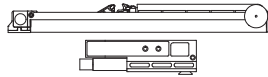
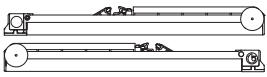

























N.2 FLUID DAMPERS
N.2 FERMI AMMORTIZZATI FLUID

N.1 FLUID DAMPER + N.1 SHOCK ABSORBER
N.1 FERMO AMMORTIZZATO FLUID + N.1 FERMO A PINZA AMMORTIZZATO

N.2 SHOCK ABSORBERS
N.2 FERMI A PINZA AMMORTIZZATI

N.2 HYDRAULIC STOPPERS (NAVAL SECTOR)
N.2 FERMI IDRAULICI (SETTORE NAVALE)

| | | | |
|---|---|---|--|
| | | | |
|  NEW  Min. 810 mm PAG. 13 |  NEW  Min. 600 mm PAG. 13 |  NEW  Min. 600 mm PAG. 13 | |
|  NEW  Min. 810 mm PAG. 14 |  NEW  Min. 600 mm PAG. 14 |  NEW  Min. 600 mm PAG. 14 |   Min. 700 mm PAG. 15 |
|  NEW  Min. 810 mm PAG. 16 |  NEW  Min. 600 mm PAG. 16 |  NEW  Min. 600 mm PAG. 16 | |
| | |  NEW  Min. 700 mm PAG. 17 | |
| | |  NEW  Min. 700 mm PAG. 18 | |

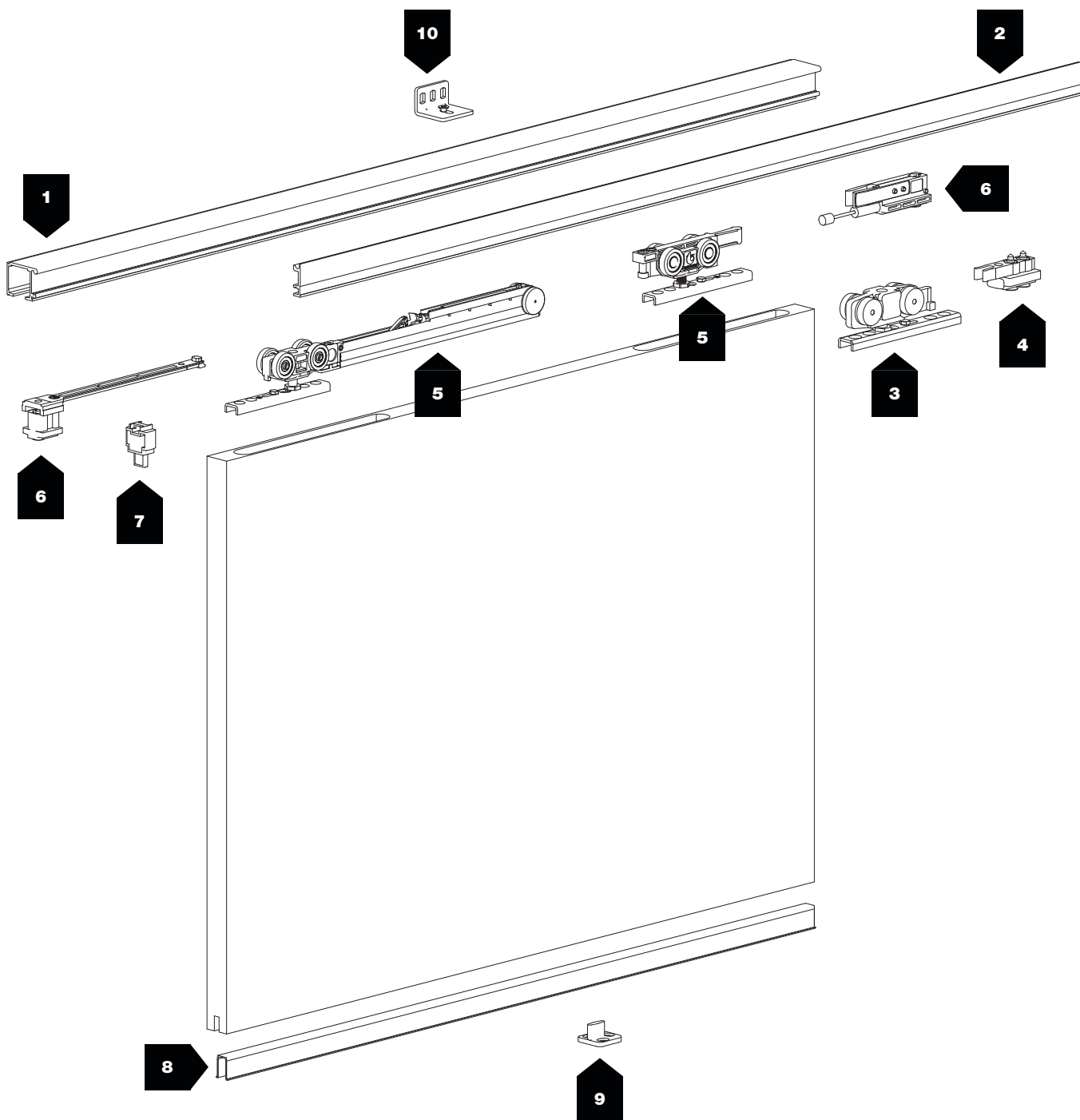







600 ÷ 1500 mm



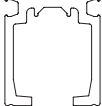
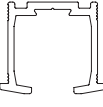
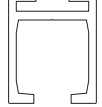
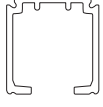
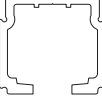
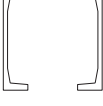
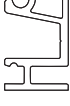
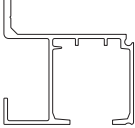

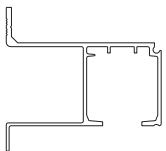



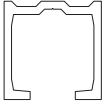
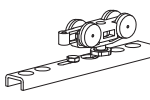
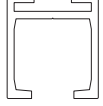
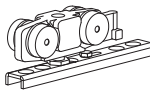
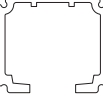
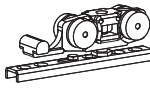

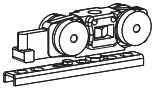
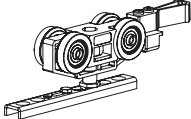
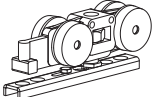
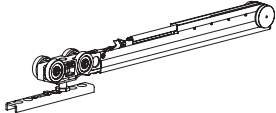
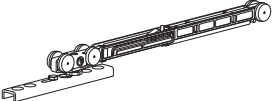
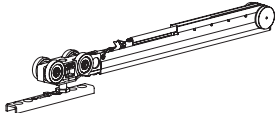

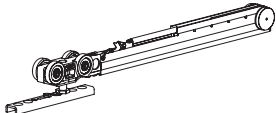
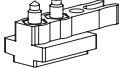
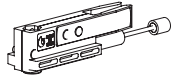
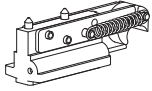
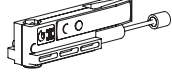

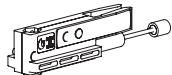
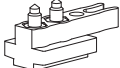
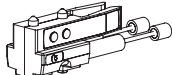

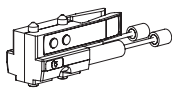
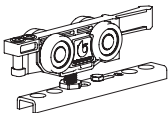
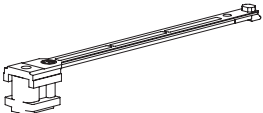



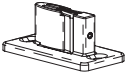

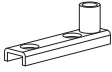

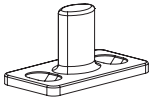
30 ÷ 250 kg

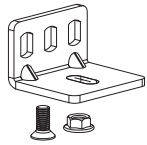

6 ÷ 15 mm

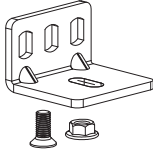
| N° | Barcode | Image | kg | Category | N° | Barcode | Image | kg | Category | |
|----|--------------------------------------|---|----|------------|----|--------------------------------------|---|---|------------------------|--------------------------|
| 1 | 2660 8 00 0.02660 8 01 0.02660 |  | - | STANDARD | 1 | 3480 8 00 0.03480 8 01 0.03480 |  | - | STANDARD NEW | |
| | 2670 8 00 0.02670 8 01 0.02670 |  | - | OPTIONAL + | | 201 8 00 0.00201 8 01 0.00201 |  | - | STANDARD | |
| | 1280 8 00 0.01280 8 01 0.01280 |  | - | STANDARD | | 234 8 00 0.00234 8 01 0.00234 |  | - | OPTIONAL + | |
| | 1080 8 00 0.01080 8 01 0.01080 |  | - | OPTIONAL + | | 1710 8 00 0.01710 8 01 0.01710 |  | - | OPTIONAL + | |
| | 1359 8 00 0.01359 8 01 0.01359 |  | - | OPTIONAL + | | 1720 8 00 0.01720 8 01 0.01720 |  | - | OPTIONAL + | |
| | 1559 8 00 0.01559 8 01 0.01559 |  | - | OPTIONAL + | | 2 | 3490 8 02 0.03490 |  | - | OPTIONAL + NEW |
| | 1700 8 00 0.01700 8 01 0.01700 |  | - | OPTIONAL + | | | 3491 |  | - | OPTIONAL + NEW |
| | 1160 8 00 0.01160 8 01 0.01160 |  | - | STANDARD | | | 2669/T |  | 30 | |
| | 160 8 00 0.00160 8 01 0.00160 |  | - | OPTIONAL + | | 3 | 82/T |  | 80 | |
| | 1660 8 00 0.01660 8 01 0.01660 |  | - | OPTIONAL + | | | 1646/T |  | 80 | |

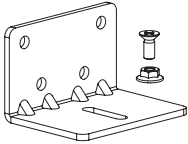
| N° | | | kg | | N° | | | kg | |
|----|---------|---|--------|--------------|----------|---|---|--------------|--------------|
| 3 | 1162/T |  | 160 | | 5 | 3528 |  | 180÷250 | FLUID NEW |
| | 206/T |  | 240 | | | 3392/050 |  | 50 | FLUID NEW |
| | 2668/T |  | 30 | | | 3392/080 |  | 80 | FLUID NEW |
| 4 | 2657 |  | 30 | | 3392/120 |  | 120 | FLUID NEW | |
| | 84 |  | 80 | | 3355/050 |  | 50 | FLUID NEW | |
| | 1627/10 |  | 80 | | 3355/080 |  | 80 | FLUID NEW | |
| | 1163 |  | 160 | | 3355/120 |  | 120 | FLUID NEW | |
| | 1165 |  | 240 | | 3485/180 |  | 180 | FLUID NEW | |
| | 2661 |  | 30 | | 3485/250 |  | 250 | FLUID NEW | |
| | 3393 |  | 50÷120 | FLUID NEW | 3354 |  | 50÷120 | FLUID NEW | |

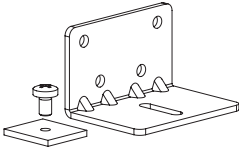
| N° | Barcode | | kg | | N° | Barcode | | kg | |
|----|-------------------------------------|---|---------|------------|----|---------|---|---------|------------|
| 7 | 3347 |  | — | | 90 | |  | 30÷120 | OPTIONAL + |
| 8 | 121 8 23 0.00121 |  | 30÷120 | OPTIONAL + | 9 | 124 |  | 160÷240 | |
| | 705 8 23 0.00705 |  | 50÷120 | OPTIONAL + | | 2855 |  | 180÷250 | NEW |
| | 707 8 00 0.00707 8 01 0.00707 |  | 50÷120 | OPTIONAL + | | 409 |  | — | |
| | 760/N 8 14 0.00760 |  | 160÷240 | | | 126 |  | 30 | |
| 9 | 1032 |  | 30 | | 10 | 127/D/V |  | 50÷120 | |
| | 45 |  | 50÷80 | | | 163/DV |  | 160÷250 | |
| | 93 |  | 120 | | | 163/PV |  | 160÷250 | |

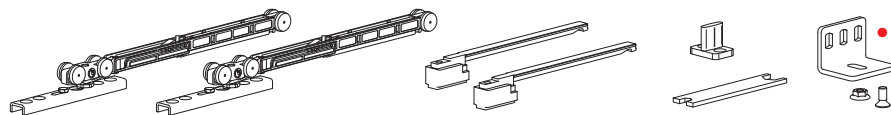

ART. 2660
(8000.02660)
(8010.02660)



30 kg



N.2 Soft damper stoppers
N.2 Fermi ammortizzati



Turned wheels
Ruote tornite

| | | | OLD CODE | NEW CODE | | TRACK-BINARIO | |
|----------------|---|------|----------------|----------------|----------------|-------------------|----|
| KIT | • | N° 3 | 2668/2668/G/C | K.030.6.5.C | Min. 600 mm | — | 4x |
| | | — | 2668/2668/G/S | K.030.6.5.S | Min. 600 mm | — | 4x |
| BLISTER | • | N° 4 | 2668/2668/150C | B.030.6.5.C150 | 700 ÷ 850 mm | 1500 mm | 4x |
| | | N° 5 | 2668/2668/165C | B.030.6.5.C165 | 860 ÷ 950 mm | 1650 mm | 4x |
| | | N° 5 | 2668/2668/200C | B.030.6.5.C200 | 960 ÷ 1100 mm | 2000 mm | 4x |
| | | N° 6 | 2668/2668/250C | B.030.6.5.C250 | 1110 ÷ 1350 mm | 2500 mm | 4x |
| | | N° 7 | 2668/2668/300C | B.030.6.5.C300 | 1360 ÷ 1600 mm | 3000 mm | 4x |
| | | — | 2668/2668/150S | B.030.6.5.S150 | 700 ÷ 850 mm | 1500 mm | 4x |
| | | — | 2668/2668/165S | B.030.6.5.S165 | 860 ÷ 950 mm | 1650 mm | 4x |
| | | — | 2668/2668/200S | B.030.6.5.S200 | 960 ÷ 1100 mm | 2000 mm | 4x |
| | | — | 2668/2668/250S | B.030.6.5.S250 | 1110 ÷ 1350 mm | 2500 mm | 4x |
| | | — | 2668/2668/300S | B.030.6.5.S300 | 1360 ÷ 1600 mm | 3000 mm | 4x |

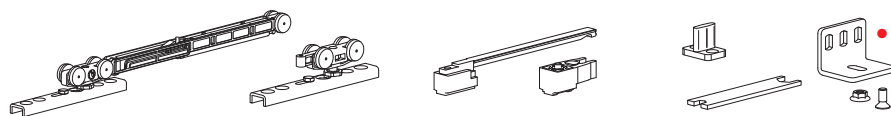

ART. 2660
(8000.02660)
(8010.02660)



30 kg



N.1 Soft damper stopper
N.1 Fermo ammortizzato



N.1 Standard stopper
N.1 Fermo standard



Turned wheels
Ruote tornite

| | | | OLD CODE | NEW CODE | | TRACK-BINARIO | |
|----------------|---|------|----------------|----------------|----------------|-------------------|----|
| KIT | • | N° 3 | 2668/2669/G/C | K.030.5.5.C | Min. 600 mm | — | 4x |
| | | — | 2668/2669/G/S | K.030.5.5.S | Min. 600 mm | — | 4x |
| BLISTER | • | N° 4 | 2668/2669/150C | B.030.5.5.C150 | 700 ÷ 850 mm | 1500 mm | 4x |
| | | N° 5 | 2668/2669/165C | B.030.5.5.C165 | 860 ÷ 950 mm | 1650 mm | 4x |
| | | N° 5 | 2668/2669/200C | B.030.5.5.C200 | 960 ÷ 1100 mm | 2000 mm | 4x |
| | | N° 6 | 2668/2669/250C | B.030.5.5.C250 | 1110 ÷ 1350 mm | 2500 mm | 4x |
| | | N° 7 | 2668/2669/300C | B.030.5.5.C300 | 1360 ÷ 1600 mm | 3000 mm | 4x |
| | | — | 2668/2669/150S | B.030.5.5.S150 | 700 ÷ 850 mm | 1500 mm | 4x |
| | | — | 2668/2669/165S | B.030.5.5.S165 | 860 ÷ 950 mm | 1650 mm | 4x |
| | | — | 2668/2669/200S | B.030.5.5.S200 | 960 ÷ 1100 mm | 2000 mm | 4x |
| | | — | 2668/2669/250S | B.030.5.5.S250 | 1110 ÷ 1350 mm | 2500 mm | 4x |
| | | — | 2668/2669/300S | B.030.5.5.S300 | 1360 ÷ 1600 mm | 3000 mm | 4x |

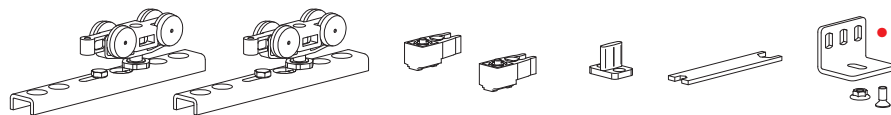

ART. 2660
(8000.02660)
(8010.02660)



30 kg



N.2 Standard stoppers
N.2 Fermi standard



Turned wheels
Ruote tornite

| | | | OLD CODE | NEW CODE | | TRACK-BINARIO | |
|----------------|---|------|----------------|----------------|----------------|-------------------|----|
| KIT | • | N° 3 | 2669/2669/G/C | K.030.0.5.C | Min. 600 mm | — | 5x |
| | | — | 2669/2669/G/S | K.030.0.5.S | Min. 600 mm | — | 5x |
| BLISTER | • | N° 4 | 2669/2669/150S | B.030.0.5.C150 | 700 ÷ 850 mm | 1500 mm | 4x |
| | | N° 5 | 2669/2669/165C | B.030.0.5.C165 | 860 ÷ 950 mm | 1650 mm | 4x |
| | | N° 5 | 2669/2669/200C | B.030.0.5.C200 | 960 ÷ 1100 mm | 2000 mm | 4x |
| | | N° 6 | 2669/2669/250C | B.030.0.5.C250 | 1110 ÷ 1350 mm | 2500 mm | 4x |
| | | N° 7 | 2669/2669/300C | B.030.0.5.C300 | 1360 ÷ 1600 mm | 3000 mm | 4x |
| | | — | 2669/2669/150S | B.030.0.5.S150 | 700 ÷ 850 mm | 1500 mm | 4x |
| | | — | 2669/2669/165S | B.030.0.5.S165 | 860 ÷ 950 mm | 1650 mm | 4x |
| | | — | 2669/2669/200S | B.030.0.5.S200 | 960 ÷ 1100 mm | 2000 mm | 4x |
| | | — | 2669/2669/250S | B.030.0.5.S250 | 1110 ÷ 1350 mm | 2500 mm | 4x |
| | | — | 2669/2669/300S | B.030.0.5.S300 | 1360 ÷ 1600 mm | 3000 mm | 4x |

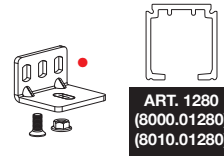
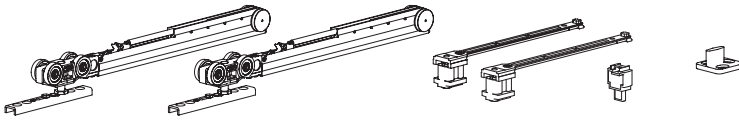

| | | OLD CODE | NEW CODE | | TRACK-BINARIO | |
|----------------|---|----------|----------|-----------------------|-------------------|---------|
| KIT | ● | N° 4 | — | K.050.2.5.C | Min. 810 mm | — |
| | | — | — | K.050.2.5.S | Min. 810 mm | — |
| BLISTER | ● | N° 4 | — | B.050.2.5.C150 | 810 ÷ 850 mm | 1500 mm |
| | | N° 5 | — | B.050.2.5.C165 | 860 ÷ 950 mm | 1650 mm |
| | | N° 5 | — | B.050.2.5.C200 | 960 ÷ 1100 mm | 2000 mm |
| | | N° 6 | — | B.050.2.5.C250 | 1110 ÷ 1350 mm | 2500 mm |
| | | N° 7 | — | B.050.2.5.C300 | 1360 ÷ 1600 mm | 3000 mm |
| | | — | — | B.050.2.5.S150 | 700 ÷ 850 mm | 1500 mm |
| | | — | — | B.050.2.5.S165 | 860 ÷ 950 mm | 1650 mm |
| | | — | — | B.050.2.5.S200 | 960 ÷ 1100 mm | 2000 mm |
| | | — | — | B.050.2.5.S250 | 1110 ÷ 1350 mm | 2500 mm |
| | | — | — | B.050.2.5.S300 | 1360 ÷ 1600 mm | 3000 mm |

50 kg

N.2 Fluid dampers
 N.2 Fermi ammortizzati
FLUID Fluid

Ball bearings
Cuscinetti a sfera

FLUID

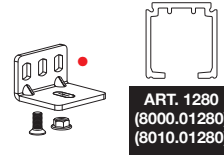
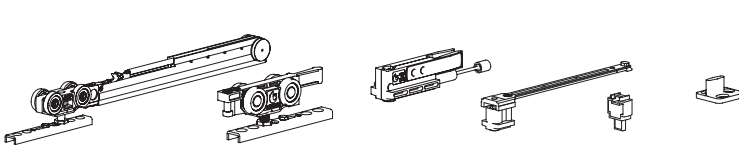

| | | OLD CODE | NEW CODE | | TRACK-BINARIO | |
|----------------|---|----------|----------|-----------------------|-------------------|---------|
| KIT | ● | N° 4 | — | K.050.1.5.C | Min. 600 mm | — |
| | | — | — | K.050.1.5.S | Min. 600 mm | — |
| BLISTER | ● | N° 4 | — | B.050.1.5.C150 | 700 ÷ 850 mm | 1500 mm |
| | | N° 5 | — | B.050.1.5.C165 | 860 ÷ 950 mm | 1650 mm |
| | | N° 5 | — | B.050.1.5.C200 | 960 ÷ 1100 mm | 2000 mm |
| | | N° 6 | — | B.050.1.5.C250 | 1110 ÷ 1350 mm | 2500 mm |
| | | N° 7 | — | B.050.1.5.C300 | 1360 ÷ 1600 mm | 3000 mm |
| | | — | — | B.050.1.5.S150 | 700 ÷ 850 mm | 1500 mm |
| | | — | — | B.050.1.5.S165 | 860 ÷ 950 mm | 1650 mm |
| | | — | — | B.050.1.5.S200 | 960 ÷ 1100 mm | 2000 mm |
| | | — | — | B.050.1.5.S250 | 1110 ÷ 1350 mm | 2500 mm |
| | | — | — | B.050.1.5.S300 | 1360 ÷ 1600 mm | 3000 mm |

50 kg

N.1 Fluid damper
 N.1 Fermo ammortizzato
FLUID Fluid

N.1 Shock absorber
 N.1 Fermo a pinza ammortizzato

Ball bearings
Cuscinetti a sfera

FLUID

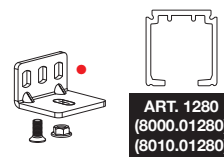
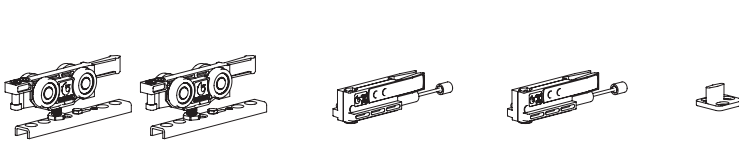

| | | OLD CODE | NEW CODE | | TRACK-BINARIO | |
|----------------|---|----------|----------|-----------------------|-------------------|---------|
| KIT | ● | N° 4 | — | K.050.3.5.C | Min. 600 mm | — |
| | | — | — | K.050.3.5.S | Min. 600 mm | — |
| BLISTER | ● | N° 4 | — | B.050.3.5.C150 | 700 ÷ 850 mm | 1500 mm |
| | | N° 5 | — | B.050.3.5.C165 | 860 ÷ 950 mm | 1650 mm |
| | | N° 5 | — | B.050.3.5.C200 | 960 ÷ 1100 mm | 2000 mm |
| | | N° 6 | — | B.050.3.5.C250 | 1110 ÷ 1350 mm | 2500 mm |
| | | N° 7 | — | B.050.3.5.C300 | 1360 ÷ 1600 mm | 3000 mm |
| | | — | — | B.050.3.5.S150 | 700 ÷ 850 mm | 1500 mm |
| | | — | — | B.050.3.5.S165 | 860 ÷ 950 mm | 1650 mm |
| | | — | — | B.050.3.5.S200 | 960 ÷ 1100 mm | 2000 mm |
| | | — | — | B.050.3.5.S250 | 1110 ÷ 1350 mm | 2500 mm |
| | | — | — | B.050.3.5.S300 | 1360 ÷ 1600 mm | 3000 mm |

50 kg

N.2 Shock absorber
 N.2 Fermi a pinza ammortizzati

Ball bearings
Cuscinetti a sfera

FLUID

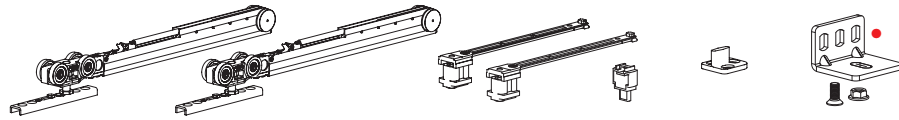

FLUID



80 kg



N.2 Fluid dampers
N.2 Fermi ammortizzati
Fluid



Ball bearings
Cuscinetti a sfera

| | | | OLD CODE | NEW CODE | | TRACK-BINARIO | |
|----------------|---|------|----------|-----------------------|----------------|---------------|----|
| KIT | ● | N° 5 | — | K.080.2.5.C | Min. 810 mm | — | 4x |
| | | — | — | K.080.2.5.S | Min. 810 mm | — | 4x |
| BLISTER | ● | N° 4 | — | B.080.2.5.C150 | 810 ÷ 850 mm | 1500 mm | 4x |
| | | N° 5 | — | B.080.2.5.C165 | 860 ÷ 950 mm | 1650 mm | 4x |
| | | N° 5 | — | B.080.2.5.C200 | 960 ÷ 1100 mm | 2000 mm | 4x |
| | | N° 6 | — | B.080.2.5.C250 | 1110 ÷ 1350 mm | 2500 mm | 4x |
| | | N° 7 | — | B.080.2.5.C300 | 1360 ÷ 1600 mm | 3000 mm | 4x |
| | ● | — | — | B.080.2.5.S150 | 700 ÷ 850 mm | 1500 mm | 4x |
| | | — | — | B.080.2.5.S165 | 860 ÷ 950 mm | 1650 mm | 4x |
| | | — | — | B.080.2.5.S200 | 960 ÷ 1100 mm | 2000 mm | 4x |
| | | — | — | B.080.2.5.S250 | 1110 ÷ 1350 mm | 2500 mm | 4x |
| | | — | — | B.080.2.5.S300 | 1360 ÷ 1600 mm | 3000 mm | 4x |

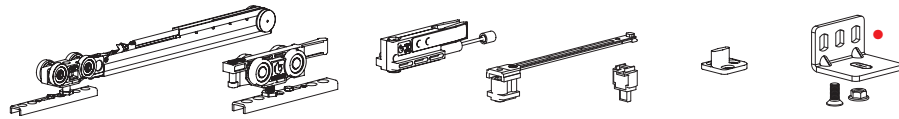

FLUID



80 kg



N.1 Fluid damper
N.1 Fermo ammortizzato
Fluid



N.1 Shock absorber
N.1 Fermo a pinza
ammortizzato



Ball bearings
Cuscinetti a sfera

| | | | OLD CODE | NEW CODE | | TRACK-BINARIO | |
|----------------|---|------|----------|-----------------------|----------------|---------------|----|
| KIT | ● | N° 5 | — | K.080.1.5.C | Min. 600 mm | — | 4x |
| | | — | — | K.080.1.5.S | Min. 600 mm | — | 4x |
| BLISTER | ● | N° 4 | — | B.080.1.5.C150 | 700 ÷ 850 mm | 1500 mm | 4x |
| | | N° 5 | — | B.080.1.5.C165 | 860 ÷ 950 mm | 1650 mm | 4x |
| | | N° 5 | — | B.080.1.5.C200 | 960 ÷ 1100 mm | 2000 mm | 4x |
| | | N° 6 | — | B.080.1.5.C250 | 1110 ÷ 1350 mm | 2500 mm | 4x |
| | | N° 7 | — | B.080.1.5.C300 | 1360 ÷ 1600 mm | 3000 mm | 4x |
| | ● | — | — | B.080.1.5.S150 | 700 ÷ 850 mm | 1500 mm | 4x |
| | | — | — | B.080.1.5.S165 | 860 ÷ 950 mm | 1650 mm | 4x |
| | | — | — | B.080.1.5.S200 | 960 ÷ 1100 mm | 2000 mm | 4x |
| | | — | — | B.080.1.5.S250 | 1110 ÷ 1350 mm | 2500 mm | 4x |
| | | — | — | B.080.1.5.S300 | 1360 ÷ 1600 mm | 3000 mm | 4x |

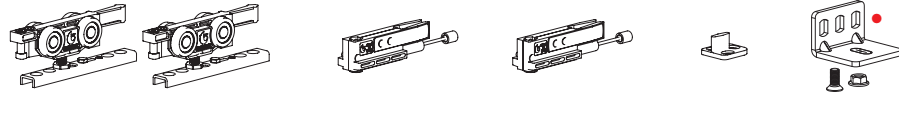

FLUID



80 kg



N.2 Shock absorber
N.2 Fermi a pinza
ammortizzati



Ball bearings
Cuscinetti a sfera

| | | | OLD CODE | NEW CODE | | TRACK-BINARIO | |
|----------------|---|------|----------|-----------------------|----------------|---------------|----|
| KIT | ● | N° 5 | — | K.080.3.5.C | Min. 600 mm | — | 5x |
| | | — | — | K.080.3.5.S | Min. 600 mm | — | 5x |
| BLISTER | ● | N° 4 | — | B.080.3.5.C150 | 700 ÷ 850 mm | 1500 mm | 4x |
| | | N° 5 | — | B.080.3.5.C165 | 860 ÷ 950 mm | 1650 mm | 4x |
| | | N° 5 | — | B.080.3.5.C200 | 960 ÷ 1100 mm | 2000 mm | 4x |
| | | N° 6 | — | B.080.3.5.C250 | 1110 ÷ 1350 mm | 2500 mm | 4x |
| | | N° 7 | — | B.080.3.5.C300 | 1360 ÷ 1600 mm | 3000 mm | 4x |
| | ● | — | — | B.080.3.5.S150 | 700 ÷ 850 mm | 1500 mm | 4x |
| | | — | — | B.080.3.5.S165 | 860 ÷ 950 mm | 1650 mm | 4x |
| | | — | — | B.080.3.5.S200 | 960 ÷ 1100 mm | 2000 mm | 4x |
| | | — | — | B.080.3.5.S250 | 1110 ÷ 1350 mm | 2500 mm | 4x |
| | | — | — | B.080.3.5.S300 | 1360 ÷ 1600 mm | 3000 mm | 4x |

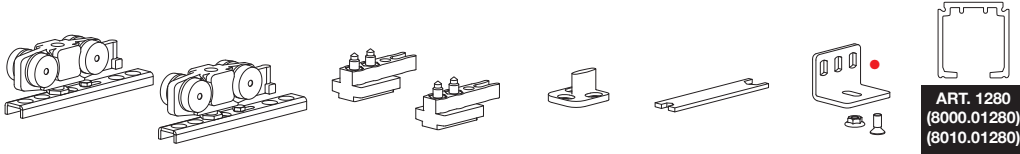

| | | N° | OLD CODE | NEW CODE | MIN | TRACK-BINARIO | |
|----------------|---|------|-----------------|----------------|----------------|---------------|-----|
| | | | | | | MIN | MIN |
| KIT | ● | N° 5 | 80/T/G/SC/CON | K.080.0.5.C | Min. 600 mm | — | 5x |
| | — | — | 80/T/G/SC/SEN | K.080.0.5.S | Min. 600 mm | — | 5x |
| BLISTER | ● | N° 4 | 80/T/P/SC150CON | B.080.0.5.C150 | 700 ÷ 850 mm | 1500 mm | 4x |
| | | N° 5 | 80/T/P/SC165CON | B.080.0.5.C165 | 860 ÷ 950 mm | 1650 mm | 4x |
| | | N° 5 | 80/T/P/SC200CON | B.080.0.5.C200 | 960 ÷ 1100 mm | 2000 mm | 4x |
| | | N° 6 | 80/T/P/SC250CON | B.080.0.5.C250 | 1110 ÷ 1350 mm | 2500 mm | 4x |
| | | N° 7 | 80/T/P/SC300CON | B.080.0.5.C300 | 1360 ÷ 1600 mm | 3000 mm | 4x |
| | — | — | 80/T/P/SC150SEN | B.080.0.5.S150 | 700 ÷ 850 mm | 1500 mm | 4x |
| | | — | 80/T/P/SC165SEN | B.080.0.5.S165 | 860 ÷ 950 mm | 1650 mm | 4x |
| | | — | 80/T/P/SC200SEN | B.080.0.5.S200 | 960 ÷ 1100 mm | 2000 mm | 4x |
| | | — | 80/T/P/SC250SEN | B.080.0.5.S250 | 1110 ÷ 1350 mm | 2500 mm | 4x |
| | | — | 80/T/P/SC300SEN | B.080.0.5.S300 | 1360 ÷ 1600 mm | 3000 mm | 4x |



80 kg



N.2 Standard stopper
N.2 Fermi standard



Turned wheels
Ruote tornite

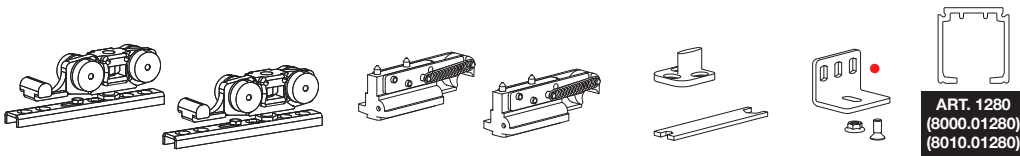

| | | N° | OLD CODE | NEW CODE | MIN | TRACK-BINARIO | |
|----------------|---|------|----------------|----------------|----------------|---------------|-----|
| | | | | | | MIN | MIN |
| KIT | ● | N° 5 | 80/TG/SC/C/FAN | K.080.4.5.C | Min. 700 mm | — | 5x |
| | — | — | 80/TG/SC/S/FAN | K.080.4.5.S | Min. 700 mm | — | 5x |
| BLISTER | ● | N° 4 | 80T/PSC150CFAN | B.080.4.5.C150 | 700 ÷ 850 mm | 1500 mm | 4x |
| | | N° 5 | 80T/PSC165CFAN | B.080.4.5.C165 | 860 ÷ 950 mm | 1650 mm | 4x |
| | | N° 5 | 80T/PSC200CFAN | B.080.4.5.C200 | 960 ÷ 1100 mm | 2000 mm | 4x |
| | | N° 6 | 80T/PSC250CFAN | B.080.4.5.C250 | 1110 ÷ 1350 mm | 2500 mm | 4x |
| | | N° 7 | 80T/PSC300CFAN | B.080.4.5.C300 | 1360 ÷ 1600 mm | 3000 mm | 4x |
| | — | — | 80T/PSC150SFAN | B.080.4.5.S150 | 700 ÷ 850 mm | 1500 mm | 4x |
| | | — | 80T/PSC165SFAN | B.080.4.5.S165 | 860 ÷ 950 mm | 1650 mm | 4x |
| | | — | 80T/PSC200SFAN | B.080.4.5.S200 | 960 ÷ 1100 mm | 2000 mm | 4x |
| | | — | 80T/PSC250SFAN | B.080.4.5.S250 | 1110 ÷ 1350 mm | 2500 mm | 4x |
| | | — | 80T/PSC300SFAN | B.080.4.5.S300 | 1360 ÷ 1600 mm | 3000 mm | 4x |



80 kg



N.2 Hydraulic stopper
N.2 Fermi idraulici



Suitable for naval sector
Adatto per settore navale



Turned wheels
Ruote tornite

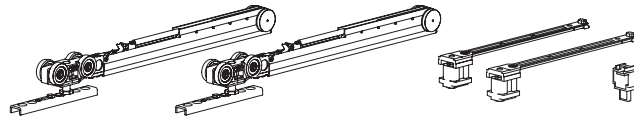

ART. 1280
(8000.01280)
(8010.01280)

FLUID



120 kg



N.2 Fluid dampers
N.2 Fermi ammortizzati
Fluid



Ball bearings
Cuscinetti a sfera

| | | | OLD CODE | NEW CODE | | TRACK-BINARIO | |
|----------------|---|------|----------|-----------------------|----------------|---------------|----|
| KIT | ● | N° 6 | — | K.120.2.5.C | Min. 810 mm | — | 4x |
| | | — | — | K.120.2.5.S | Min. 810 mm | — | 4x |
| BLISTER | ● | N° 4 | — | B.120.2.5.C150 | 810 ÷ 850 mm | 1500 mm | 4x |
| | | N° 5 | — | B.120.2.5.C165 | 860 ÷ 950 mm | 1650 mm | 4x |
| | | N° 5 | — | B.120.2.5.C200 | 960 ÷ 1100 mm | 2000 mm | 4x |
| | | N° 6 | — | B.120.2.5.C250 | 1110 ÷ 1350 mm | 2500 mm | 4x |
| | | N° 7 | — | B.120.2.5.C300 | 1360 ÷ 1600 mm | 3000 mm | 4x |
| | | — | — | B.120.2.5.S150 | 700 ÷ 850 mm | 1500 mm | 4x |
| | | — | — | B.120.2.5.S165 | 860 ÷ 950 mm | 1650 mm | 4x |
| | | — | — | B.120.2.5.S200 | 960 ÷ 1100 mm | 2000 mm | 4x |
| | | — | — | B.120.2.5.S250 | 1110 ÷ 1350 mm | 2500 mm | 4x |
| | | — | — | B.120.2.5.S300 | 1360 ÷ 1600 mm | 3000 mm | 4x |

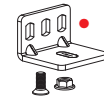
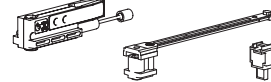
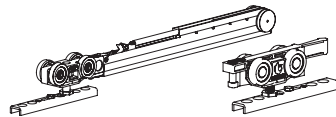

ART. 1280
(8000.01280)
(8010.01280)

FLUID



120 kg



N.1 Fluid damper
N.1 Fermo ammortizzato
Fluid



N.1 Shock absorber
N.1 Fermo a pinza
ammortizzato



Ball bearings
Cuscinetti a sfera

| | | | OLD CODE | NEW CODE | | TRACK-BINARIO | |
|----------------|---|------|----------|-----------------------|----------------|---------------|----|
| KIT | ● | N° 6 | — | K.120.1.5.C | Min. 600 mm | — | 4x |
| | | — | — | K.120.1.5.S | Min. 600 mm | — | 4x |
| BLISTER | ● | N° 4 | — | B.120.1.5.C150 | 700 ÷ 850 mm | 1500 mm | 4x |
| | | N° 5 | — | B.120.1.5.C165 | 860 ÷ 950 mm | 1650 mm | 4x |
| | | N° 5 | — | B.120.1.5.C200 | 960 ÷ 1100 mm | 2000 mm | 4x |
| | | N° 6 | — | B.120.1.5.C250 | 1110 ÷ 1350 mm | 2500 mm | 4x |
| | | N° 7 | — | B.120.1.5.C300 | 1360 ÷ 1600 mm | 3000 mm | 4x |
| | | — | — | B.120.1.5.S150 | 700 ÷ 850 mm | 1500 mm | 4x |
| | | — | — | B.120.1.5.S165 | 860 ÷ 950 mm | 1650 mm | 4x |
| | | — | — | B.120.1.5.S200 | 960 ÷ 1100 mm | 2000 mm | 4x |
| | | — | — | B.120.1.5.S250 | 1110 ÷ 1350 mm | 2500 mm | 4x |
| | | — | — | B.120.1.5.S300 | 1360 ÷ 1600 mm | 3000 mm | 4x |

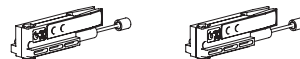
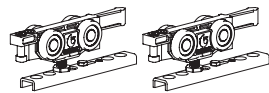

ART. 1280
(8000.01280)
(8010.01280)

FLUID



120 kg



N.2 Shock absorber
N.2 Fermi a pinza
ammortizzati



Ball bearings
Cuscinetti a sfera

| | | | OLD CODE | NEW CODE | | TRACK-BINARIO | |
|----------------|---|------|----------|-----------------------|----------------|---------------|----|
| KIT | ● | N° 6 | — | K.120.3.5.C | Min. 600 mm | — | 5x |
| | | — | — | K.120.3.5.S | Min. 600 mm | — | 5x |
| BLISTER | ● | N° 4 | — | B.120.3.5.C150 | 700 ÷ 850 mm | 1500 mm | 4x |
| | | N° 5 | — | B.120.3.5.C165 | 860 ÷ 950 mm | 1650 mm | 4x |
| | | N° 5 | — | B.120.3.5.C200 | 960 ÷ 1100 mm | 2000 mm | 4x |
| | | N° 6 | — | B.120.3.5.C250 | 1110 ÷ 1350 mm | 2500 mm | 4x |
| | | N° 7 | — | B.120.3.5.C300 | 1360 ÷ 1600 mm | 3000 mm | 4x |
| | | — | — | B.120.3.5.S150 | 700 ÷ 850 mm | 1500 mm | 4x |
| | | — | — | B.120.3.5.S165 | 860 ÷ 950 mm | 1650 mm | 4x |
| | | — | — | B.120.3.5.S200 | 960 ÷ 1100 mm | 2000 mm | 4x |
| | | — | — | B.120.3.5.S250 | 1110 ÷ 1350 mm | 2500 mm | 4x |
| | | — | — | B.120.3.5.S300 | 1360 ÷ 1600 mm | 3000 mm | 4x |

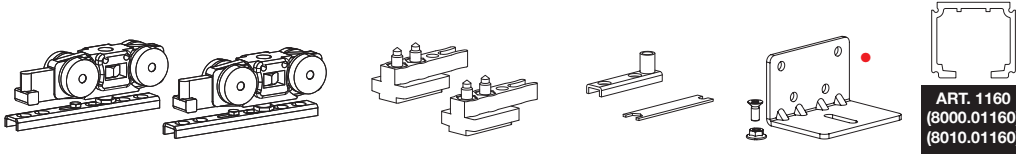

| | | | OLD CODE | NEW CODE | | TRACK-BINARIO | |
|----------------|---|------|-----------------|----------------|----------------|-------------------|----|
| KIT | ● | N° 6 | 160/T/G/SC/CON | K.160.0.5.C | Min. 700 mm | — | 5x |
| | | — | 160/T/G/SC/SEN | K.160.0.5.S | Min. 700 mm | — | 5x |
| BLISTER | ● | N° 6 | 160/T/P/SC200CO | B.160.0.5.C200 | 960 ÷ 1100 mm | 2000 mm | 4x |
| | | N° 7 | 160/T/P/SC250CO | B.160.0.5.C250 | 1110 ÷ 1350 mm | 2500 mm | 4x |
| | | N° 8 | 160/T/P/SC300CO | B.160.0.5.C300 | 1360 ÷ 1600 mm | 3000 mm | 4x |
| | | — | 160/T/P/SC200SE | B.160.0.5.S200 | 960 ÷ 1100 mm | 2000 mm | 4x |
| | | — | 160/T/P/SC250SE | B.160.0.5.S250 | 1110 ÷ 1350 mm | 2500 mm | 4x |
| | | — | 160/T/P/SC300SE | B.160.0.5.S300 | 1360 ÷ 1600 mm | 3000 mm | 4x |



160 kg



N.2 Standard stoppers
N.2 Fermi standard



Turned wheels
Ruote tornite

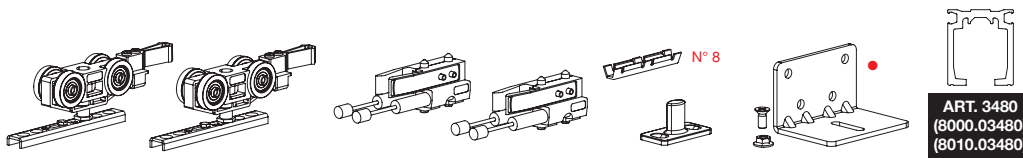

| | | | OLD CODE | NEW CODE | | TRACK-BINARIO | |
|----------------|---|------|----------|----------------|----------------|-------------------|----|
| KIT | ● | N° 6 | — | K.180.3.5.C | Min. 700 mm | — | 5x |
| | | — | — | K.180.3.5.S | Min. 700 mm | — | 5x |
| BLISTER | ● | N° 6 | — | B.180.3.5.C200 | 960 ÷ 1100 mm | 2000 mm | 4x |
| | | N° 7 | — | B.180.3.5.C250 | 1110 ÷ 1350 mm | 2500 mm | 4x |
| | | N° 8 | — | B.180.3.5.C300 | 1360 ÷ 1600 mm | 3000 mm | 4x |
| | | — | — | B.180.3.5.S200 | 960 ÷ 1100 mm | 2000 mm | 4x |
| | | — | — | B.180.3.5.S250 | 1110 ÷ 1350 mm | 2500 mm | 4x |
| | | — | — | B.180.3.5.S300 | 1360 ÷ 1600 mm | 3000 mm | 4x |



180 kg



N.2 Shock absorber
N.2 Fermi a pinza
ammortizzati



Ball bearings
Cuscinetti a sfera

Hide

Slides with hidden bracket
Scorrevoli con staffa a scomparsa

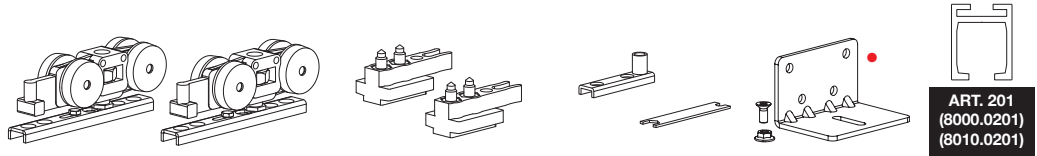





ART. 201
(8000.0201)
(8010.0201)

 **240 kg**

 N.2 Standard stoppers
N.2 Fermi standard

 Turned wheels
Ruote tornite

| |  |  | OLD CODE | NEW CODE |  | TRACK-BINARIO  |  |
|----------------|---|---|-----------------|----------------|---|--|---|
| KIT | ● | N° 7 | 240/T/G/SC/CON | K.240.0.5.C | Min. 700 mm | — | 5x |
| | | — | 240/T/G/SC/SEN | K.240.0.5.S | Min. 700 mm | — | 5x |
| BLISTER | ● | N° 6 | 240/T/P/SC200CO | B.240.0.5.C200 | 960 ÷ 1100 mm | 2000 mm | 4x |
| | | N° 7 | 240/T/P/SC250CO | B.240.0.5.C250 | 1110 ÷ 1350 mm | 2500 mm | 4x |
| | | N° 8 | 240/T/P/SC300CO | B.240.0.5.C300 | 1360 ÷ 1600 mm | 3000 mm | 4x |
| | | — | 240/T/P/SC200SE | B.240.0.5.S200 | 960 ÷ 1100 mm | 2000 mm | 4x |
| | | — | 240/T/P/SC250SE | B.240.0.5.S250 | 1110 ÷ 1350 mm | 2500 mm | 4x |
| | | — | 240/T/P/SC300SE | B.240.0.5.S300 | 1360 ÷ 1600 mm | 3000 mm | 4x |

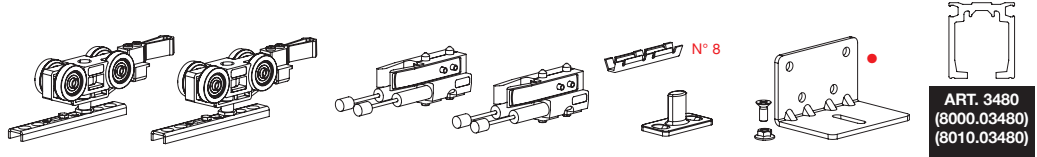







ART. 3480
(8000.03480)
(8010.03480)

FLUID

 **250 kg**

 N.2 Shock absorber
N.2 Fermi a pinza
ammortizzati

 Ball bearings
Cuscinetti a sfera

| |  |  | OLD CODE | NEW CODE |  | TRACK-BINARIO  |  |
|----------------|---|---|----------|----------------|---|--|---|
| KIT | ● | N° 7 | — | K.250.3.5.C | Min. 700 mm | — | 5x |
| | | — | — | K.250.3.5.S | Min. 700 mm | — | 5x |
| BLISTER | ● | N° 6 | — | B.250.3.5.C200 | 960 ÷ 1100 mm | 2000 mm | 4x |
| | | N° 7 | — | B.250.3.5.C250 | 1110 ÷ 1350 mm | 2500 mm | 4x |
| | | N° 8 | — | B.250.3.5.C300 | 1360 ÷ 1600 mm | 3000 mm | 4x |
| | | — | — | B.250.3.5.S200 | 960 ÷ 1100 mm | 2000 mm | 4x |
| | | — | — | B.250.3.5.S250 | 1110 ÷ 1350 mm | 2500 mm | 4x |
| | | — | — | B.250.3.5.S300 | 1360 ÷ 1600 mm | 3000 mm | 4x |

N.2 Soft damper stoppers
N.2 Fermi ammortizzati

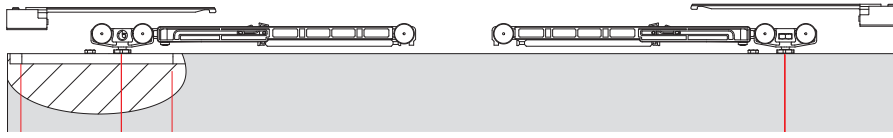

N.1 Soft damper stopper + N.1 Standard stopper
N.1 Fermo ammortizzato + N.1 Fermo standard

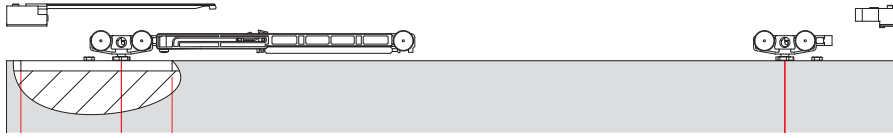

N.2 Standard stoppers
N.2 Fermi standard

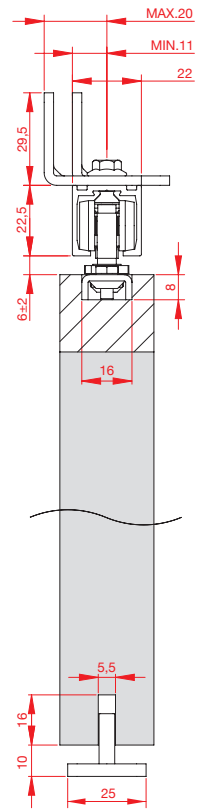
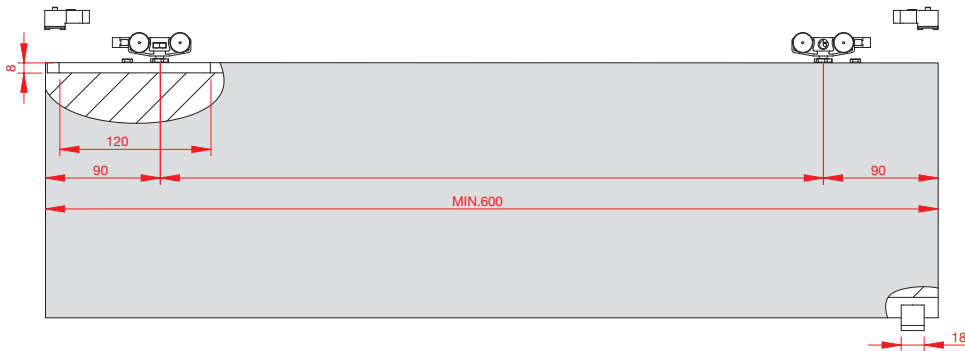

N.2 Fluid dampers
N.2 Fermi ammortizzati Fluid

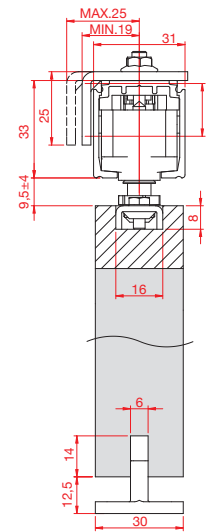
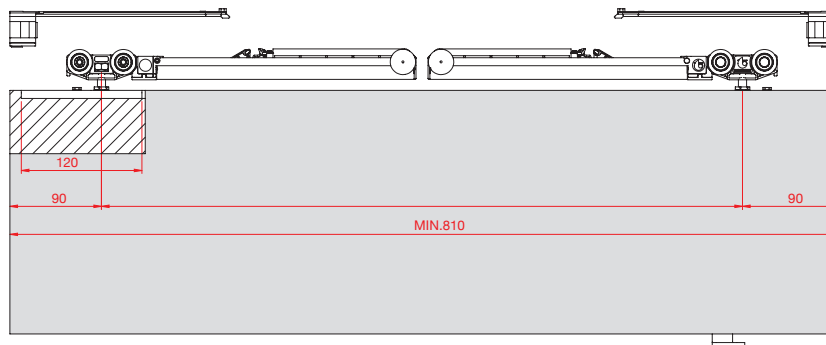

N.1 Fluid damper + N.1 Shock absorber
N.1 Fermo ammortizzato Fluid + N.1 Fermo a pinza ammortizzato

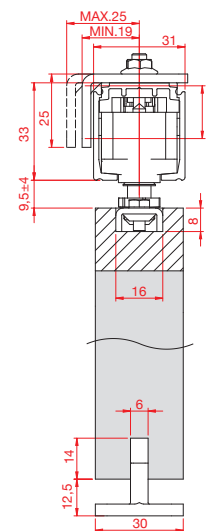
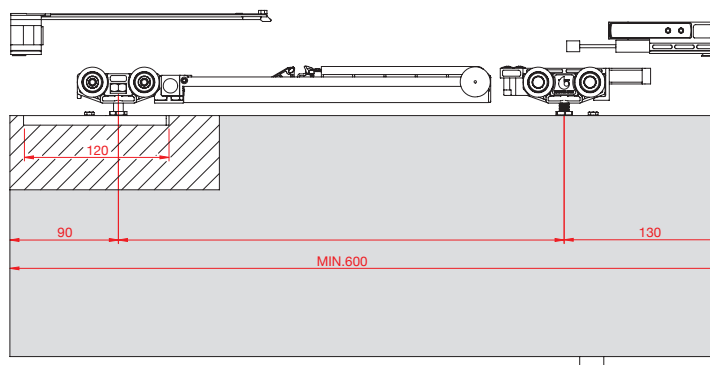

N.2 Shock absorber
N.2 Fermi a pinza ammortizzati

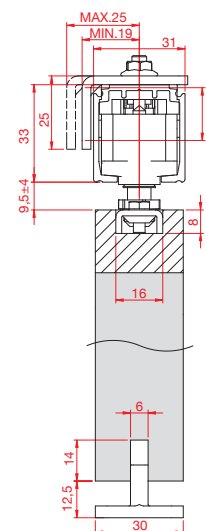
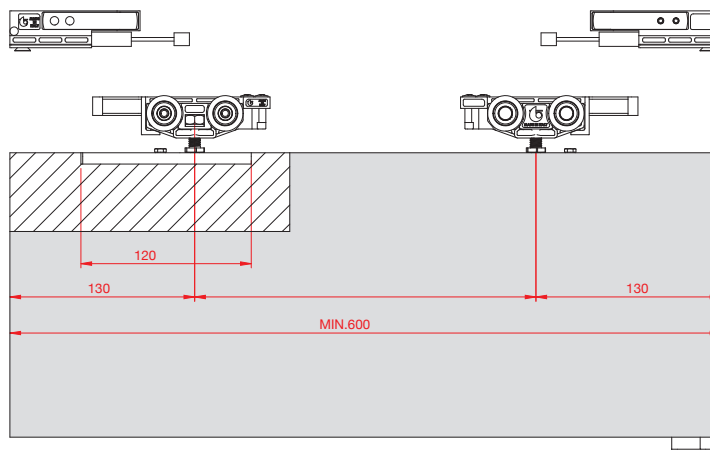

FLUID



50 kg
80 kg
120 kg

N.2 Standard stoppers
N.2 Fermi standard

80 kg

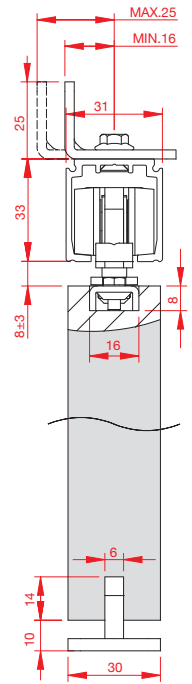
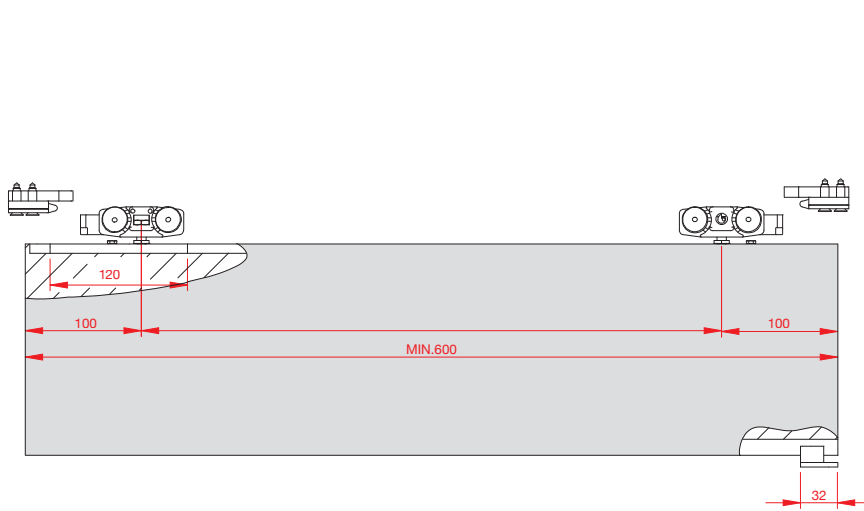

N.2 Hydraulic stopper
N.2 Fermi idraulici

80 kg

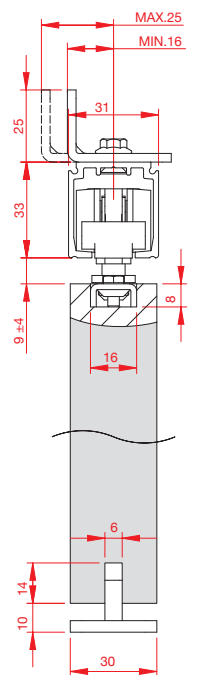
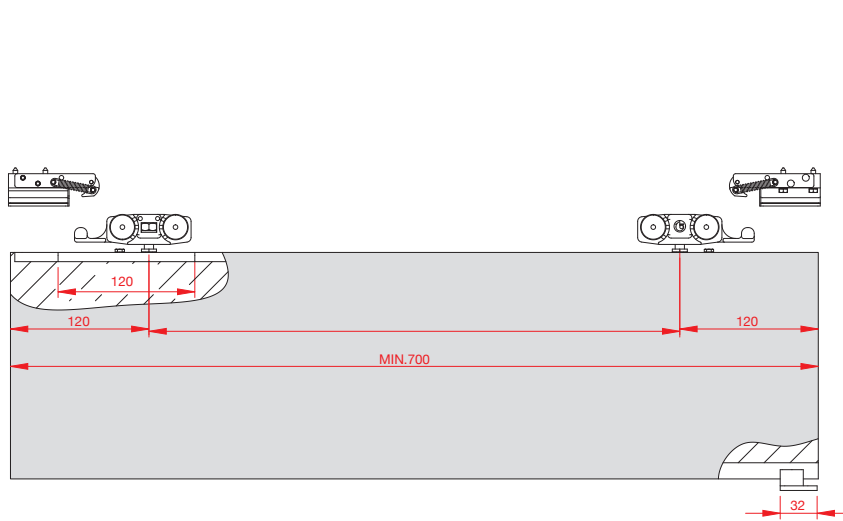

N.2 Standard stoppers
N.2 Fermi standard

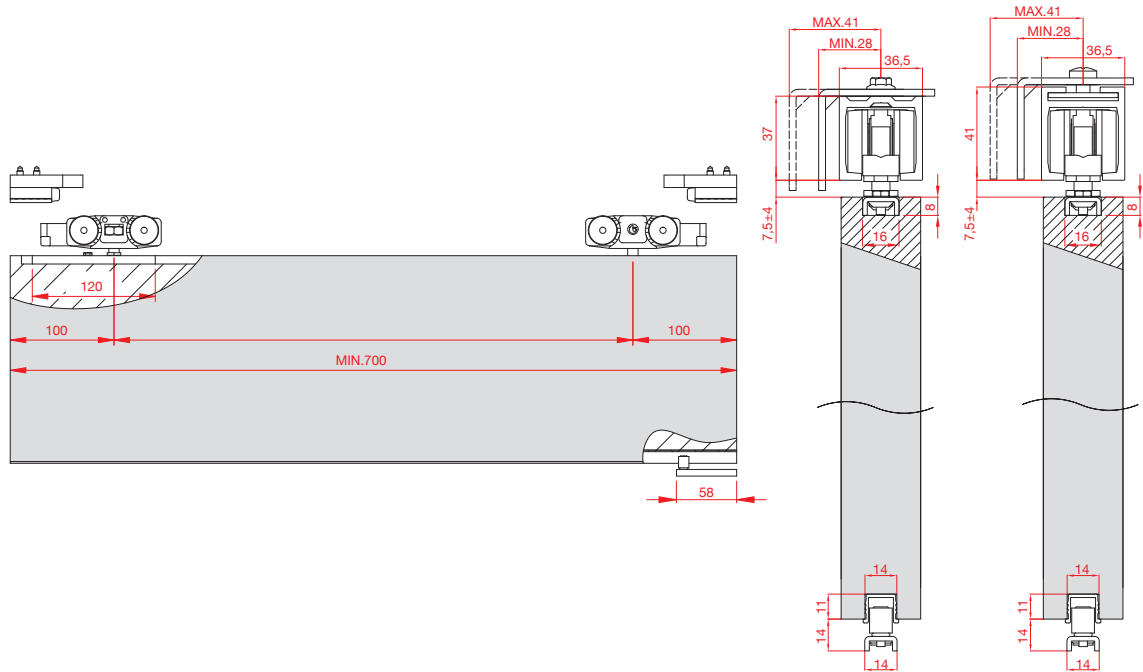

160 kg



N.2 Shock absorber
N.2 Fermi a pinza ammortizzati

FLUID

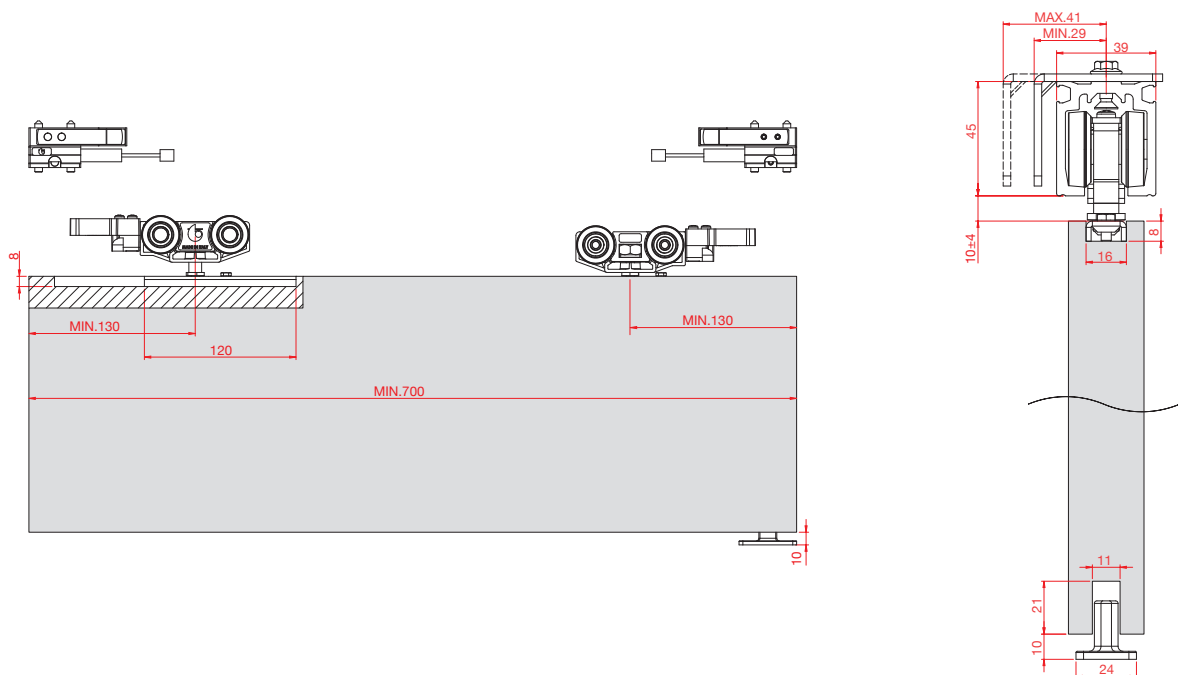
180 kg



N.2 Standard stoppers
N.2 Fermi standard

240 kg

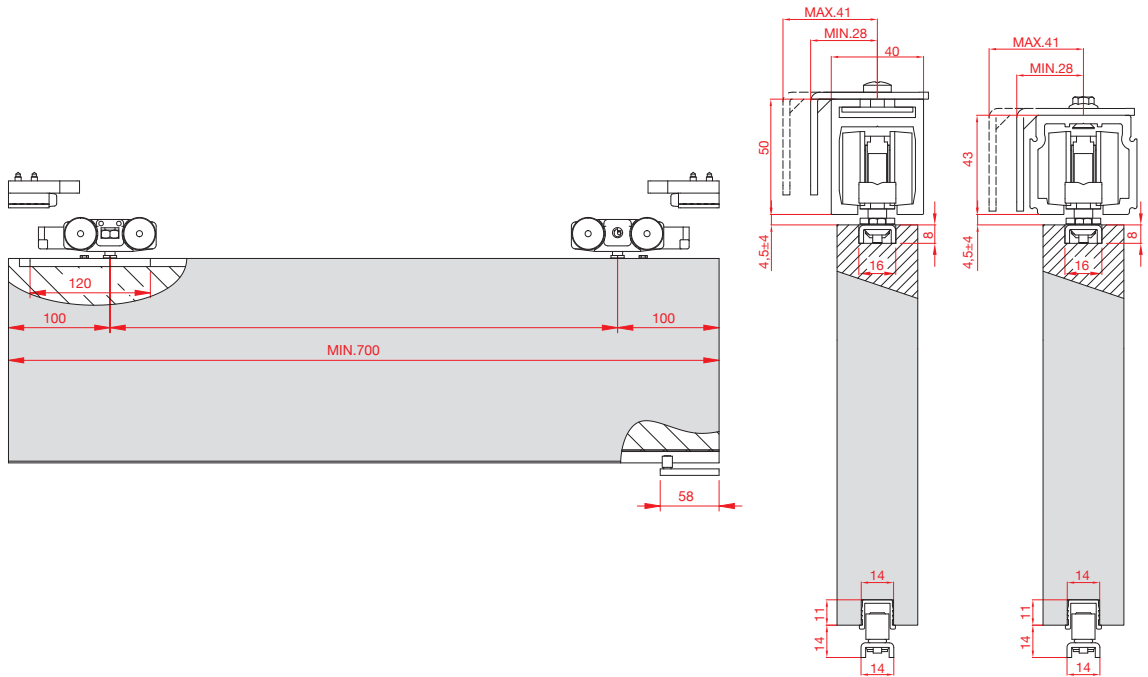

N.2 Shock absorber
N.2 Fermi a pinza ammortizzati

250 kg

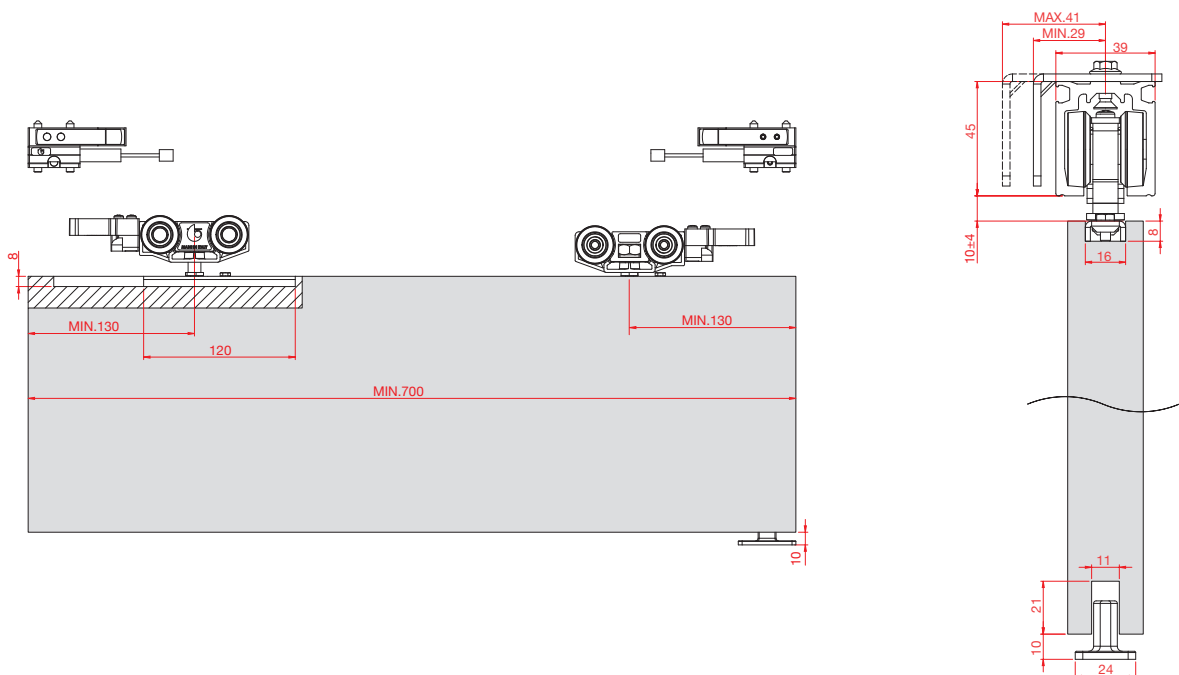

FLUID



Lower guides

Guide inferiori

For glass doors
Per porte in vetro



Lower guides / Guide inferiori

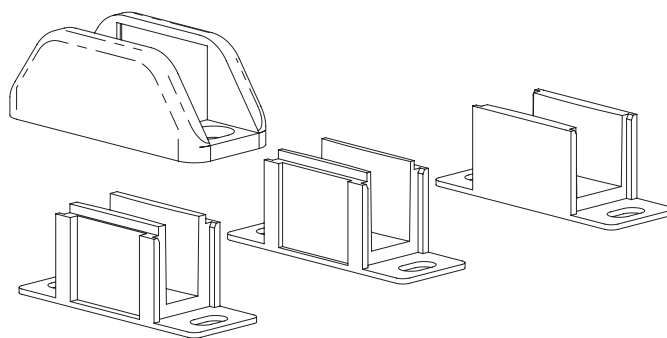
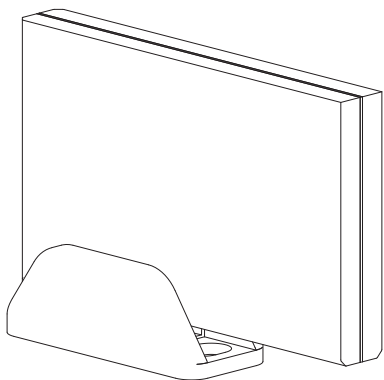

ART. 1486/8/10/12

LOWER GUIDE / GUIDE INFERIORI

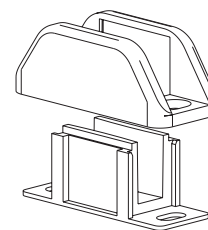
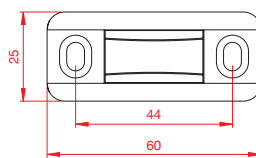
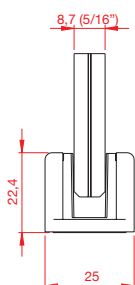
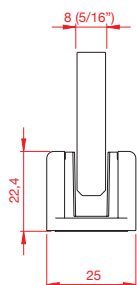
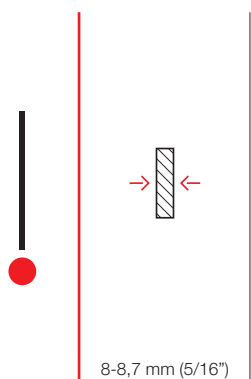

ART. 1486/8

LOWER GUIDE / GUIDE INFERIORI

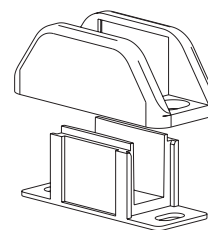
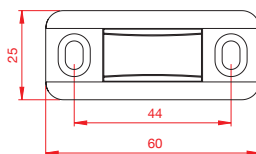
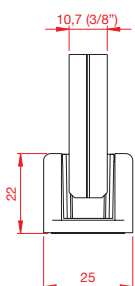
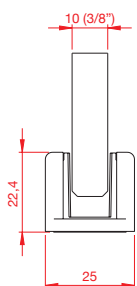
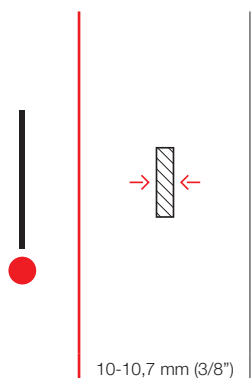

ART. 1486/10

LOWER GUIDE / GUIDE INFERIORI

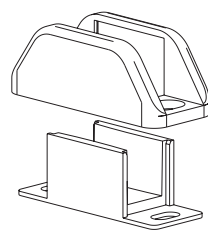
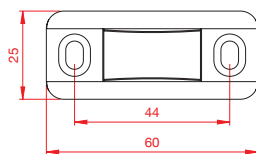
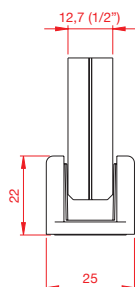
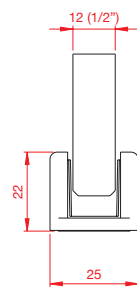
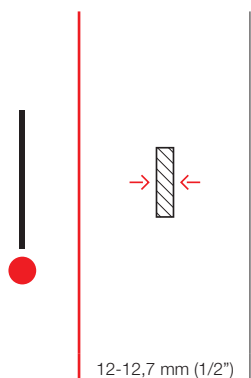

ART. 1486/12

Adjustable lower guides / Guide inferiori regolabili

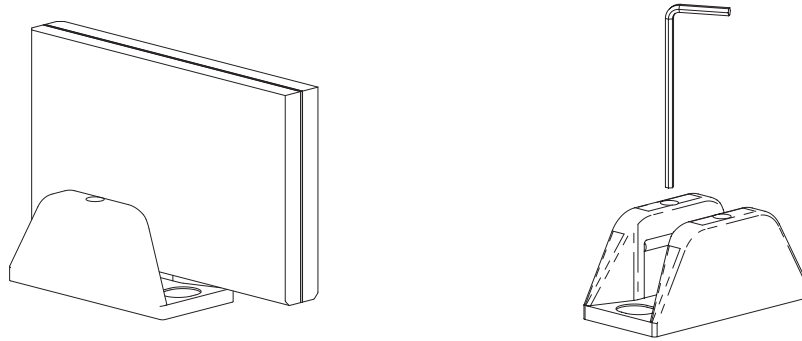

ART. 1488

LOWER GUIDE / GUIDE INFERIORI

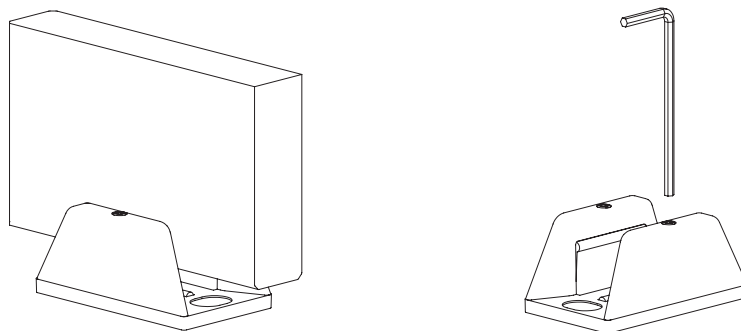
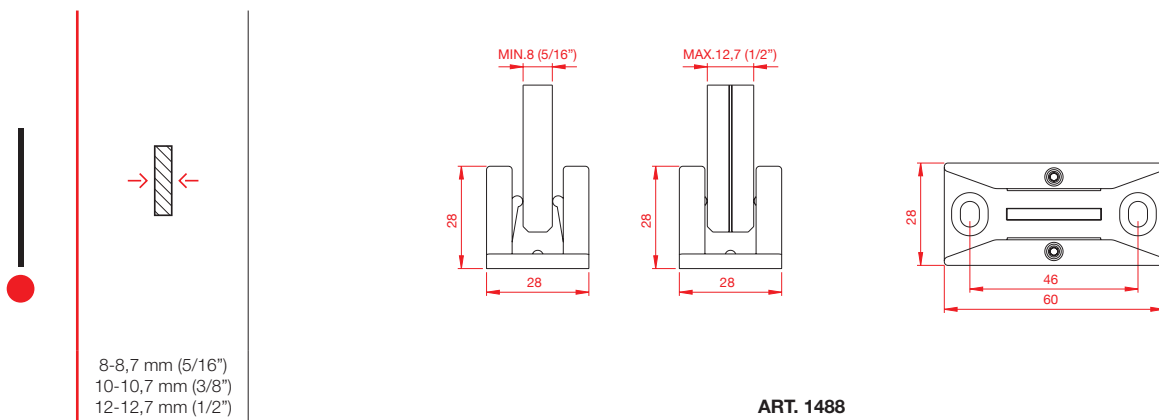

ART. 1498

LOWER GUIDE / GUIDE INFERIORI

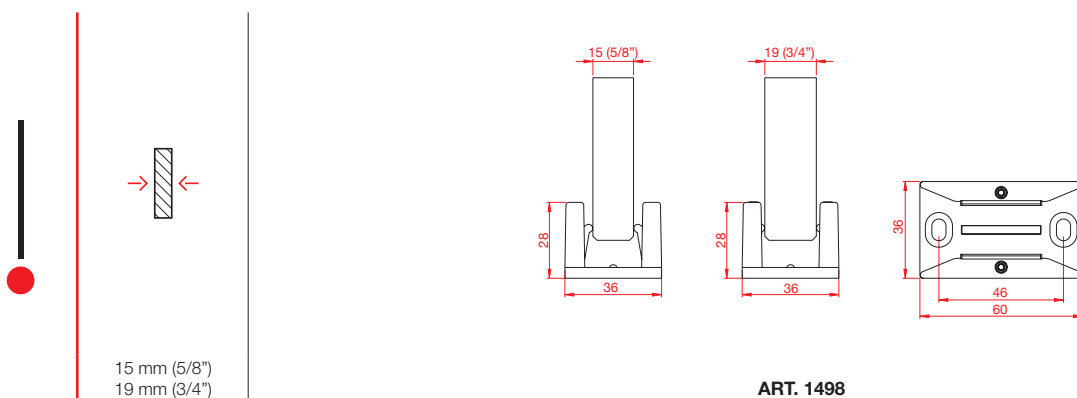

Lower guides / Guide inferiori

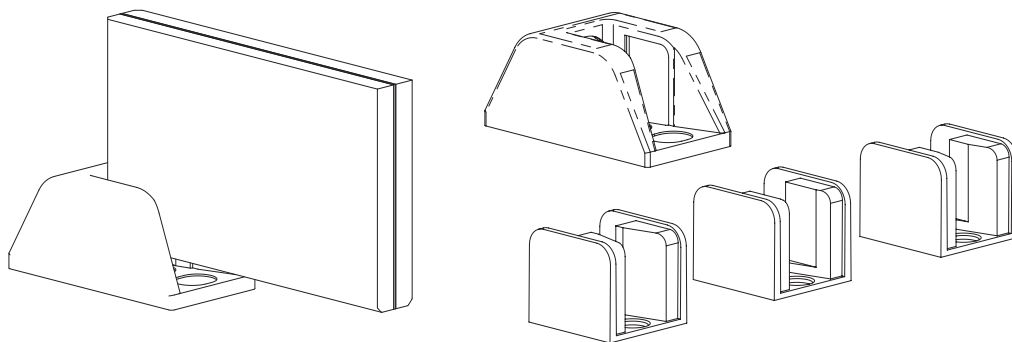

ART. 1489/8/10/12

LOWER GUIDE / GUIDE INFERIORI

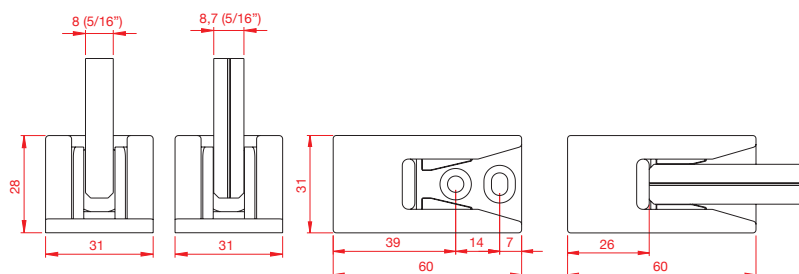
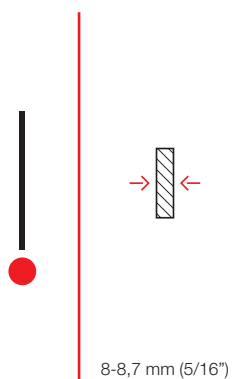

ART. 1489/8

LOWER GUIDE / GUIDE INFERIORI

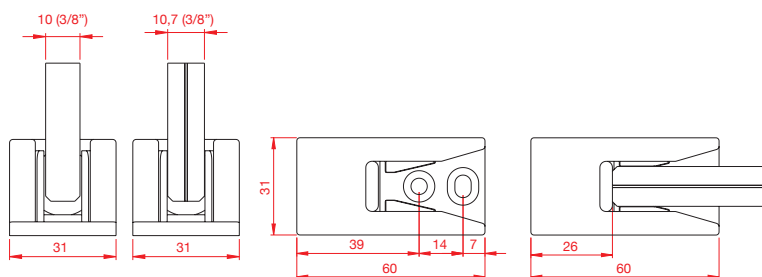
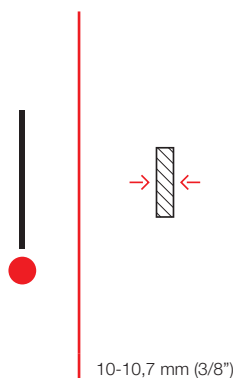

ART. 1489/10

LOWER GUIDE / GUIDE INFERIORI

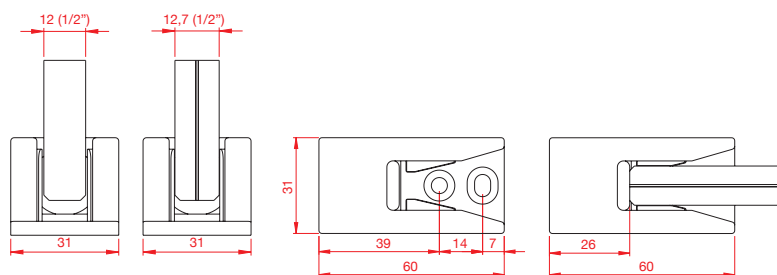
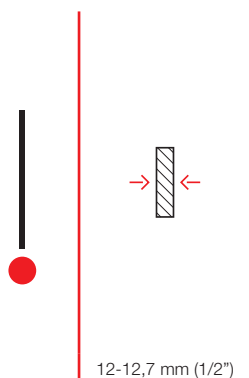

ART. 1489/12



Magic²

The original invisible sliding doors system
Il sistema invisibile originale per porte scorrevoli

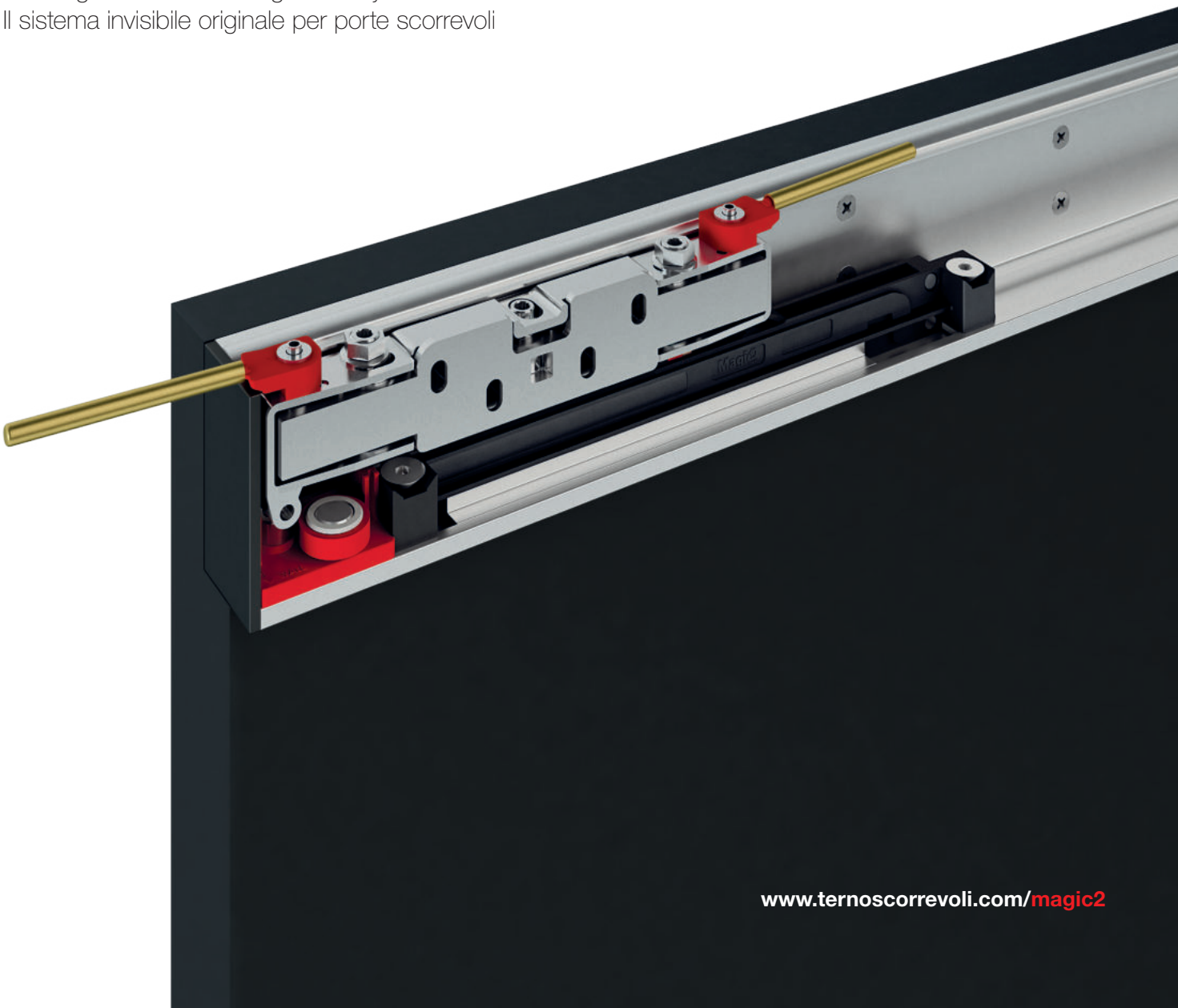

Tracks / Binari

ALUMINUM FINISHES CODES / CODICI FINITURE ALLUMINIO



8 ... 0.0

| | | |
|---|---|---|
| 01 • (Anodized Silver / Argento - A) | 13 • (Brushed Anodized Dark Brown / E3 Spazzolato - E3S) | 17 • (Brushed Anodized Nickel / Nichel Spazzolato - NKS) |
| 02 • (Brushed Anodized Silver / Argento Spazzolato - AS) | 14 • (Anodized Black / Nero - N) | 25 • (Brushed Anodized Graphite / Grafite Spazzolato - GRFS) |
| 12 • (Anodized Dark Brown / E3 - E3) | 15 • (Brushed Anodized Black / Nero Spazzolato - NS) | 26 • (Anodized Graphite / Grafite - GRF) |

01 - 02 STANDARD / 12 - 13 - 14 - 15 - 17 - 25 - 26 SPECIAL

Magic2

COMPLETE BOX KIT / KIT COMPLETO IN SCATOLA



K Complete kit / Kit completo

| | | |
|------|-------------------------------------|---------------------------------|
| 0031 | | Magic2 - Wood Magic2 - Legno |
| 1 | | 1100 mm |
| 2 | | 1800 mm |
| 01 | Standard Finish / Finitura Standard | |

Magic2 Frame

COMPLETE BOX KIT / KIT COMPLETO IN SCATOLA



K Complete kit / Kit completo

| | | |
|------|--|-----------------------|
| 0461 | | 1500 mm - 80kg |
| 0462 | | 1100 mm - 80kg |
| 1 | N.2 Soft damper stoppers N.2 Fermi ammortizzati | |
| 1 | | 2200 mm |
| 2 | | 2600 mm |
| 3 | | 3000 mm |
| 02 | Brushed Anodized Silver / Argento Spazzolato | |
| 13 | Brushed Anodized Dark Brown / E3 Spazzolato | |
| 15 | Brushed Anodized Black / Nero Spazzolato | |
| 17 | Brushed Anodized Nickel / Nichel Spazzolato | |
| 25 | Brushed Anodized Graphite / Grafite Spazzolato | |

Magic2 Vetro

COMPLETE BOX KIT / KIT COMPLETO IN SCATOLA



K Complete kit / Kit completo

| | | |
|------|--|-----------------------|
| 0041 | | 1100 mm - 80kg |
| 0042 | | 1800 mm - 80kg |
| 1 | Glass thk. / Vetri sp. 8 mm (5/16") | |
| 2 | Glass thk. / Vetri sp. 10 mm (3/8") | |
| 3 | Glass thk. / Vetri sp. 12 mm (1/2") | |
| 02 | Brushed Anodized Silver / Argento Spazzolato | |

Magic2 Mix

COMPLETE BOX KIT / KIT COMPLETO IN SCATOLA



| | | |
|----------|-----------------------------|--|
| K | Complete kit / Kit completo | |
| | . | |
| | 0441 | Magic2 MIX UP |
| | 0442 | Magic2 MIX DOWN |
| | 0443 | Magic2 MIX UP |
| | 0444 | Magic2 MIX DOWN |
| | . | |
| | 1 | 1100 mm → 38-40 mm |
| | 2 | 1800 mm → 38-40 mm |
| | 3 | 1100 mm → 42-44 mm |
| | 4 | 1800 mm → 42-44 mm |
| | . | |
| | 02 | Brushed Anodized Silver / Argento Spazzolato |
| | 15 | Brushed Anodized Black / Nero Spazzolato |

Magic2 Uni

COMPLETE BOX KIT / KIT COMPLETO IN SCATOLA



| | | |
|----------|-----------------------------|--|
| K | Complete kit / Kit completo | |
| | . | |
| | 0451 | 40 mm - 30 kg |
| | 0452 | 44 mm - 30 kg |
| | 0453 | 40 mm - 80 kg |
| | 0454 | 44 mm - 80 kg |
| | . | |
| | 1 | 1100 mm |
| | 2 | 1800 mm |
| | . | |
| | 02 | Brushed Anodized Silver / Argento Spazzolato |
| | 15 | Brushed Anodized Black / Nero Spazzolato |

EXAMPLE / ESEMPIO

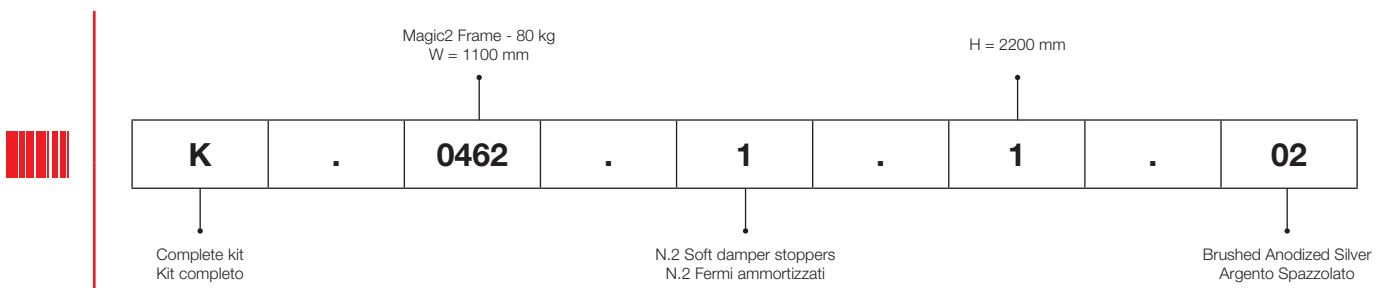

Magic2

PATENTED

Magic2 is the new **PATENTED** and **INVISIBLE** sliding door system outside the wall with soft-closing.

Magic2 è l'innovativo **SISTEMA INVISIBILE BREVETTATO** per porte scorrevoli esterno muro con fermi ammortizzati.





More than 50mm of damping motion

Magic2 system integrates new **PATENTED** dampers with 50 mm of braking motion, 20 mm longer than previous version of **Magic**, while keeping the same door dimensions.

Oltre 50 mm di frenatura

Il sistema **Magic2** integra nuovi fermi ammortizzati **BREVETTATI**, per una frenatura di oltre 50 mm, più di 20 mm rispetto al fermo del modello **Magic**, mantenendo gli stessi ingombri della porta.

PATENTED

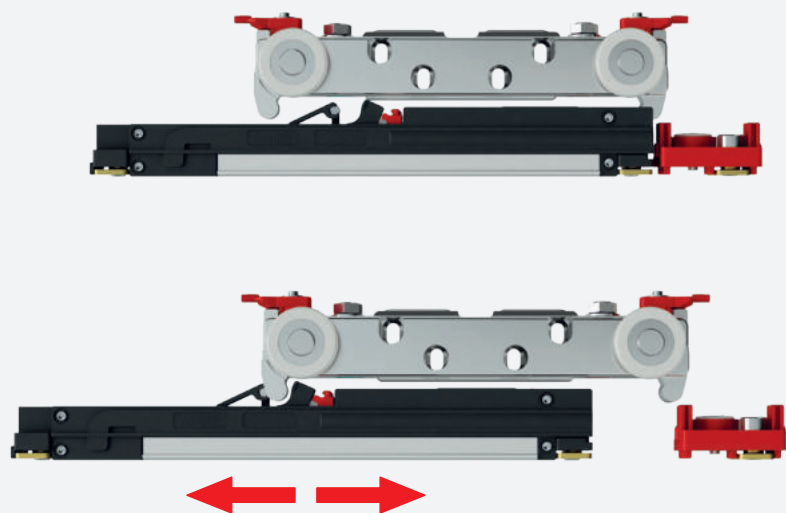
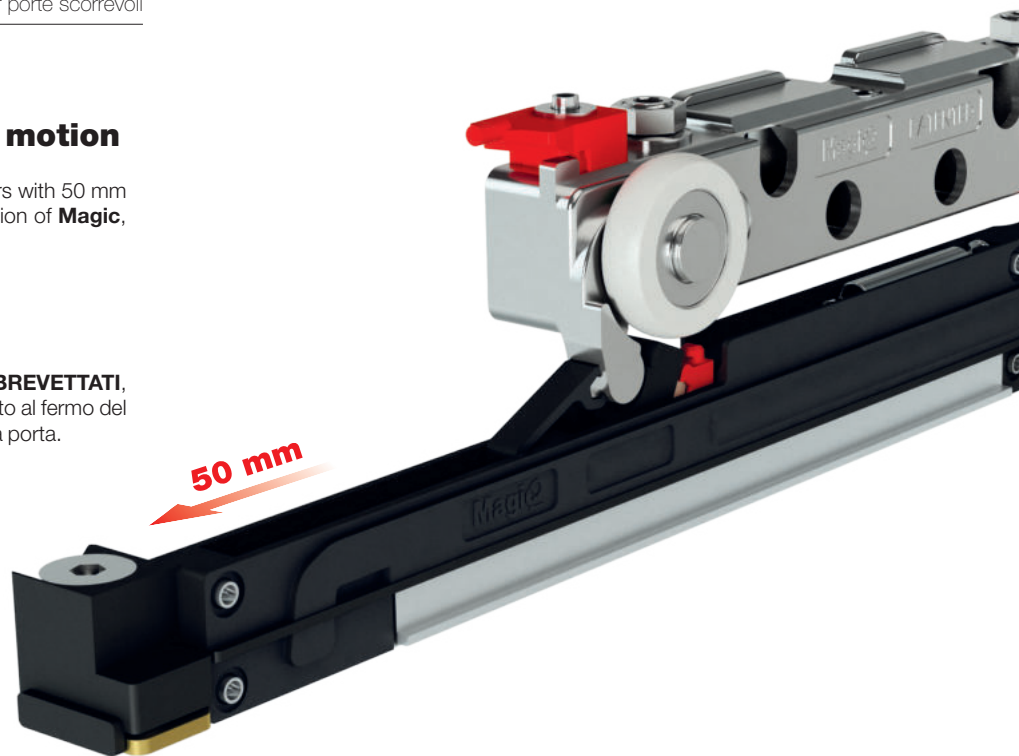

New dampers with adjustable positioning

New **Magic2** adjustable dampers were designed to be independent from wall-spacer wheels. New dampers are suitable to be moved into the track to allow door positioning adjustment.

Nuovi fermi con posizione regolabile

I nuovi fermi del **Magic2** sono stati progettati per essere indipendenti dal distanziale. All'occorrenza si possono spostare per regolare la posizione della porta.

New position of wall-spacer wheels

In **Magic2** system wall-spacer wheels are positioned on the door extremities. The wall-spacer wheels are so positioned in order to protect the door from wall contact, when wall surface are not plane.

Nuova posizione per le ruote distanziali

Nel sistema **Magic2** le ruote distanziali sono posizionate alle estremità della porta. Le ruote distanziali così posizionate proteggono la porta da contatti con la parete, in caso di muri con superfici irregolari.



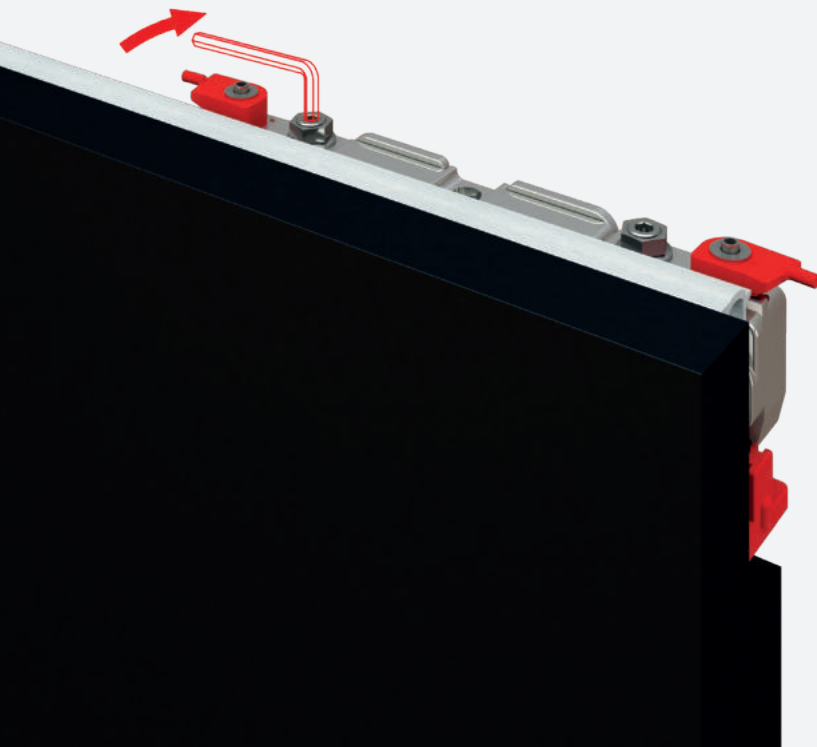

New patented adjustment system

New **Magic² PATENTED** sliding trolley integrates following door adjustments:

- Door height adjustment from floor
- Micrometric adjustment of door from wall
- Micrometric adjustment of door parallelism from wall

Door adjustments of wall distance and parallelism, are meant to compensate possible irregularities of wall. All adjustments are available in the top of sliding trolley, without removing the door.

Nuovo sistema brevettato di regolazione

Il nuovo scorrevole **Magic² BREVETTATO** integra le seguenti regolazioni:

- Regolazione dell'altezza della porta dal pavimento
- Regolazione micrometrica della distanza della porta dalla parete
- Regolazione micrometrica del parallelismo della porta rispetto alla parete

Le regolazioni di distanza e parallelismo della porta, si utilizzano per compensare eventuali irregolarità della parete. Tutte le regolazioni si realizzano dalla parte superiore dello scorrevole, senza sganciare la porta.

Practical anti-jumping system

Magic² sliding trolley includes two new turning anti-jumping activation elements. Turning anti-jumping activation elements are equipped with two safety levers, easy to rotate with no tools required. Safety levers, clearly visible, will have to be removed once anti-jumping system is activated in order to insert end caps.

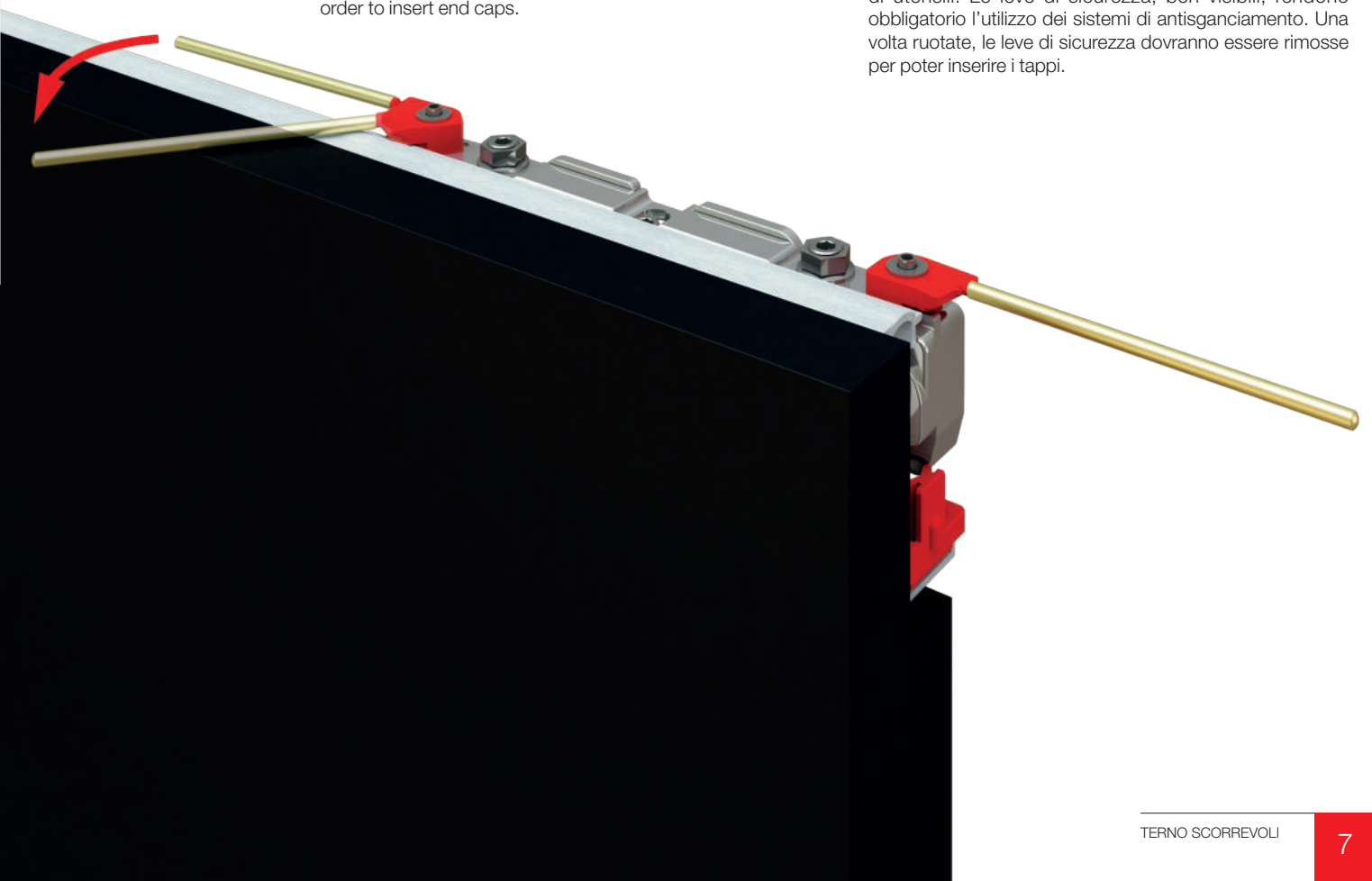

Pratico sistema di antisganciamento

Lo scorrevole **Magic²** comprende due nuovi elementi rotanti di antisganciamento. In questi nuovi elementi sono inserite due leve di sicurezza, per ruotarli senza l'utilizzo di utensili. Le leve di sicurezza, ben visibili, rendono obbligatorio l'utilizzo dei sistemi di antisganciamento. Una volta ruotate, le leve di sicurezza dovranno essere rimosse per poter inserire i tappi.



Silent lower guide

With the purpose of furtherly increase sliding quality, **Magic2** system combines a reinforced lower guide in Zamak (reliable and versatile), which slides in a silent plastic profile.

Guida inferiore silenziosa

Per migliorare ancor di più lo scorrimento, il sistema **Magic2** integra una guida inferiore rinforzata in zama (resistente e versatile), che scorre in un profilo in plastica molto silenzioso.

New patented bottom wheels designed for a better sliding

New **Magic2** bottom wheels are equipped with a **PATENTED** suspension spring system and were designed with a larger diameter, bigger bearing and steel pivots. Rubber surface have been enlarged as well, in order to reinforce wheels and improve sliding quality.

An additional important **PATENTED** innovation in lower sliding system is the introduction of two padded fixed springs which can grant damping function during door motion up to 40kg. Over 40kg of door weight and up to 80kg of maximum load capacity, new bottom wheels will be more flexible than previous version, with their Zamak surface to lean on a rubber internal cylinder, which act as a small shock absorber, granting more stability during sliding motion.

The **Magic2** wheels rubber have high performance:

- it does not leave any trace or sign on sliding surface like floors and walls
- it does not deform over time

Ruote inferiori brevettate per una migliore scorrevolezza

Le nuove ruote inferiori del sistema **Magic2** hanno molleggio **BREVETTATO**, e sono state progettate con diametro, cuscinetti e perni in acciaio maggiorati. Anche il rivestimento in gomma è stato raddoppiato per aumentare la forza e la scorrevolezza delle ruote.

Un'altra importante innovazione **BREVETTATA** nel sistema di scorrimento inferiore è l'inserimento di due molle fisse maggiorate che permettono di ammortizzare il movimento della porta fino ad una portata di 40 kg. Oltre i 40 kg, e fino ad un massimo di 80 kg, queste nuove ruote flettono maggiormente e la superficie realizzata in zama si appoggia su di un cilindro di gomma interno che funge da ammortizzatore supplementare garantendo maggior stabilità.

La gomma delle ruote di **Magic2** è altamente performante:

- non lascia traccia sulle superfici di scorrimento come pavimenti e pareti
- non si deforma nel tempo

KG 0 < KG 40

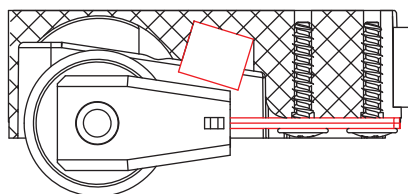

KG 40 < KG 80

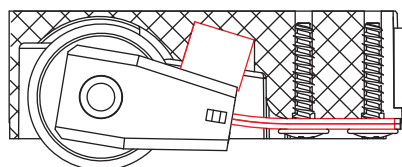

Built-in sliding track with not-through milling

Upper sliding track can be installed "built-in" into a blind milling. Laterally, track's end caps won't be visible, improving even more the aesthetics of door. Door installation and adjustment are not going to be different than usual, because available on the top of the door.

Binario incassato in fresata non passante

Il binario superiore può essere incassato in una fresata cieca. Lateralmente non saranno visibili i tappi del binario, migliorando ulteriormente l'estetica della porta. L'installazione e regolazione della porta non variano perché le regolazioni si effettuano dal lato superiore della porta.

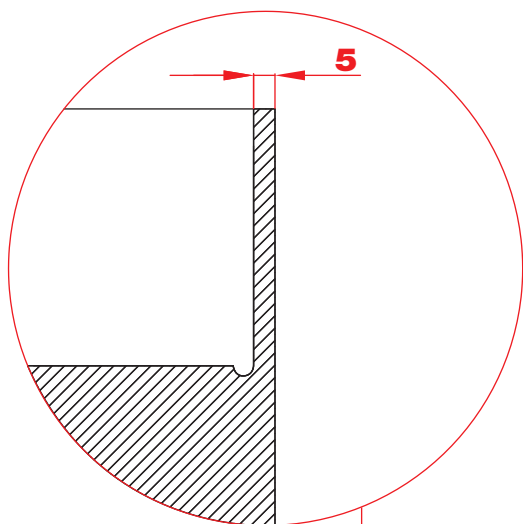

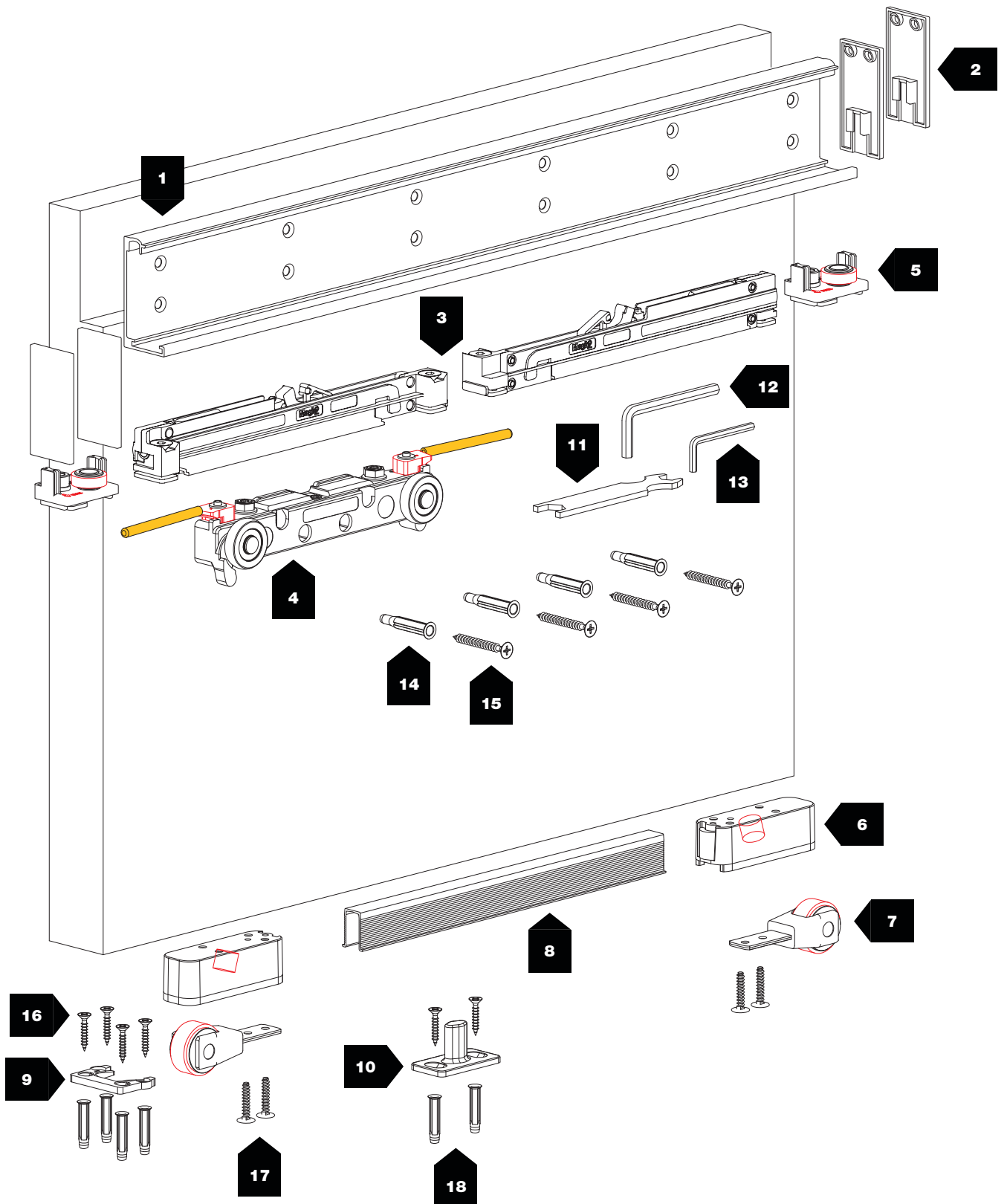











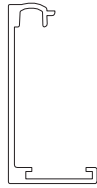
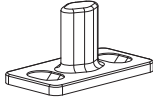
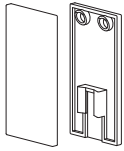

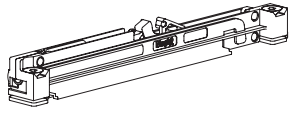

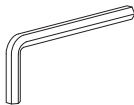
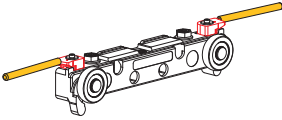

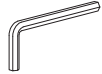
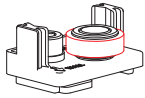
680 ÷ 1800 mm

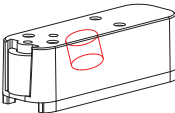

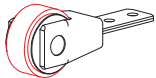
80 kg

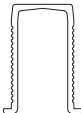

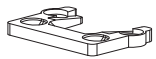
10 mm

| N° | | | kg | | N° | | | kg | |
|----|---------|---|----|---|----|-------------|---|----|--|
| 1 | 2850 |  | — | | 10 | 2855 |  | — | |
| 2 | 2851/N |  | — | | 11 | 1025 |  | — | |
| | 2851/A | | | | | | | | |
| 3 | 2864-80 |  | 80 |  | 12 | 538 |  | — | |
| 4 | 2852 |  | 80 |  | 13 | 654 |  | — | |
| 5 | 2856 |  | — |  | 14 | FISCHER UX6 |  | — | |
| 6 | 2858 |  | 80 |  | 15 | 4,5x40 |  | — | |
| 7 | 2857 |  | 80 |  | 16 | 4x30 |  | — | |
| 8 | 121 |  | — | | 17 | 4x20 |  | — | |
| 9 | 2859 |  | — | | 18 | FISCHER SX5 |  | — | |



80 kg



N.2 Soft damper stoppers
N.2 Fermi ammortizzati



Customizable door width
Larghezza porta personalizzabile



Patented system
Sistema brevettato



Standard Finish
Finitura Standard

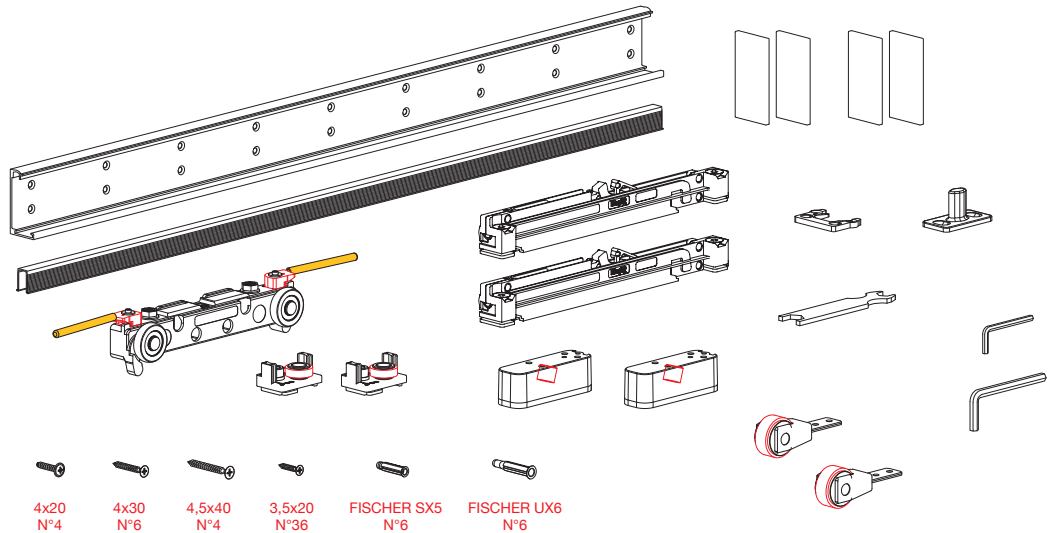

4x20 N°4 4x30 N°6 4,5x40 N°4 3,5x20 N°36 FISCHER SX5 N°6 FISCHER UX6 N°6

| OLD CODE | NEW CODE | MIN | |
|-------------|-------------|---------|------|
| MAGIC2/1100 | K.0031.1.01 | 1100 mm | 6x * |
| MAGIC2/1800 | K.0031.2.01 | 1800 mm | 4x |

* For export - Min. 12x

MEASUREMENTS DESCRIPTION / DESCRIZIONE MISURE

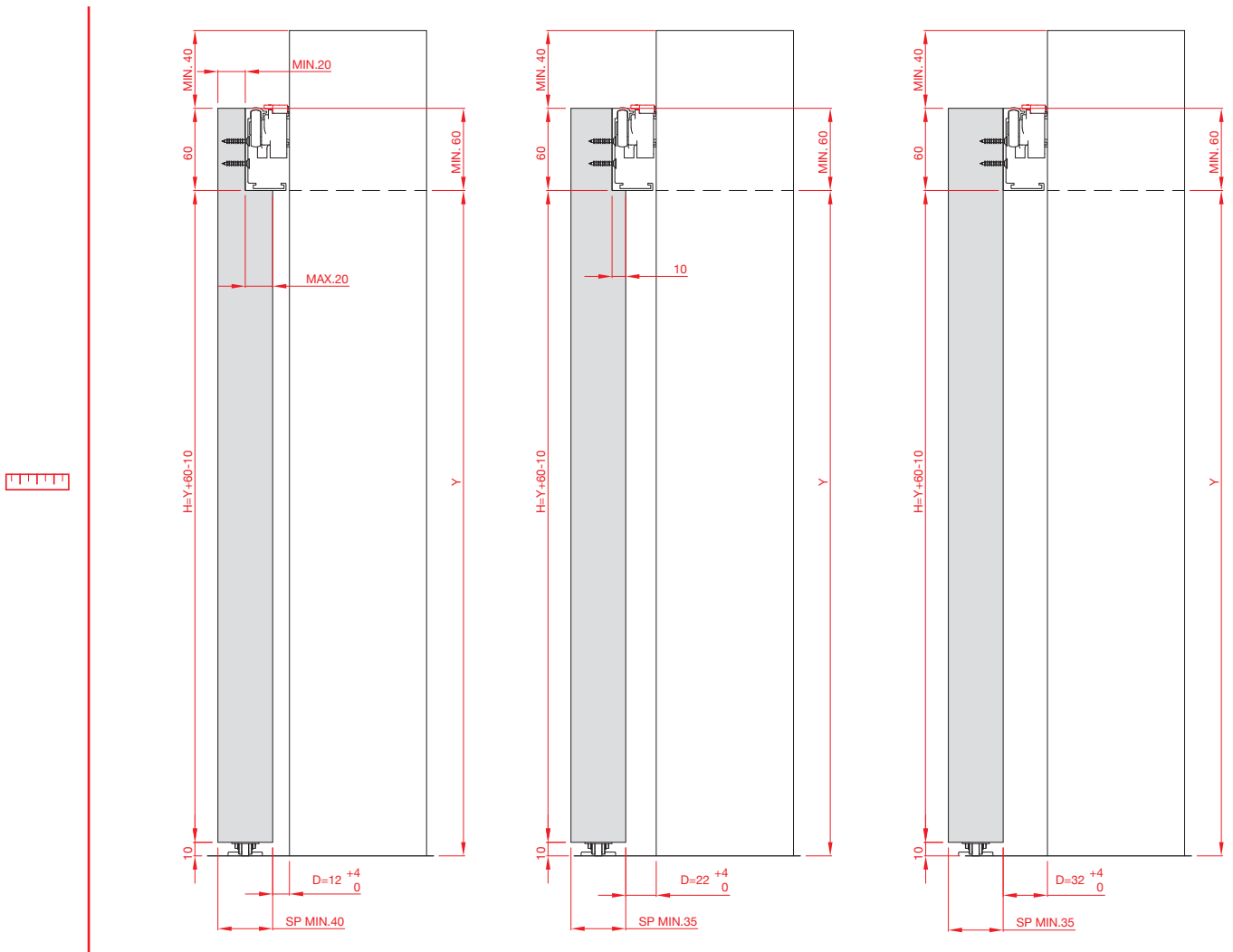

MILLING DESCRIPTION / DESCRIZIONE DELLE LAVORAZIONI

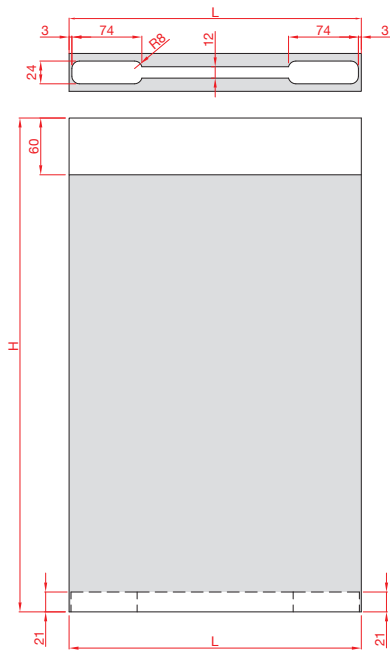

A

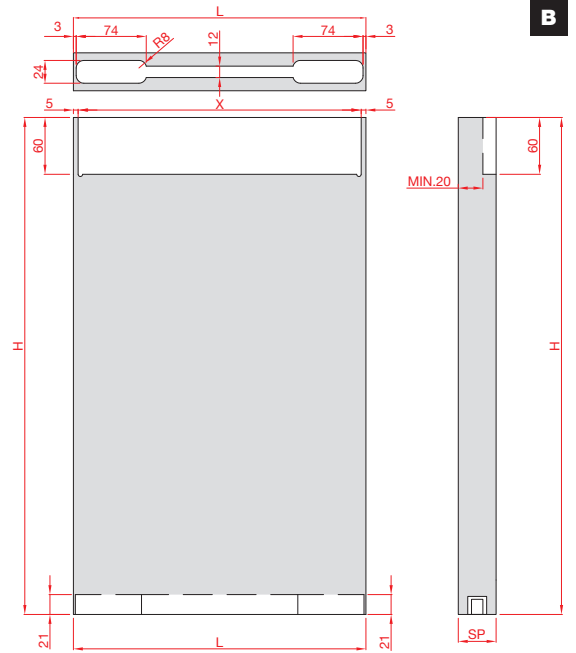

B

HIDDEN MILLED / FRESATA CIECA

PROFILES CUTTING MEASUREMENTS / MISURE DI TAGLIO DEI PROFILI

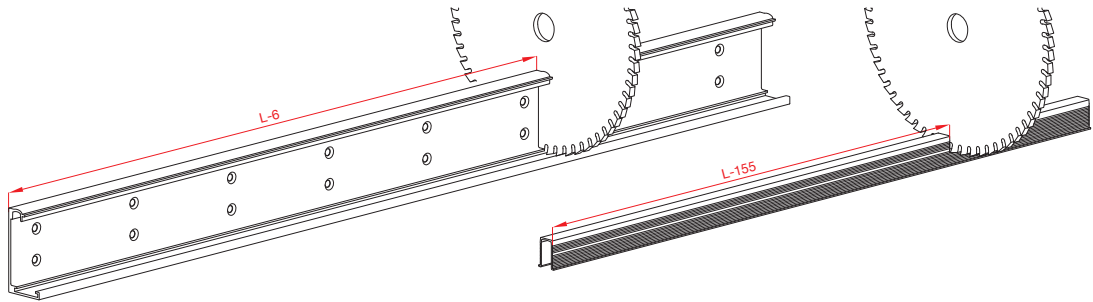

A = L-6
B = L-16

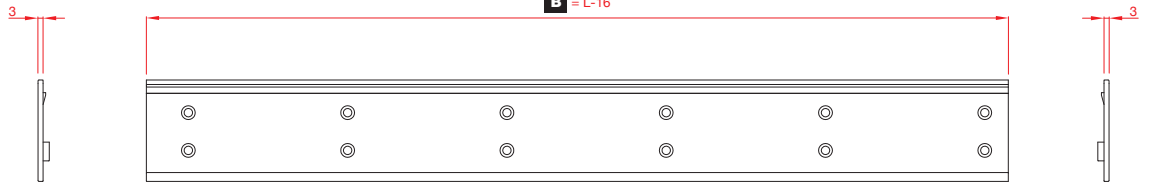

ART. 2851

ART. 2850

ART. 2851

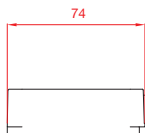

ART. 2858

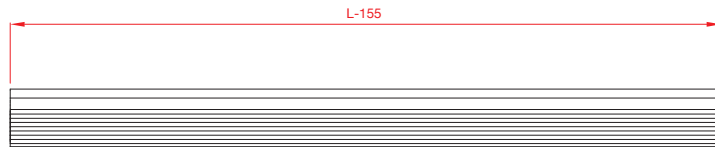

ART. 121

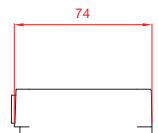

ART. 2858

ACCESSORIES PLACEMENT (STANDARD POSITION) / POSIZIONAMENTO DEGLI ACCESSORI (POSIZIONE STANDARD)

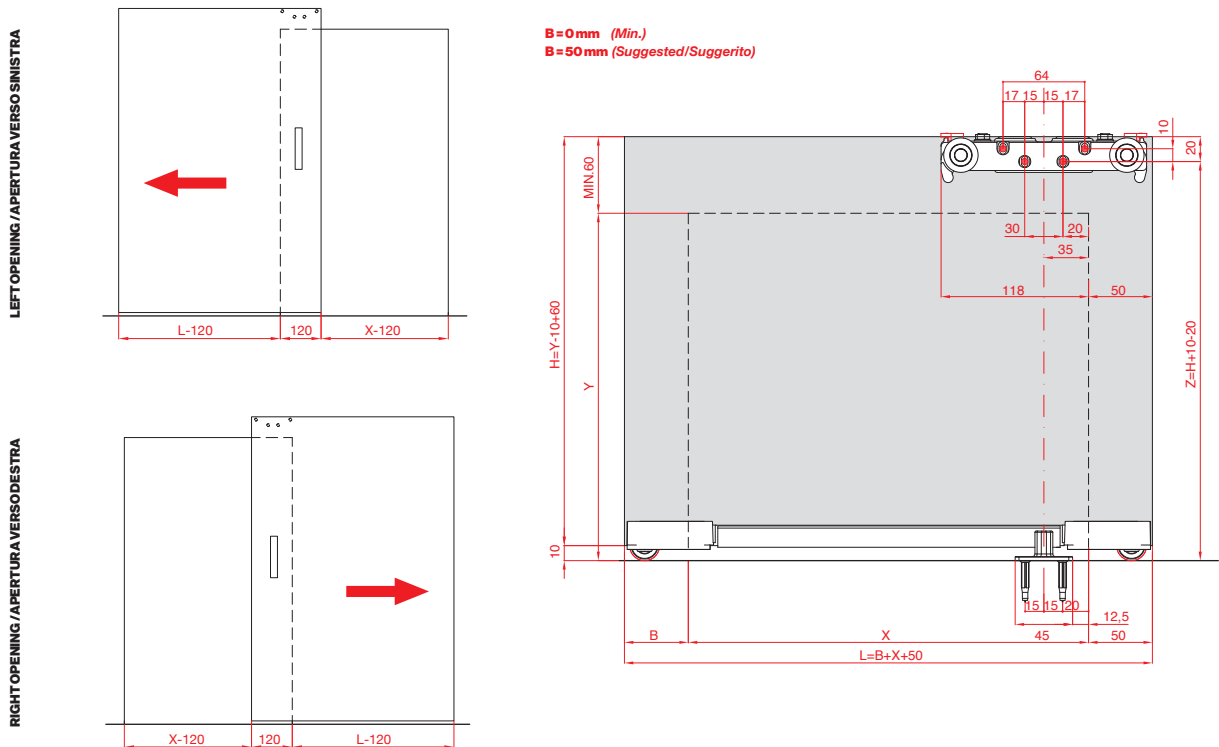

MAGIC2/1100 (K.0031.1.01)

B=0
X= MIN. 800 (L=850)
X= MAX. 1050 (L=1100)

B=50
X= MIN. 800 (L=900)
X= MAX. 1000 (L=1100)

MAGIC2/1800 (K.0031.2.01)

B=0
X= MIN. 800 (L=850)
X= MAX. 1750 (L=1800)

B=50
X= MIN. 800 (L=900)
X= MAX. 1700 (L=1800)

ACCESSORIES PLACEMENT (INTERMEDIATE POSITION) / POSIZIONAMENTO DEGLI ACCESSORI (POSIZIONE INTERMEDIA)

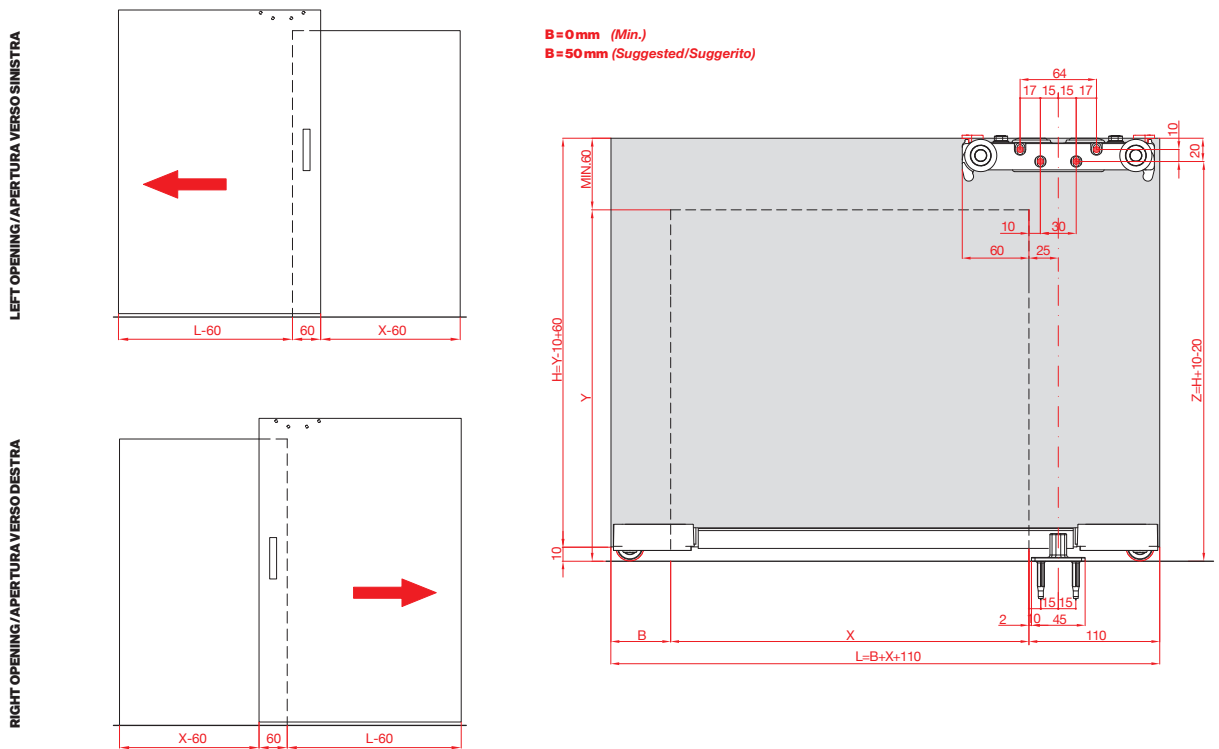

MAGIC2/1100 (K.0031.1.01)

B=0
X= MIN. 740 (L=850)
X= MAX. 990 (L=1100)

B=50
X= MIN. 740 (L=900)
X= MAX. 940 (L=1100)

MAGIC2/1800 (K.0031.2.01)

B=0
X= MIN. 740 (L=850)
X= MAX. 1690 (L=1800)

B=50
X= MIN. 740 (L=900)
X= MAX. 1640 (L=1800)

ACCESSORIES PLACEMENT (TOTAL OPENING POSITION) / POSIZIONAMENTO DEGLI ACCESSORI (POSIZIONE APERTURA TOTALE)

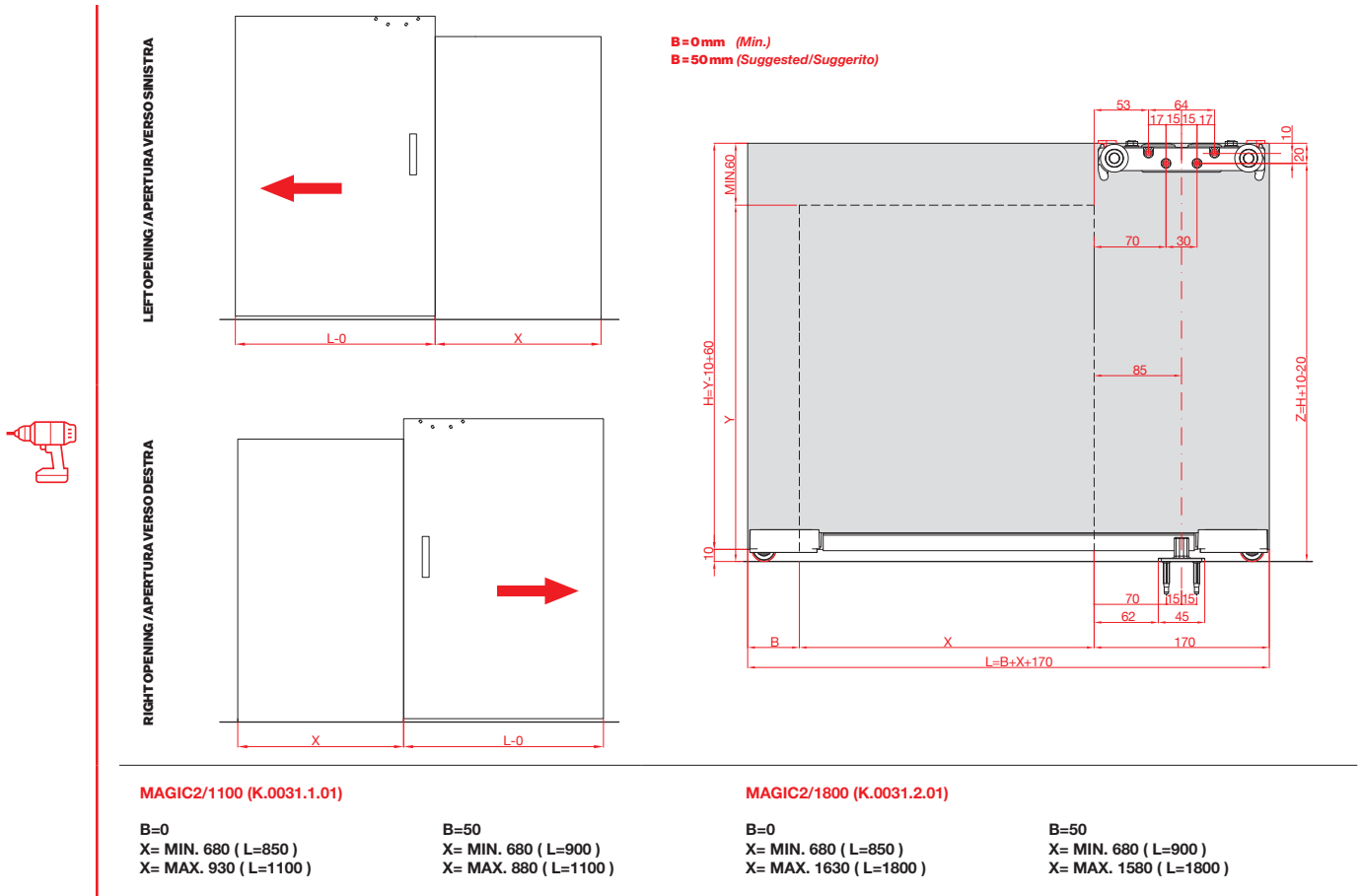

ART. 2859 - END STOPPER / FINE CORSA

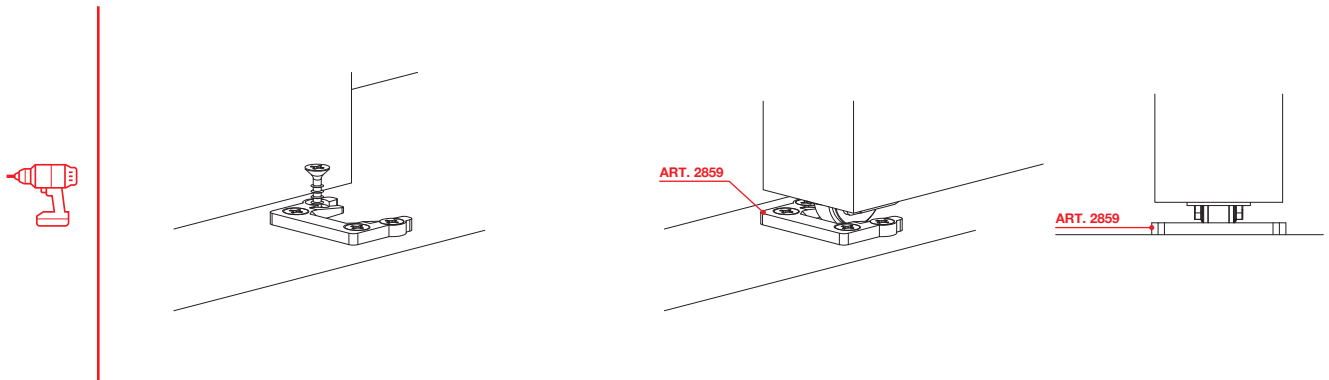

**ALUMINIUM TRACK FOR IRREGULAR FLOOR
PROFILO IN ALLUMINIO PER PAVIMENTAZIONE IRREGOLARE**

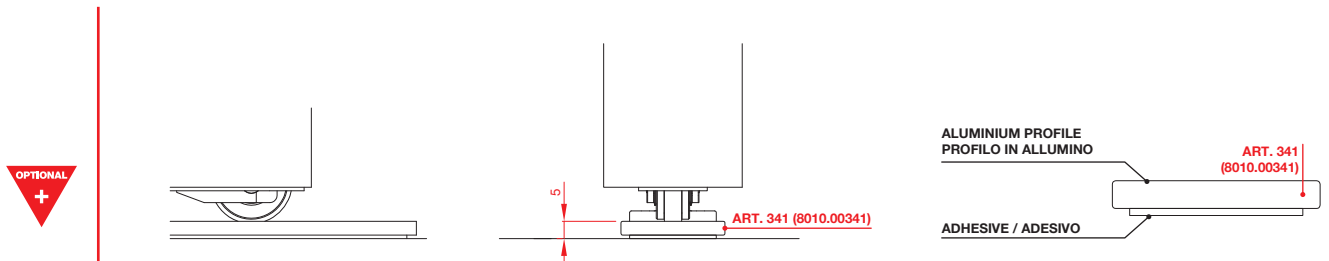

ART. 341
8 01 0 .00341



Magic² Frame

The original invisible sliding doors system
Il sistema invisibile originale per porte scorrevoli



Tracks / Binari

ALUMINUM FINISHES CODES / CODICI FINITURE ALLUMINIO

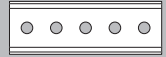

8 ... 0.0

| | | |
|---|---|---|
| 01 • (Anodized Silver / Argento - A) | 13 • (Brushed Anodized Dark Brown / E3 Spazzolato - E3S) | 17 • (Brushed Anodized Nickel / Nichel Spazzolato - NKS) |
| 02 • (Brushed Anodized Silver / Argento Spazzolato - AS) | 14 • (Anodized Black / Nero - N) | 25 • (Brushed Anodized Graphite / Grafite Spazzolato - GRFS) |
| 12 • (Anodized Dark Brown / E3 - E3) | 15 • (Brushed Anodized Black / Nero Spazzolato - NS) | 26 • (Anodized Graphite / Grafite - GRF) |

01 - 02 STANDARD / 12 - 13 - 14 - 15 - 17 - 25 - 26 SPECIAL

Magic2

COMPLETE BOX KIT / KIT COMPLETO IN SCATOLA



K Complete kit / Kit completo

| | | | | | |
|--|--|-------------|----------|---------------------------------|-------------------------------------|
| | | | | | |
| | | 0031 | | Magic2 - Wood Magic2 - Legno | |
| | | | | | |
| | | | 1 | | 1100 mm |
| | | | 2 | | 1800 mm |
| | | | | | |
| | | | | 01 | Standard Finish / Finitura Standard |

Magic2 Frame

COMPLETE BOX KIT / KIT COMPLETO IN SCATOLA



K Complete kit / Kit completo

| | | | | | |
|--|--|-------------|----------|--|--|
| | | | | | |
| | | 0461 | | 1500 mm - 80kg | |
| | | 0462 | | 1100 mm - 80kg | |
| | | | | | |
| | | 1 | | N.2 Soft damper stoppers N.2 Fermi ammortizzati | |
| | | | | | |
| | | | 1 | | 2200 mm |
| | | | 2 | | 2600 mm |
| | | | 3 | | 3000 mm |
| | | | | | |
| | | | | 02 | Brushed Anodized Silver / Argento Spazzolato |
| | | | | 13 | Brushed Anodized Dark Brown / E3 Spazzolato |
| | | | | 15 | Brushed Anodized Black / Nero Spazzolato |
| | | | | 17 | Brushed Anodized Nickel / Nichel Spazzolato |
| | | | | 25 | Brushed Anodized Graphite / Grafite Spazzolato |

Magic2 Vetro

COMPLETE BOX KIT / KIT COMPLETO IN SCATOLA



K Complete kit / Kit completo

| | | | | | |
|--|--|-------------|--|-------------------------------------|--|
| | | | | | |
| | | 0041 | | 1100 mm - 80kg | |
| | | 0042 | | 1800 mm - 80kg | |
| | | | | | |
| | | 1 | | Glass thk. / Vetri sp. 8 mm (5/16") | |
| | | 2 | | Glass thk. / Vetri sp. 10 mm (3/8") | |
| | | 3 | | Glass thk. / Vetri sp. 12 mm (1/2") | |
| | | | | | |
| | | | | 02 | Brushed Anodized Silver / Argento Spazzolato |



Magic2 Mix

COMPLETE BOX KIT / KIT COMPLETO IN SCATOLA

| | | |
|----------|-----------------------------|--|
| K | Complete kit / Kit completo | |
| | . | |
| | 0441 | Magic2 MIX UP |
| | 0442 | Magic2 MIX DOWN |
| | 0443 | Magic2 MIX UP |
| | 0444 | Magic2 MIX DOWN |
| | . | |
| | 1 | 1100 mm → 38-40 mm |
| | 2 | 1800 mm → 38-40 mm |
| | 3 | 1100 mm → 42-44 mm |
| | 4 | 1800 mm → 42-44 mm |
| | . | |
| | 02 | Brushed Anodized Silver / Argento Spazzolato |
| | 15 | Brushed Anodized Black / Nero Spazzolato |



Magic2 Uni

COMPLETE BOX KIT / KIT COMPLETO IN SCATOLA

| | | |
|----------|-----------------------------|--|
| K | Complete kit / Kit completo | |
| | . | |
| | 0451 | 40 mm - 30 kg |
| | 0452 | 44 mm - 30 kg |
| | 0453 | 40 mm - 80 kg |
| | 0454 | 44 mm - 80 kg |
| | . | |
| | 1 | 1100 mm |
| | 2 | 1800 mm |
| | . | |
| | 02 | Brushed Anodized Silver / Argento Spazzolato |
| | 15 | Brushed Anodized Black / Nero Spazzolato |

EXAMPLE / ESEMPIO

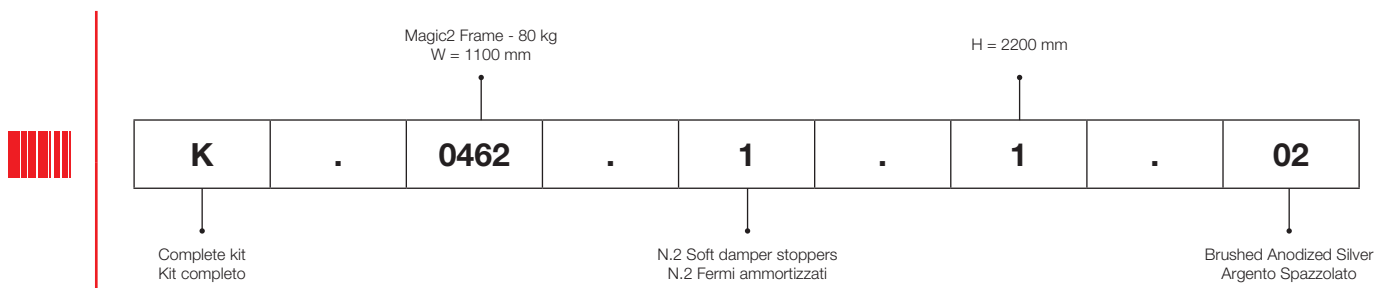

More than 50mm of damping motion

Magic2 system integrates new **PATENTED** dampers with 50 mm of braking motion, 20 mm longer than previous version of **Magic**, while keeping the same door dimensions.

Oltre 50 mm di frenatura

Il sistema **Magic2** integra nuovi fermi ammortizzati **BREVETTATI**, per una frenatura di oltre 50 mm, più di 20 mm rispetto al fermo del modello **Magic**, mantenendo gli stessi ingombri della porta.

PATENTED

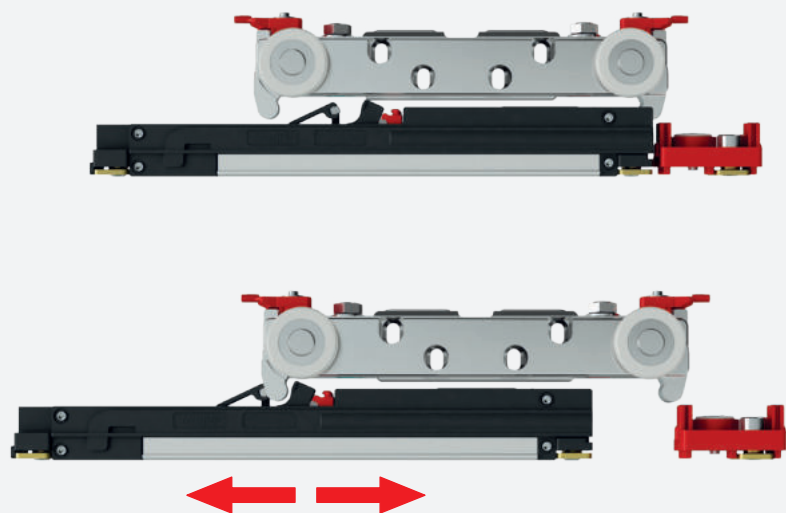
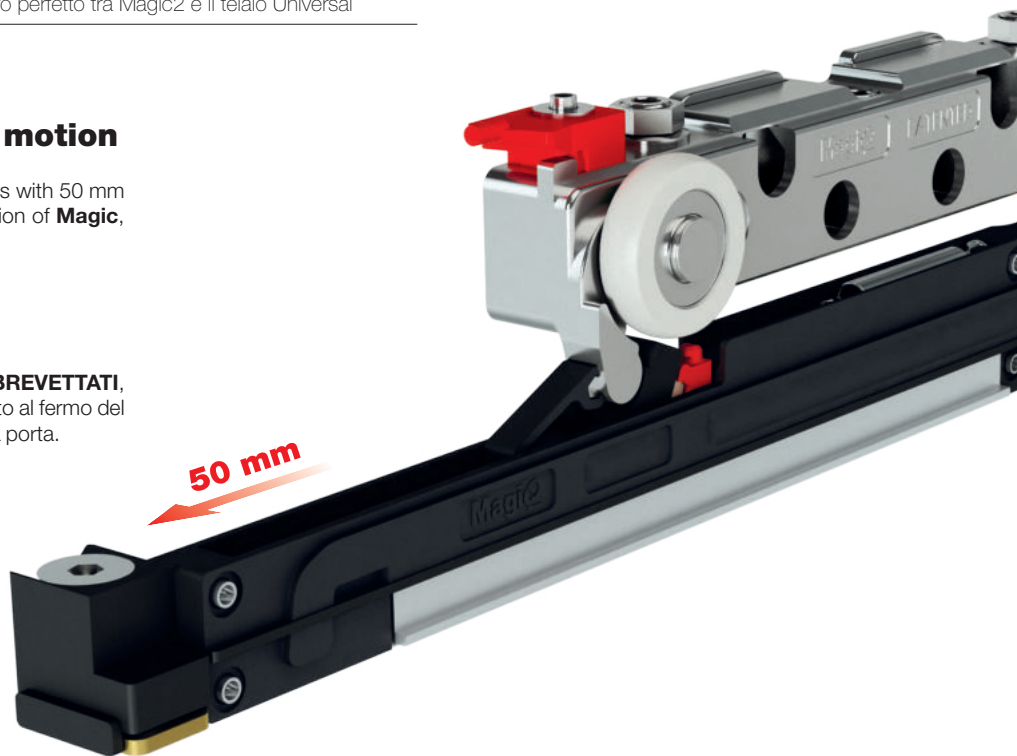

New dampers with adjustable positioning

New **Magic2** adjustable dampers were designed to be independent from wall-spacer wheels. New dampers are suitable to be moved into the track to allow door positioning adjustment.

Nuovi fermi con posizione regolabile

I nuovi fermi del **Magic2** sono stati progettati per essere indipendenti dal distanziale. All'occorrenza si possono spostare per regolare la posizione della porta.

New position of wall-spacer wheels

In **Magic2** system wall-spacer wheels are positioned on the door extremities. The wall-spacer wheels are so positioned in order to protect the door from wall contact, when wall surface are not plane.

Nuova posizione per le ruote distanziali

Nel sistema **Magic2** le ruote distanziali sono posizionate alle estremità della porta. Le ruote distanziali così posizionate proteggono la porta da contatti con la parete, in caso di muri con superfici irregolari.



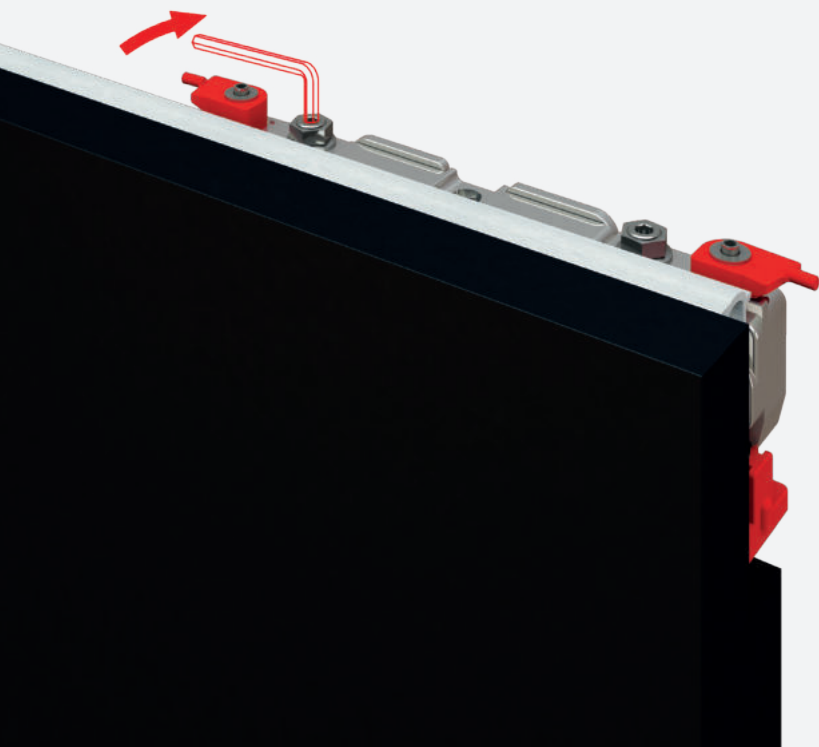

New patented adjustment system

New **Magic² PATENTED** sliding trolley integrates following door adjustments:

- Door height adjustment from floor
- Micrometric adjustment of door from wall
- Micrometric adjustment of door parallelism from wall

Door adjustments of wall distance and parallelism, are meant to compensate possible irregularities of wall. All adjustments are available in the top of sliding trolley, without removing the door.

Nuovo sistema brevettato di regolazione

Il nuovo scorrevole **Magic² BREVETTATO** integra le seguenti regolazioni:

- Regolazione dell'altezza della porta dal pavimento
- Regolazione micrometrica della distanza della porta dalla parete
- Regolazione micrometrica del parallelismo della porta rispetto alla parete

Le regolazioni di distanza e parallelismo della porta, si utilizzano per compensare eventuali irregolarità della parete. Tutte le regolazioni si realizzano dalla parte superiore dello scorrevole, senza sganciare la porta.

Practical anti-jumping system

Magic² sliding trolley includes two new turning anti-jumping activation elements. Turning anti-jumping activation elements are equipped with two safety levers, easy to rotate with no tools required. Safety levers, clearly visible, will have to be removed once anti-jumping system is activated in order to insert end caps.

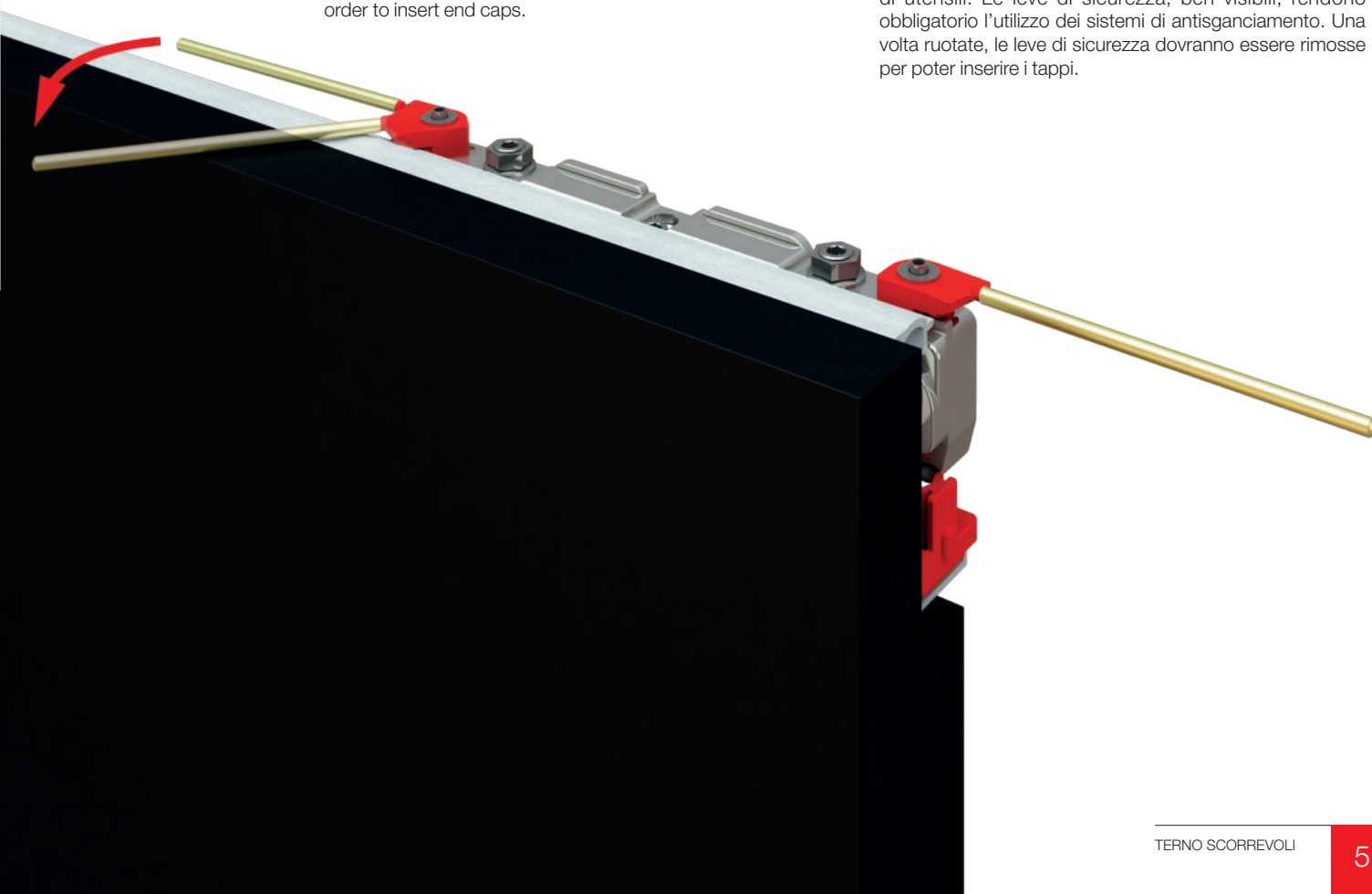

Pratico sistema di antisganciamento

Lo scorrevole **Magic²** comprende due nuovi elementi rotanti di antisganciamento. In questi nuovi elementi sono inserite due leve di sicurezza, per ruotarli senza l'utilizzo di utensili. Le leve di sicurezza, ben visibili, rendono obbligatorio l'utilizzo dei sistemi di antisganciamento. Una volta ruotate, le leve di sicurezza dovranno essere rimosse per poter inserire i tappi.

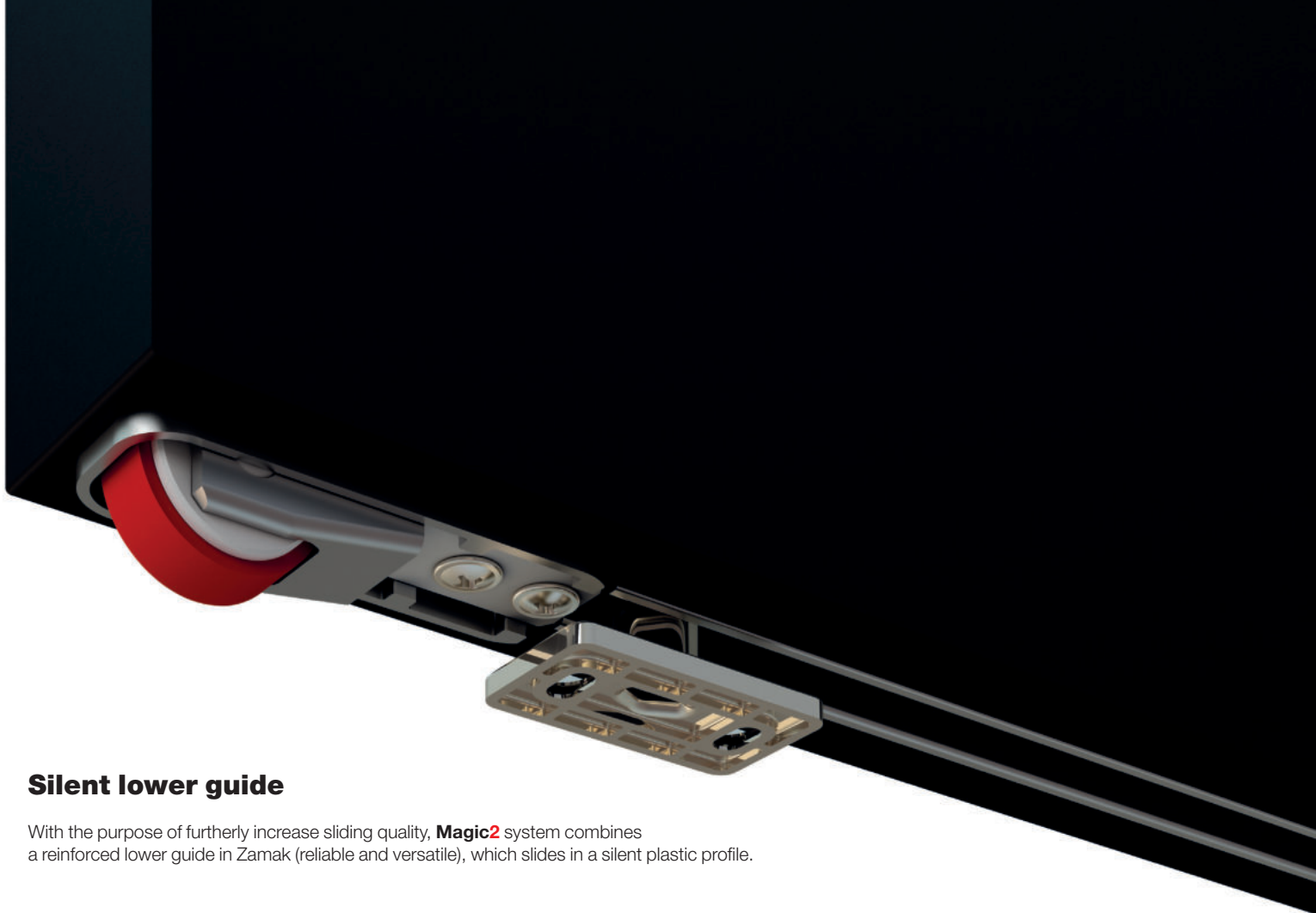

Silent lower guide

With the purpose of furtherly increase sliding quality, **Magic2** system combines a reinforced lower guide in Zamak (reliable and versatile), which slides in a silent plastic profile.

Guida inferiore silenziosa

Per migliorare ancor di più lo scorrimento, il sistema **Magic2** integra una guida inferiore rinforzata in zama (resistente e versatile), che scorre in un profilo in plastica molto silenzioso.

New patented bottom wheels designed for a better sliding

New **Magic2** bottom wheels are equipped with a **PATENTED** suspension spring system and were designed with a larger diameter, bigger bearing and steel pivots. Rubber surface have been enlarged as well, in order to reinforce wheels and improve sliding quality.

An additional important **PATENTED** innovation in lower sliding system is the introduction of two padded fixed springs which can grant damping function during door motion up to 40kg. Over 40kg of door weight and up to 80kg of maximum load capacity, new bottom wheels will be more flexible than previous version, with their Zamak surface to lean on a rubber internal cylinder, which act as a small shock absorber, granting more stability during sliding motion.

The **Magic2** wheels rubber have high performance:

- it does not leave any trace or sign on sliding surface like floors and walls
- it does not deform over time

Ruote inferiori brevettate per una migliore scorrevolezza

Le nuove ruote inferiori del sistema **Magic2** hanno molleggio **BREVETTATO**, e sono state progettate con diametro, cuscinetti e perni in acciaio maggiorati. Anche il rivestimento in gomma è stato raddoppiato per aumentare la forza e la scorrevolezza delle ruote.

Un'altra importante innovazione **BREVETTATA** nel sistema di scorrimento inferiore è l'inserimento di due molle fisse maggiorate che permettono di ammortizzare il movimento della porta fino ad una portata di 40 kg. Oltre i 40 kg, e fino ad un massimo di 80 kg, queste nuove ruote flettono maggiormente e la superficie realizzata in zama si appoggia su di un cilindro di gomma interno che funge da ammortizzatore supplementare garantendo maggior stabilità.

La gomma delle ruote di **Magic2** è altamente performante:

- non lascia traccia sulle superfici di scorrimento come pavimenti e pareti
- non si deforma nel tempo

KG 0 < KG 40

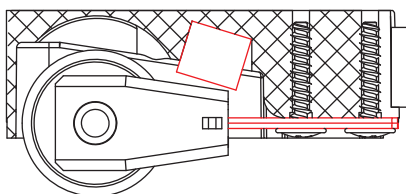

KG 40 < KG 80

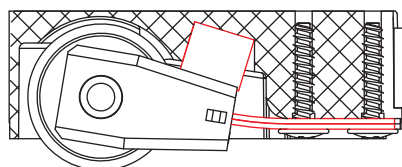

Built-in sliding track with not-through milling

Upper sliding track can be installed "built-in" into a blind milling. Laterally, track's end caps won't be visible, improving even more the aesthetics of door. Door installation and adjustment are not going to be different than usual, because available on the top of the door.

Binario incassato in fresata non passante

Il binario superiore può essere incassato in una fresata cieca. Lateralmente non saranno visibili i tappi del binario, migliorando ulteriormente l'estetica della porta. L'installazione e regolazione della porta non variano perché le regolazioni si effettuano dal lato superiore della porta.

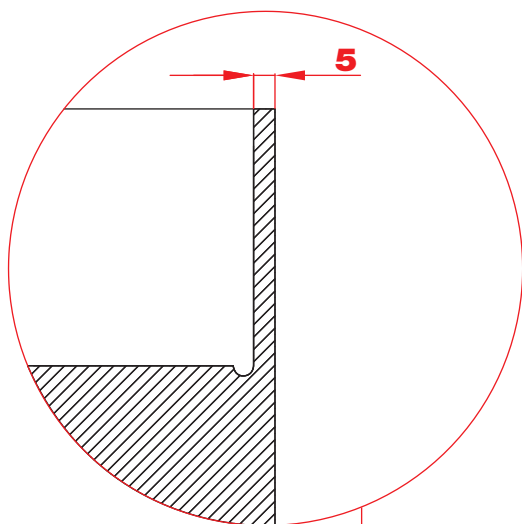

Magic2 Frame

PATENTED

Magic2 Frame combines the innovative features of invisible sliding door system **Magic2** with the versatility and clean design of our new **Universal** frame, which allows clean lines, reduced encumbrances and maximal resistance.

Magic2 Frame, designed for glasses in 5 and 6,5 mm thickness, it is therefore the perfect meeting point between functionality and design.

Magic2 Frame unisce le caratteristiche innovative del sistema invisibile per porte scorrevoli **Magic2** alla versatilità e al design pulito del nostro telaio **Universal**, che offre linee pulite, ingombri ridotti e la massima resistenza.

Magic2 Frame è quindi il perfetto punto d'incontro tra funzionalità e design, ed è progettato per vetri con spessori da 5 a 6,5 mm.





Minimal and linear design, with the highest resistance

The vertical upright with reduced dimensions will decrease visibility of extruded profiles. The lines will then result linear and clean. The gap, in the upper side of the door as in the bottom's, is reduced out just like standard swing doors and no additional drilling or milling processing are needed. The sliding track external cover will shape with the door a continuous surface: everything contributes to confer to new **Universal** frame a minimal, but pleasant design.

Tubular extruded profiles, metal joints, maximal grip, load-bearing connectors, bi-extruded gaskets: All components contribute to grant the glass weight to be sustained by vertical uprights and horizontal crosstracks, halving the pressure of it.

Design pulito e lineare, con la massima resistenza

Il montante verticale con dimensioni ridotte riduce la visibilità degli estrusi. Le linee risultano così lineari e pulite. La luce, sia nella parte alta che nella parte bassa della porta, è ridotta al pari di una porta battente. Non sono necessarie lavorazioni di foratura e fresatura. La copertura in alluminio e la porta formano una superficie continua: tutto concorre a conferire al nuovo telaio **Universal** un design essenziale ma piacevole.

Estrusi tubolari, giunzioni in metallo, aderenza massima, attacchi portanti, guarnizione biestrusa: il peso del vetro è sostenuto dai montanti e dai traversi, e ne viene dimezzata la pressione.

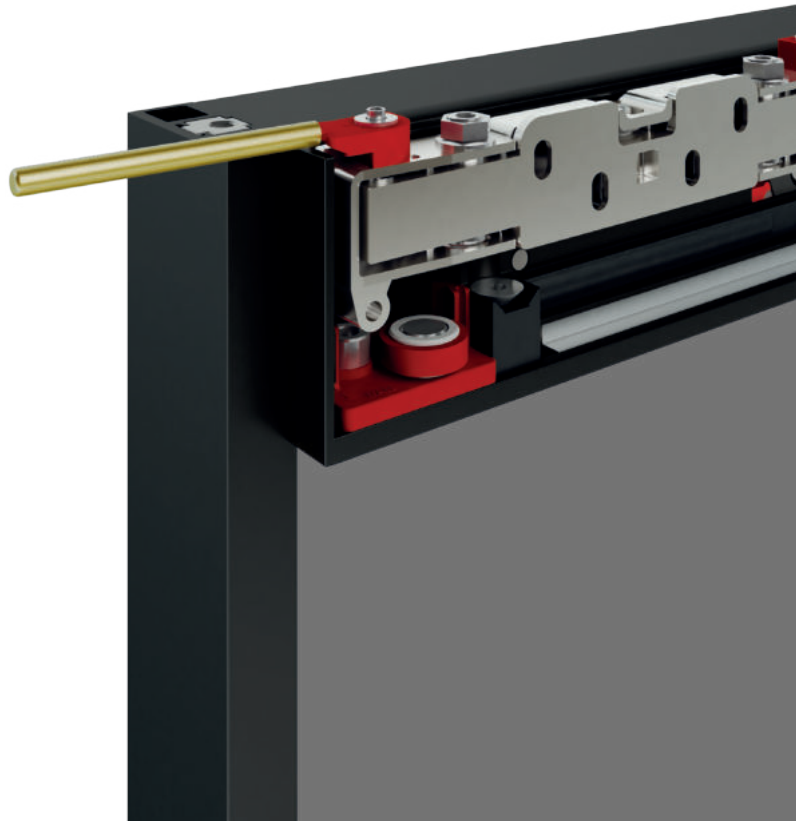

“The new UNIVERSAL frame is the perfect answer to the demand of an elegant, performant and high resistant product”

“Il nuovo telaio UNIVERSAL è la risposta perfetta alle richieste di un prodotto elegante ma funzionale, e resistente”

Versatility and resistance

The new **Universal** frame's extruded profiles are tubular in order to grant maximum resistance and are assembled by metal joint connectors, without any additional drilling precessing requirement: This allows to cut profile's bars to favourite size, with no additional drilling or milling precess, always granting the best grip.

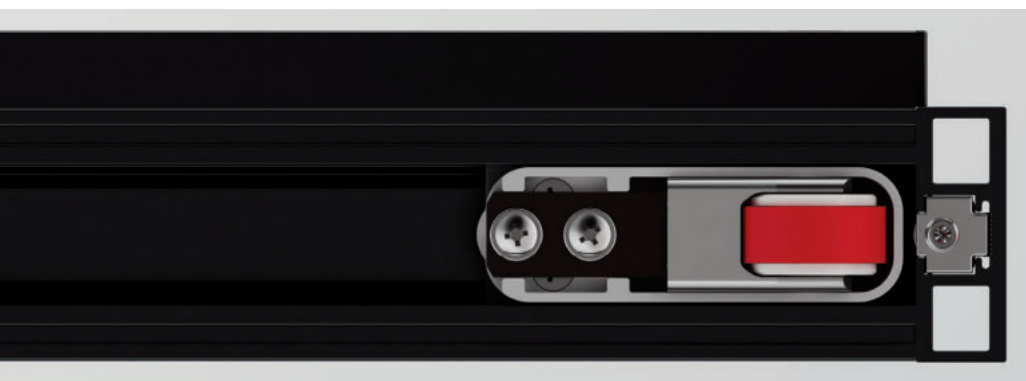

Resistenza e flessibilità

I nuovi estrusi del telaio **Universal** sono tubolari, per ottenere la massima resistenza, e vengono assemblati tramite giunzione in metallo, senza necessità di lavorazioni di foratura: questo permette di tagliare la barra nella misura preferita, senza fori nè fresate, e di ottenere la massima aderenza.

Essential and modern design

The vertical upright has been designed with reduced dimensions in order to extremely limitate the visual impact of extruded profiles. The sliding track's external aluminium cover aligned with the door, it is shaping a continuous and pleasant line. Profiles and accessories are available in different finishings, from lighter to darker colours, as per latest design trends.

Design essenziale e moderno

Il montante verticale ha dimensioni ridotte per limitare estremamente la visibilità degli estrusi. La copertura in alluminio e la porta formano una superficie continua, piacevole alla vista. I profili e gli accessori possono inoltre essere realizzati con diversi tipi di finiture, dai colori più chiari fino a colorazioni più scure, di tendenza.

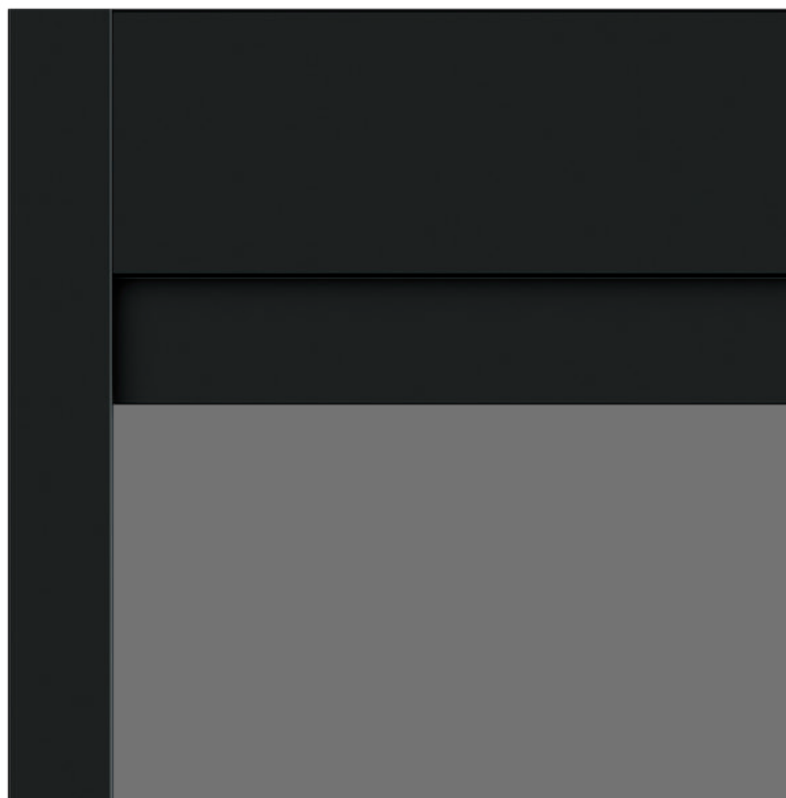

Reduced vertical and horizontal gap

Into the horizontal crosstrack are inserted dustcover brushes, allowing to fill the gap either in the bottom, as in the upper side, towards the external cover. According to that, horizontal or vertical door's gap will result extremely reduced.

Spazio di aria e di luce ridotti

Nel montante orizzontale vengono inseriti gli spazzolini parapolvere, che permettono di chiudere la luce sia nella parte inferiore che nella parte superiore, verso la copertura: lo spazio di aria e di luce risultano così estremamente ridotti.

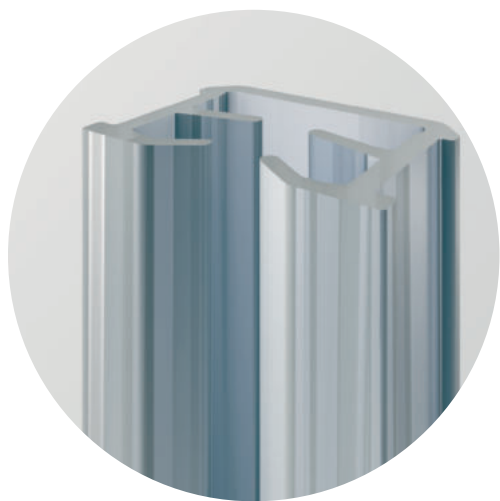

Dedicated to monolithic and laminated glass

Thanks to innovative extruded profiles, **Universal** frame result to be highly resistant. Furthermore, it has been realized an innovative bi-extruded gasket which allows an optimal grip of glass. The bi-extruded gasket will allow to use monolithic and laminated glasses from 5 up to 6,5 mm thickness.

Per vetri monolitici o stratificati

Grazie agli innovativi estrusi, il telaio **Universal** risulta molto resistente. È stata realizzata, inoltre, un'innovativa guarnizione biestrusa che permette un'ottimale tenuta del vetro. Con questa guarnizione, è possibile montare vetri monolitici o laminati con spessori da 5 a 6,5 mm.

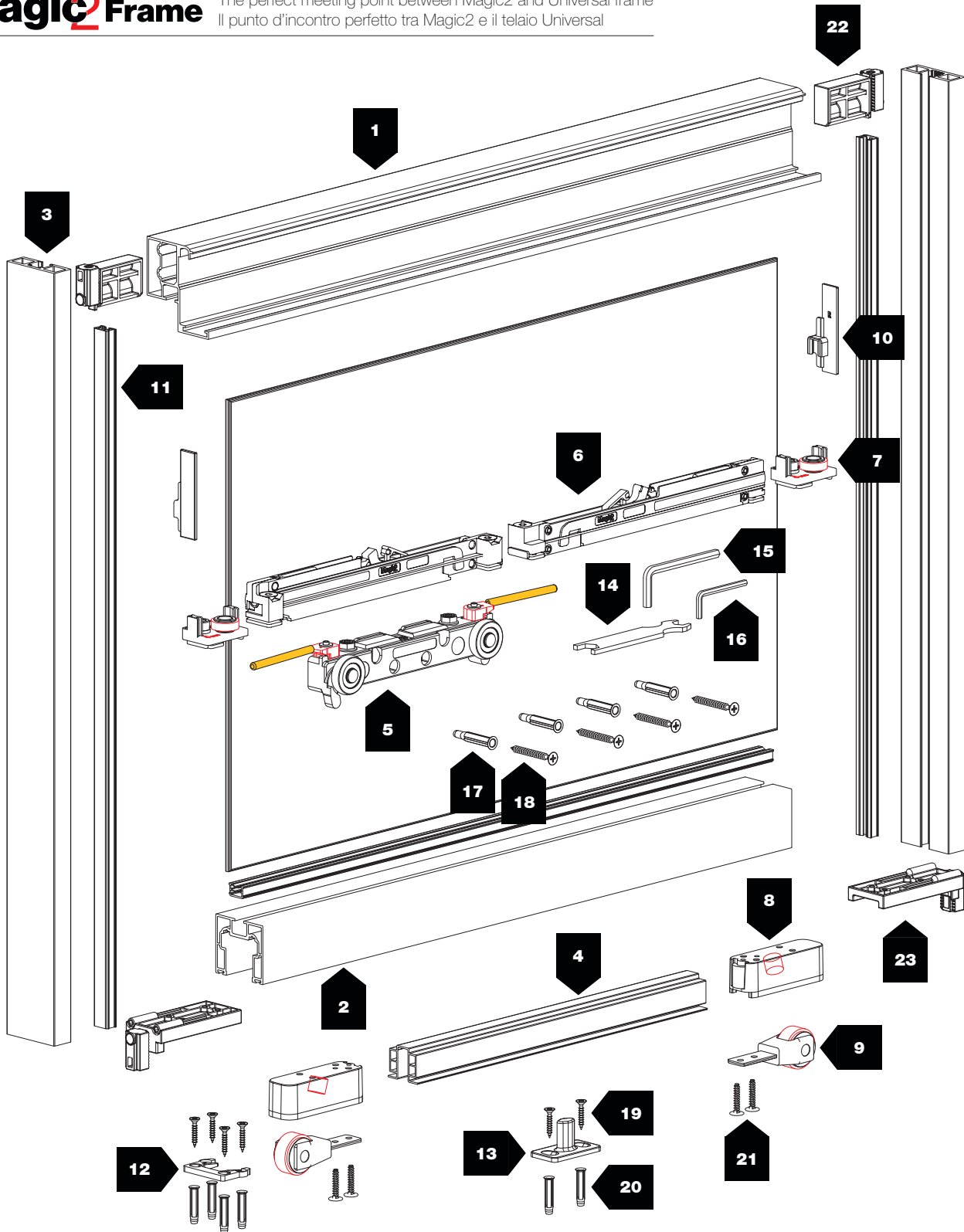

1100 - 1500 mm



80 kg



10 mm

COLORS / COLORI



Brushed Anodized Silver
Argento Spazzolato



Brushed Anodized Nickel
Nichel Spazzolato



Brushed Anodized Graphite
Grafite Spazzolato



Brushed Anodized Dark Brown
E3 Spazzolato



Brushed Anodized Black
Nero Spazzolato

| N° | Barcode | Image | kg | | N° | Barcode | Image | kg | |
|----|---------|-------|----|--|----|--------------------|-------|----|--|
| 1 | 2780 | | — | | 13 | 2855 | | — | |
| 2 | 2778 | | — | | 14 | 1025 | | — | |
| 3 | 2761 | | — | | 15 | 538 | | — | |
| 4 | 2860 | | — | | 16 | 654 | | — | |
| 5 | 2852 | | 80 | | 17 | FISCHER UX6 | | — | |
| 6 | 2864-80 | | 80 | | 18 | 4,5x40 | | — | |
| 7 | 2856 | | — | | 19 | 4x30 | | — | |
| 8 | 2858 | | 80 | | 20 | FISCHER SX5 | | — | |
| 9 | 2857 | | 80 | | 21 | 4x20 | | — | |
| 10 | 2899 | | — | | 22 | 2774_DX 2774_SX | | 80 | |
| 11 | 2766 | | — | | 23 | 2776 | | 80 | |
| 12 | 2859 | | — | | | | | | |



80 kg



N.2 Soft damper stoppers
N.2 Fermi ammortizzati



Customizable door width
Larghezza porta personalizzabile



Patented system
Sistema brevettato

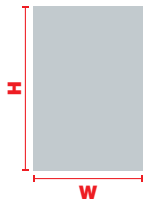
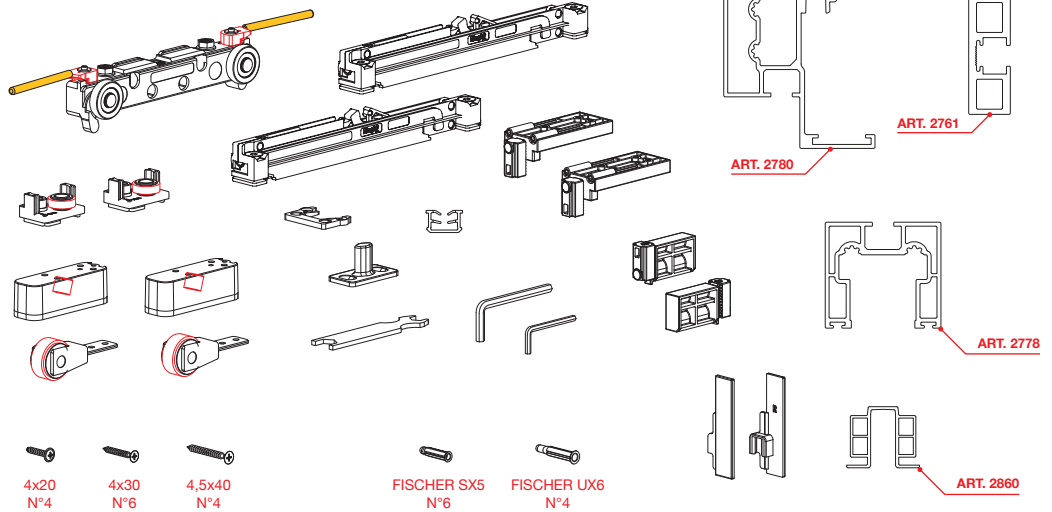

| W | H | CODE | COLOURS / COLORI | | | | | MIN |
|---------|---------|------------|------------------|-----|------|-----|-----|-----|
| | | | AS | NKS | GRFS | E3S | NS | |
| 1100 mm | 2200 mm | K.0462.1.1 | .02 | .17 | .25 | .13 | .15 | 1x |
| | 2600 mm | K.0462.1.2 | .02 | .17 | .25 | .13 | .15 | 1x |
| | 3000 mm | K.0462.1.3 | .02 | .17 | .25 | .13 | .15 | 1x |
| 1500 mm | 2200 mm | K.0461.1.1 | .02 | .17 | .25 | .13 | .15 | 1x |
| | 2600 mm | K.0461.1.2 | .02 | .17 | .25 | .13 | .15 | 1x |
| | 3000 mm | K.0461.1.3 | .02 | .17 | .25 | .13 | .15 | 1x |

MEASUREMENTS DESCRIPTION / DESCRIZIONE MISURE

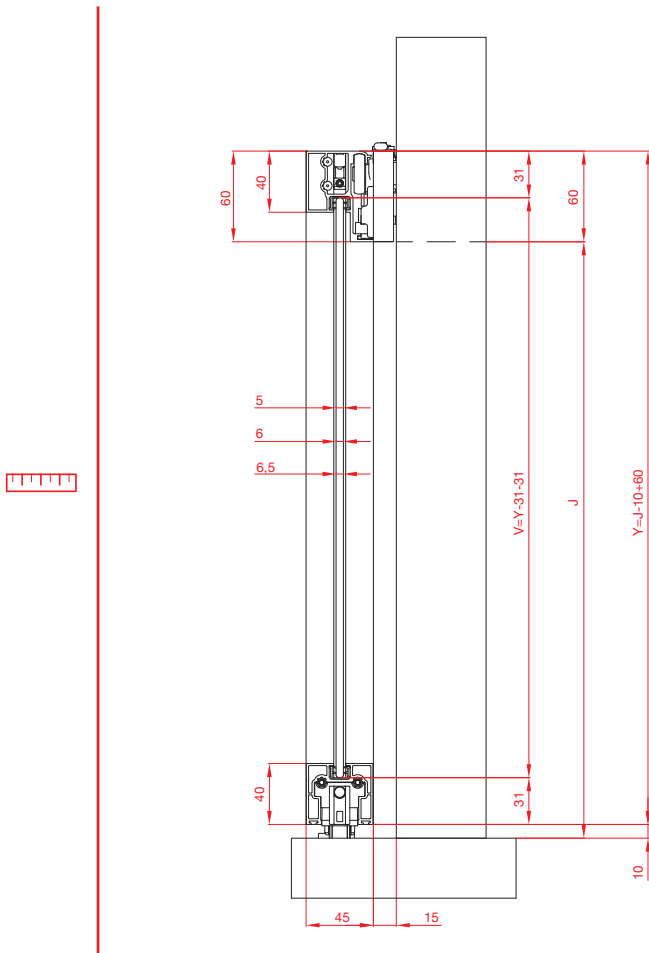

GLASS SIZE CALCULATION TABLE / CALCOLO VETRO

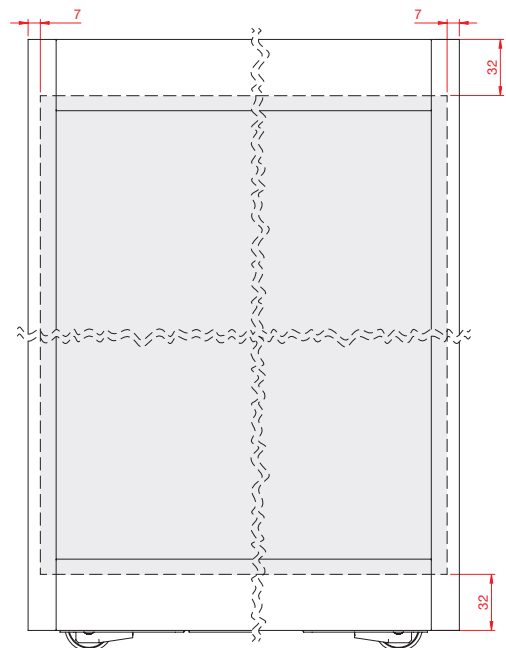

PROFILES CUTTING MEASUREMENTS / MISURE DI TAGLIO DEI PROFILI

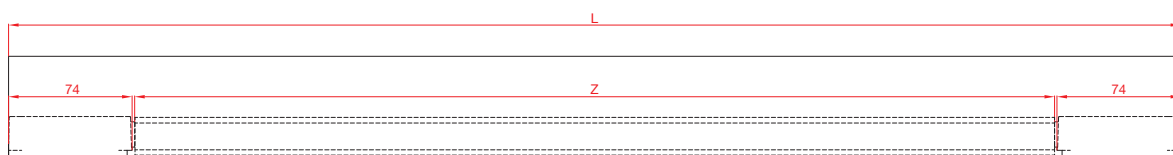
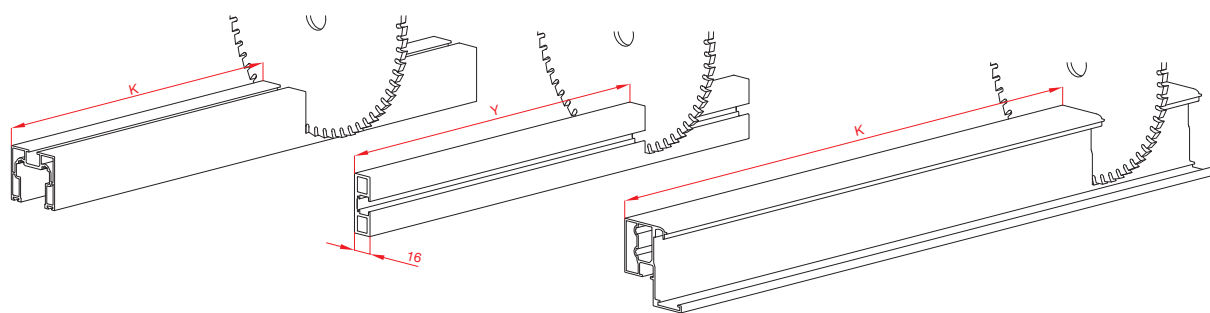

ART. 2858

ART. 2858

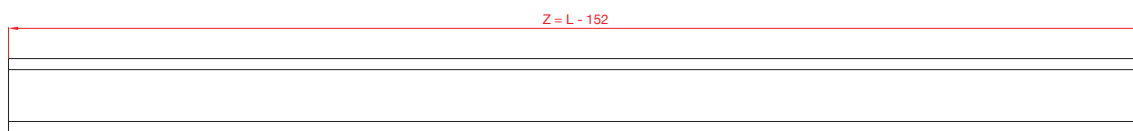

ART. 2860

ACCESSORIES PLACEMENT (STANDARD POSITION) / POSIZIONAMENTO DEGLI ACCESSORI (POSIZIONE STANDARD)

LEFT OPENING / APERTURA VERSO SINISTRA

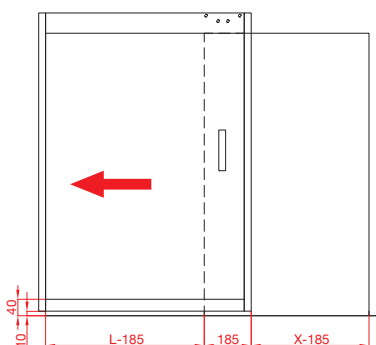

RIGHT OPENING / APERTURA VERSO DESTRA

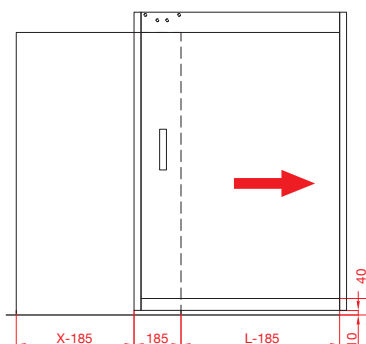

X = Min. 818 mm (L = 850)
 X = Max. 1468 mm (L = 1500)

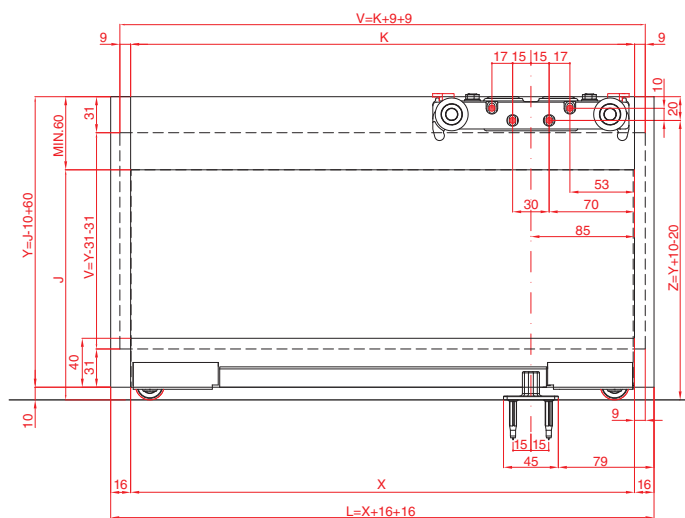

ACCESSORIES PLACEMENT (INTERMEDIATE POSITION) / POSIZIONAMENTO DEGLI ACCESSORI (POSIZIONE INTERMEDIA)



LEFT OPENING / APERTURA VERSO SINISTRA

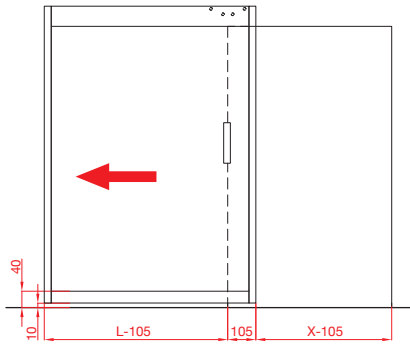

RIGHT OPENING / APERTURA VERSO DESTRA

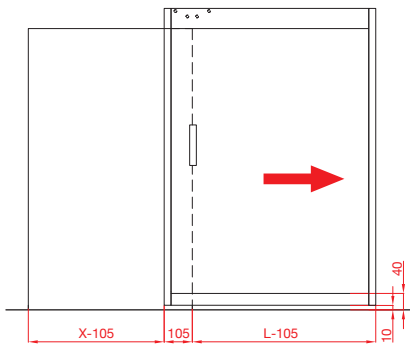

X = Min. 733 mm (L = 850)
X = Max. 1383 mm (L = 1500)

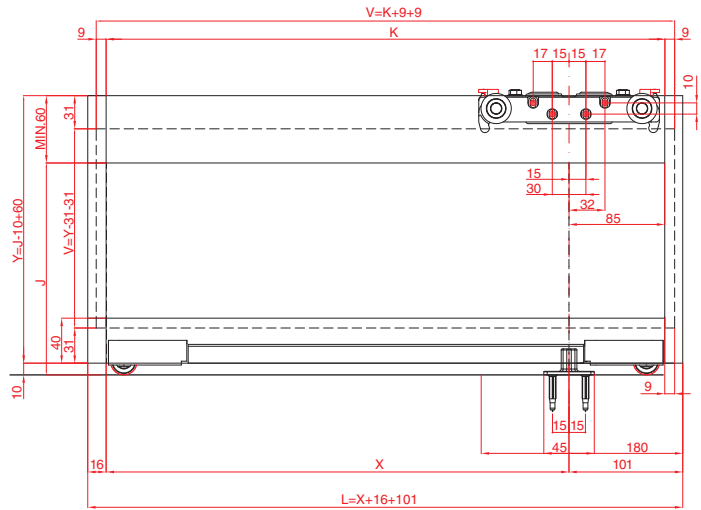

ACCESSORIES PLACEMENT (TOTAL OPENING POSITION) / POSIZIONAMENTO DEGLI ACCESSORI (POSIZIONE APERTURA TOTALE)



LEFT OPENING / APERTURA VERSO SINISTRA

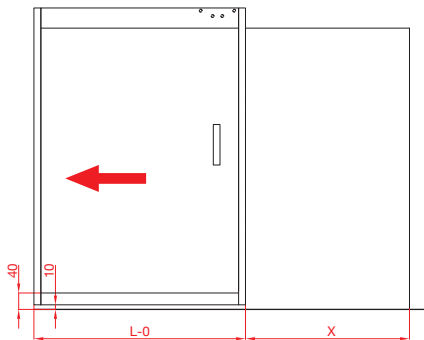

RIGHT OPENING / APERTURA VERSO DESTRA

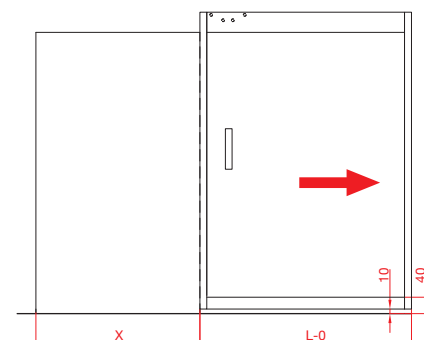

X = Min. 632 mm (L = 850)
X = Max. 1282 mm (L = 1500)

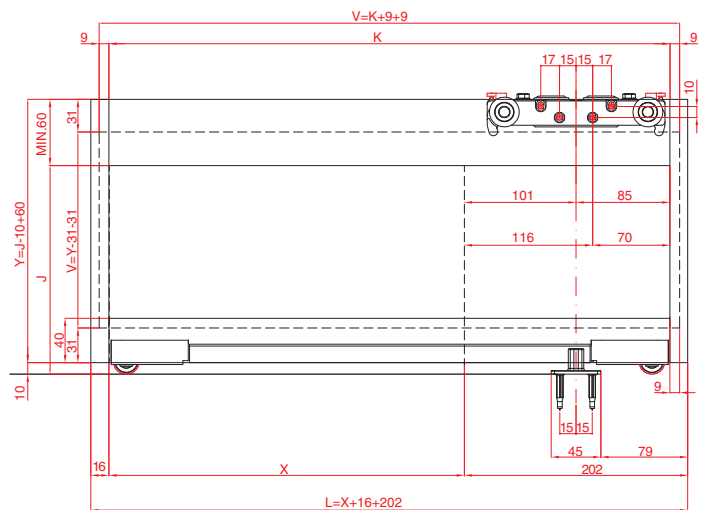

ART. 2859 - END STOPPER / FINE CORSA

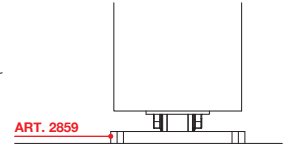
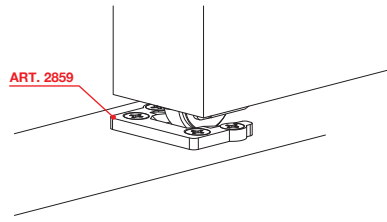
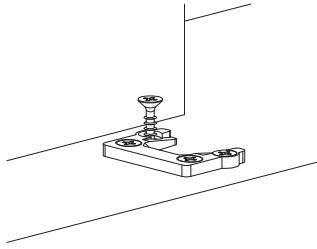

ALUMINIUM TRACK FOR IRREGULAR FLOOR PROFILO IN ALLUMINIO PER PAVIMENTAZIONE IRREGOLARE

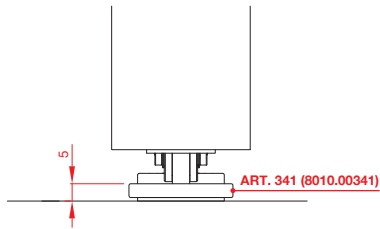
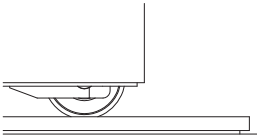

ALUMINIUM PROFILE
PROFILO IN ALLUMINIO

ART. 341
(8010.00341)

ADHESIVE / ADESIVO

ART. 341
8 01 0 .00341



Magic² Mix Down

The original invisible sliding doors system
Il sistema invisibile originale per porte scorrevoli



Tracks / Binari

ALUMINUM FINISHES CODES / CODICI FINITURE ALLUMINIO



8 ... 0.0

| | | |
|---|---|---|
| 01 • (Anodized Silver / Argento - A) | 13 • (Brushed Anodized Dark Brown / E3 Spazzolato - E3S) | 17 • (Brushed Anodized Nickel / Nichel Spazzolato - NKS) |
| 02 • (Brushed Anodized Silver / Argento Spazzolato - AS) | 14 • (Anodized Black / Nero - N) | 25 • (Brushed Anodized Graphite / Grafite Spazzolato - GRFS) |
| 12 • (Anodized Dark Brown / E3 - E3) | 15 • (Brushed Anodized Black / Nero Spazzolato - NS) | 26 • (Anodized Graphite / Grafite - GRF) |

01 - 02 STANDARD / 12 - 13 - 14 - 15 - 17 - 25 - 26 SPECIAL

Magic2

COMPLETE BOX KIT / KIT COMPLETO IN SCATOLA



K Complete kit / Kit completo

| | | |
|------|--|-------------------------------------|
| 0031 | | Magic2 - Wood Magic2 - Legno |
| 1 | | 1100 mm |
| 2 | | 1800 mm |
| 01 | | Standard Finish / Finitura Standard |

Magic2 Frame

COMPLETE BOX KIT / KIT COMPLETO IN SCATOLA



K Complete kit / Kit completo

| | | |
|------|--|--|
| 0461 | | 1500 mm - 80kg |
| 0462 | | 1100 mm - 80kg |
| 1 | | N.2 Soft damper stoppers N.2 Fermi ammortizzati |
| 1 | | 2200 mm |
| 2 | | 2600 mm |
| 3 | | 3000 mm |
| 02 | | Brushed Anodized Silver / Argento Spazzolato |
| 13 | | Brushed Anodized Dark Brown / E3 Spazzolato |
| 15 | | Brushed Anodized Black / Nero Spazzolato |
| 17 | | Brushed Anodized Nickel / Nichel Spazzolato |
| 25 | | Brushed Anodized Graphite / Grafite Spazzolato |

Magic2 Vetro

COMPLETE BOX KIT / KIT COMPLETO IN SCATOLA















K Complete kit / Kit completo

| | | |
|------|--|--|
| 0041 | | 1100 mm - 80kg |
| 0042 | | 1800 mm - 80kg |
| 1 | | Glass thk. / Vetri sp. 8 mm (5/16") |
| 2 | | Glass thk. / Vetri sp. 10 mm (3/8") |
| 3 | | Glass thk. / Vetri sp. 12 mm (1/2") |
| 02 | | Brushed Anodized Silver / Argento Spazzolato |

Magic2 Mix

COMPLETE BOX KIT / KIT COMPLETO IN SCATOLA









| | | |
|----------|-----------------------------|--|
| K | Complete kit / Kit completo | |
| | . | |
| | 0441 |  Magic2 MIX UP |
| | 0442 |  Magic2 MIX DOWN |
| | 0443 |  Magic2 MIX UP |
| | 0444 |  Magic2 MIX DOWN |
| | . | |
| | 1 |  1100 mm →  38-40 mm |
| | 2 |  1800 mm →  38-40 mm |
| | 3 |  1100 mm →  42-44 mm |
| | 4 |  1800 mm →  42-44 mm |
| | . | |
| | 02 | Brushed Anodized Silver / Argento Spazzolato |
| | 15 | Brushed Anodized Black / Nero Spazzolato |

Magic2 Uni

COMPLETE BOX KIT / KIT COMPLETO IN SCATOLA



| | | |
|----------|-----------------------------|--|
| K | Complete kit / Kit completo | |
| | . | |
| | 0451 |  40 mm - 30 kg |
| | 0452 |  44 mm - 30 kg |
| | 0453 |  40 mm - 80 kg |
| | 0454 |  44 mm - 80 kg |
| | . | |
| | 1 |  1100 mm |
| | 2 |  1800 mm |
| | . | |
| | 02 | Brushed Anodized Silver / Argento Spazzolato |
| | 15 | Brushed Anodized Black / Nero Spazzolato |

EXAMPLE / ESEMPIO

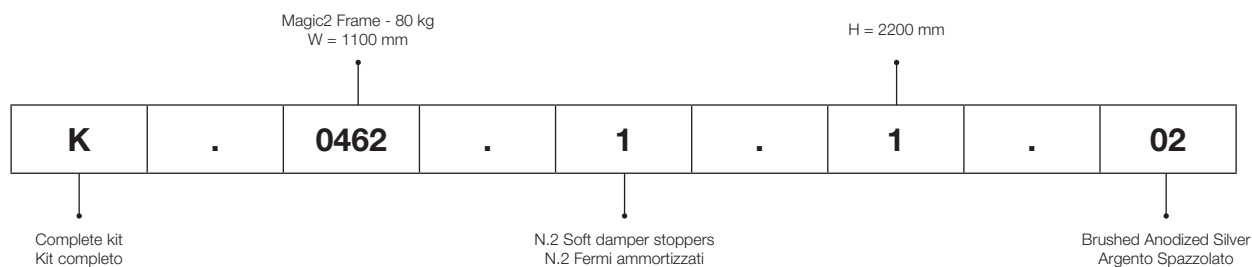

More than 50mm of damping motion

Magic² system integrates new **PATENTED** dampers with 50 mm of braking motion, 20 mm longer than previous version of **Magic**, while keeping the same door dimensions.

Oltre 50 mm di frenatura

Il sistema **Magic²** integra nuovi fermi ammortizzati **BREVETTATI**, per una frenatura di oltre 50 mm, più di 20 mm rispetto al fermo del modello **Magic**, mantenendo gli stessi ingombri della porta.

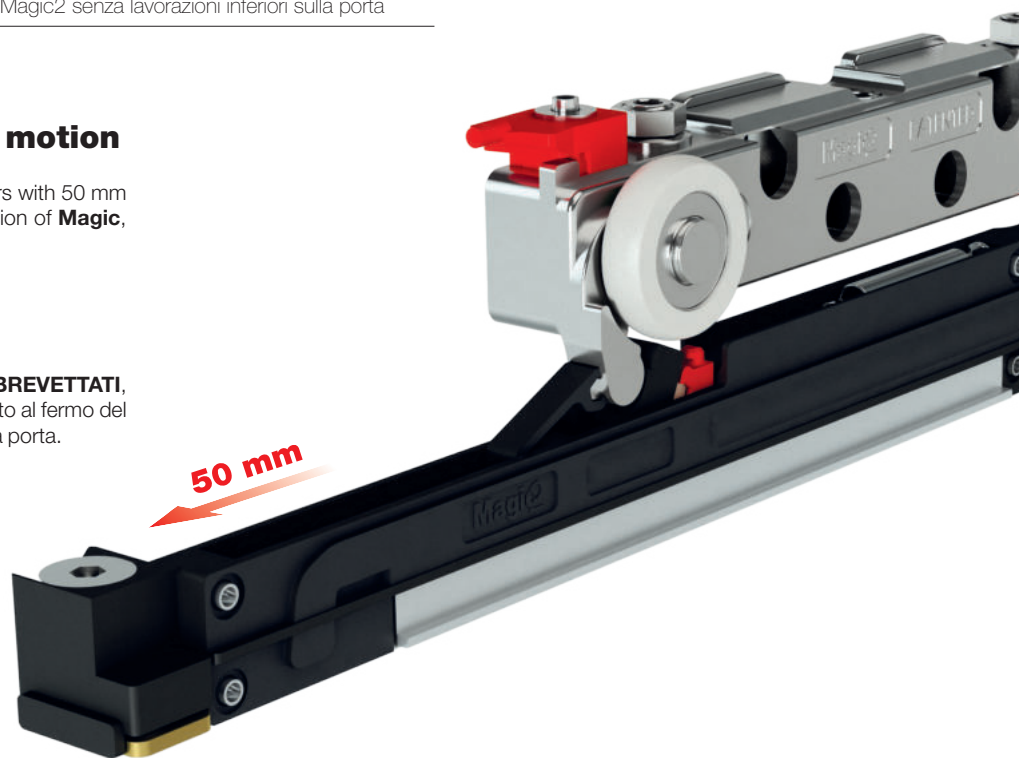

PATENTED

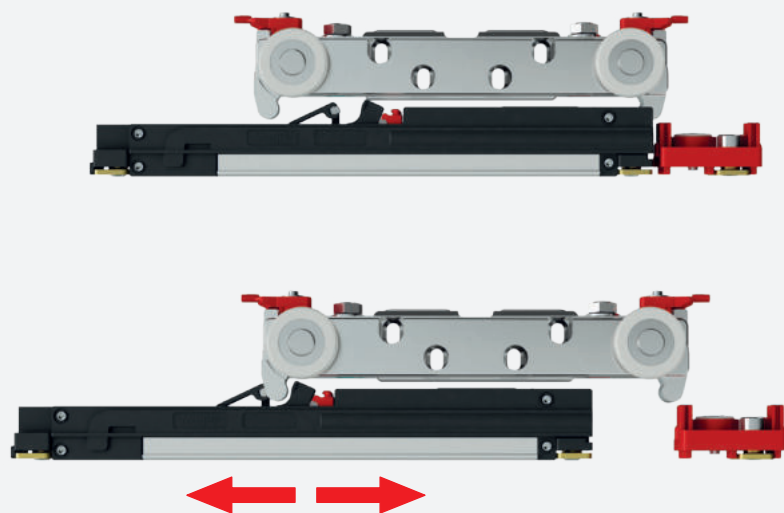

New dampers with adjustable positioning

New **Magic²** adjustable dampers were designed to be independent from wall-spacer wheels. New dampers are suitable to be moved into the track to allow door positioning adjustment.

Nuovi fermi con posizione regolabile

I nuovi fermi del **Magic²** sono stati progettati per essere indipendenti dal distanziale. All'occorrenza si possono spostare per regolare la posizione della porta.

New position of wall-spacer wheels

In **Magic²** system wall-spacer wheels are positioned on the door extremities. The wall-spacer wheels are so positioned in order to protect the door from wall contact, when wall surface are not plane.

Nuova posizione per le ruote distanziali

Nel sistema **Magic²** le ruote distanziali sono posizionate alle estremità della porta. Le ruote distanziali così posizionate proteggono la porta da contatti con la parete, in caso di muri con superfici irregolari.



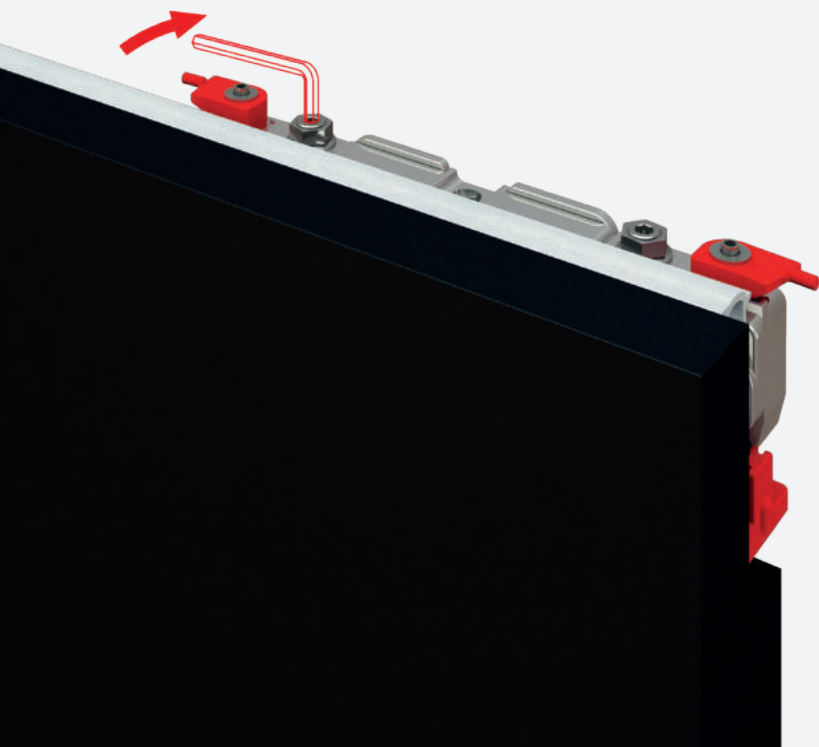

New patented adjustment system

New **Magic² PATENTED** sliding trolley integrates following door adjustments:

- Door height adjustment from floor
- Micrometric adjustment of door from wall
- Micrometric adjustment of door parallelism from wall

Door adjustments of wall distance and parallelism, are meant to compensate possible irregularities of wall. All adjustments are available in the top of sliding trolley, without removing the door.

Nuovo sistema brevettato di regolazione

Il nuovo scorrevole **Magic² BREVETTATO** integra le seguenti regolazioni:

- Regolazione dell'altezza della porta dal pavimento
- Regolazione micrometrica della distanza della porta dalla parete
- Regolazione micrometrica del parallelismo della porta rispetto alla parete

Le regolazioni di distanza e parallelismo della porta, si utilizzano per compensare eventuali irregolarità della parete. Tutte le regolazioni si realizzano dalla parte superiore dello scorrevole, senza sganciare la porta.

Practical anti-jumping system

Magic² sliding trolley includes two new turning anti-jumping activation elements. Turning anti-jumping activation elements are equipped with two safety levers, easy to rotate with no tools required. Safety levers, clearly visible, will have to be removed once anti-jumping system is activated in order to insert end caps.

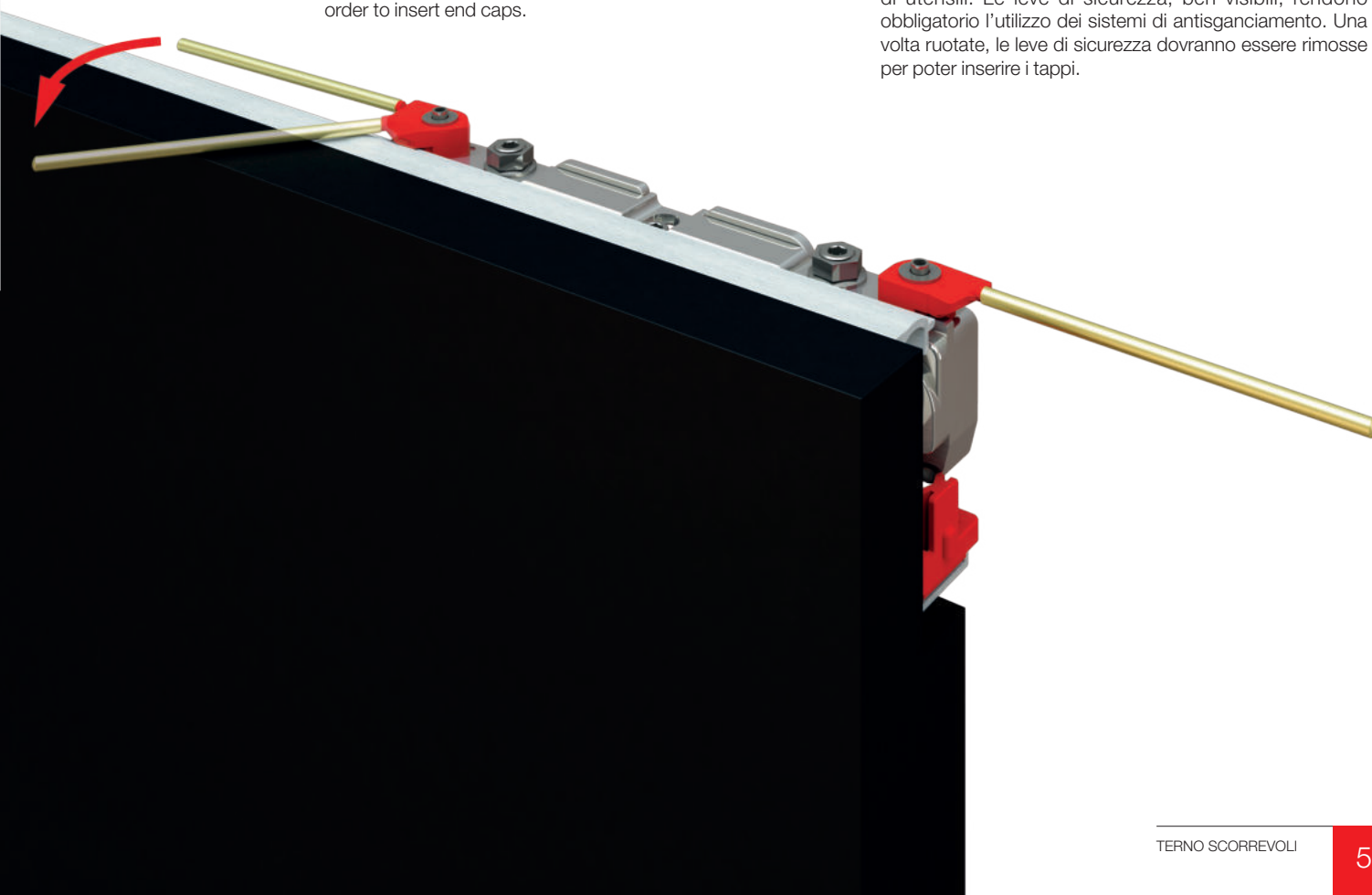

Pratico sistema di antisganciamento

Lo scorrevole **Magic²** comprende due nuovi elementi rotanti di antisganciamento. In questi nuovi elementi sono inserite due leve di sicurezza, per ruotarli senza l'utilizzo di utensili. Le leve di sicurezza, ben visibili, rendono obbligatorio l'utilizzo dei sistemi di antisganciamento. Una volta ruotate, le leve di sicurezza dovranno essere rimosse per poter inserire i tappi.

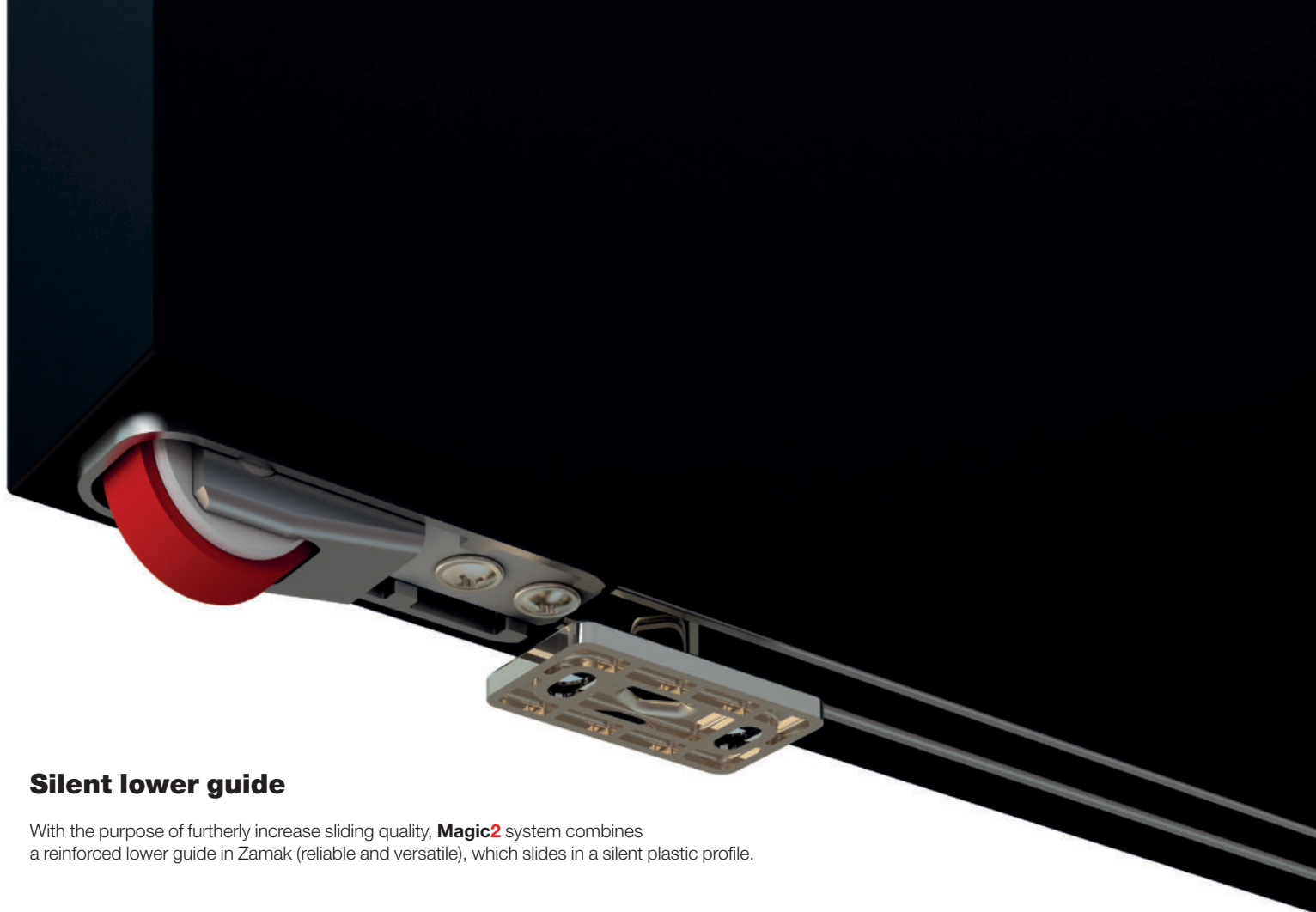

Silent lower guide

With the purpose of furtherly increase sliding quality, **Magic2** system combines a reinforced lower guide in Zamak (reliable and versatile), which slides in a silent plastic profile.

Guida inferiore silenziosa

Per migliorare ancor di più lo scorrimento, il sistema **Magic2** integra una guida inferiore rinforzata in zama (resistente e versatile), che scorre in un profilo in plastica molto silenzioso.

New patented bottom wheels designed for a better sliding

New **Magic2** bottom wheels are equipped with a **PATENTED** suspension spring system and were designed with a larger diameter, bigger bearing and steel pivots. Rubber surface have been enlarged as well, in order to reinforce wheels and improve sliding quality.

An additional important **PATENTED** innovation in lower sliding system is the introduction of two padded fixed springs which can grant damping function during door motion up to 40kg. Over 40kg of door weight and up to 80kg of maximum load capacity, new bottom wheels will be more flexible than previous version, with their Zamak surface to lean on a rubber internal cylinder, which act as a small shock absorber, granting more stability during sliding motion.

The **Magic2** wheels rubber have high performance:

- it does not leave any trace or sign on sliding surface like floors and walls
- it does not deform over time

Ruote inferiori brevettate per una migliore scorrevolezza

Le nuove ruote inferiori del sistema **Magic2** hanno molleggio **BREVETTATO**, e sono state progettate con diametro, cuscinetti e perni in acciaio maggiorati. Anche il rivestimento in gomma è stato raddoppiato per aumentare la forza e la scorrevolezza delle ruote.

Un'altra importante innovazione **BREVETTATA** nel sistema di scorrimento inferiore è l'inserimento di due molle fisse maggiorate che permettono di ammortizzare il movimento della porta fino ad una portata di 40 kg. Oltre i 40 kg, e fino ad un massimo di 80 kg, queste nuove ruote flettono maggiormente e la superficie realizzata in zama si appoggia su di un cilindro di gomma interno che funge da ammortizzatore supplementare garantendo maggior stabilità.

La gomma delle ruote di **Magic2** è altamente performante:

- non lascia traccia sulle superfici di scorrimento come pavimenti e pareti
- non si deforma nel tempo

KG 0 < KG 40

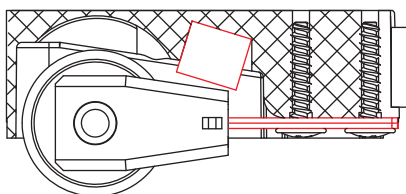

KG 40 < KG 80

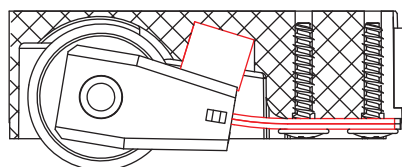

Built-in sliding track with not-through milling

Upper sliding track can be installed "built-in" into a blind milling. Laterally, track's end caps won't be visible, improving even more the aesthetics of door. Door installation and adjustment are not going to be different than usual, because available on the top of the door.

Binario incassato in fresata non passante

Il binario superiore può essere incassato in una fresata cieca. Lateralmente non saranno visibili i tappi del binario, migliorando ulteriormente l'estetica della porta. L'installazione e regolazione della porta non variano perché le regolazioni si effettuano dal lato superiore della porta.

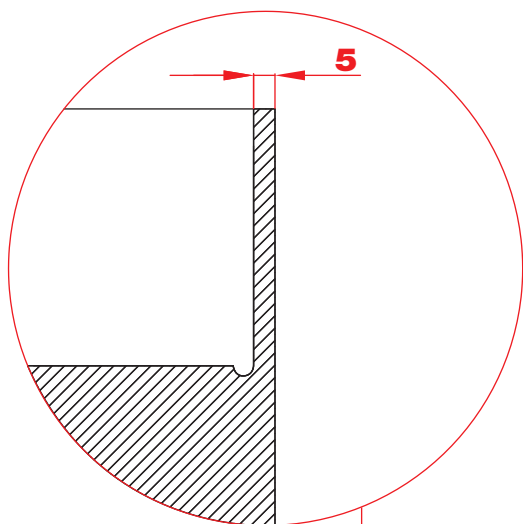

Magic² Mix Down

PATENTED

Magic² Mix Down integrates all innovative features of **Magic²** system, but it also allows to use the system with economical industrial laminated panels with fixed standard height. Thanks to **Magic² Mix Down** all additional milling processing on the lower side of the door have been eliminated. The track, indeed, is directly screwed on the bottom edge of the door. With **Magic² Mix Down** system is possible to realize standard doors with thickness from 38 to 44 mm.

Magic² Mix Down integra le caratteristiche innovative del sistema **Magic²**, ma si differenzia per la possibilità di utilizzare direttamente il sistema con pannelli economici in laminato industriale con altezza standard. Grazie a **Magic² Mix Down**, non occorrono lavorazioni di fresatura nella parte inferiore della porta: il binario, infatti, viene avvitato direttamente nella parte bassa della porta. Con il sistema **Magic² Mix Down** si possono utilizzare porte standard con spessori da 38 a 44 mm.





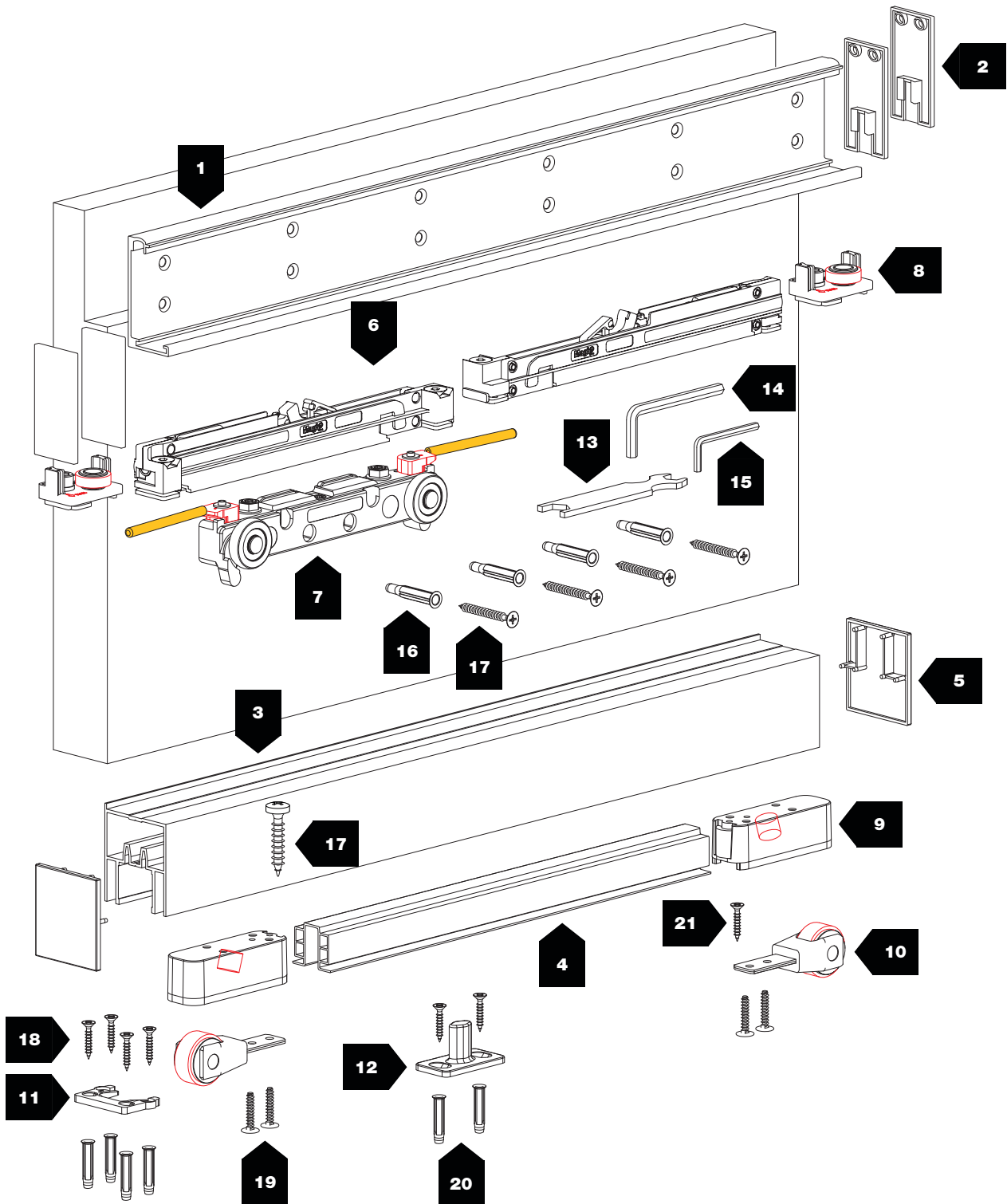





38 ÷ 44 mm











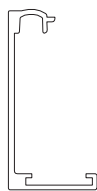
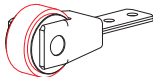

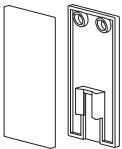
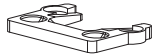
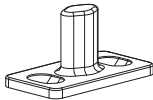
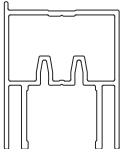
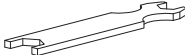
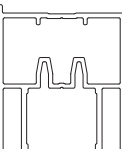
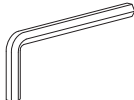
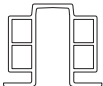

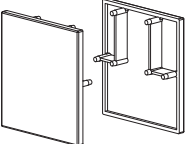

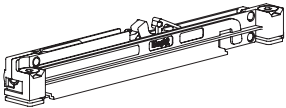
40 ÷ 80 kg



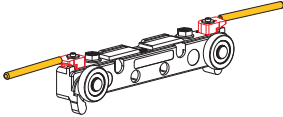

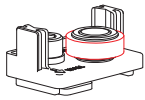
10 mm

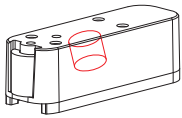
COLORS / COLORI

 Brushed Anodized Silver
Argento Spazzolato

 Brushed Anodized Black
Nero Spazzolato

| N° | Barcode | | kg | →← | N° | Barcode | | kg | →← |
|----|---------|---|-------|---|----|-------------|---|-------|---|
| 1 | 2850 |  | - | | 10 | 2857 |  | 40-80 |  |
| 2 | 2851/A |  | - | | 11 | 2859 |  | - | |
| | 2851/N | | | | 12 | 2855 |  | - | |
| 3 | 2888 |  | - | 38-40 mm | 13 | 1025 |  | - | |
| | 2890 |  | - | 42-44 mm | 14 | 538 |  | - | |
| 4 | 2860 |  | - | | 15 | 654 |  | - | |
| 5 | 2894 |  | - | 38-40 mm | 16 | FISCHER UX6 |  | - | |
| | 2892 | | - | 42-44 mm | 17 | 4,5x40 |  | - | |
| 6 | 2864-40 |  | 40 |  | 18 | 4x30 |  | - | |
| | 2864-80 | | 80 | | 19 | 4x20 |  | - | |
| 7 | 2852 |  | 40-80 |  | 20 | FISCHER SX5 |  | - | |
| 8 | 2856 |  | - |  | 21 | 3,9x13 |  | - | |
| 9 | 2858 |  | 40-80 |  | | | | | |

-  N.2 Soft damper stoppers
N.2 Fermi ammortizzati
-  Customizable door width
Larghezza porta personalizzabile
-  Patented system
Sistema brevettato

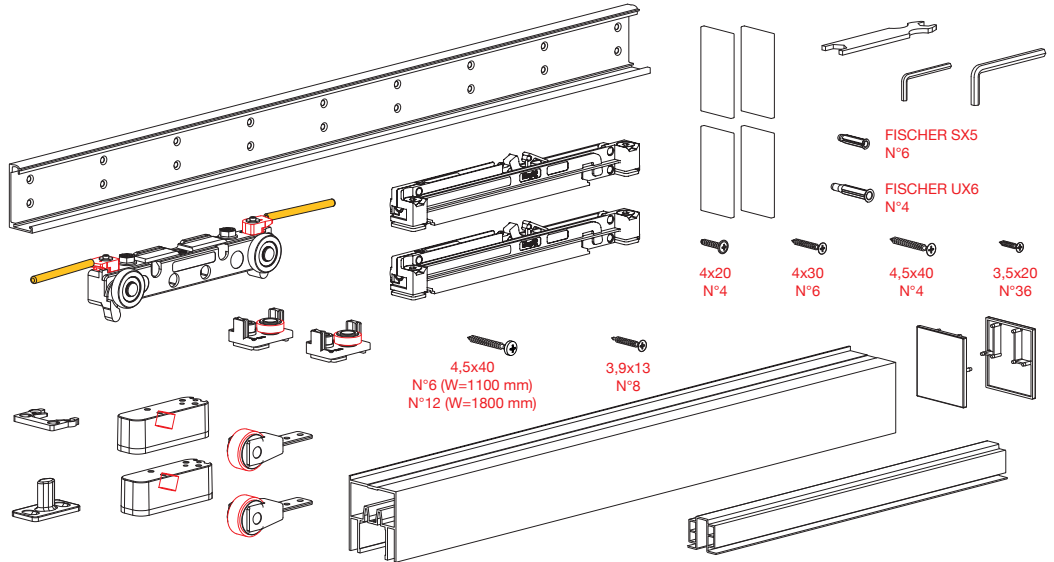

| CODE | COLOURS / COLORI | |  |  |  |  |
|-----------------------------------|------------------|-----|--|---|---|---|
| | AS | NS | | | | |
| K.0442.1 <input type="checkbox"/> | .02 | .15 | 40 kg | 38-40 mm | 1100 mm | 6x |
| K.0442.3 <input type="checkbox"/> | .02 | .15 | | 42-44 mm | | 6x |
| K.0442.2 <input type="checkbox"/> | .02 | .15 | | 38-40 mm | 1800 mm | 4x |
| K.0442.4 <input type="checkbox"/> | .02 | .15 | | 42-44 mm | | 4x |
| K.0444.1 <input type="checkbox"/> | .02 | .15 | 80 kg | 38-40 mm | 1100 mm | 6x |
| K.0444.3 <input type="checkbox"/> | .02 | .15 | | 42-44 mm | | 6x |
| K.0444.2 <input type="checkbox"/> | .02 | .15 | | 38-40 mm | 1800 mm | 4x |
| K.0444.4 <input type="checkbox"/> | .02 | .15 | | 42-44 mm | | 4x |

MEASUREMENTS DESCRIPTION / DESCRIZIONE MISURE

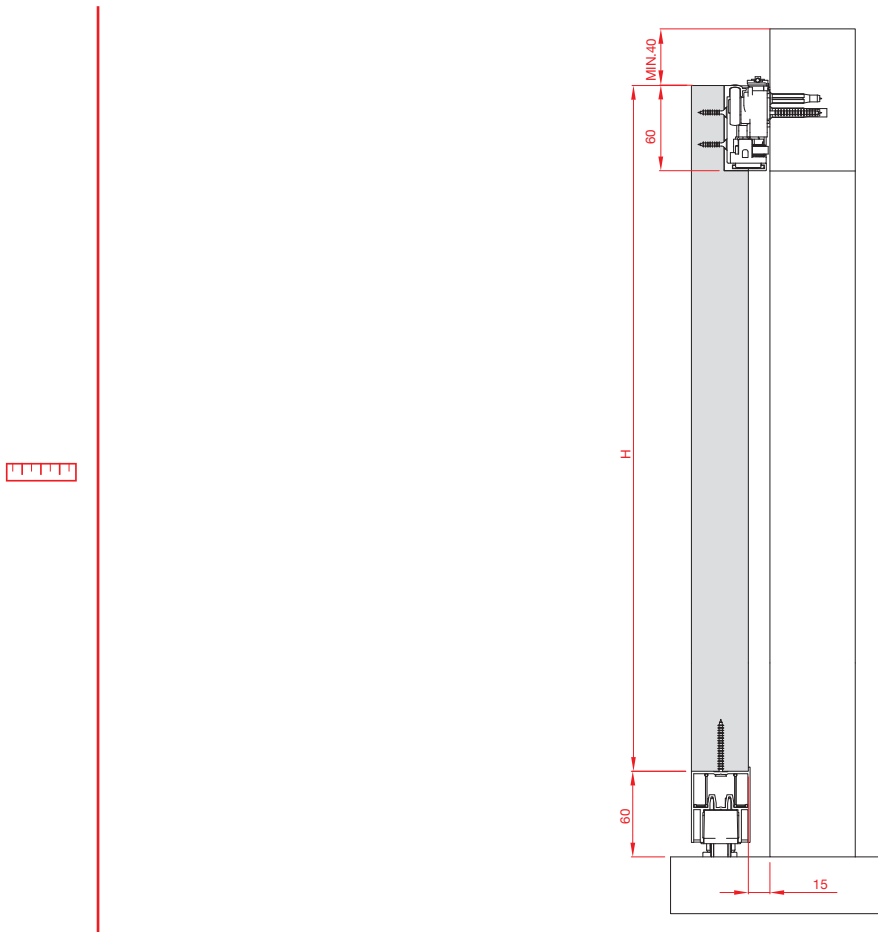

MILLING DESCRIPTION / DESCRIZIONE DELLE LAVORAZIONI

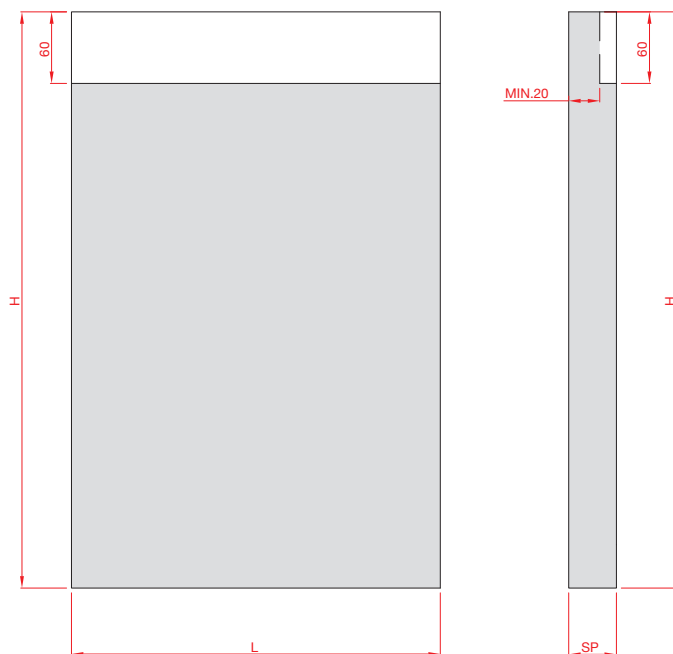

PROFILES CUTTING MEASUREMENTS / MISURE DI TAGLIO DEI PROFILI

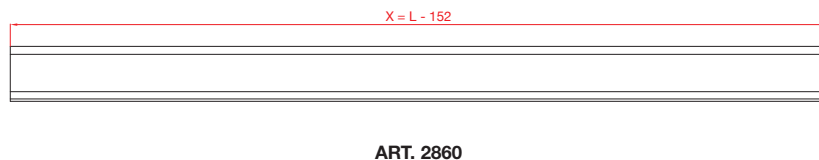
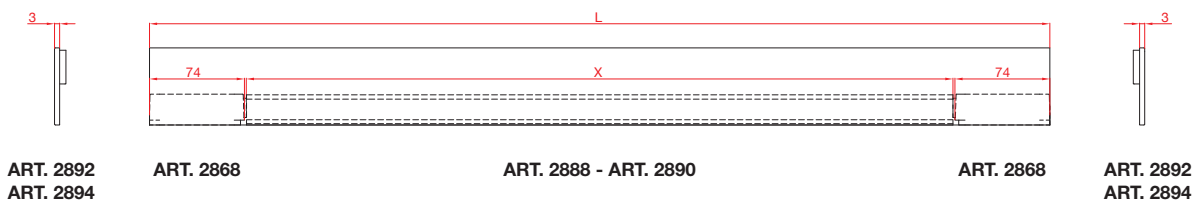
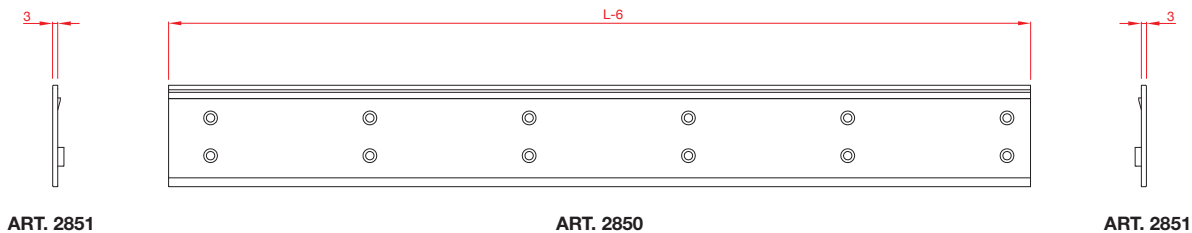
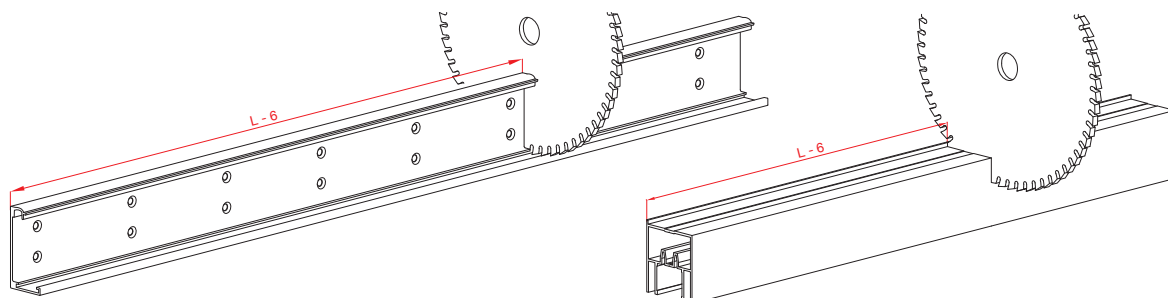

ACCESSORIES PLACEMENT (STANDARD POSITION) / POSIZIONAMENTO DEGLI ACCESSORI (POSIZIONE STANDARD)

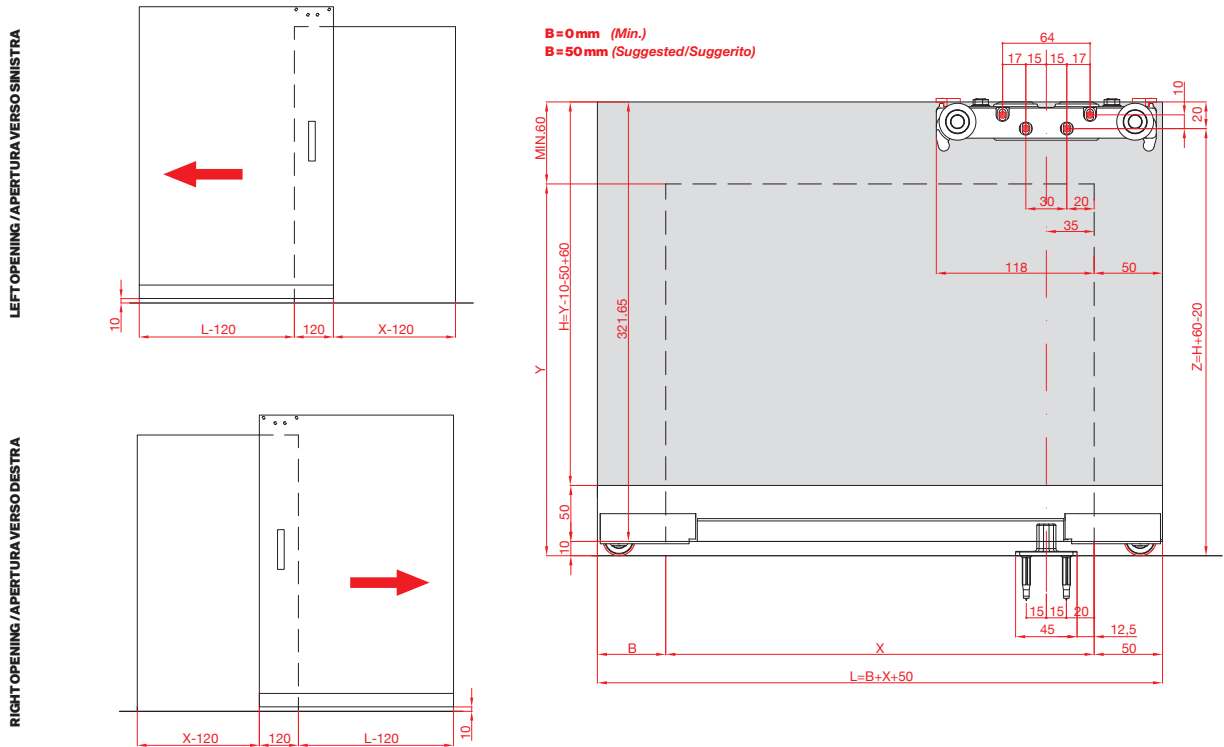

K.0442.1... - K.0442.3... - K.0444.1... - K.0444.3...

B=0
X= MIN. 800 (L=850)
X= MAX. 1050 (L=1100)

B=50
X= MIN. 800 (L=900)
X= MAX. 1000 (L=1100)

K.0442.2... - K.0442.4... - K.0444.2... - K.0444.4...

B=0
X= MIN. 800 (L=850)
X= MAX. 1750 (L=1800)

B=50
X= MIN. 800 (L=900)
X= MAX. 1700 (L=1800)

ACCESSORIES PLACEMENT (INTERMEDIATE POSITION) / POSIZIONAMENTO DEGLI ACCESSORI (POSIZIONE INTERMEDIA)

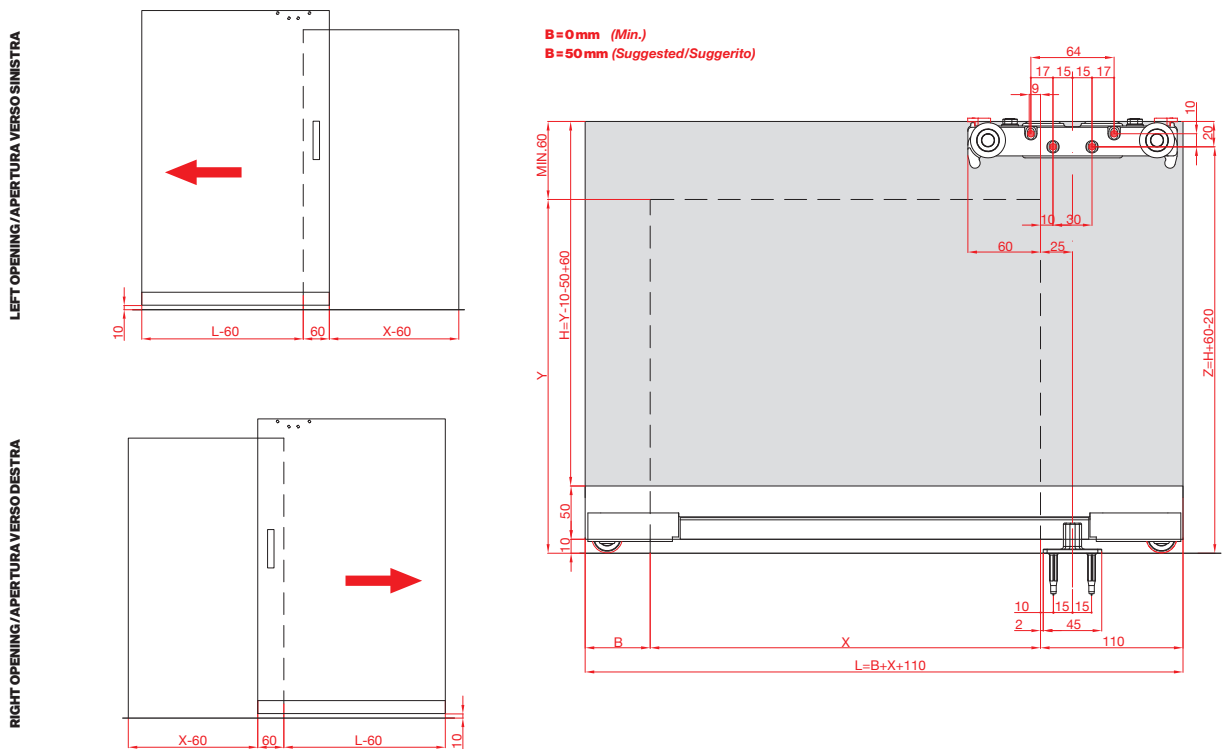

K.0442.1... - K.0442.3... - K.0444.1... - K.0444.3...

B=0
X= MIN. 740 (L=850)
X= MAX. 990 (L=1100)

B=50
X= MIN. 740 (L=900)
X= MAX. 940 (L=1100)

K.0442.2... - K.0442.4... - K.0444.2... - K.0444.4...

B=0
X= MIN. 740 (L=850)
X= MAX. 1690 (L=1800)

B=50
X= MIN. 740 (L=900)
X= MAX. 1640 (L=1800)

ACCESSORIES PLACEMENT (TOTAL OPENING POSITION) / POSIZIONAMENTO DEGLI ACCESSORI (POSIZIONE APERTURA TOTALE)

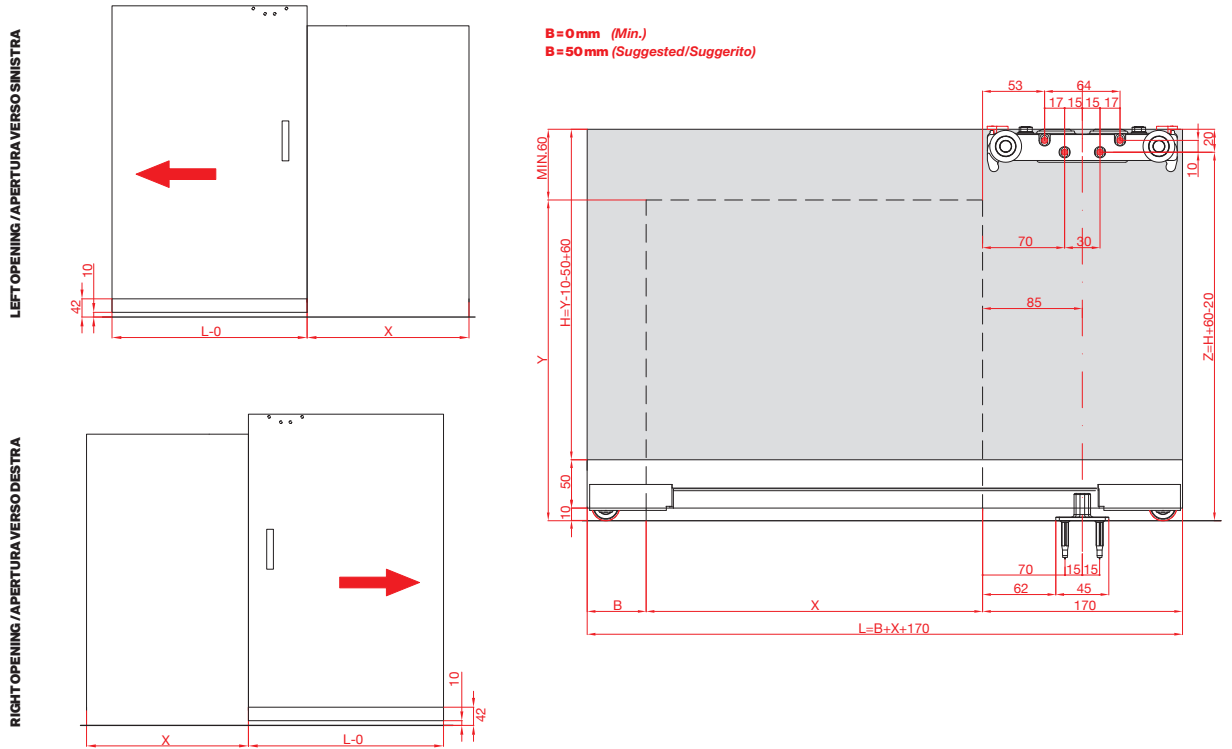

B=0mm (Min.)
B=50mm (Suggested/Suggerito)

K.0442.1... - K.0442.3... - K.0444.1... - K.0444.3...

B=0
X= MIN. 680 (L=850)
X= MAX. 930 (L=1100)

B=50
X= MIN. 680 (L=900)
X= MAX. 880 (L=1100)

K.0442.2... - K.0442.4... - K.0444.2... - K.0444.4...

B=0
X= MIN. 680 (L=850)
X= MAX. 1630 (L=1800)

B=50
X= MIN. 680 (L=900)
X= MAX. 1580 (L=1800)

ART. 2859 - END STOPPER / FINE CORSA

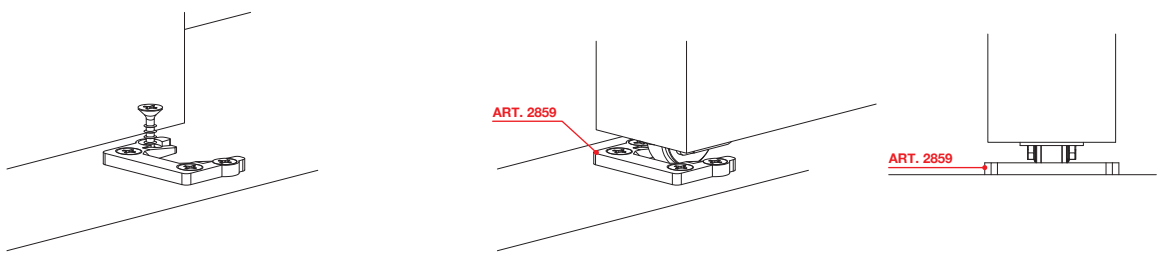

**ALUMINIUM TRACK FOR IRREGULAR FLOOR
 PROFILO IN ALLUMINIO PER PAVIMENTAZIONE IRREGOLARE**

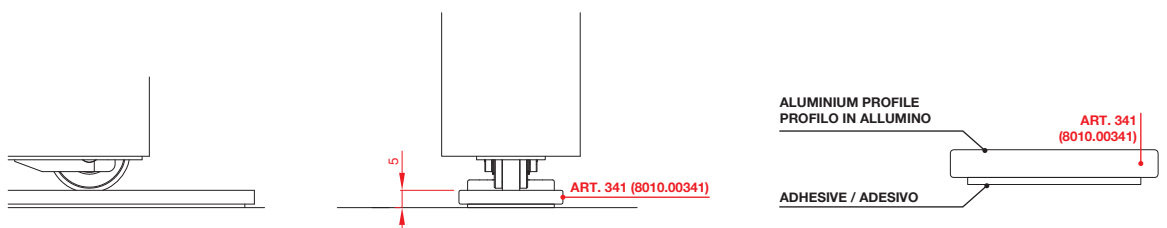

ART. 341
8 01 0 .00341



Magic² Mix Up

The original invisible sliding doors system
Il sistema invisibile originale per porte scorrevoli



Tracks / Binari

ALUMINUM FINISHES CODES / CODICI FINITURE ALLUMINIO

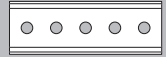

8 ... 0.0

| | | |
|---|---|---|
| 01 • (Anodized Silver / Argento - A) | 13 • (Brushed Anodized Dark Brown / E3 Spazzolato - E3S) | 17 • (Brushed Anodized Nickel / Nichel Spazzolato - NKS) |
| 02 • (Brushed Anodized Silver / Argento Spazzolato - AS) | 14 • (Anodized Black / Nero - N) | 25 • (Brushed Anodized Graphite / Grafite Spazzolato - GRFS) |
| 12 • (Anodized Dark Brown / E3 - E3) | 15 • (Brushed Anodized Black / Nero Spazzolato - NS) | 26 • (Anodized Graphite / Grafite - GRF) |

01 - 02 STANDARD / 12 - 13 - 14 - 15 - 17 - 25 - 26 SPECIAL

Magic2

COMPLETE BOX KIT / KIT COMPLETO IN SCATOLA



K Complete kit / Kit completo

| | | | | | | | | | |
|--|--|-------------|--|---------------------------------|----------|--|---------|-----------|-------------------------------------|
| | | | | | | | | | |
| | | 0031 | | Magic2 - Wood Magic2 - Legno | | | | | |
| | | | | | | | | | |
| | | | | | 1 | | 1100 mm | | |
| | | | | | 2 | | 1800 mm | | |
| | | | | | | | | | |
| | | | | | | | | 01 | Standard Finish / Finitura Standard |

Magic2 Frame

COMPLETE BOX KIT / KIT COMPLETO IN SCATOLA



K Complete kit / Kit completo

| | | | | | | | | | |
|--|--|-------------|--|-----------------------|----------|--|--|-----------|--|
| | | | | | | | | | |
| | | 0461 | | 1500 mm - 80kg | | | | | |
| | | 0462 | | 1100 mm - 80kg | | | | | |
| | | | | | | | | | |
| | | | | | 1 | | N.2 Soft damper stoppers N.2 Fermi ammortizzati | | |
| | | | | | | | | | |
| | | | | | 1 | | 2200 mm | | |
| | | | | | 2 | | 2600 mm | | |
| | | | | | 3 | | 3000 mm | | |
| | | | | | | | | | |
| | | | | | | | | 02 | Brushed Anodized Silver / Argento Spazzolato |
| | | | | | | | | 13 | Brushed Anodized Dark Brown / E3 Spazzolato |
| | | | | | | | | 15 | Brushed Anodized Black / Nero Spazzolato |
| | | | | | | | | 17 | Brushed Anodized Nickel / Nichel Spazzolato |
| | | | | | | | | 25 | Brushed Anodized Graphite / Grafite Spazzolato |

Magic2 Vetro

COMPLETE BOX KIT / KIT COMPLETO IN SCATOLA















K Complete kit / Kit completo

| | | | | | | | | | |
|--|--|-------------|--|-----------------------|----------|--|-------------------------------------|-----------|--|
| | | | | | | | | | |
| | | 0041 | | 1100 mm - 80kg | | | | | |
| | | 0042 | | 1800 mm - 80kg | | | | | |
| | | | | | | | | | |
| | | | | | 1 | | Glass thk. / Vetri sp. 8 mm (5/16") | | |
| | | | | | 2 | | Glass thk. / Vetri sp. 10 mm (3/8") | | |
| | | | | | 3 | | Glass thk. / Vetri sp. 12 mm (1/2") | | |
| | | | | | | | | | |
| | | | | | | | | 02 | Brushed Anodized Silver / Argento Spazzolato |

Magic2 Mix

COMPLETE BOX KIT / KIT COMPLETO IN SCATOLA









| | | |
|----------|-----------------------------|--|
| K | Complete kit / Kit completo | |
| | . | |
| | 0441 |  Magic2 MIX UP |
| | 0442 |  Magic2 MIX DOWN |
| | 0443 |  Magic2 MIX UP |
| | 0444 |  Magic2 MIX DOWN |
| | . | |
| | 1 |  1100 mm →  38-40 mm |
| | 2 |  1800 mm →  38-40 mm |
| | 3 |  1100 mm →  42-44 mm |
| | 4 |  1800 mm →  42-44 mm |
| | . | |
| | 02 | Brushed Anodized Silver / Argento Spazzolato |
| | 15 | Brushed Anodized Black / Nero Spazzolato |

Magic2 Uni

COMPLETE BOX KIT / KIT COMPLETO IN SCATOLA



| | | |
|----------|-----------------------------|--|
| K | Complete kit / Kit completo | |
| | . | |
| | 0451 |  40 mm - 30 kg |
| | 0452 |  44 mm - 30 kg |
| | 0453 |  40 mm - 80 kg |
| | 0454 |  44 mm - 80 kg |
| | . | |
| | 1 |  1100 mm |
| | 2 |  1800 mm |
| | . | |
| | 02 | Brushed Anodized Silver / Argento Spazzolato |
| | 15 | Brushed Anodized Black / Nero Spazzolato |

EXAMPLE / ESEMPIO

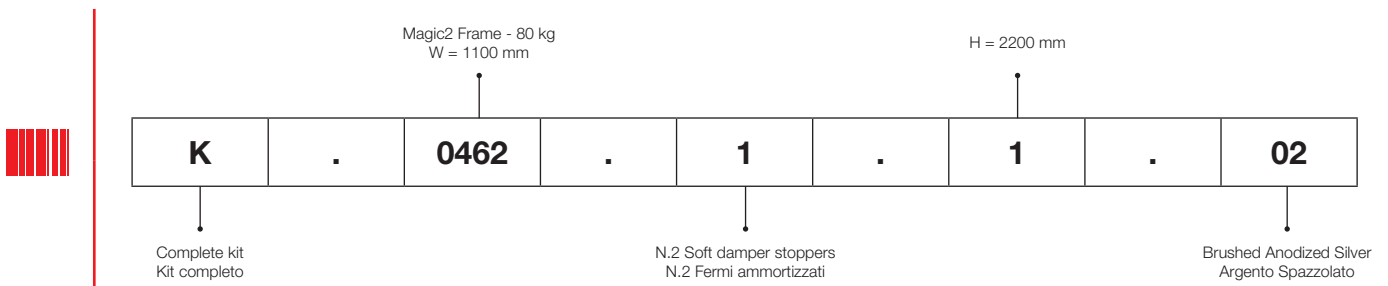

More than 50mm of damping motion

Magic² system integrates new **PATENTED** dampers with 50 mm of braking motion, 20 mm longer than previous version of **Magic**, while keeping the same door dimensions.

Oltre 50 mm di frenatura

Il sistema **Magic²** integra nuovi fermi ammortizzati **BREVETTATI**, per una frenatura di oltre 50 mm, più di 20 mm rispetto al fermo del modello **Magic**, mantenendo gli stessi ingombri della porta.

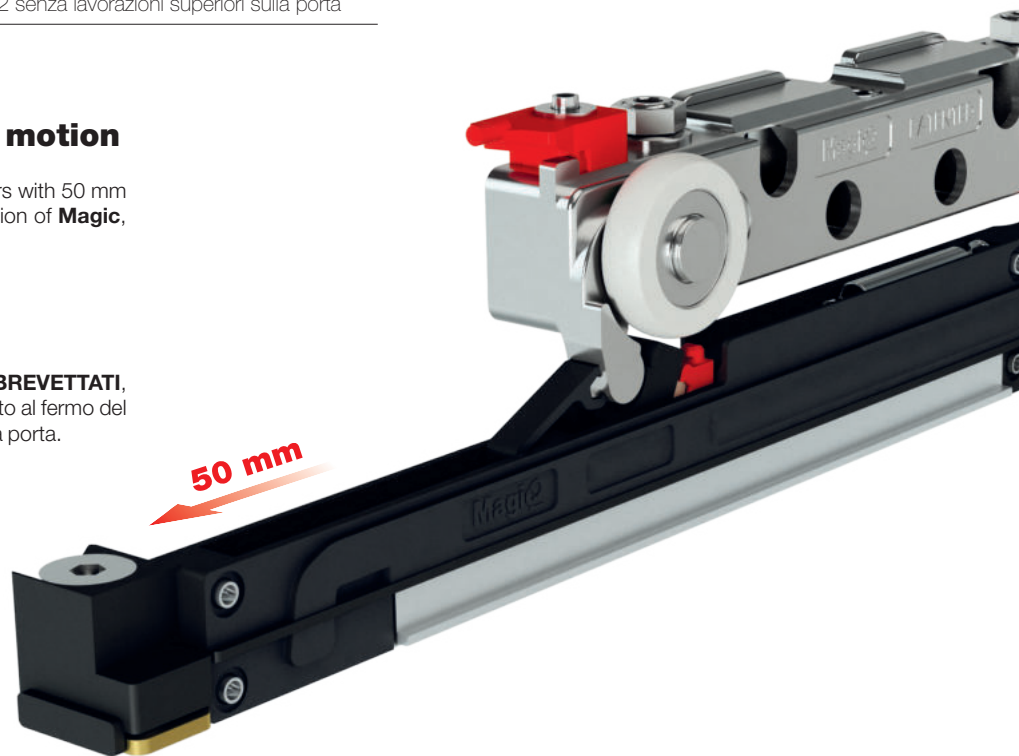

PATENTED

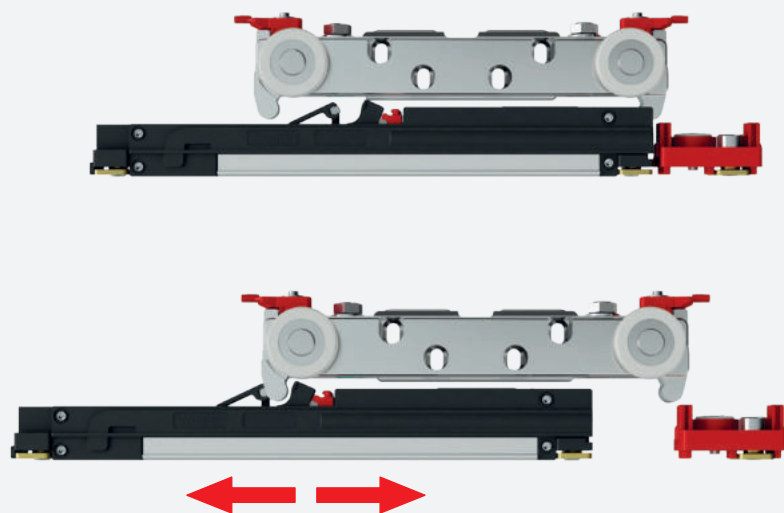

New dampers with adjustable positioning

New **Magic²** adjustable dampers were designed to be independent from wall-spacer wheels. New dampers are suitable to be moved into the track to allow door positioning adjustment.

Nuovi fermi con posizione regolabile

I nuovi fermi del **Magic²** sono stati progettati per essere indipendenti dal distanziale. All'occorrenza si possono spostare per regolare la posizione della porta.

New position of wall-spacer wheels

In **Magic²** system wall-spacer wheels are positioned on the door extremities. The wall-spacer wheels are so positioned in order to protect the door from wall contact, when wall surface are not plane.

Nuova posizione per le ruote distanziali

Nel sistema **Magic²** le ruote distanziali sono posizionate alle estremità della porta. Le ruote distanziali così posizionate proteggono la porta da contatti con la parete, in caso di muri con superfici irregolari.



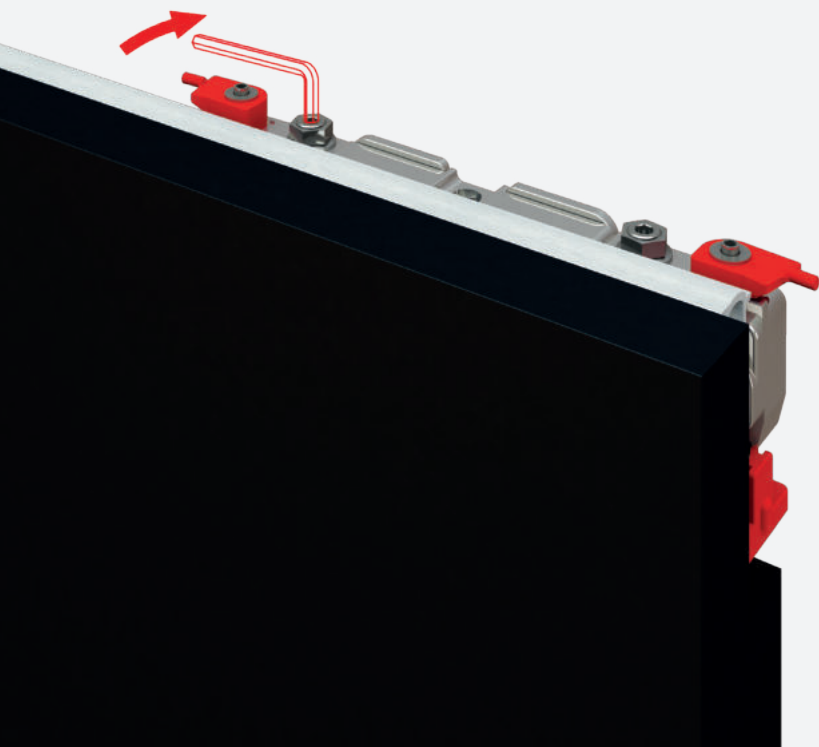

New patented adjustment system

New **Magic² PATENTED** sliding trolley integrates following door adjustments:

- Door height adjustment from floor
- Micrometric adjustment of door from wall
- Micrometric adjustment of door parallelism from wall

Door adjustments of wall distance and parallelism, are meant to compensate possible irregularities of wall. All adjustments are available in the top of sliding trolley, without removing the door.

Nuovo sistema brevettato di regolazione

Il nuovo scorrevole **Magic² BREVETTATO** integra le seguenti regolazioni:

- Regolazione dell'altezza della porta dal pavimento
- Regolazione micrometrica della distanza della porta dalla parete
- Regolazione micrometrica del parallelismo della porta rispetto alla parete

Le regolazioni di distanza e parallelismo della porta, si utilizzano per compensare eventuali irregolarità della parete. Tutte le regolazioni si realizzano dalla parte superiore dello scorrevole, senza sganciare la porta.

Practical anti-jumping system

Magic² sliding trolley includes two new turning anti-jumping activation elements. Turning anti-jumping activation elements are equipped with two safety levers, easy to rotate with no tools required. Safety levers, clearly visible, will have to be removed once anti-jumping system is activated in order to insert end caps.

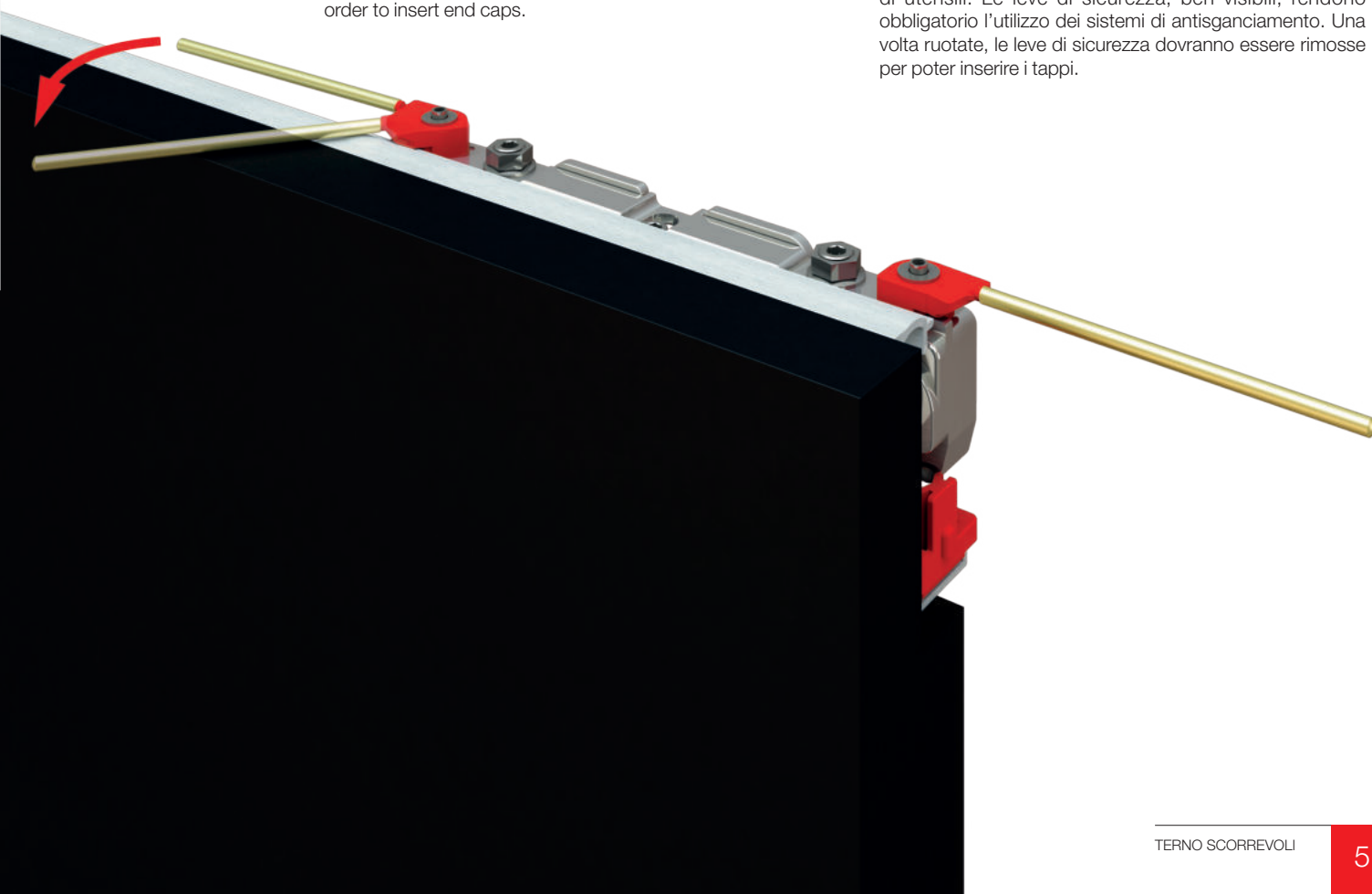

Pratico sistema di antisganciamento

Lo scorrevole **Magic²** comprende due nuovi elementi rotanti di antisganciamento. In questi nuovi elementi sono inserite due leve di sicurezza, per ruotarli senza l'utilizzo di utensili. Le leve di sicurezza, ben visibili, rendono obbligatorio l'utilizzo dei sistemi di antisganciamento. Una volta ruotate, le leve di sicurezza dovranno essere rimosse per poter inserire i tappi.

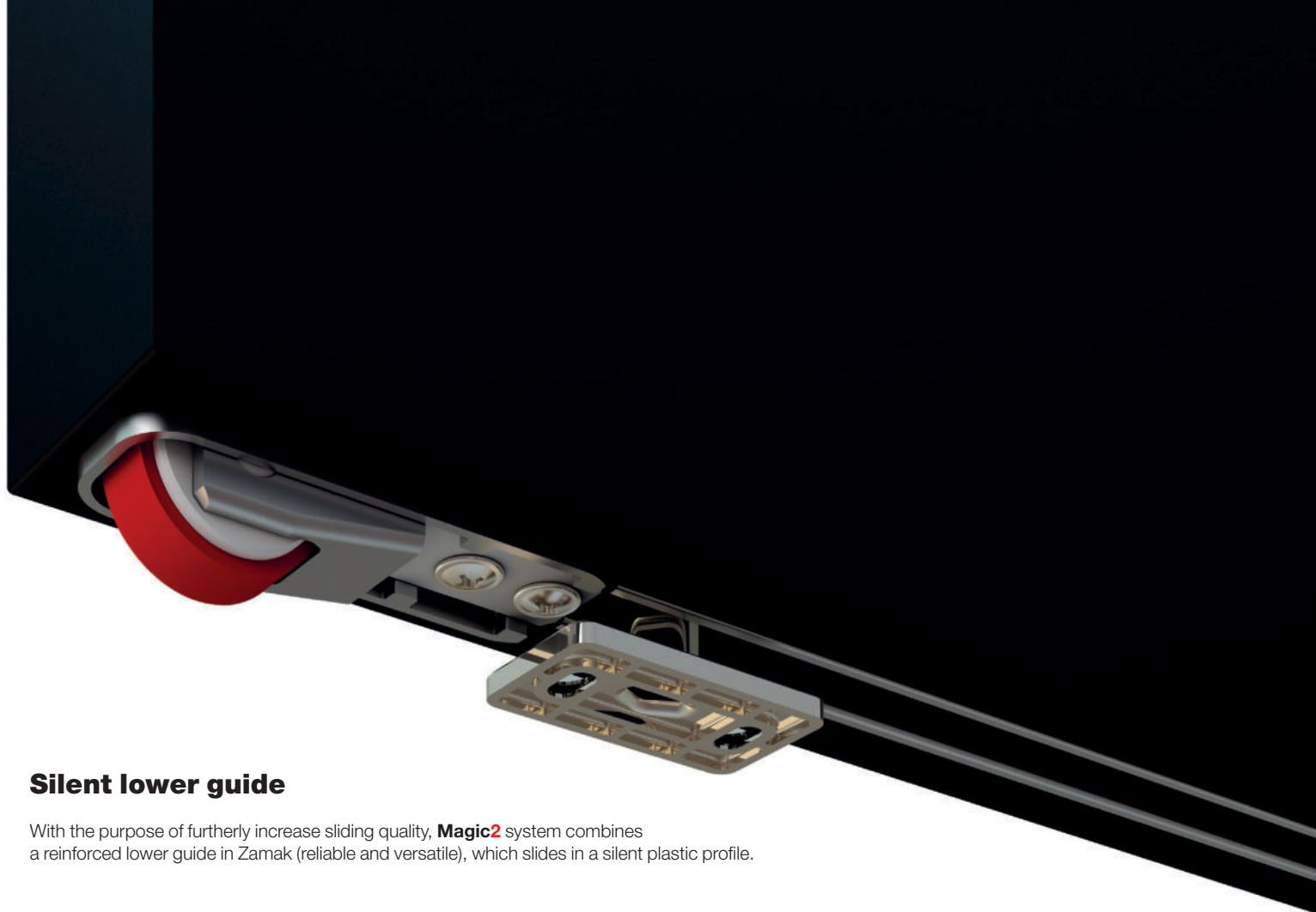

Silent lower guide

With the purpose of furtherly increase sliding quality, **Magic2** system combines a reinforced lower guide in Zamak (reliable and versatile), which slides in a silent plastic profile.

Guida inferiore silenziosa

Per migliorare ancor di più lo scorrimento, il sistema **Magic2** integra una guida inferiore rinforzata in zama (resistente e versatile), che scorre in un profilo in plastica molto silenzioso.

New patented bottom wheels designed for a better sliding

New **Magic2** bottom wheels are equipped with a **PATENTED** suspension spring system and were designed with a larger diameter, bigger bearing and steel pivots. Rubber surface have been enlarged as well, in order to reinforce wheels and improve sliding quality.

An additional important **PATENTED** innovation in lower sliding system is the introduction of two padded fixed springs which can grant damping function during door motion up to 40kg. Over 40kg of door weight and up to 80kg of maximum load capacity, new bottom wheels will be more flexible than previous version, with their Zamak surface to lean on a rubber internal cylinder, which act as a small shock absorber, granting more stability during sliding motion.

The **Magic2** wheels rubber have high performance:

- it does not leave any trace or sign on sliding surface like floors and walls
- it does not deform over time

Ruote inferiori brevettate per una migliore scorrevolezza

Le nuove ruote inferiori del sistema **Magic2** hanno molleggio **BREVETTATO**, e sono state progettate con diametro, cuscinetti e perni in acciaio maggiorati. Anche il rivestimento in gomma è stato raddoppiato per aumentare la forza e la scorrevolezza delle ruote.

Un'altra importante innovazione **BREVETTATA** nel sistema di scorrimento inferiore è l'inserimento di due molle fisse maggiorate che permettono di ammortizzare il movimento della porta fino ad una portata di 40 kg. Oltre i 40 kg, e fino ad un massimo di 80 kg, queste nuove ruote flettono maggiormente e la superficie realizzata in zama si appoggia su di un cilindro di gomma interno che funge da ammortizzatore supplementare garantendo maggior stabilità.

La gomma delle ruote di **Magic2** è altamente performante:

- non lascia traccia sulle superfici di scorrimento come pavimenti e pareti
- non si deforma nel tempo

KG 0 < KG 40

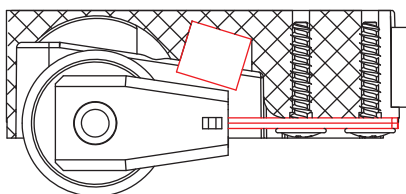

KG 40 < KG 80

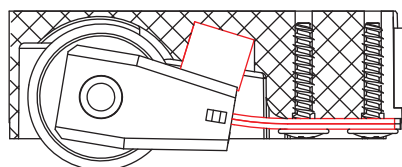

Built-in sliding track with not-through milling

Upper sliding track can be installed "built-in" into a blind milling. Laterally, track's end caps won't be visible, improving even more the aesthetics of door. Door installation and adjustment are not going to be different than usual, because available on the top of the door.

Binario incassato in fresata non passante

Il binario superiore può essere incassato in una fresata cieca. Lateralmente non saranno visibili i tappi del binario, migliorando ulteriormente l'estetica della porta. L'installazione e regolazione della porta non variano perché le regolazioni si effettuano dal lato superiore della porta.

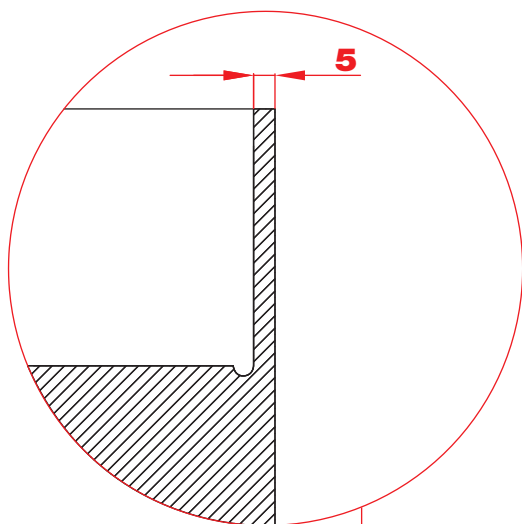

Magic² Mix Up

PATENTED

Magic² Mix Up integrates all innovative features of **Magic²** system, but it also allows to use the system with economical industrial laminated panels with fixed standard height. Thanks to **Magic² Mix Up** all additional milling processing on the upper side of the door have been eliminated. The track, indeed, is directly screwed on the top edge of the door. With **Magic² Mix Up** system is possible to realize standard doors with thickness from 38 to 44 mm.

Magic² Mix Up integra tutte le caratteristiche innovative del sistema **Magic²**, ma si differenzia per la possibilità di utilizzare il sistema con pannelli economici in laminato industriale con altezza standard. Grazie a **Magic² Mix Up**, vengono eliminate le lavorazioni di fresatura sulla porta: il binario, infatti, viene avvitato direttamente nella parte superiore della porta. Con il sistema **Magic² Mix Up** si possono utilizzare porte standard con spessori da 38 a 44 mm.





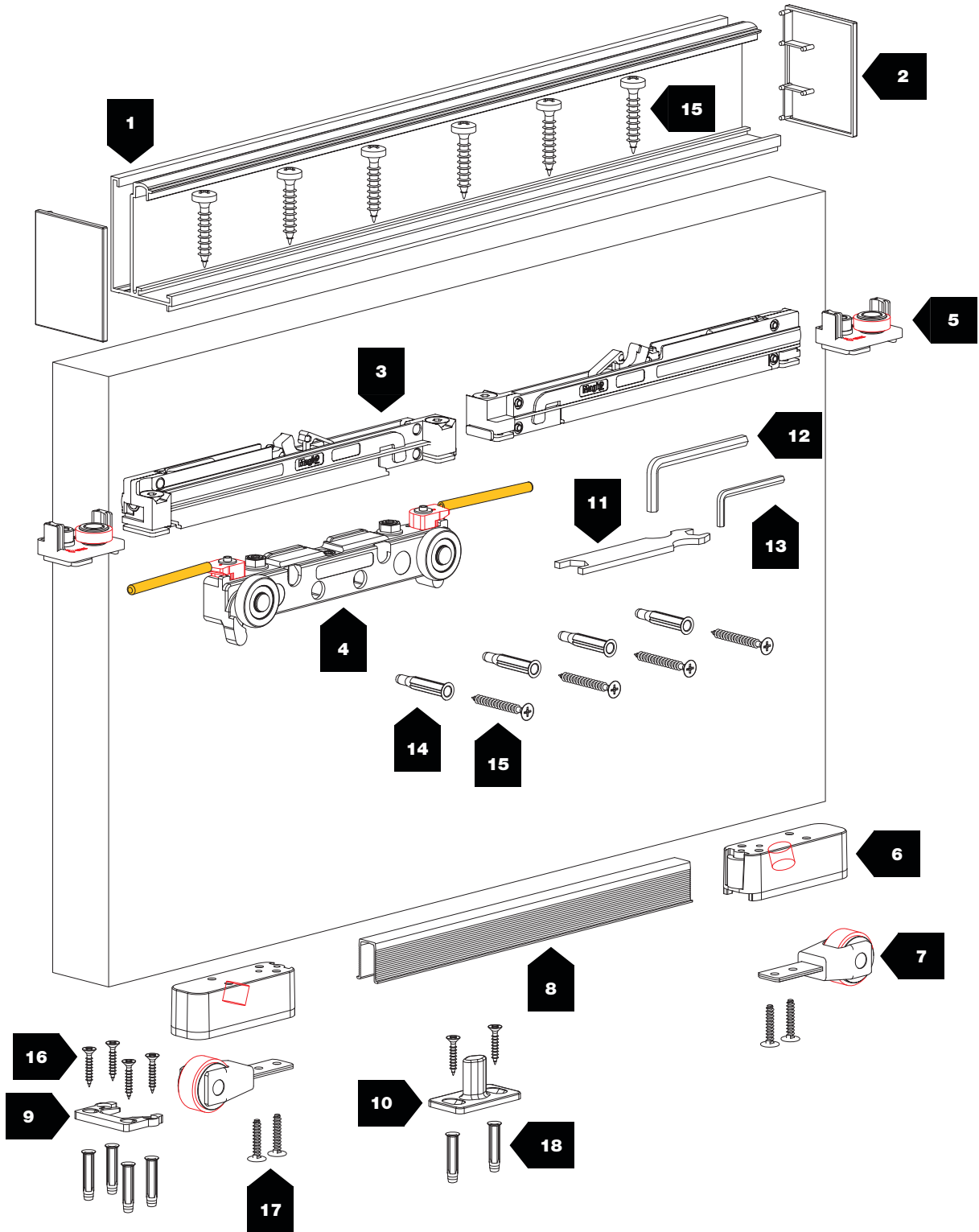





38 ÷ 44 mm











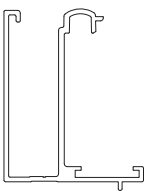
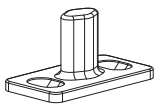
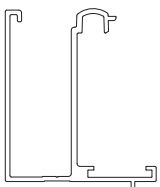

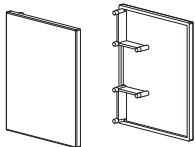
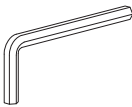
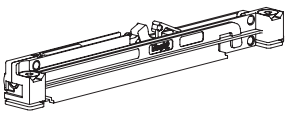

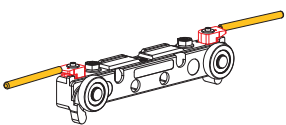

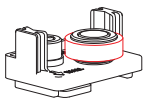
40 ÷ 80 kg

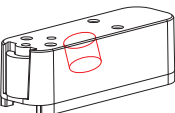

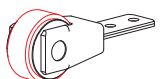
10 mm

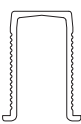
COLORS / COLORI

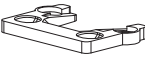
 Brushed Anodized Silver
Argento Spazzolato

 Brushed Anodized Black
Nero Spazzolato

| N° | Barcode | Image | kg | Dimensions | N° | Barcode | Image | kg | Dimensions |
|----|---------|---|-------|---|----|-------------|---|----|------------|
| 1 | 2870 |  | - | 38-40 mm | 10 | 2855 |  | - | |
| | 2880 |  | - | 42-44 mm | 11 | 1025 |  | - | |
| 2 | 2898 |  | - | 38-40 mm | 12 | 538 |  | - | |
| | 2896 | | - | 42-44 mm | | | | | |
| 3 | 2864-40 |  | 40 |  | 13 | 654 |  | - | |
| | 2864-80 | | 80 | | | | | | |
| 4 | 2852 |  | 40-80 |  | 14 | FISCHER UX6 |  | - | |
| 5 | 2856 |  | - |  | 15 | 4,5x40 |  | - | |
| 6 | 2858 |  | 40-80 |  | 16 | 4x30 |  | - | |
| 7 | 2857 |  | 40-80 |  | 17 | 4x20 |  | - | |
| 8 | 121 |  | - | | 18 | FISCHER SX5 |  | - | |
| 9 | 2859 |  | - | | | | | | |

-  N.2 Soft damper stoppers
N.2 Fermi ammortizzati
-  Customizable door width
Larghezza porta personalizzabile
-  Patented system
Sistema brevettato

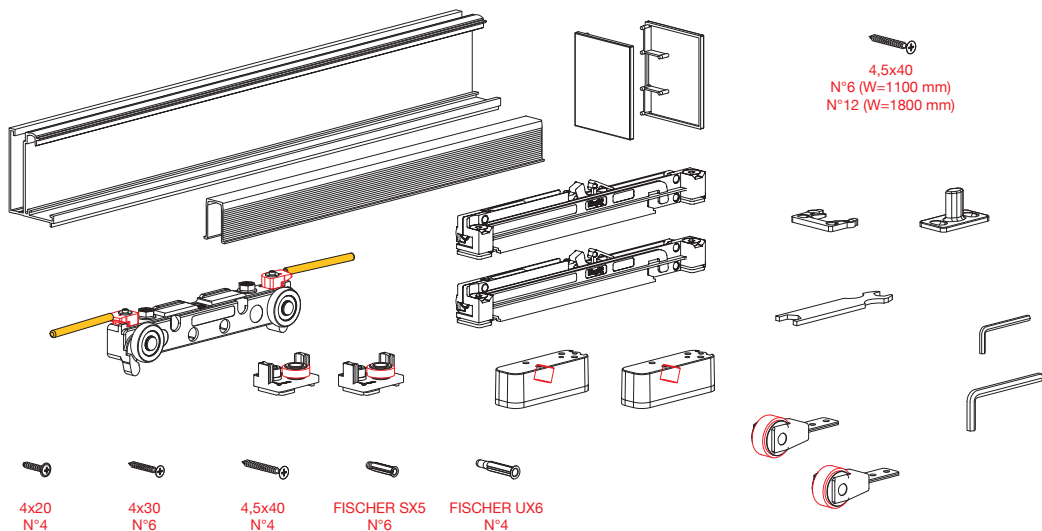

| CODE | COLOURS / COLORI | | AS | NS | MIN | MAX | MIN | |
|-----------------------------------|------------------|-----|-------|----------|----------|---------|-----|----------|
| | AS | NS | | | | | | |
| K.0441.1 <input type="checkbox"/> | .02 | .15 | 40 kg | 38-40 mm | 1100 mm | 6x | | |
| K.0441.3 <input type="checkbox"/> | .02 | .15 | | | | | | 42-44 mm |
| K.0441.2 <input type="checkbox"/> | .02 | .15 | | | 38-40 mm | 1800 mm | | 4x |
| K.0441.4 <input type="checkbox"/> | .02 | .15 | | | 42-44 mm | | | 4x |
| K.0443.1 <input type="checkbox"/> | .02 | .15 | 80 kg | 38-40 mm | 1100 mm | 6x | | |
| K.0443.3 <input type="checkbox"/> | .02 | .15 | | | | | | 42-44 mm |
| K.0443.2 <input type="checkbox"/> | .02 | .15 | | 38-40 mm | 1800 mm | 4x | | |
| K.0443.4 <input type="checkbox"/> | .02 | .15 | | 42-44 mm | | 4x | | |

MEASUREMENTS DESCRIPTION / DESCRIZIONE MISURE

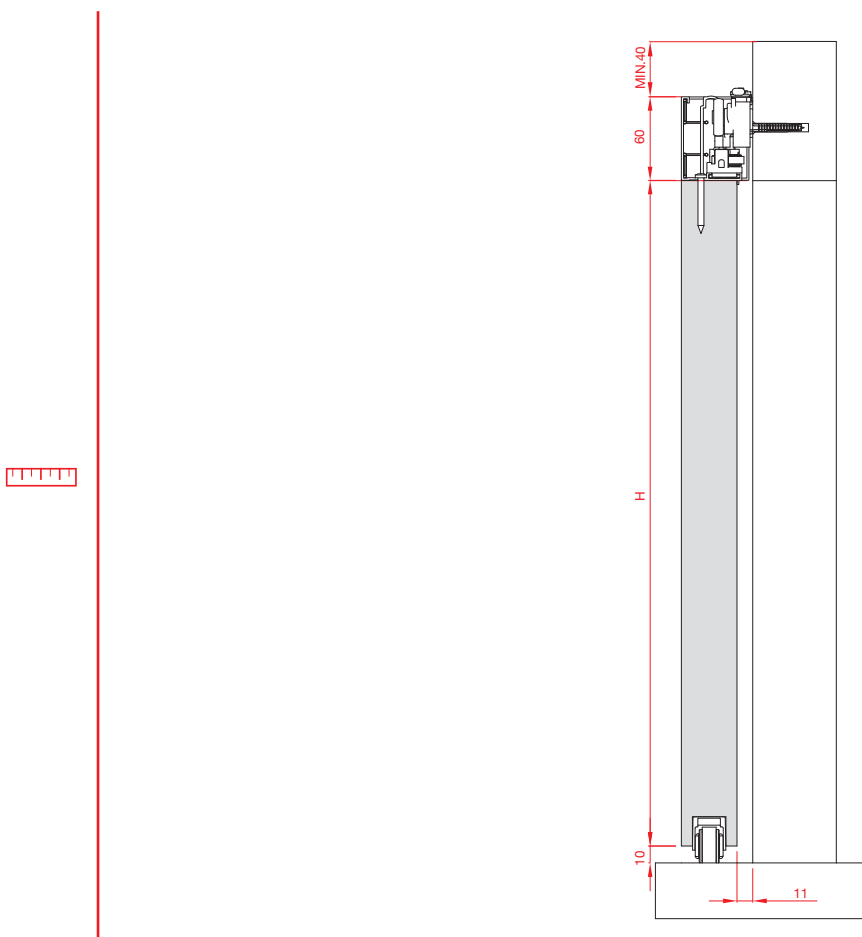

MILLING DESCRIPTION / DESCRIZIONE DELLE LAVORAZIONI

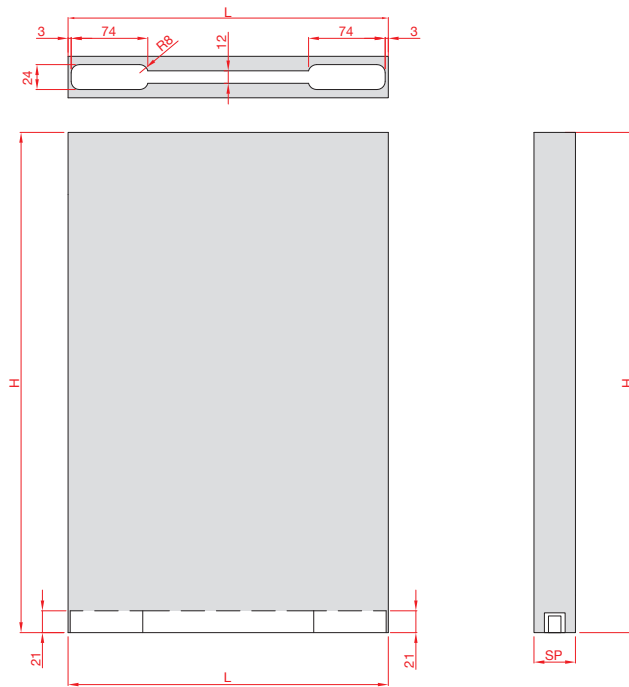

PROFILES CUTTING MEASUREMENTS / MISURE DI TAGLIO DEI PROFILI

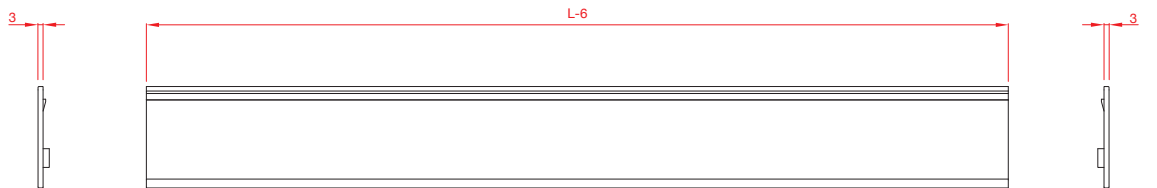
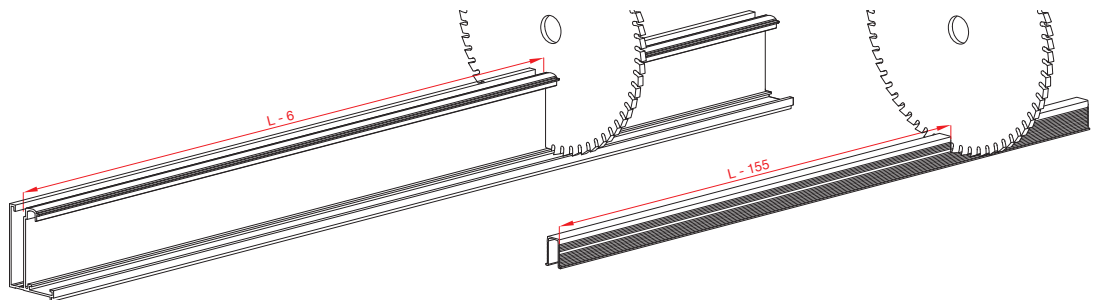

ART. 2898
 ART. 2896

ART. 2870 - ART. 2880

ART. 2898
 ART. 2896

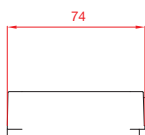

ART. 2858

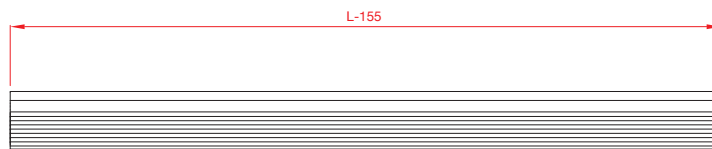

ART. 121

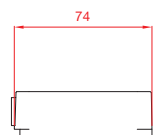

ART. 2858

ACCESSORIES PLACEMENT (STANDARD POSITION) / POSIZIONAMENTO DEGLI ACCESSORI (POSIZIONE STANDARD)

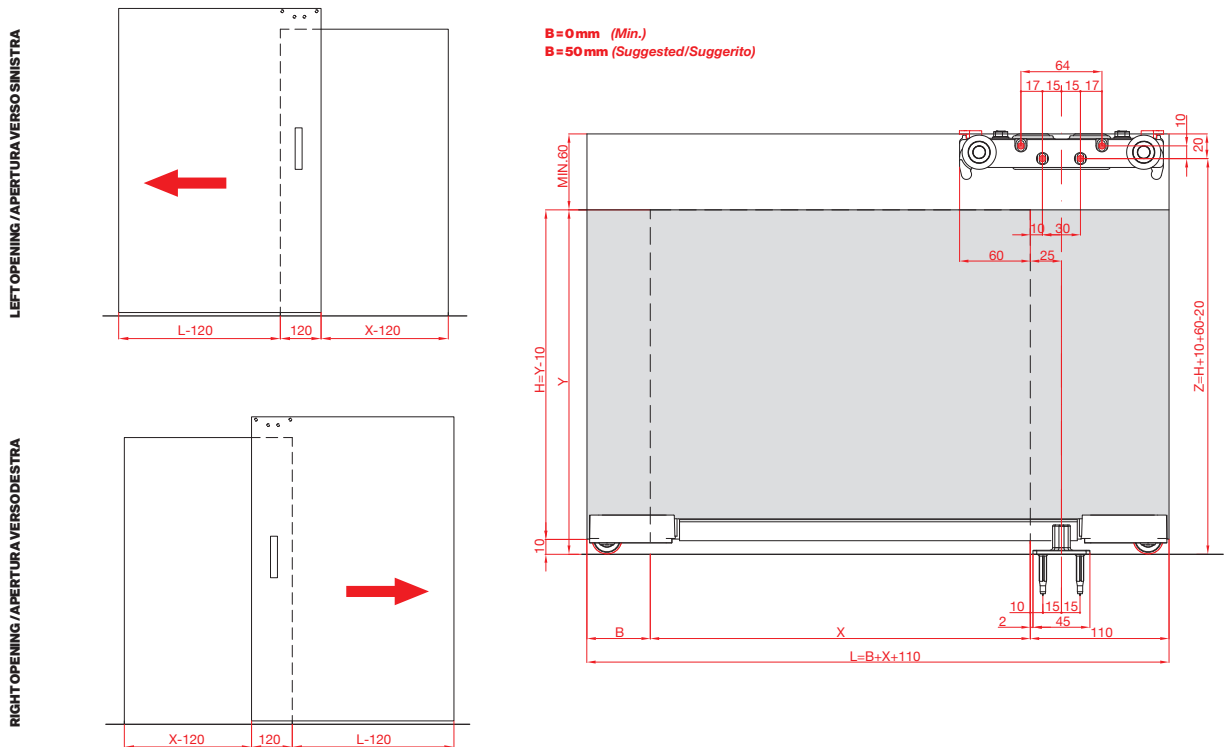

K.0441.1... - K.0441.3... - K.0443.1... - K.0443.3...

B=0
X= MIN. 800 (L=850)
X= MAX. 1050 (L=1100)

B=50
X= MIN. 800 (L=900)
X= MAX. 1000 (L=1100)

K.0441.2... - K.0441.4... - K.0443.2... - K.0443.4...

B=0
X= MIN. 800 (L=850)
X= MAX. 1750 (L=1800)

B=50
X= MIN. 800 (L=900)
X= MAX. 1700 (L=1800)

ACCESSORIES PLACEMENT (INTERMEDIATE POSITION) / POSIZIONAMENTO DEGLI ACCESSORI (POSIZIONE INTERMEDIA)

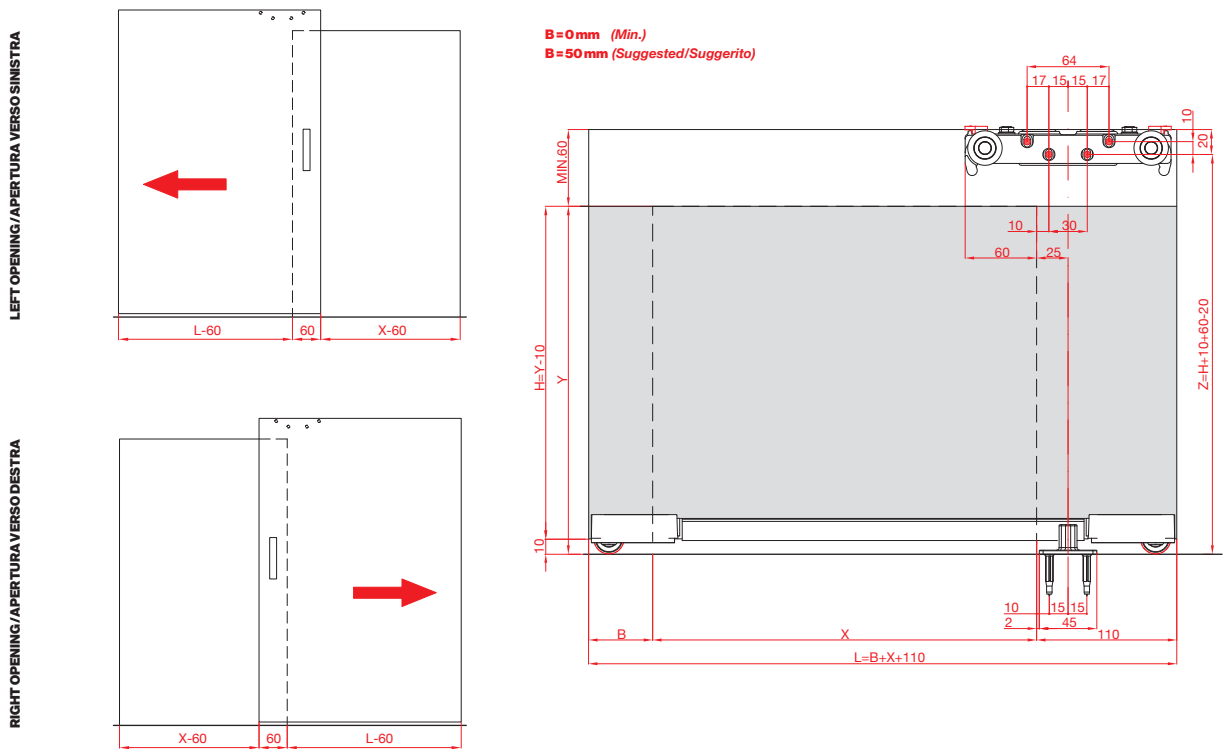

K.0441.1... - K.0441.3... - K.0443.1... - K.0443.3...

B=0
X= MIN. 740 (L=850)
X= MAX. 990 (L=1100)

B=50
X= MIN. 740 (L=900)
X= MAX. 940 (L=1100)

K.0441.2... - K.0441.4... - K.0443.2... - K.0443.4...

B=0
X= MIN. 740 (L=850)
X= MAX. 1690 (L=1800)

B=50
X= MIN. 740 (L=900)
X= MAX. 1640 (L=1800)

ACCESSORIES PLACEMENT (TOTAL OPENING POSITION) / POSIZIONAMENTO DEGLI ACCESSORI (POSIZIONE APERTURA TOTALE)

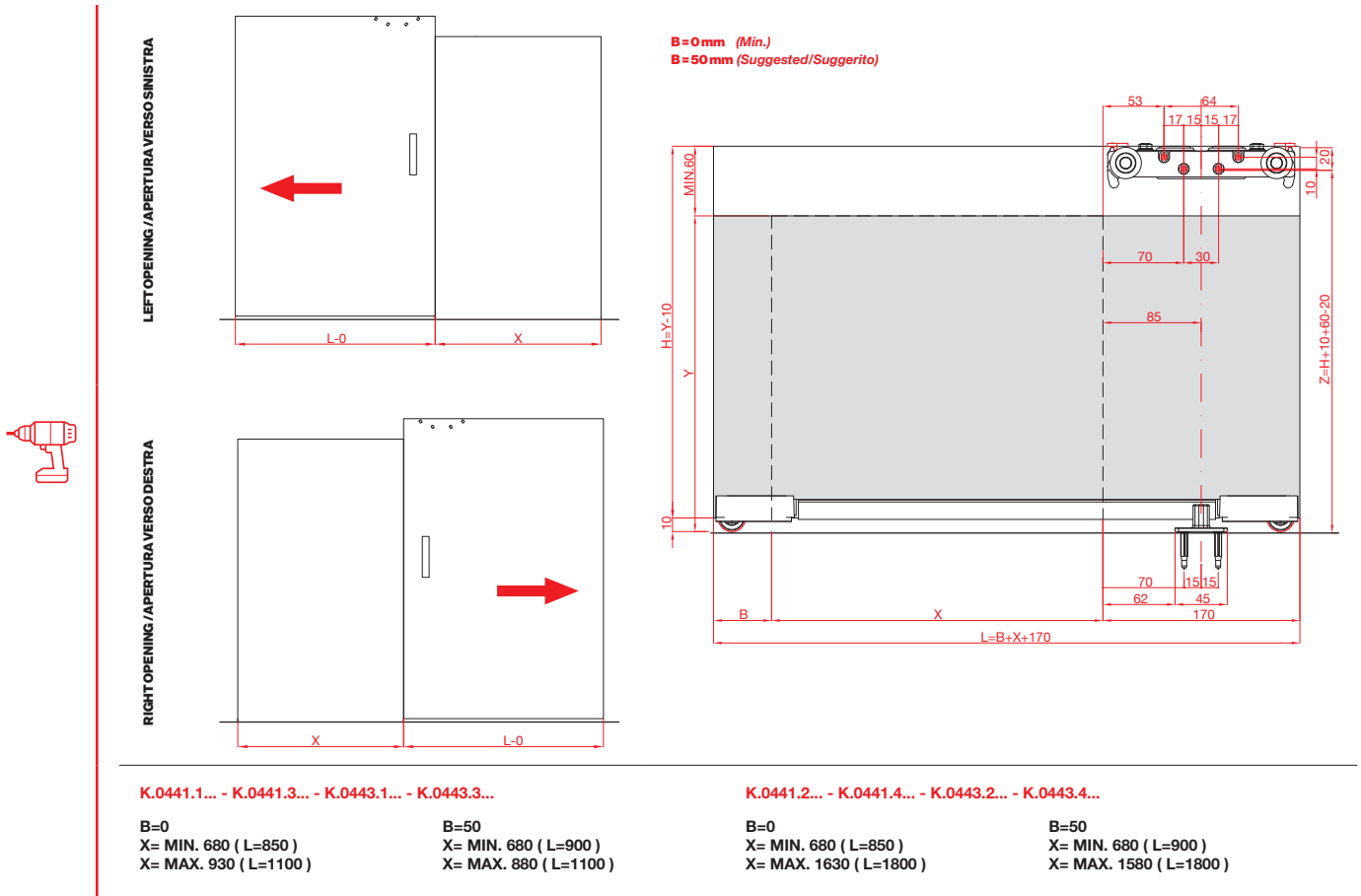

ART. 2859 - END STOPPER / FINE CORSA

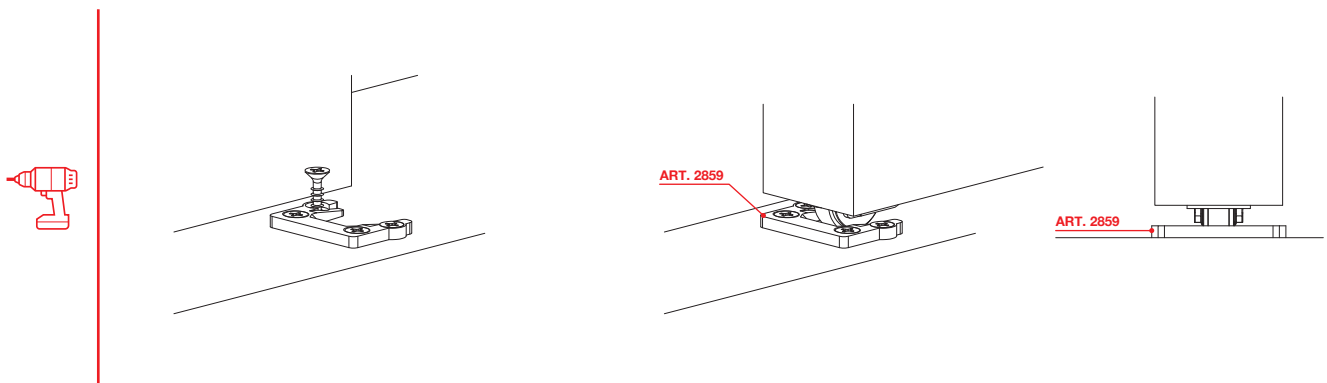

**ALUMINIUM TRACK FOR IRREGULAR FLOOR
PROFILO IN ALLUMINIO PER PAVIMENTAZIONE IRREGOLARE**

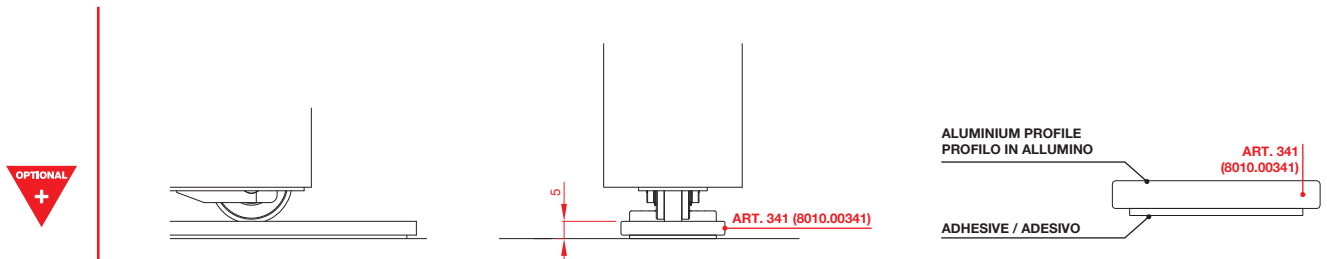

ART. 341
8 01 0 .00341



Magic² Uni

The original invisible sliding doors system
Il sistema invisibile originale per porte scorrevoli



Tracks / Binari

ALUMINUM FINISHES CODES / CODICI FINITURE ALLUMINIO

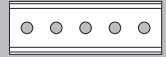

8 ... 0.0

| | | |
|---|---|---|
| 01 • (Anodized Silver / Argento - A) | 13 • (Brushed Anodized Dark Brown / E3 Spazzolato - E3S) | 17 • (Brushed Anodized Nickel / Nichel Spazzolato - NKS) |
| 02 • (Brushed Anodized Silver / Argento Spazzolato - AS) | 14 • (Anodized Black / Nero - N) | 25 • (Brushed Anodized Graphite / Grafite Spazzolato - GRFS) |
| 12 • (Anodized Dark Brown / E3 - E3) | 15 • (Brushed Anodized Black / Nero Spazzolato - NS) | 26 • (Anodized Graphite / Grafite - GRF) |

01 - 02 STANDARD / 12 - 13 - 14 - 15 - 17 - 25 - 26 SPECIAL

Magic2

COMPLETE BOX KIT / KIT COMPLETO IN SCATOLA



K Complete kit / Kit completo

| | | |
|------|--|-------------------------------------|
| 0031 | | Magic2 - Wood Magic2 - Legno |
| 1 | | 1100 mm |
| 2 | | 1800 mm |
| 01 | | Standard Finish / Finitura Standard |

Magic2 Frame

COMPLETE BOX KIT / KIT COMPLETO IN SCATOLA



K Complete kit / Kit completo

| | | |
|------|--|--|
| 0461 | | 1500 mm - 80kg |
| 0462 | | 1100 mm - 80kg |
| 1 | | N.2 Soft damper stoppers N.2 Fermi ammortizzati |
| 1 | | 2200 mm |
| 2 | | 2600 mm |
| 3 | | 3000 mm |
| 02 | | Brushed Anodized Silver / Argento Spazzolato |
| 13 | | Brushed Anodized Dark Brown / E3 Spazzolato |
| 15 | | Brushed Anodized Black / Nero Spazzolato |
| 17 | | Brushed Anodized Nickel / Nichel Spazzolato |
| 25 | | Brushed Anodized Graphite / Grafite Spazzolato |

Magic2 Vetro

COMPLETE BOX KIT / KIT COMPLETO IN SCATOLA



K Complete kit / Kit completo

| | | |
|------|--|--|
| 0041 | | 1100 mm - 80kg |
| 0042 | | 1800 mm - 80kg |
| 1 | | Glass thk. / Vetri sp. 8 mm (5/16") |
| 2 | | Glass thk. / Vetri sp. 10 mm (3/8") |
| 3 | | Glass thk. / Vetri sp. 12 mm (1/2") |
| 02 | | Brushed Anodized Silver / Argento Spazzolato |



Magic2 Mix

COMPLETE BOX KIT / KIT COMPLETO IN SCATOLA

| | | |
|----------|-----------------------------|--|
| K | Complete kit / Kit completo | |
| | . | |
| | 0441 | Magic2 MIX UP |
| | 0442 | Magic2 MIX DOWN |
| | 0443 | Magic2 MIX UP |
| | 0444 | Magic2 MIX DOWN |
| | . | |
| | 1 | 1100 mm → 38-40 mm |
| | 2 | 1800 mm → 38-40 mm |
| | 3 | 1100 mm → 42-44 mm |
| | 4 | 1800 mm → 42-44 mm |
| | . | |
| | 02 | Brushed Anodized Silver / Argento Spazzolato |
| | 15 | Brushed Anodized Black / Nero Spazzolato |

Magic2 Uni

COMPLETE BOX KIT / KIT COMPLETO IN SCATOLA



| | | |
|----------|-----------------------------|--|
| K | Complete kit / Kit completo | |
| | . | |
| | 0451 | 40 mm - 30 kg |
| | 0452 | 44 mm - 30 kg |
| | 0453 | 40 mm - 80 kg |
| | 0454 | 44 mm - 80 kg |
| | . | |
| | 1 | 1100 mm |
| | 2 | 1800 mm |
| | . | |
| | 02 | Brushed Anodized Silver / Argento Spazzolato |
| | 15 | Brushed Anodized Black / Nero Spazzolato |

EXAMPLE / ESEMPIO

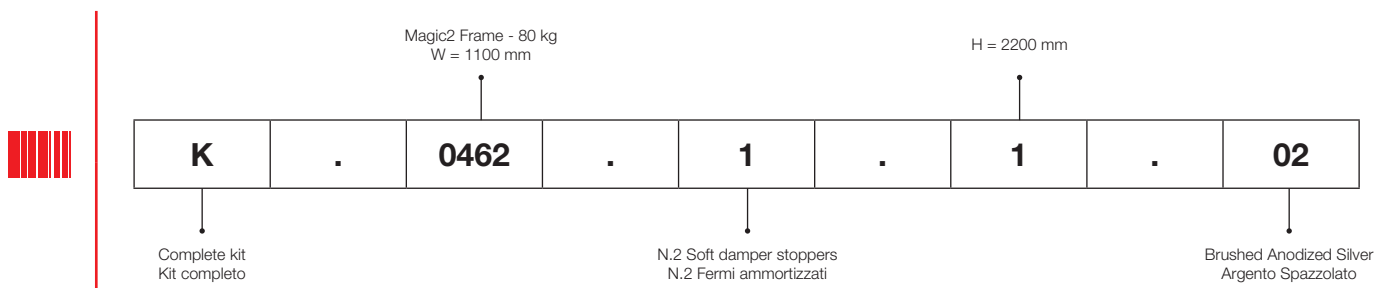

More than 50mm of damping motion

Magic2 system integrates new **PATENTED** dampers with 50 mm of braking motion, 20 mm longer than previous version of **Magic**, while keeping the same door dimensions.

Oltre 50 mm di frenatura

Il sistema **Magic2** integra nuovi fermi ammortizzati **BREVETTATI**, per una frenatura di oltre 50 mm, più di 20 mm rispetto al fermo del modello **Magic**, mantenendo gli stessi ingombri della porta.

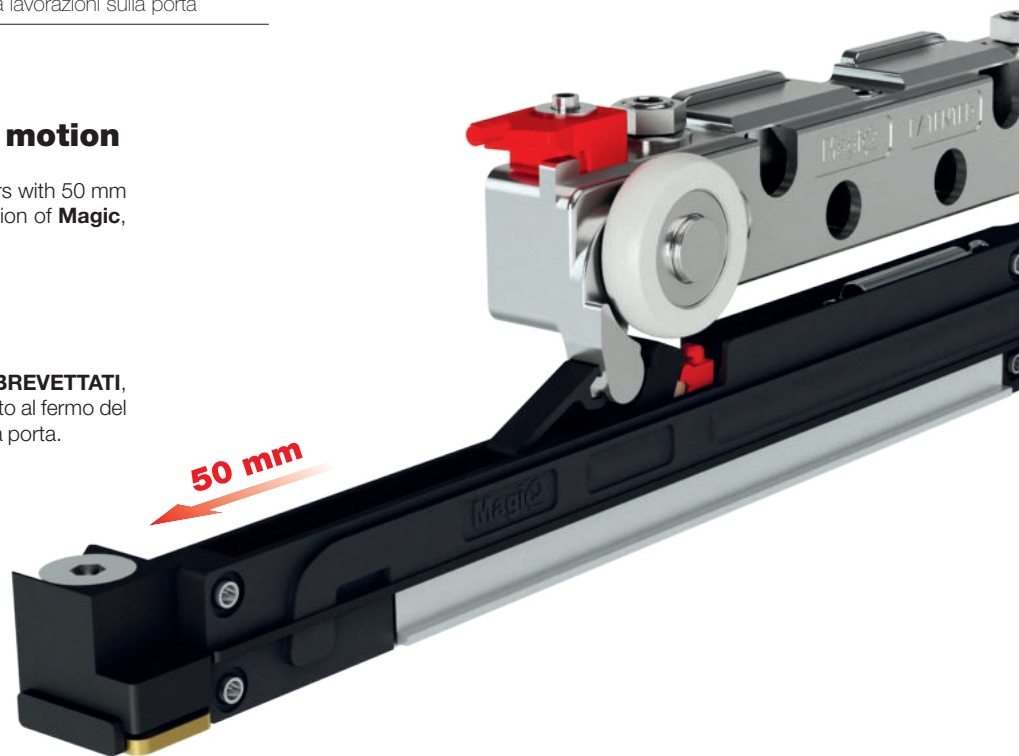

PATENTED

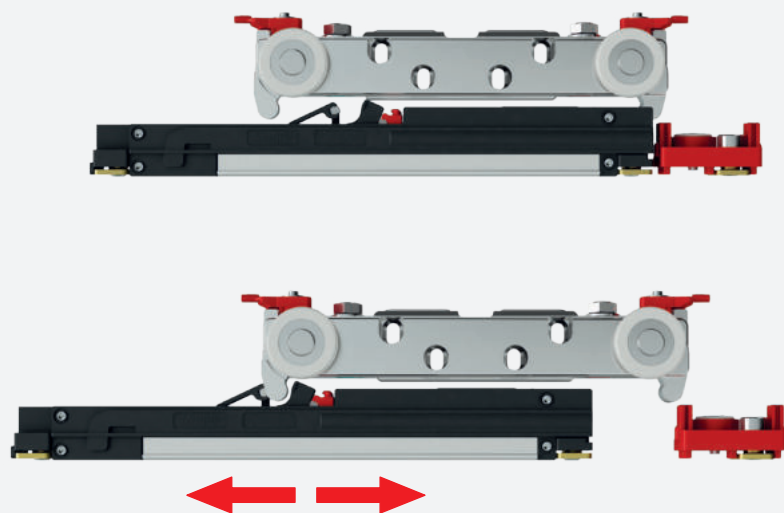

New dampers with adjustable positioning

New **Magic2** adjustable dampers were designed to be independent from wall-spacer wheels. New dampers are suitable to be moved into the track to allow door positioning adjustment.

Nuovi fermi con posizione regolabile

I nuovi fermi del **Magic2** sono stati progettati per essere indipendenti dal distanziale. All'occorrenza si possono spostare per regolare la posizione della porta.

New position of wall-spacer wheels

In **Magic2** system wall-spacer wheels are positioned on the door extremities. The wall-spacer wheels are so positioned in order to protect the door from wall contact, when wall surface are not plane.

Nuova posizione per le ruote distanziali

Nel sistema **Magic2** le ruote distanziali sono posizionate alle estremità della porta. Le ruote distanziali così posizionate proteggono la porta da contatti con la parete, in caso di muri con superfici irregolari.



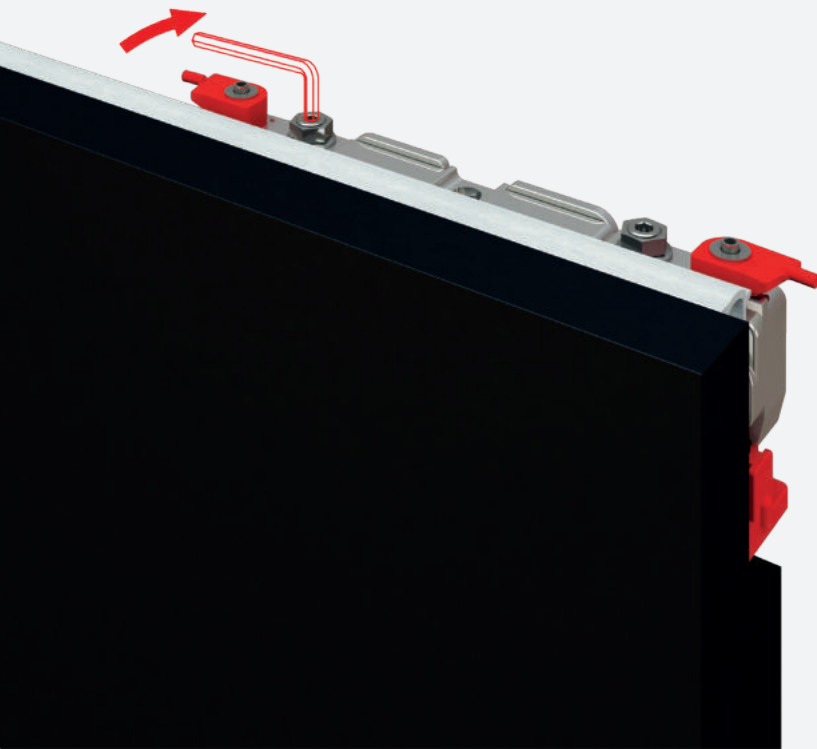

New patented adjustment system

New **Magic² PATENTED** sliding trolley integrates following door adjustments:

- Door height adjustment from floor
- Micrometric adjustment of door from wall
- Micrometric adjustment of door parallelism from wall

Door adjustments of wall distance and parallelism, are meant to compensate possible irregularities of wall. All adjustments are available in the top of sliding trolley, without removing the door.

Nuovo sistema brevettato di regolazione

Il nuovo scorrevole **Magic² BREVETTATO** integra le seguenti regolazioni:

- Regolazione dell'altezza della porta dal pavimento
- Regolazione micrometrica della distanza della porta dalla parete
- Regolazione micrometrica del parallelismo della porta rispetto alla parete

Le regolazioni di distanza e parallelismo della porta, si utilizzano per compensare eventuali irregolarità della parete. Tutte le regolazioni si realizzano dalla parte superiore dello scorrevole, senza sganciare la porta.

Practical anti-jumping system

Magic² sliding trolley includes two new turning anti-jumping activation elements. Turning anti-jumping activation elements are equipped with two safety levers, easy to rotate with no tools required. Safety levers, clearly visible, will have to be removed once anti-jumping system is activated in order to insert end caps.

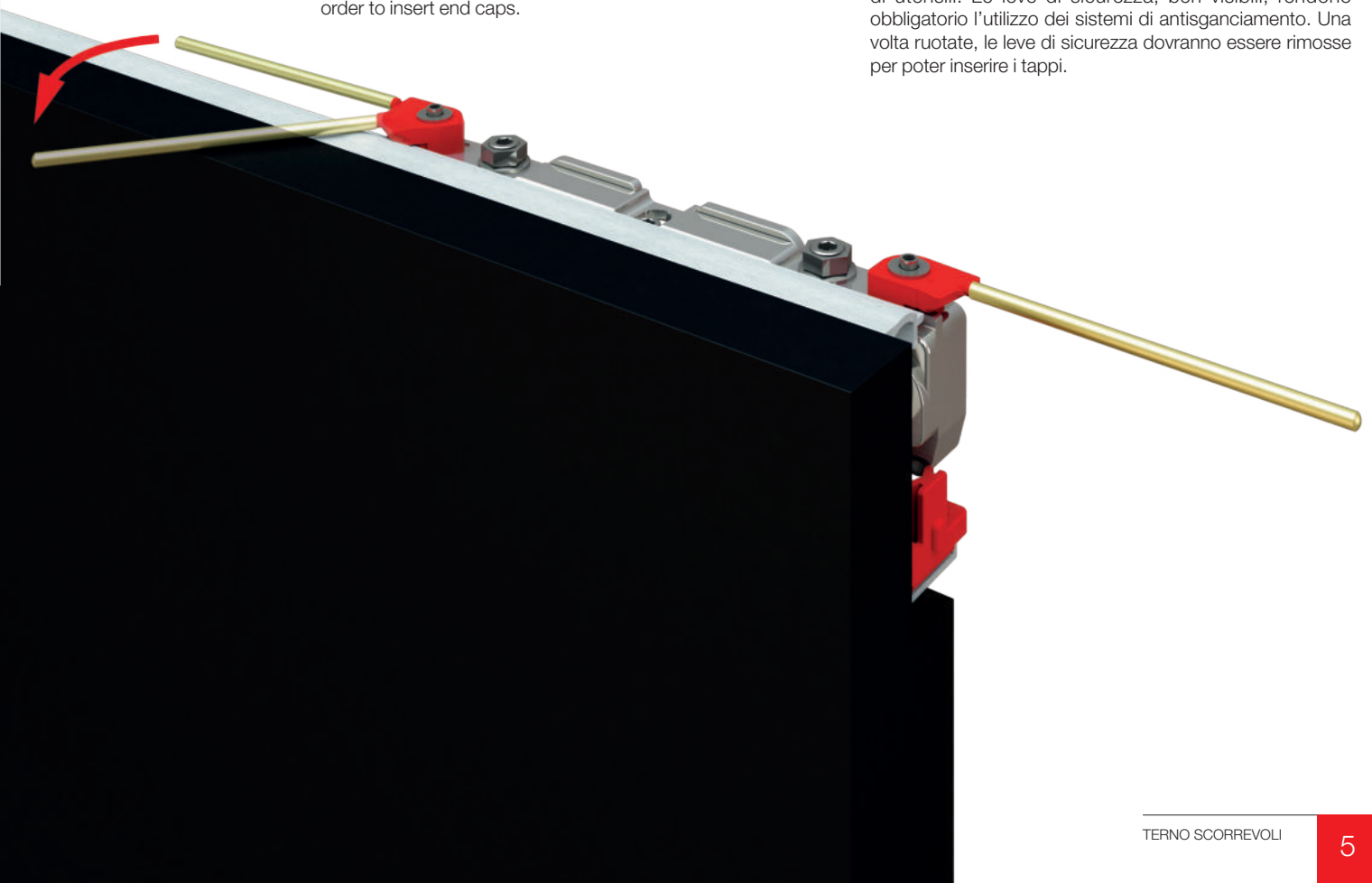

Pratico sistema di antisganciamento

Lo scorrevole **Magic²** comprende due nuovi elementi rotanti di antisganciamento. In questi nuovi elementi sono inserite due leve di sicurezza, per ruotarli senza l'utilizzo di utensili. Le leve di sicurezza, ben visibili, rendono obbligatorio l'utilizzo dei sistemi di antisganciamento. Una volta ruotate, le leve di sicurezza dovranno essere rimosse per poter inserire i tappi.

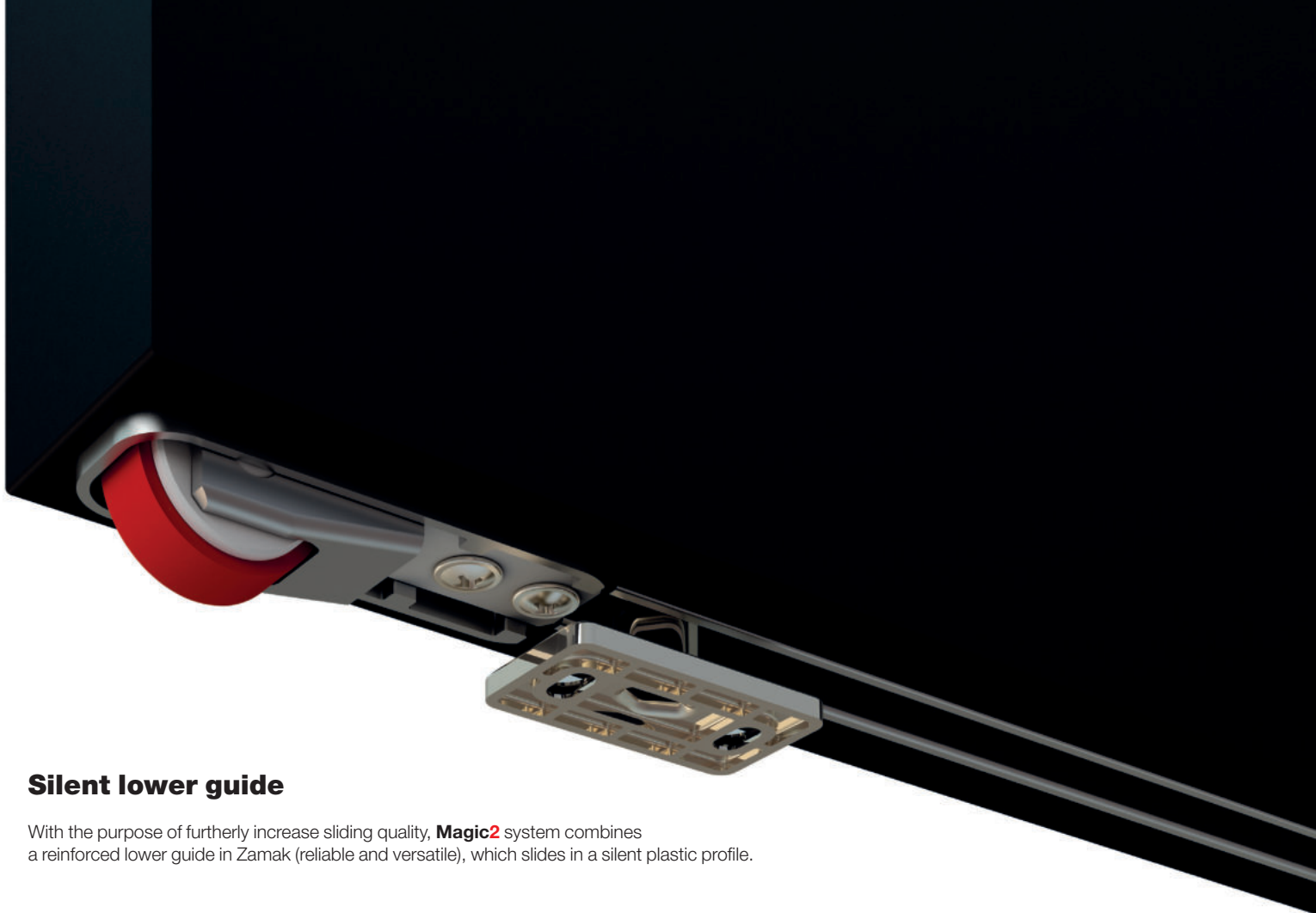

Silent lower guide

With the purpose of furtherly increase sliding quality, **Magic2** system combines a reinforced lower guide in Zamak (reliable and versatile), which slides in a silent plastic profile.

Guida inferiore silenziosa

Per migliorare ancor di più lo scorrimento, il sistema **Magic2** integra una guida inferiore rinforzata in zama (resistente e versatile), che scorre in un profilo in plastica molto silenzioso.

New patented bottom wheels designed for a better sliding

New **Magic2** bottom wheels are equipped with a **PATENTED** suspension spring system and were designed with a larger diameter, bigger bearing and steel pivots. Rubber surface have been enlarged as well, in order to reinforce wheels and improve sliding quality.

An additional important **PATENTED** innovation in lower sliding system is the introduction of two padded fixed springs which can grant damping function during door motion up to 40kg. Over 40kg of door weight and up to 80kg of maximum load capacity, new bottom wheels will be more flexible than previous version, with their Zamak surface to lean on a rubber internal cylinder, which act as a small shock absorber, granting more stability during sliding motion.

The **Magic2** wheels rubber have high performance:

- it does not leave any trace or sign on sliding surface like floors and walls
- it does not deform over time

Ruote inferiori brevettate per una migliore scorrevolezza

Le nuove ruote inferiori del sistema **Magic2** hanno molleggio **BREVETTATO**, e sono state progettate con diametro, cuscinetti e perni in acciaio maggiorati. Anche il rivestimento in gomma è stato raddoppiato per aumentare la forza e la scorrevolezza delle ruote.

Un'altra importante innovazione **BREVETTATA** nel sistema di scorrimento inferiore è l'inserimento di due molle fisse maggiorate che permettono di ammortizzare il movimento della porta fino ad una portata di 40 kg. Oltre i 40 kg, e fino ad un massimo di 80 kg, queste nuove ruote flettono maggiormente e la superficie realizzata in zama si appoggia su di un cilindro di gomma interno che funge da ammortizzatore supplementare garantendo maggior stabilità.

La gomma delle ruote di **Magic2** è altamente performante:

- non lascia traccia sulle superfici di scorrimento come pavimenti e pareti
- non si deforma nel tempo

KG 0 < KG 40

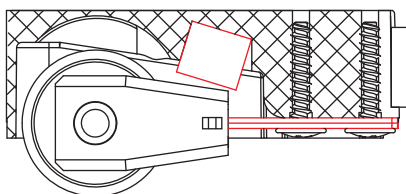

KG 40 < KG 80

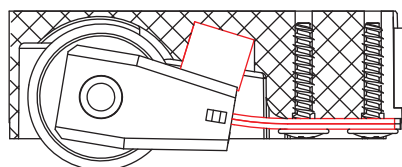

Built-in sliding track with not-through milling

Upper sliding track can be installed "built-in" into a blind milling. Laterally, track's end caps won't be visible, improving even more the aesthetics of door. Door installation and adjustment are not going to be different than usual, because available on the top of the door.

Binario incassato in fresata non passante

Il binario superiore può essere incassato in una fresata cieca. Lateralmente non saranno visibili i tappi del binario, migliorando ulteriormente l'estetica della porta. L'installazione e regolazione della porta non variano perché le regolazioni si effettuano dal lato superiore della porta.

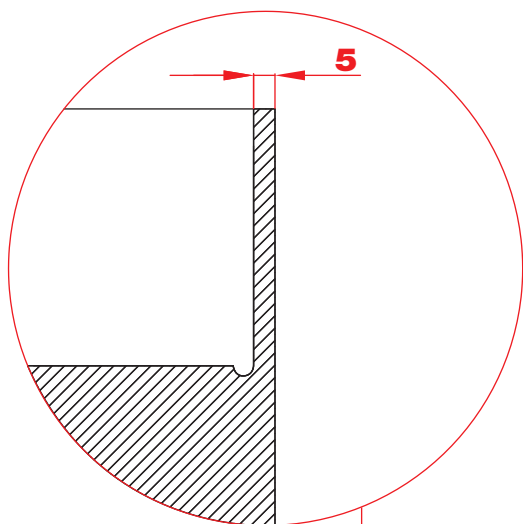

Magic² Uni

PATENTED

Magic² Uni integrates all innovative features of **Magic²** system, but it also allows to use the system with economical industrial laminated panels with fixed standard height. Thanks to **Magic² Uni** all additional milling processing on the door have been totally eliminated. The tracks, indeed, are directly screwed on the top and on the bottom edge of the door. With **Magic² Uni** system is possible to realize standard doors with thickness from 38 to 44 mm.

Magic² Uni comprende tutte le caratteristiche innovative del sistema **Magic²**, ma si differenzia per la possibilità di utilizzare il sistema con pannelli economici in laminato industriale con altezza standard. Grazie a **Magic² Uni**, vengono completamente eliminate le lavorazioni di fresatura sulla porta: i binari, infatti, sono avvitati direttamente sia nella parte superiore che nella parte inferiore della porta. Con il sistema **Magic² Uni** si possono utilizzare porte standard con spessori da 38 a 44 mm.



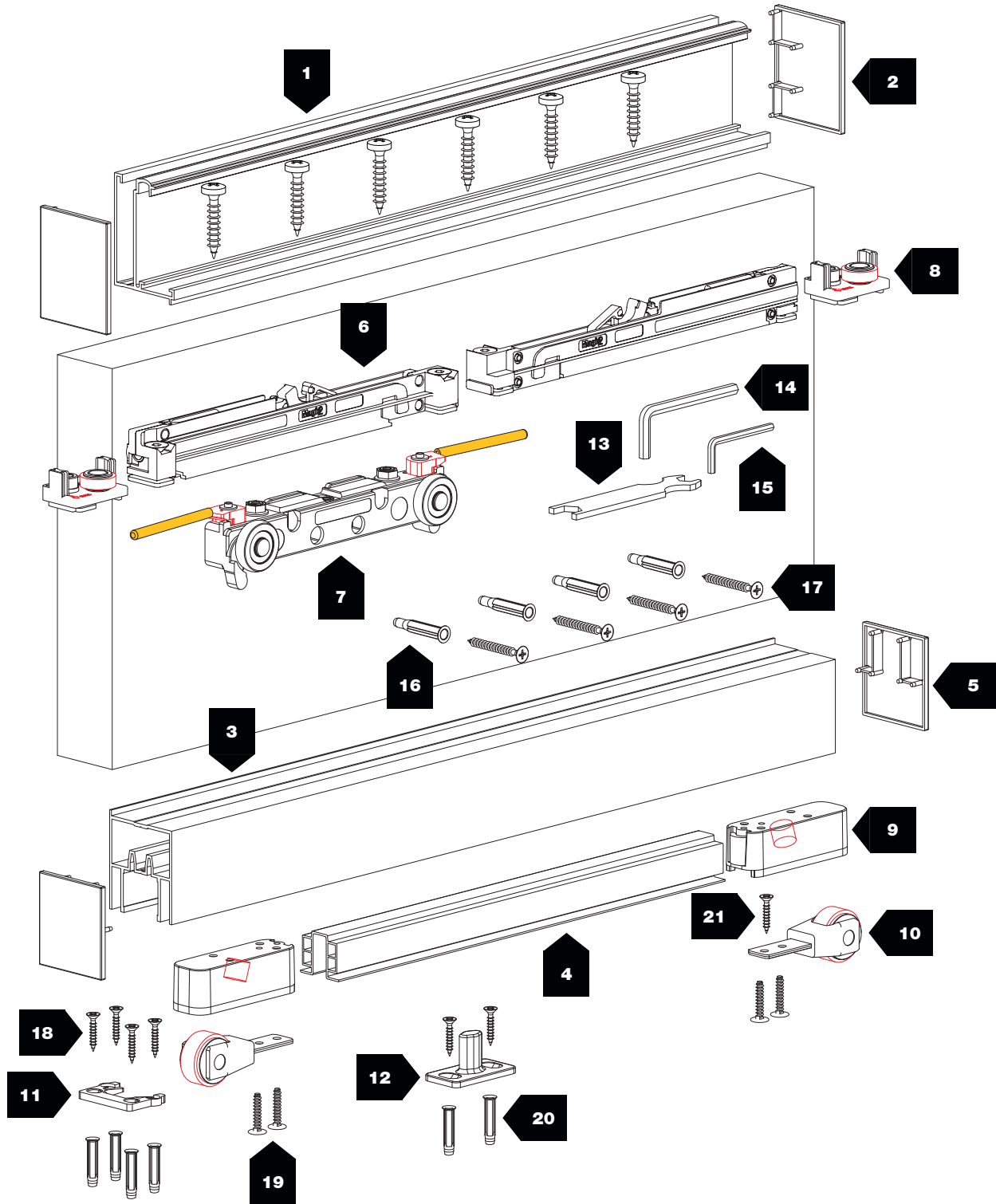



38 ÷ 44 mm











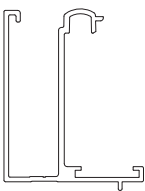
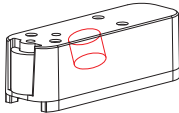

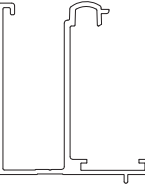
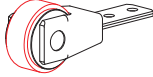

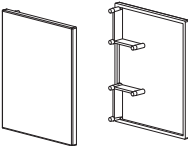
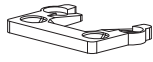
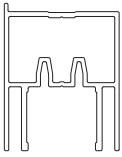
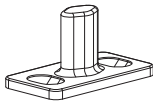
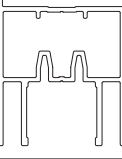
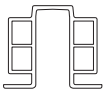
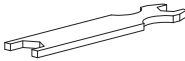
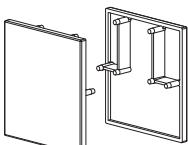
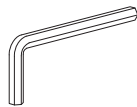

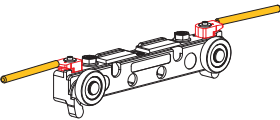

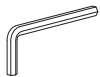
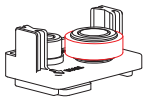
40 ÷ 80 kg

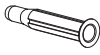
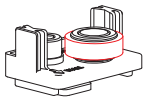
10 mm

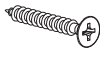
COLORS / COLORI

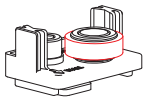
 Brushed Anodized Silver
Argento Spazzolato

 Brushed Anodized Black
Nero Spazzolato

| N° | | | kg | | N° | | | kg | |
|---------|---------|---|-------|---|--------|---|---|--------|---|
| 1 | 2870 |  | - | 38-40 mm | 9 | 2858 |  | 40-80 |  |
| | 2880 |  | - | 42-44 mm | 10 | 2857 |  | 40-80 |  |
| 2 | 2898 |  | - | 38-40 mm | 11 | 2859 |  | - | |
| | 2896 | | - | 42-44 mm | | | | | |
| 3 | 2888 |  | - | 38-40 mm | 12 | 2855 |  | - | |
| | 2890 |  | - | 42-44 mm | | | | | |
| 4 | 2860 |  | - | | 13 | 1025 |  | - | |
| 5 | 2894 |  | - | 38-40 mm | 14 | 538 |  | - | |
| | 2892 | | - | 42-44 mm | | | | | |
| | 2864-40 | | 40 |  | | | | | |
| 2864-80 | 80 | | | | | | | | |
| 6 | 2852 |  | 40-80 |  | 15 | 654 |  | - | |
| 7 | 2856 |  | - |  | 16 | FISCHER UX6 |  | - | |
| | | | 17 | | | | | 4,5x40 | |
| 8 | 2856 |  | - |  | 18 | 4x30 |  | - | |
| | | | 19 | | 4x20 |  | - | | |
| 8 | 2856 |  | - |  | 20 | FISCHER SX5 |  | - | |
| | | | 21 | | 3,9x13 |  | - | | |

 N.2 Soft damper stoppers
N.2 Fermi ammortizzati

 Customizable door width
Larghezza porta personalizzabile

 Patented system
Sistema brevettato

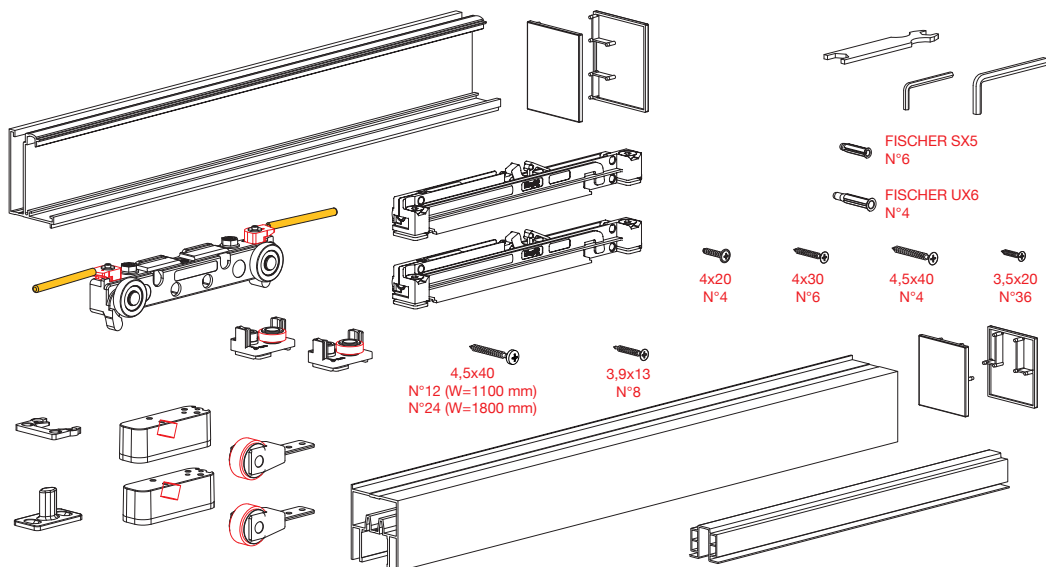

| CODE | COLOURS / COLORI | |  |  |  |  |
|-----------------------------------|------------------|-----|--|---|---|---|
| | AS | NS | | | | |
| K.0451.1 <input type="checkbox"/> | .02 | .15 | 40 kg | 38-40 mm | 1100 mm | 6x |
| K.0452.1 <input type="checkbox"/> | .02 | .15 | | 42-44 mm | | 6x |
| K.0451.2 <input type="checkbox"/> | .02 | .15 | | 38-40 mm | 1800 mm | 4x |
| K.0452.2 <input type="checkbox"/> | .02 | .15 | | 42-44 mm | | 4x |
| K.0453.1 <input type="checkbox"/> | .02 | .15 | 80 kg | 38-40 mm | 1100 mm | 6x |
| K.0454.1 <input type="checkbox"/> | .02 | .15 | | 42-44 mm | | 6x |
| K.0453.2 <input type="checkbox"/> | .02 | .15 | | 38-40 mm | 1800 mm | 4x |
| K.0454.2 <input type="checkbox"/> | .02 | .15 | | 42-44 mm | | 4x |

MEASUREMENTS DESCRIPTION / DESCRIZIONE MISURE

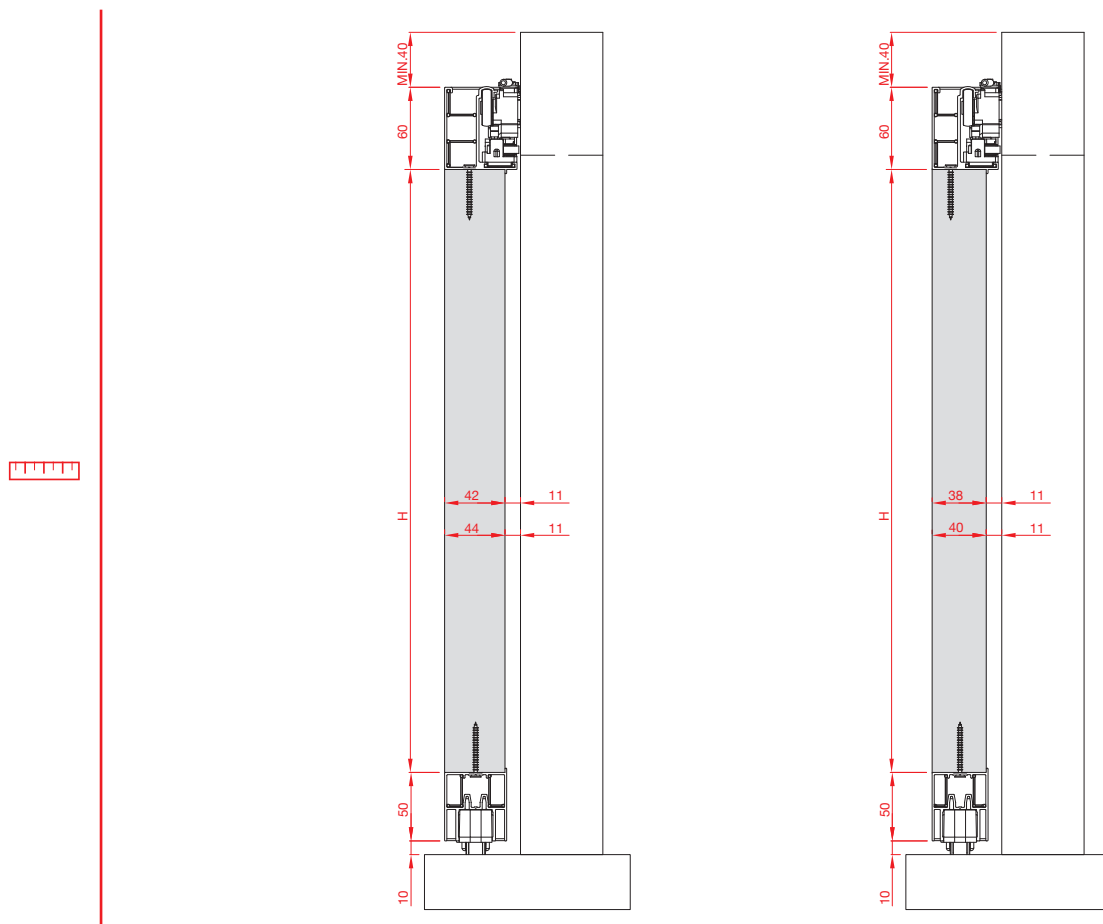

MILLING DESCRIPTION / DESCRIZIONE DELLE LAVORAZIONI

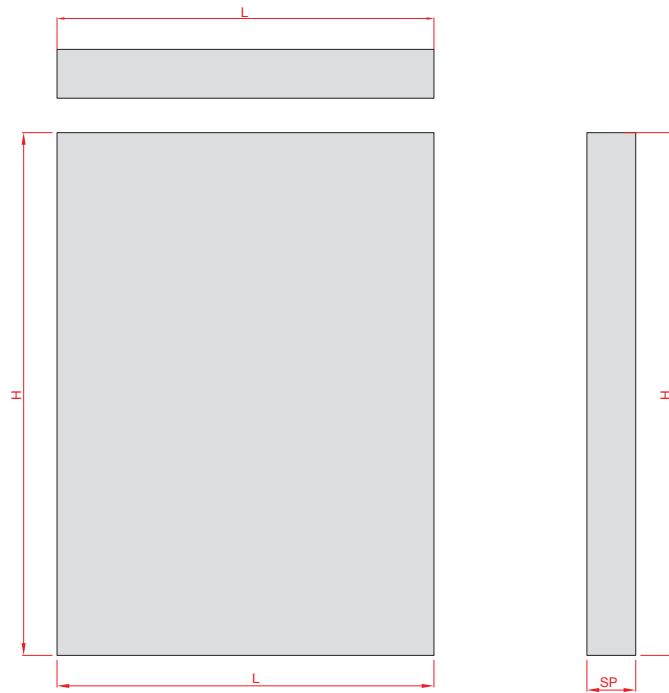

PROFILES CUTTING MEASUREMENTS / MISURE DI TAGLIO DEI PROFILI

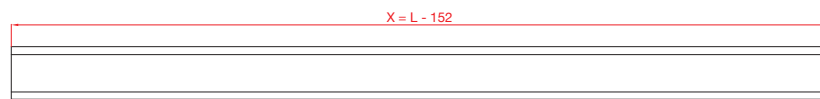
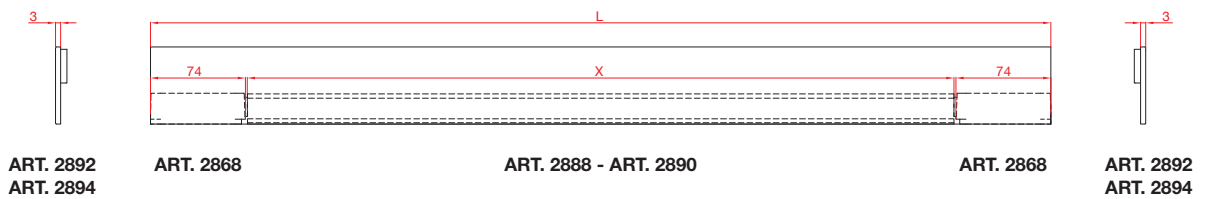
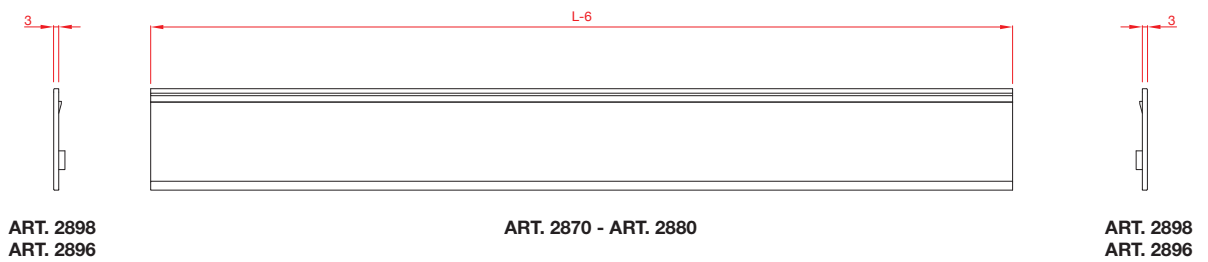
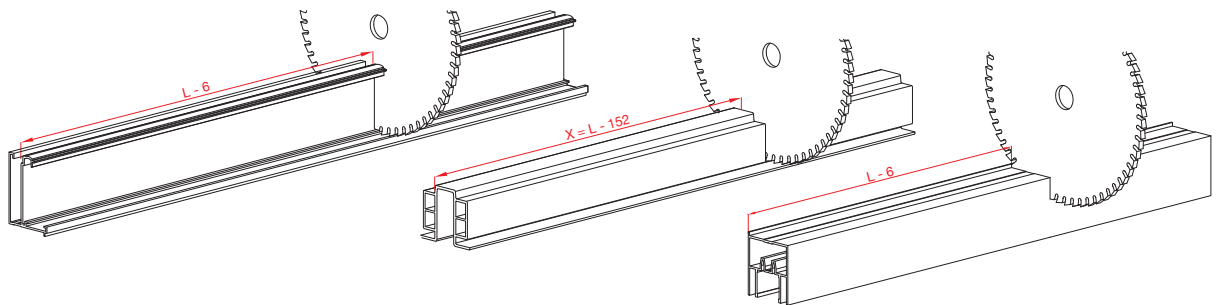

ART. 2860

ACCESSORIES PLACEMENT (STANDARD POSITION) / POSIZIONAMENTO DEGLI ACCESSORI (POSIZIONE STANDARD)

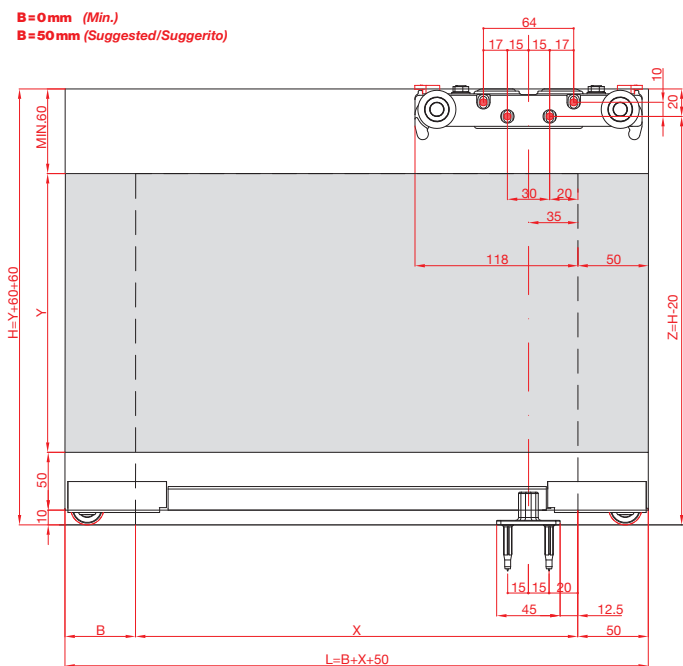
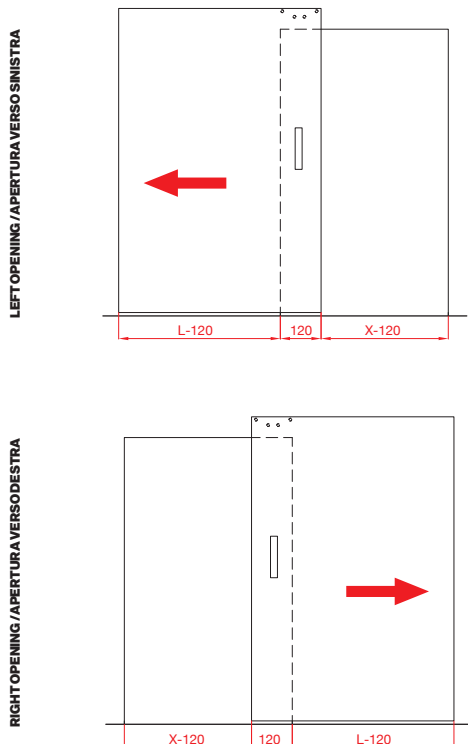

K.0451.1... - K.0452.1... - K.0453.1... - K.0454.1...

B=0
X= MIN. 800 (L=850)
X= MAX. 1050 (L=1100)

B=50
X= MIN. 800 (L=900)
X= MAX. 1000 (L=1100)

K.0451.2... - K.0452.2... - K.0453.2... - K.0454.2...

B=0
X= MIN. 800 (L=850)
X= MAX. 1750 (L=1800)

B=50
X= MIN. 800 (L=900)
X= MAX. 1700 (L=1800)

ACCESSORIES PLACEMENT (INTERMEDIATE POSITION) / POSIZIONAMENTO DEGLI ACCESSORI (POSIZIONE INTERMEDIA)

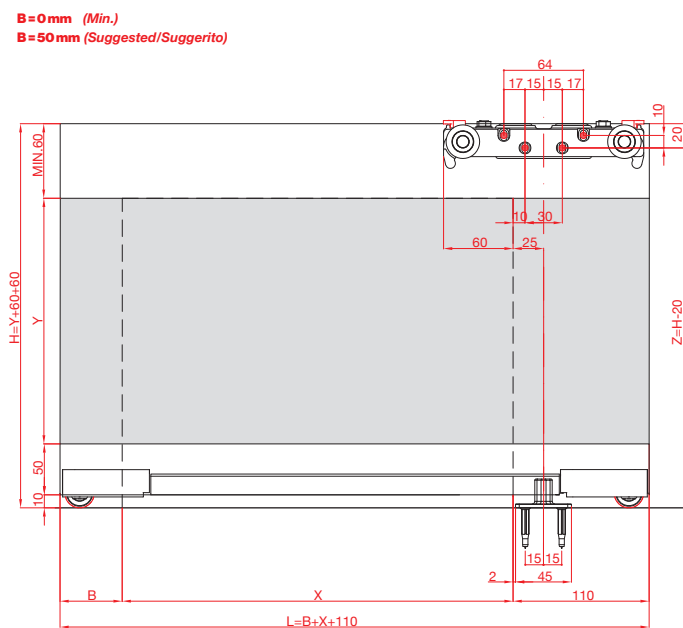
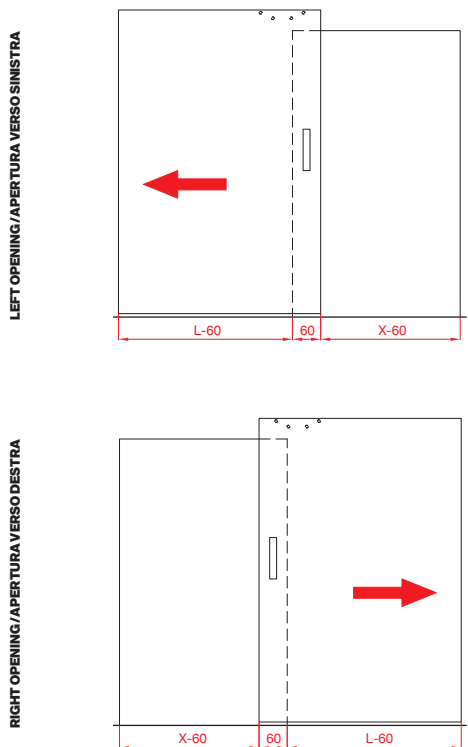

K.0451.1... - K.0452.1... - K.0453.1... - K.0454.1...

B=0
X= MIN. 740 (L=850)
X= MAX. 990 (L=1100)

B=50
X= MIN. 740 (L=900)
X= MAX. 940 (L=1100)

K.0451.2... - K.0452.2... - K.0453.2... - K.0454.2...

B=0
X= MIN. 740 (L=850)
X= MAX. 1690 (L=1800)

B=50
X= MIN. 740 (L=900)
X= MAX. 1640 (L=1800)

ACCESSORIES PLACEMENT (TOTAL OPENING POSITION) / POSIZIONAMENTO DEGLI ACCESSORI (POSIZIONE APERTURA TOTALE)

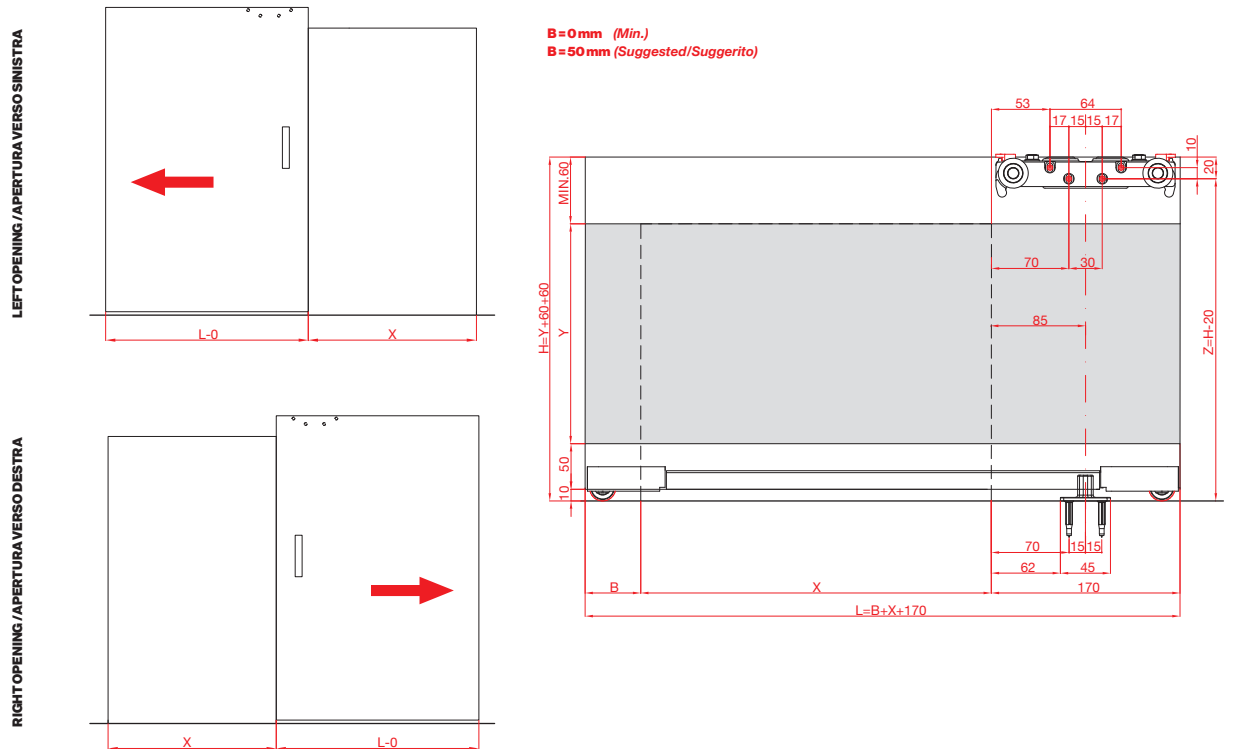

K.0451.1... - K.0452.1... - K.0453.1... - K.0454.1...

B=0
X= MIN. 680 (L=850)
X= MAX. 930 (L=1100)

B=50
X= MIN. 680 (L=900)
X= MAX. 880 (L=1100)

K.0451.2... - K.0452.2... - K.0453.2... - K.0454.2...

B=0
X= MIN. 680 (L=850)
X= MAX. 1630 (L=1800)

B=50
X= MIN. 680 (L=900)
X= MAX. 1580 (L=1800)

ART. 2859 - END STOPPER / FINE CORSA

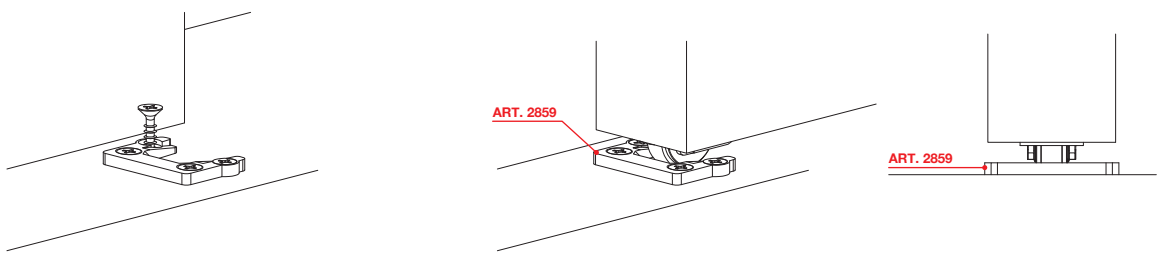

**ALUMINIUM TRACK FOR IRREGULAR FLOOR
PROFILO IN ALLUMINIO PER PAVIMENTAZIONE IRREGOLARE**

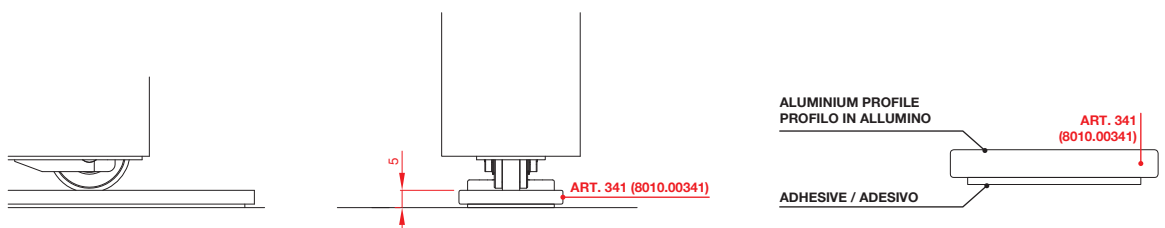

ART. 341
8 01 0 .00341



Magic²

VETRO

The original invisible sliding doors system
Il sistema invisibile originale per porte scorrevoli

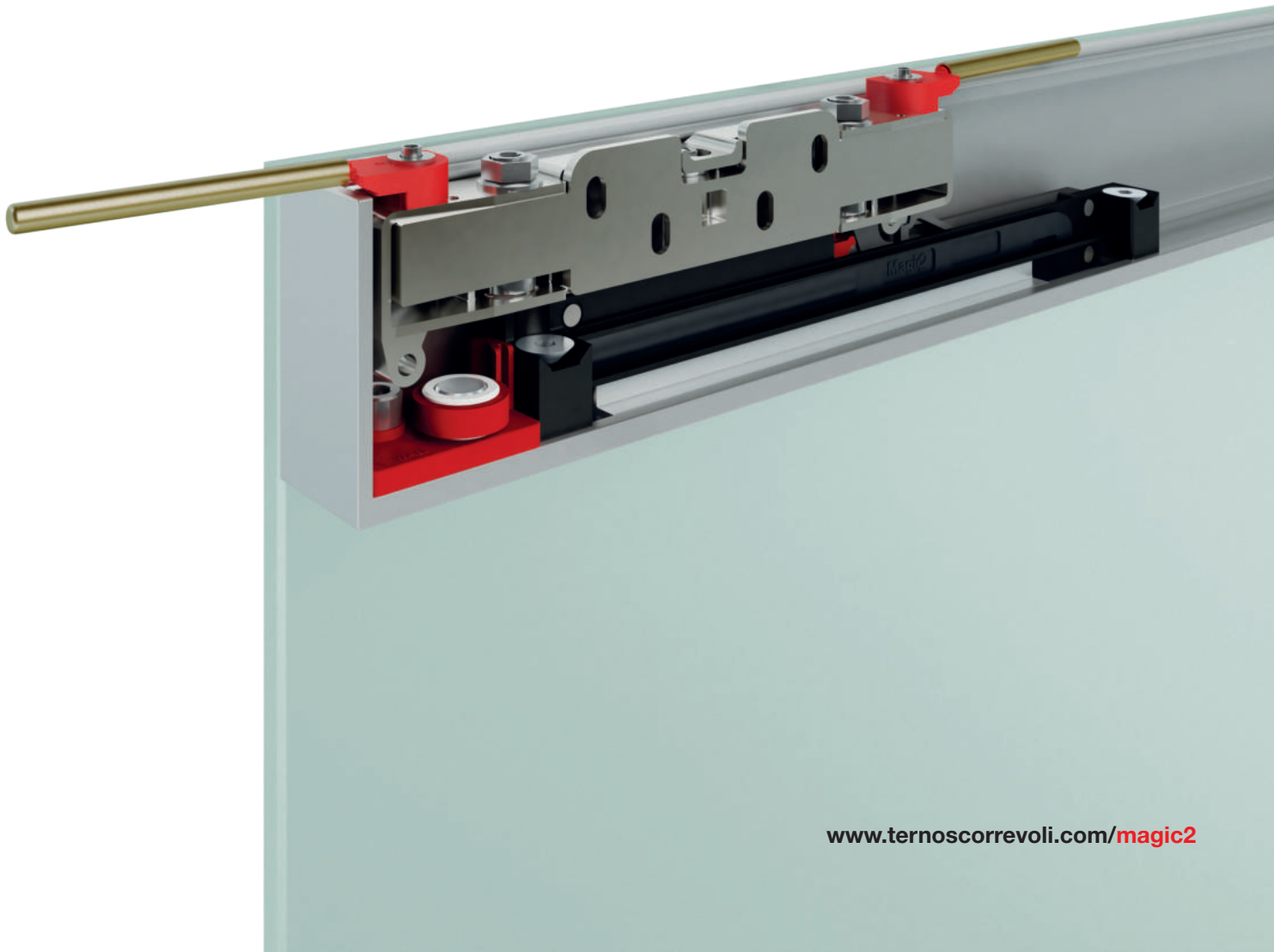

Tracks / Binari

ALUMINUM FINISHES CODES / CODICI FINITURE ALLUMINIO



8 ... 0.0

| | | |
|---|---|---|
| 01 • (Anodized Silver / Argento - A) | 13 • (Brushed Anodized Dark Brown / E3 Spazzolato - E3S) | 17 • (Brushed Anodized Nickel / Nichel Spazzolato - NKS) |
| 02 • (Brushed Anodized Silver / Argento Spazzolato - AS) | 14 • (Anodized Black / Nero - N) | 25 • (Brushed Anodized Graphite / Grafite Spazzolato - GRFS) |
| 12 • (Anodized Dark Brown / E3 - E3) | 15 • (Brushed Anodized Black / Nero Spazzolato - NS) | 26 • (Anodized Graphite / Grafite - GRF) |

01 - 02 STANDARD / 12 - 13 - 14 - 15 - 17 - 25 - 26 SPECIAL

Magic2

COMPLETE BOX KIT / KIT COMPLETO IN SCATOLA



K Complete kit / Kit completo

| | | |
|------|-------------------------------------|---------------------------------|
| 0031 | | Magic2 - Wood Magic2 - Legno |
| 1 | | 1100 mm |
| 2 | | 1800 mm |
| 01 | Standard Finish / Finitura Standard | |

Magic2 Frame

COMPLETE BOX KIT / KIT COMPLETO IN SCATOLA



K Complete kit / Kit completo

| | | |
|------|--|----------------|
| 0461 | | 1500 mm - 80kg |
| 0462 | | 1100 mm - 80kg |
| 1 | N.2 Soft damper stoppers N.2 Fermi ammortizzati | |
| 1 | | 2200 mm |
| 2 | | 2600 mm |
| 3 | | 3000 mm |
| 02 | Brushed Anodized Silver / Argento Spazzolato | |
| 13 | Brushed Anodized Dark Brown / E3 Spazzolato | |
| 15 | Brushed Anodized Black / Nero Spazzolato | |
| 17 | Brushed Anodized Nickel / Nichel Spazzolato | |
| 25 | Brushed Anodized Graphite / Grafite Spazzolato | |

Magic2 Vetro

COMPLETE BOX KIT / KIT COMPLETO IN SCATOLA



K Complete kit / Kit completo

| | | |
|------|--|----------------|
| 0041 | | 1100 mm - 80kg |
| 0042 | | 1800 mm - 80kg |
| 1 | Glass thk. / Vetri sp. 8 mm (5/16") | |
| 2 | Glass thk. / Vetri sp. 10 mm (3/8") | |
| 3 | Glass thk. / Vetri sp. 12 mm (1/2") | |
| 02 | Brushed Anodized Silver / Argento Spazzolato | |



Magic2 Mix

COMPLETE BOX KIT / KIT COMPLETO IN SCATOLA

| | | |
|----------|-----------------------------|--|
| K | Complete kit / Kit completo | |
| | . | |
| | 0441 | Magic2 MIX UP |
| | 0442 | Magic2 MIX DOWN |
| | 0443 | Magic2 MIX UP |
| | 0444 | Magic2 MIX DOWN |
| | . | |
| | 1 | 1100 mm → 38-40 mm |
| | 2 | 1800 mm → 38-40 mm |
| | 3 | 1100 mm → 42-44 mm |
| | 4 | 1800 mm → 42-44 mm |
| | . | |
| | 02 | Brushed Anodized Silver / Argento Spazzolato |
| | 15 | Brushed Anodized Black / Nero Spazzolato |

Magic2 Uni

COMPLETE BOX KIT / KIT COMPLETO IN SCATOLA



| | | |
|----------|-----------------------------|--|
| K | Complete kit / Kit completo | |
| | . | |
| | 0451 | 40 mm - 30 kg |
| | 0452 | 44 mm - 30 kg |
| | 0453 | 40 mm - 80 kg |
| | 0454 | 44 mm - 80 kg |
| | . | |
| | 1 | 1100 mm |
| | 2 | 1800 mm |
| | . | |
| | 02 | Brushed Anodized Silver / Argento Spazzolato |
| | 15 | Brushed Anodized Black / Nero Spazzolato |

EXAMPLE / ESEMPIO

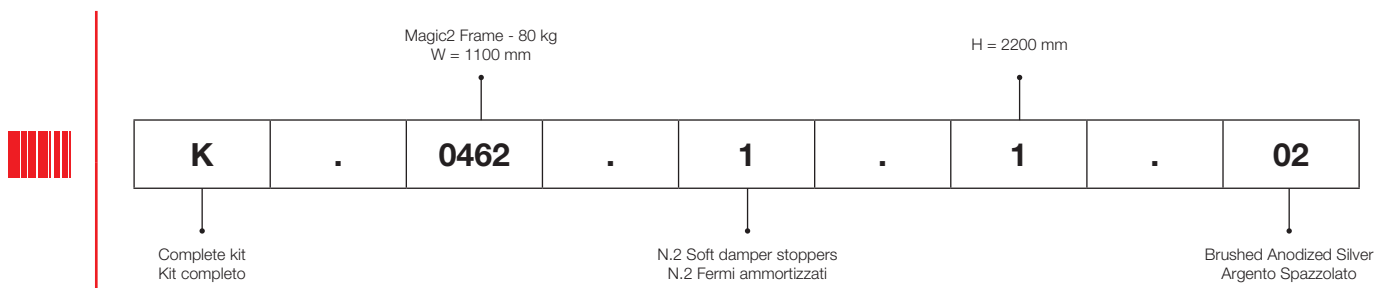

More than 50mm of damping motion

Magic2 system integrates new **PATENTED** dampers with 50 mm of braking motion, 20 mm longer than previous version of **Magic**, while keeping the same door dimensions.

Oltre 50 mm di frenatura

Il sistema **Magic2** integra nuovi fermi ammortizzati **BREVETTATI**, per una frenatura di oltre 50 mm, più di 20 mm rispetto al fermo del modello **Magic**, mantenendo gli stessi ingombri della porta.

PATENTED

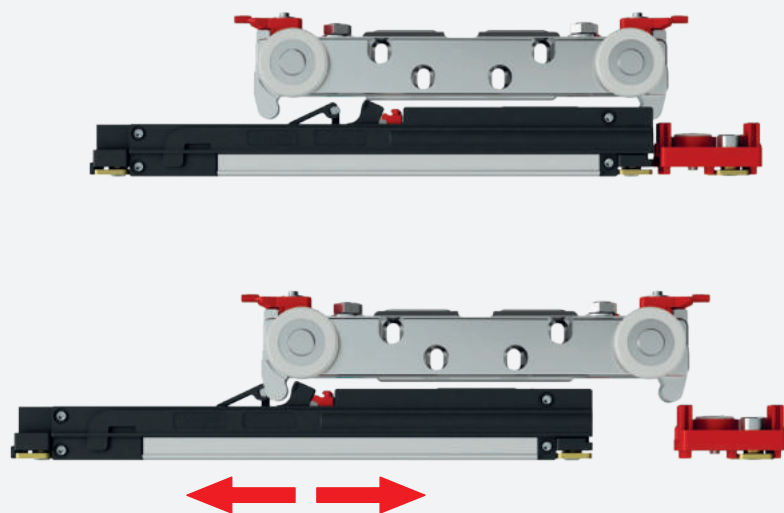
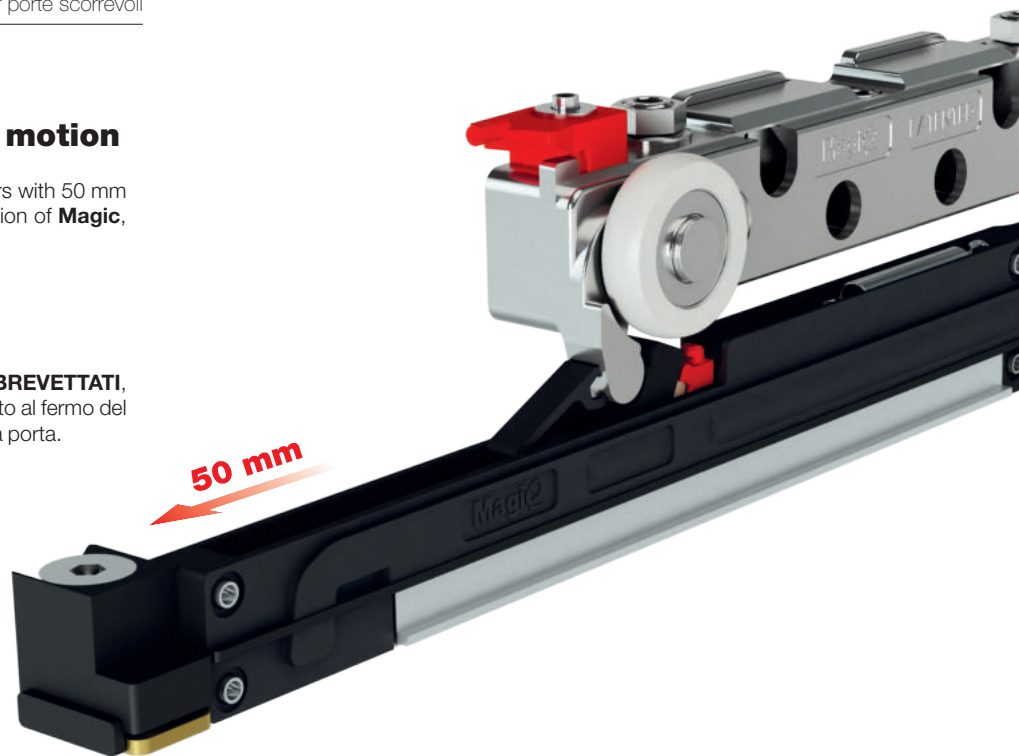

New dampers with adjustable positioning

New **Magic2** adjustable dampers were designed to be independent from wall-spacer wheels. New dampers are suitable to be moved into the track to allow door positioning adjustment.

Nuovi fermi con posizione regolabile

I nuovi fermi del **Magic2** sono stati progettati per essere indipendenti dal distanziale. All'occorrenza si possono spostare per regolare la posizione della porta.

New position of wall-spacer wheels

In **Magic2** system wall-spacer wheels are positioned on the door extremities. The wall-spacer wheels are so positioned in order to protect the door from wall contact, when wall surface are not plane.

Nuova posizione per le ruote distanziali

Nel sistema **Magic2** le ruote distanziali sono posizionate alle estremità della porta. Le ruote distanziali così posizionate proteggono la porta da contatti con la parete, in caso di muri con superfici irregolari.



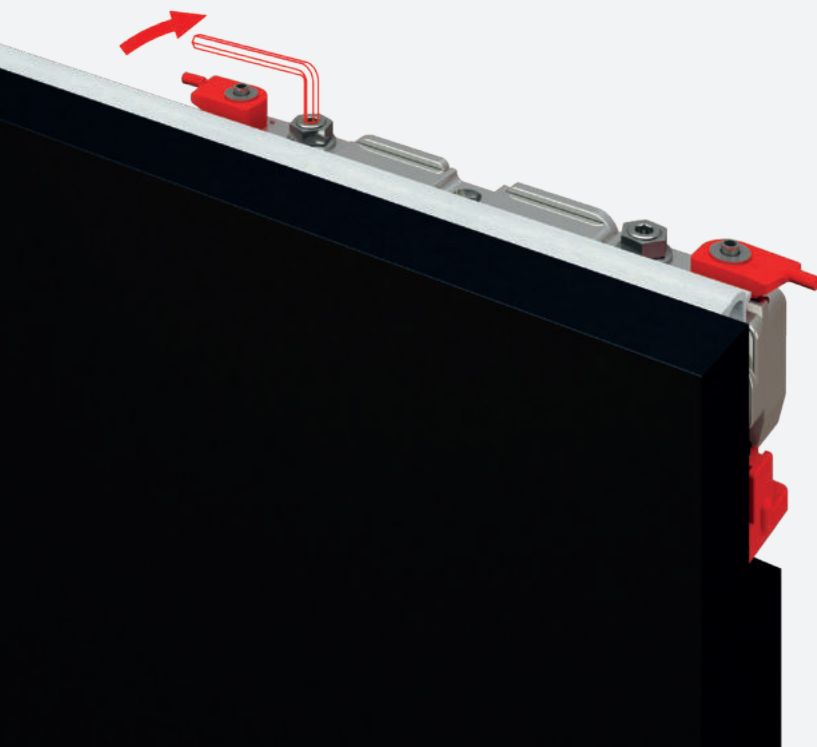

New patented adjustment system

New **Magic² PATENTED** sliding trolley integrates following door adjustments:

- Door height adjustment from floor
- Micrometric adjustment of door from wall
- Micrometric adjustment of door parallelism from wall

Door adjustments of wall distance and parallelism, are meant to compensate possible irregularities of wall. All adjustments are available in the top of sliding trolley, without removing the door.

Nuovo sistema brevettato di regolazione

Il nuovo scorrevole **Magic² BREVETTATO** integra le seguenti regolazioni:

- Regolazione dell'altezza della porta dal pavimento
- Regolazione micrometrica della distanza della porta dalla parete
- Regolazione micrometrica del parallelismo della porta rispetto alla parete

Le regolazioni di distanza e parallelismo della porta, si utilizzano per compensare eventuali irregolarità della parete. Tutte le regolazioni si realizzano dalla parte superiore dello scorrevole, senza sganciare la porta.

Practical anti-jumping system

Magic² sliding trolley includes two new turning anti-jumping activation elements. Turning anti-jumping activation elements are equipped with two safety levers, easy to rotate with no tools required. Safety levers, clearly visible, will have to be removed once anti-jumping system is activated in order to insert end caps.

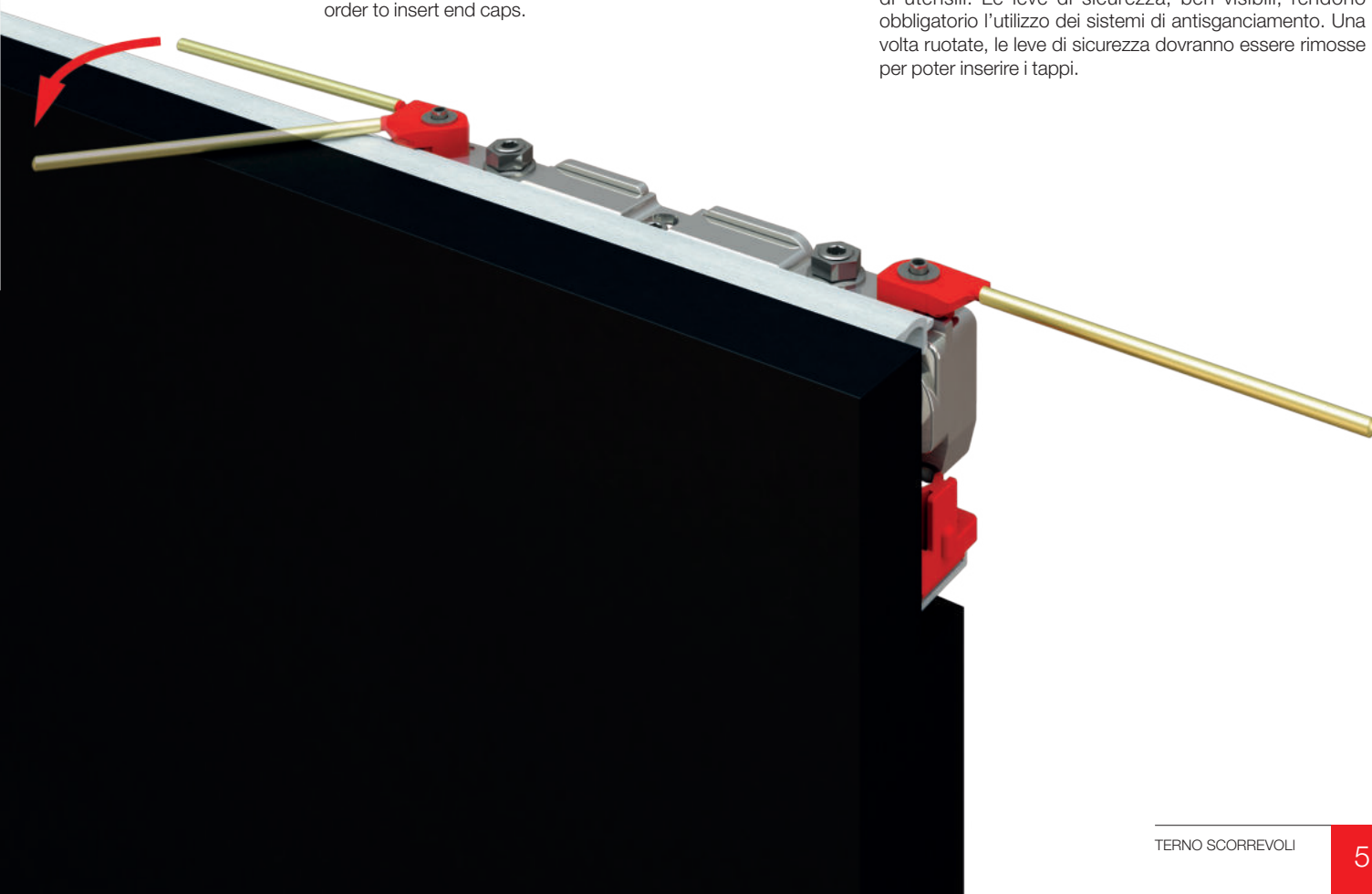

Pratico sistema di antisganciamento

Lo scorrevole **Magic²** comprende due nuovi elementi rotanti di antisganciamento. In questi nuovi elementi sono inserite due leve di sicurezza, per ruotarli senza l'utilizzo di utensili. Le leve di sicurezza, ben visibili, rendono obbligatorio l'utilizzo dei sistemi di antisganciamento. Una volta ruotate, le leve di sicurezza dovranno essere rimosse per poter inserire i tappi.



Silent lower guide

With the purpose of further increase sliding quality, **Magic2** system combines a reinforced lower guide in Zamak (reliable and versatile), which slides in a silent plastic profile.

Guida inferiore silenziosa

Per migliorare ancor di più lo scorrimento, il sistema **Magic2** integra una guida inferiore rinforzata in zama (resistente e versatile), che scorre in un profilo in plastica molto silenzioso.

New patented bottom wheels designed for a better sliding

New **Magic2** bottom wheels are equipped with a **PATENTED** suspension spring system and were designed with a larger diameter, bigger bearing and steel pivots. Rubber surface have been enlarged as well, in order to reinforce wheels and improve sliding quality.

An additional important **PATENTED** innovation in lower sliding system is the introduction of two padded fixed springs which can grant damping function during door motion up to 40kg. Over 40kg of door weight and up to 80kg of maximum load capacity, new bottom wheels will be more flexible than previous version, with their Zamak surface to lean on a rubber internal cylinder, which act as a small shock absorber, granting more stability during sliding motion.

The **Magic2** wheels rubber have high performance:

- it does not leave any trace or sign on sliding surface like floors and walls
- it does not deform over time

Ruote inferiori brevettate per una migliore scorrevolezza

Le nuove ruote inferiori del sistema **Magic2** hanno molleggio **BREVETTATO**, e sono state progettate con diametro, cuscinetti e perni in acciaio maggiorati. Anche il rivestimento in gomma è stato raddoppiato per aumentare la forza e la scorrevolezza delle ruote.

Un'altra importante innovazione **BREVETTATA** nel sistema di scorrimento inferiore è l'inserimento di due molle fisse maggiorate che permettono di ammortizzare il movimento della porta fino ad una portata di 40 kg. Oltre i 40 kg, e fino ad un massimo di 80 kg, queste nuove ruote flettono maggiormente e la superficie realizzata in zama si appoggia su di un cilindro di gomma interno che funge da ammortizzatore supplementare garantendo maggior stabilità.

La gomma delle ruote di **Magic2** è altamente performante:

- non lascia traccia sulle superfici di scorrimento come pavimenti e pareti
- non si deforma nel tempo

KG 0 < KG 40

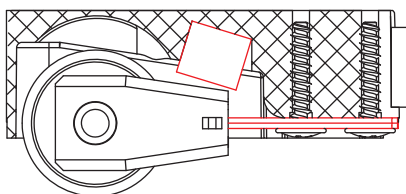

KG 40 < KG 80

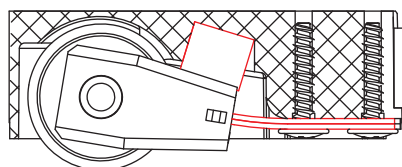

Built-in sliding track with not-through milling

Upper sliding track can be installed "built-in" into a blind milling. Laterally, track's end caps won't be visible, improving even more the aesthetics of door. Door installation and adjustment are not going to be different than usual, because available on the top of the door.

Binario incassato in fresata non passante

Il binario superiore può essere incassato in una fresata cieca. Lateralmente non saranno visibili i tappi del binario, migliorando ulteriormente l'estetica della porta. L'installazione e regolazione della porta non variano perché le regolazioni si effettuano dal lato superiore della porta.

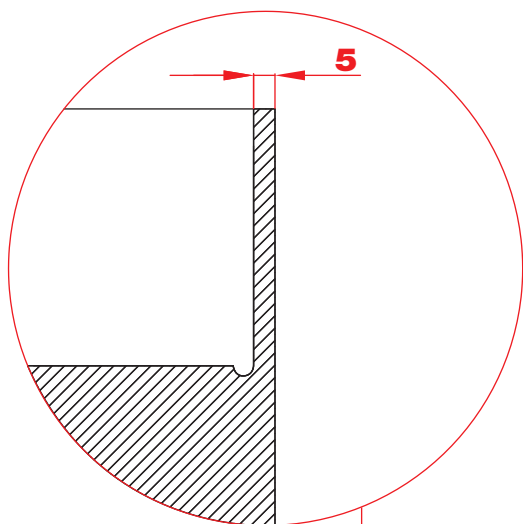

Magic2

VETRO

PATENTED

Magic2 Vetro is the new **PATENTED** and **INVISIBLE** sliding door system outside the wall with soft-closing. The system might be fixed with exposed studs or bundle and it is suitable to monolithic or laminated glasses, from 8 up to 12,7 mm of thickness.

Magic2 Vetro è l'innovativo **SISTEMA INVISIBILE BREVETTATO** per porte scorrevoli in vetro esterno muro con fermi ammortizzati.

Il sistema può essere fissato tramite borchie o fascia a vista ed è adatto per vetri monolitici o stratificati, con spessore da 8 a 12,7 mm.



dressing rooms



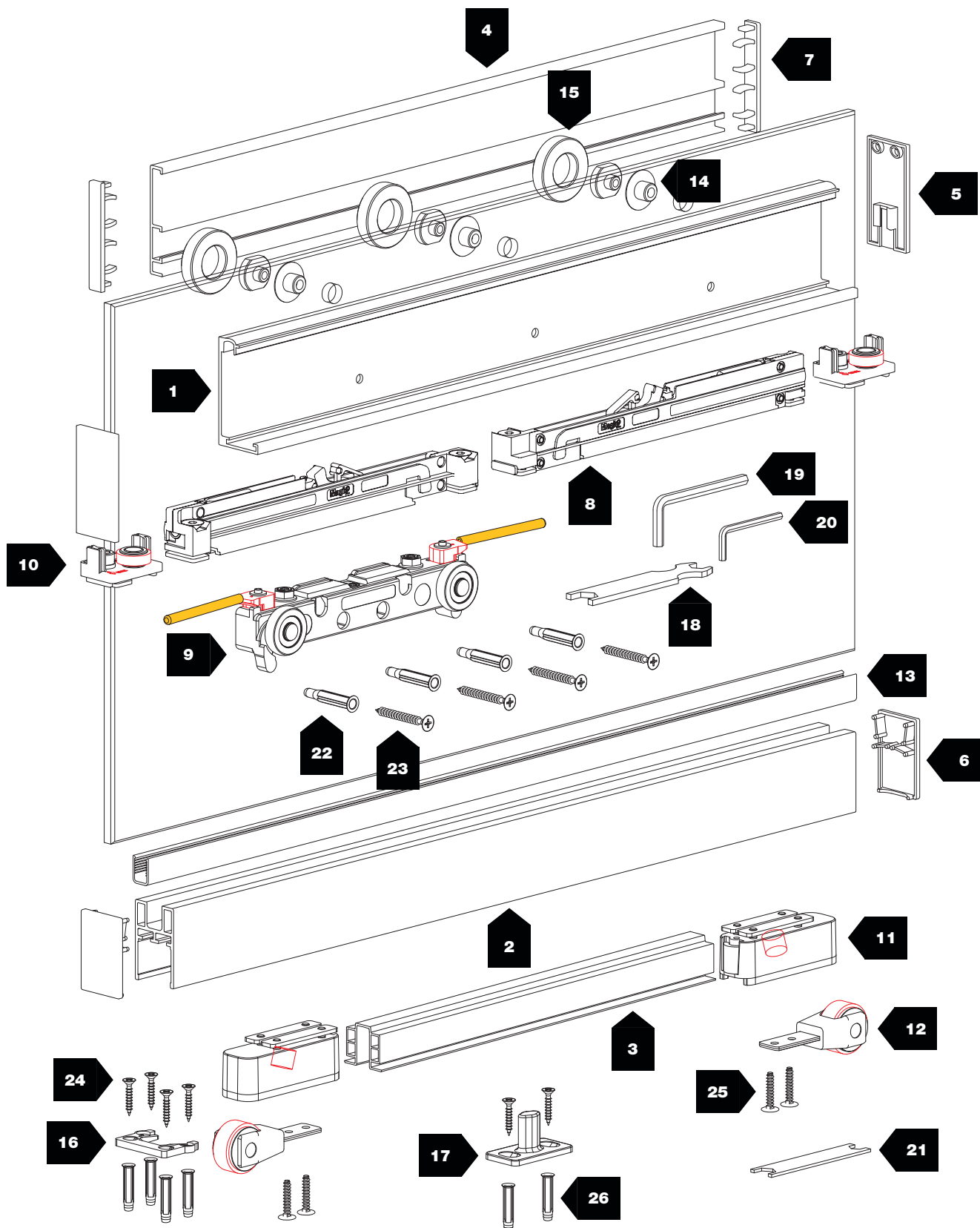











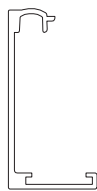
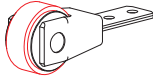

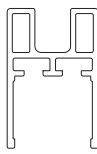



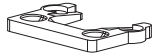

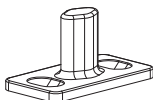
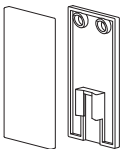
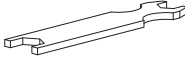
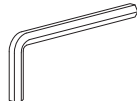
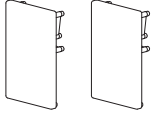
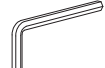
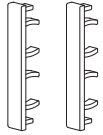

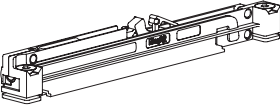
680 ÷ 1800 mm

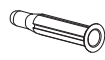
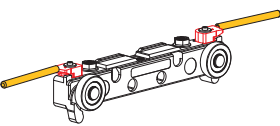

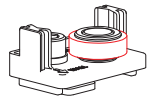
80 kg

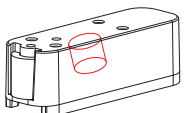

10 mm

| N° | Barcode | | kg | | N° | Barcode | | kg | |
|----|---------|---|----|---|----|-------------|---|----|---|
| 1 | 2850 |  | — | | 12 | 2857 |  | — |  |
| 2 | 2863 |  | — | Glass thk. Vetri sp. 8 mm (5/16") | 13 | 2193 |  | — | |
| | 2862 | | | Glass thk. Vetri sp. 10 mm (3/8") | 14 | 2195 |  | — | |
| | 2861 | | | Glass thk. Vetri sp. 12 mm (1/2") | 15 | 2197/A |  | — | |
| 3 | 2860 |  | — | | 16 | 2859 |  | — | |
| 4 | 2198 |  | — | | 17 | 2855 |  | — | |
| 5 | 2851/N |  | — | | 18 | 1025 |  | — | |
| | 2851/A | | | | 19 | 538 |  | — | |
| 6 | 2866 |  | — | | 20 | 654 |  | — | |
| 7 | 2199 |  | — | | 21 | 1164 |  | — | |
| 8 | 2864-80 |  | 80 |  | 22 | FISCHER UX6 |  | — | |
| 9 | 2852 |  | 80 |  | 23 | 4,5x40 |  | — | |
| 10 | 2856 |  | — |  | 24 | 4x30 |  | — | |
| 11 | 2858 |  | — |  | 25 | 4x20 |  | — | |
| | | | | | 26 | FISCHER SX5 |  | — | |



80 kg



N.2 Soft damper stoppers
N.2 Fermi ammortizzati



Customizable door width
Larghezza porta personalizzabile



Patented system
Sistema brevettato



Brushed Anodized Silver
Argento Spazzolato

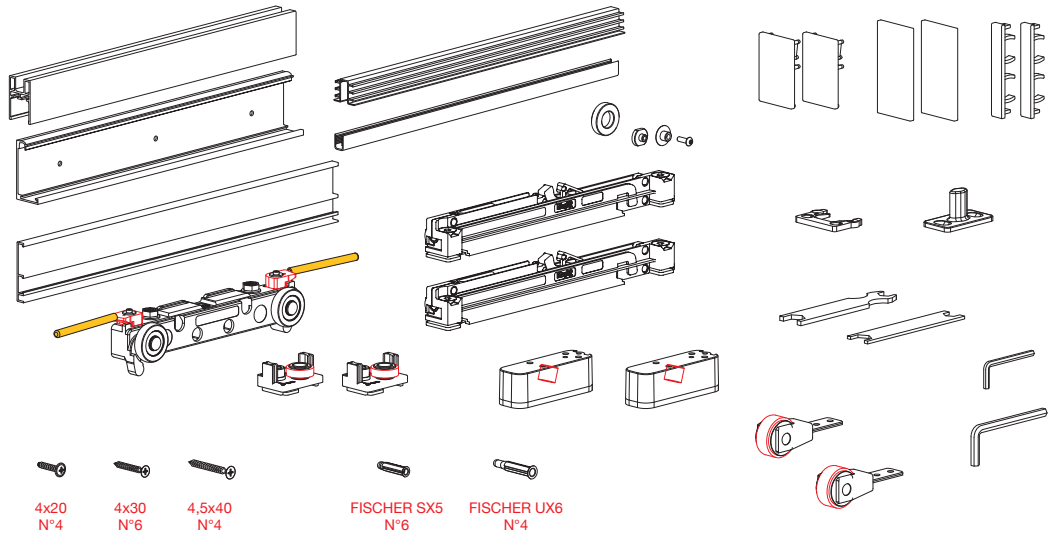

4x20 N°4 4x30 N°6 4,5x40 N°4

FISCHER SX5 N°6 FISCHER UX6 N°4

| OLD CODE | NEW CODE | | | |
|------------------|-------------|--------------|---------|----|
| MAGIC2/1100/V/08 | K.0041.1.02 | 8 mm (5/16") | 1100 mm | 6x |
| MAGIC2/1100/V/10 | K.0041.2.02 | 10 mm (3/8") | | 6x |
| MAGIC2/1100/V/12 | K.0041.3.02 | 12 mm (1/2") | | 6x |
| MAGIC2/1800/V/8 | K.0042.1.02 | 8 mm (5/16") | 1800 mm | 4x |
| MAGIC2/1800/V/10 | K.0042.2.02 | 10 mm (3/8") | | 4x |
| MAGIC2/1800/V/12 | K.0042.3.02 | 12 mm (1/2") | | 4x |

MEASUREMENTS DESCRIPTION / DESCRIZIONE MISURE

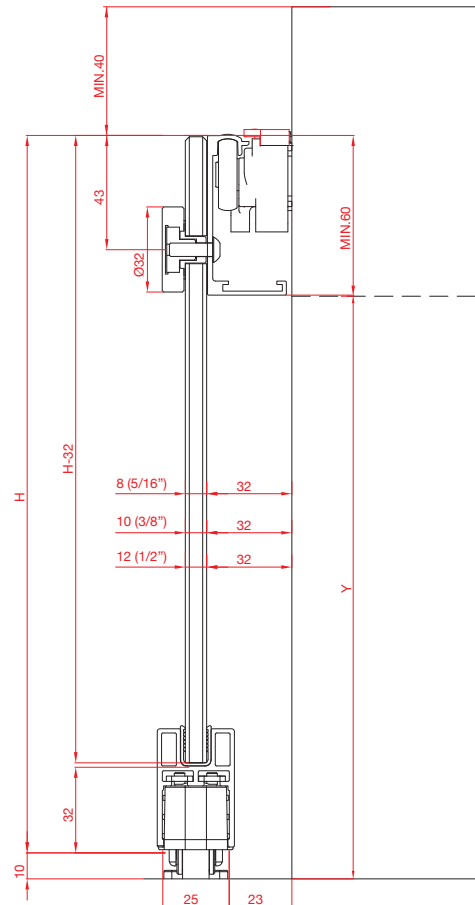
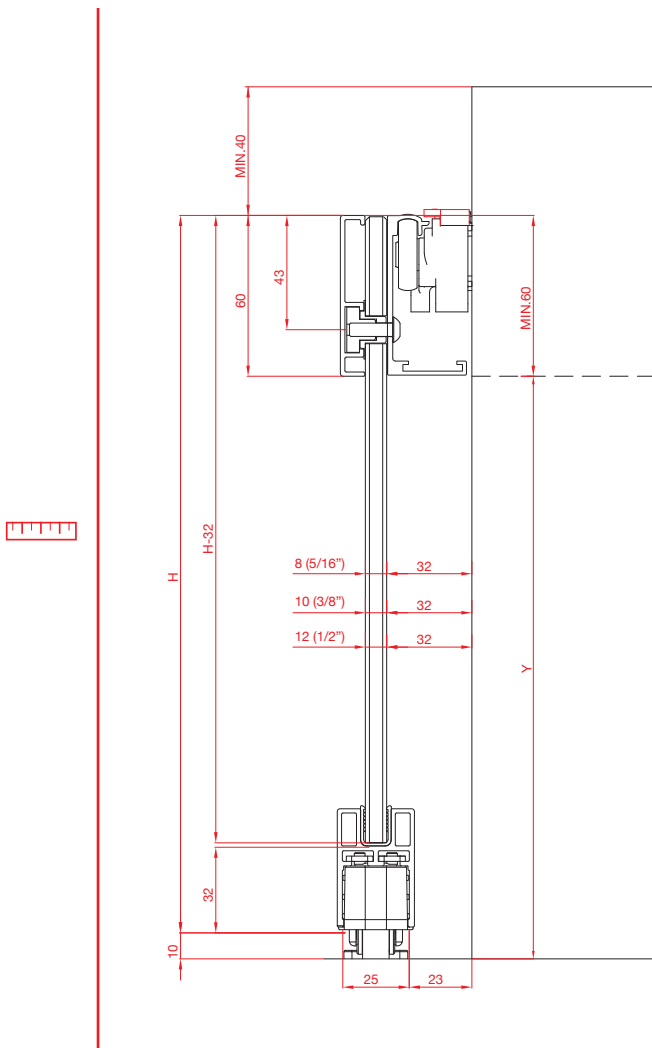

MILLING DESCRIPTION / DESCRIZIONE DELLE LAVORAZIONI

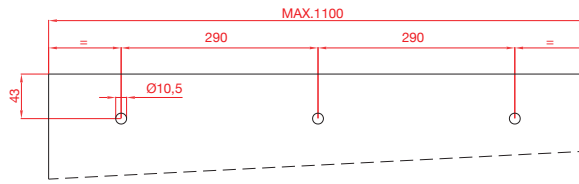

1100 mm

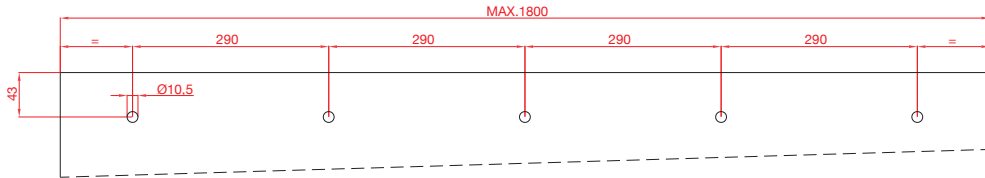

1800 mm

PROFILES CUTTING MEASUREMENTS / MISURE DI TAGLIO DEI PROFILI

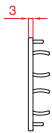
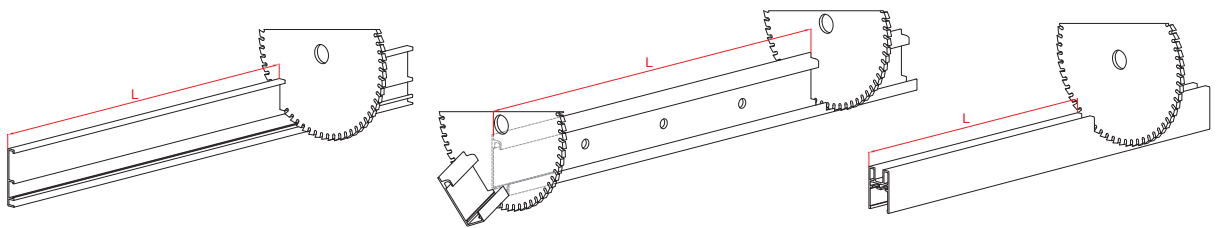

ART. 2199

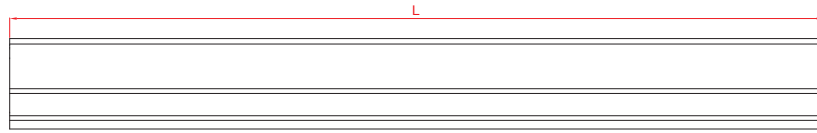

ART. 2198

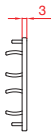

ART. 2199



ART. 2851

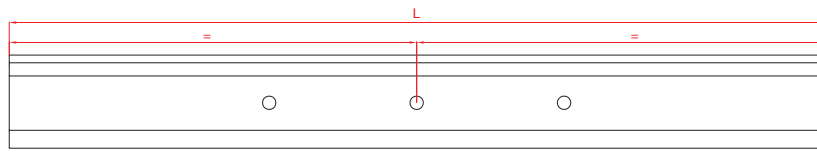

ART. 2850



ART. 2851

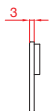

ART. 2866

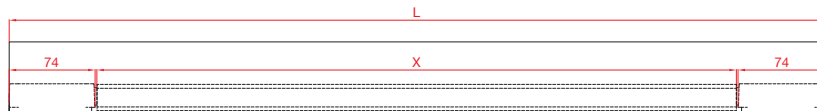

ART. 2863 - ART. 2862 - ART. 2861

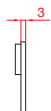

ART. 2866

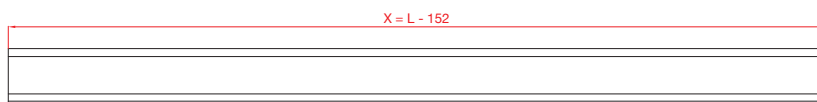

ART. 2860



ACCESSORIES PLACEMENT (STANDARD POSITION) / POSIZIONAMENTO DEGLI ACCESSORI (POSIZIONE STANDARD)

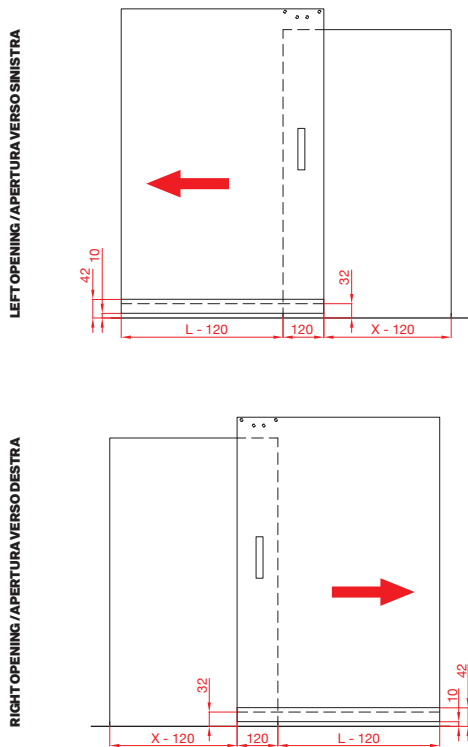

B=0mm (Min.)
B=50mm (Suggested/Suggerito)

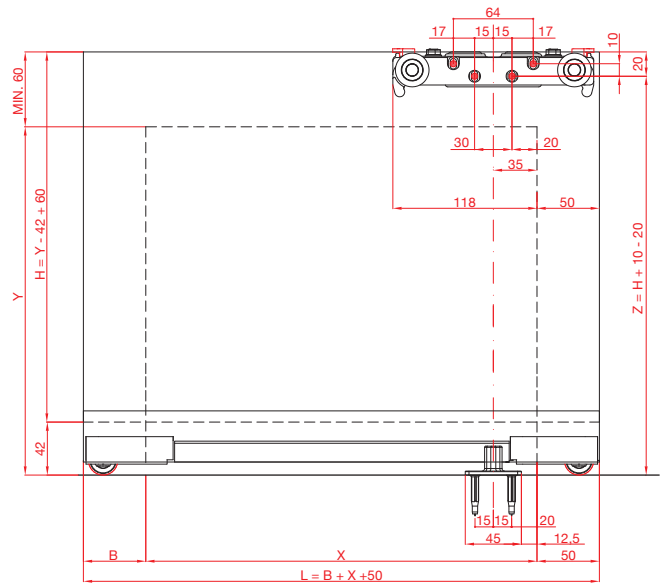

**MAGIC2/1100/V/08 (K.0041.1.02) - MAGIC2/1100/V/10 (K.0041.2.02) -
MAGIC2/1100/V/12 (K.0041.3.02)**

B=0
X= MIN. 800 (L=850)
X= MAX. 1050 (L=1100)

B=50
X= MIN. 800 (L=900)
X= MAX. 1000 (L=1100)

**MAGIC2/1800/V/8 (K.0042.1.02) - MAGIC2/1800/V/10 (K.0042.2.02) -
MAGIC2/1800/V/12 (K.0042.3.02)**

B=0
X= MIN. 800 (L=850)
X= MAX. 1750 (L=1800)

B=50
X= MIN. 800 (L=900)
X= MAX. 1700 (L=1800)

ACCESSORIES PLACEMENT (INTERMEDIATE POSITION) / POSIZIONAMENTO DEGLI ACCESSORI (POSIZIONE INTERMEDIA)

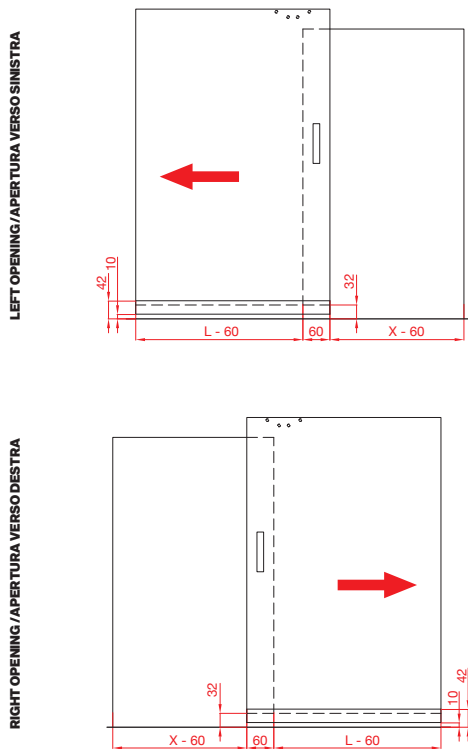

B=0mm (Min.)
B=50mm (Suggested/Suggerito)

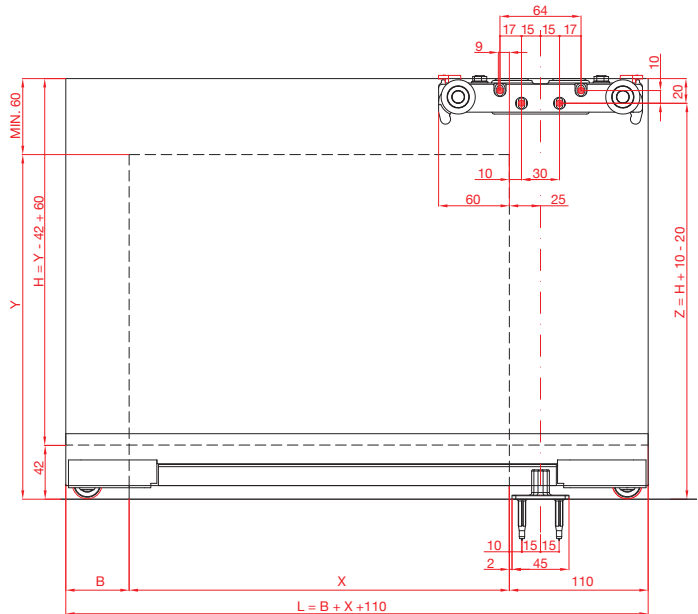

**MAGIC2/1100/V/08 (K.0041.1.02) - MAGIC2/1100/V/10 (K.0041.2.02) -
MAGIC2/1100/V/12 (K.0041.3.02)**

B=0
X= MIN. 740 (L=850)
X= MAX. 990 (L=1100)

B=50
X= MIN. 740 (L=900)
X= MAX. 940 (L=1100)

**MAGIC2/1800/V/8 (K.0042.1.02) - MAGIC2/1800/V/10 (K.0042.2.02) -
MAGIC2/1800/V/12 (K.0042.3.02)**

B=0
X= MIN. 740 (L=850)
X= MAX. 1690 (L=1800)

B=50
X= MIN. 740 (L=900)
X= MAX. 1640 (L=1800)

ACCESSORIES PLACEMENT (TOTAL OPENING POSITION) / POSIZIONAMENTO DEGLI ACCESSORI (POSIZIONE APERTURA TOTALE)

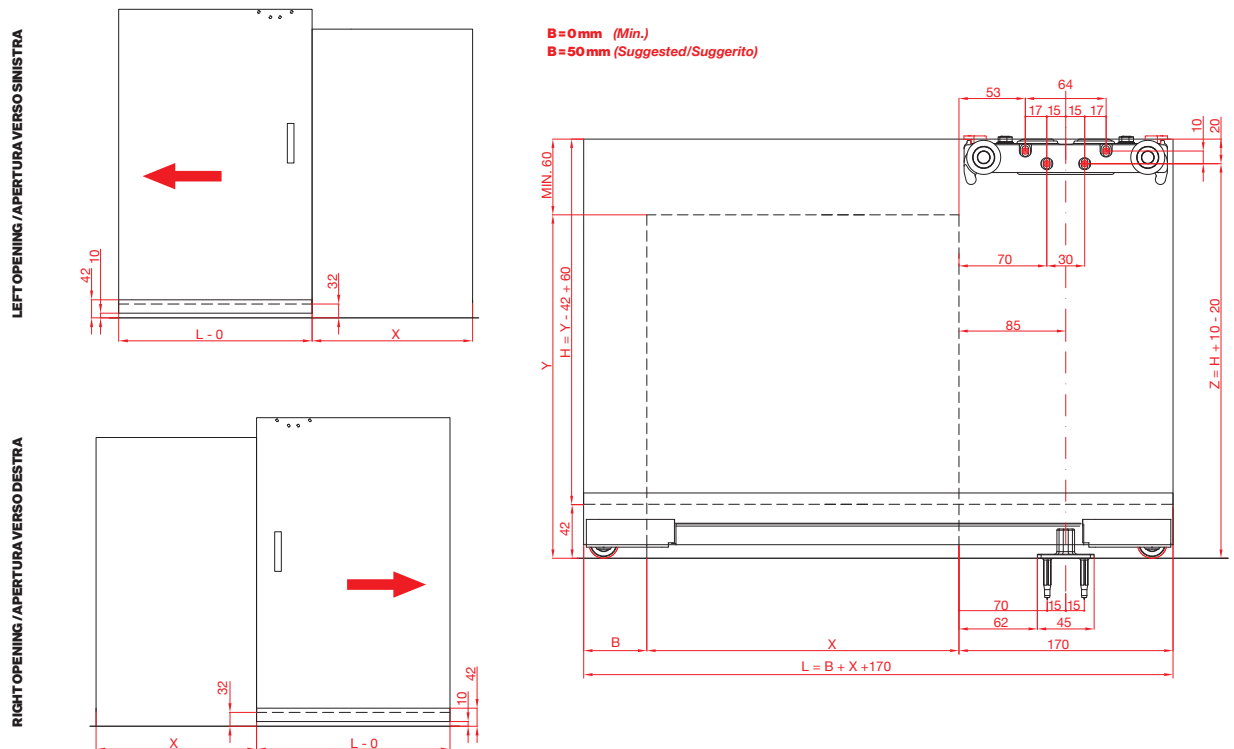

B=0mm (Min.)
B=50mm (Suggested/Suggerito)

**MAGIC2/1100/V/08 (K.0041.1.02) - MAGIC2/1100/V/10 (K.0041.2.02) -
MAGIC2/1100/V/12 (K.0041.3.02)**

B=0
X= MIN. 680 (L=850)
X= MAX. 930 (L=1100)

B=50
X= MIN. 680 (L=900)
X= MAX. 880 (L=1100)

**MAGIC2/1800/V/8 (K.0042.1.02) - MAGIC2/1800/V/10 (K.0042.2.02) -
MAGIC2/1800/V/12 (K.0042.3.02)**

B=0
X= MIN. 680 (L=850)
X= MAX. 1630 (L=1800)

B=50
X= MIN. 680 (L=900)
X= MAX. 1580 (L=1800)

ART. 2859 - END STOPPER / FINE CORSA

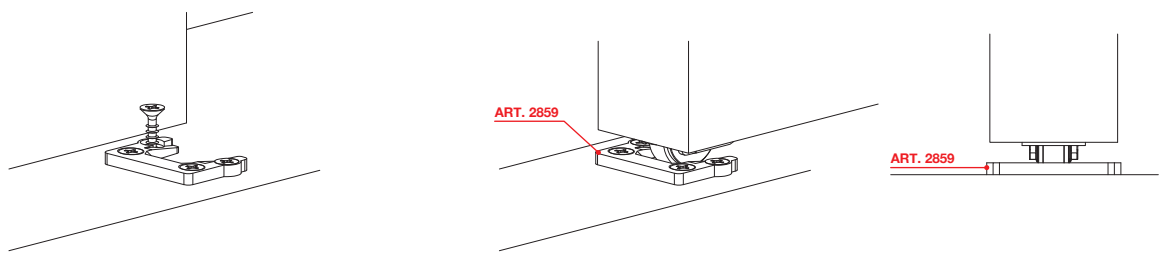

**ALUMINIUM TRACK FOR IRREGULAR FLOOR
PROFILO IN ALLUMINIO PER PAVIMENTAZIONE IRREGOLARE**

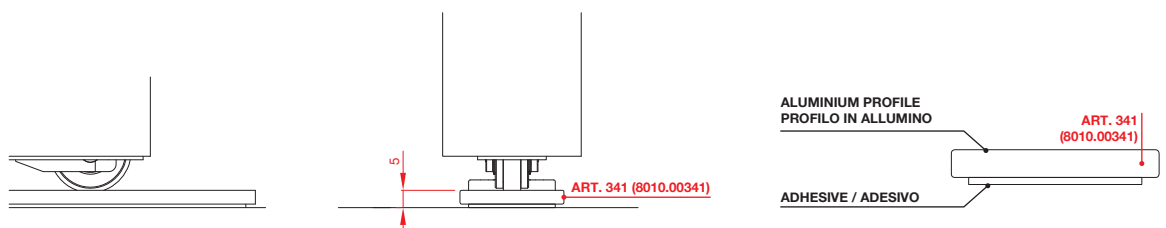

ART. 341
8 01 0 .00341



Micro 50

Concealed sliding elements integrated into profiles with reduced dimensions
Scorrevoli invisibili integrati in profili di scorrimento di dimensioni ridotte

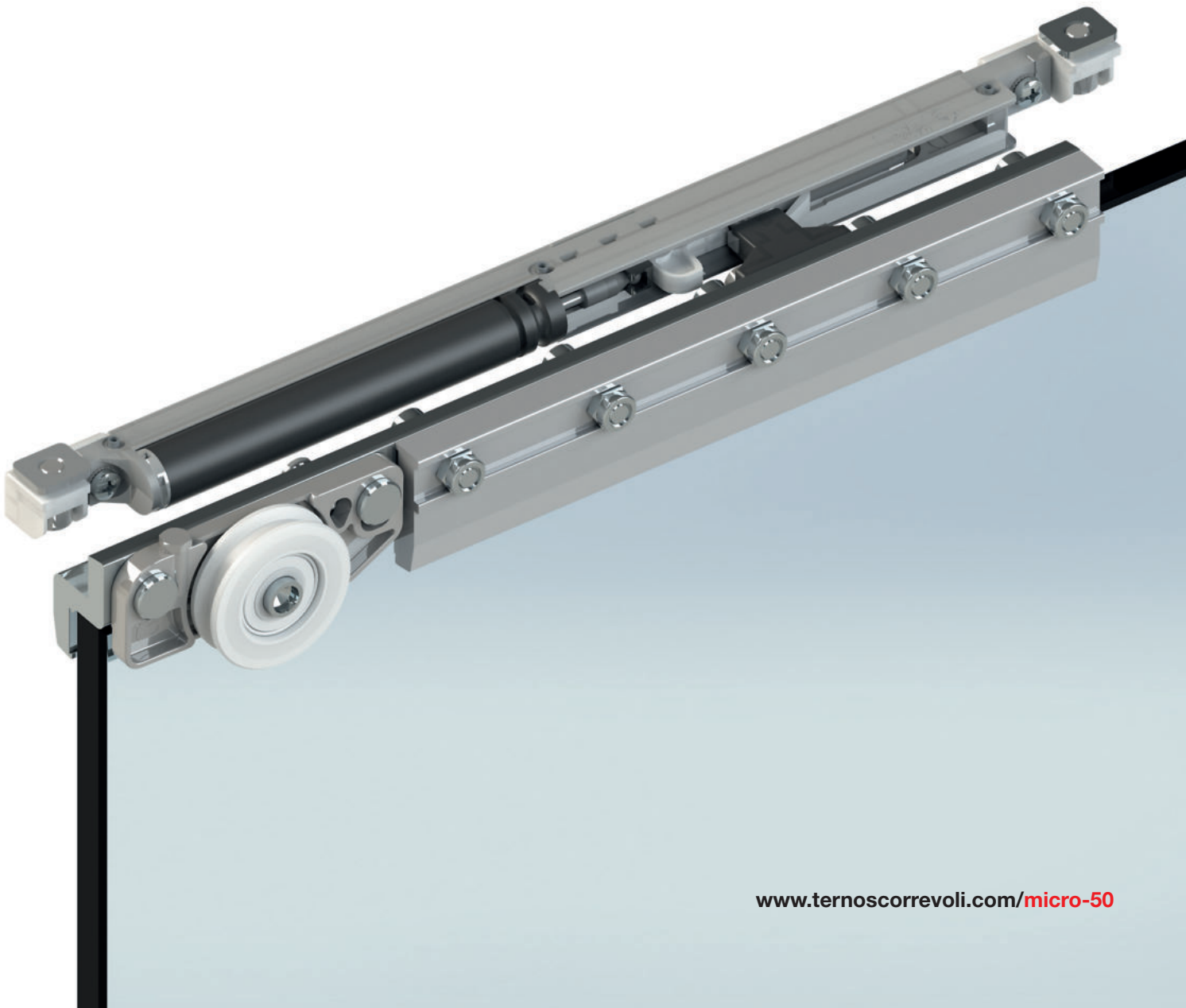



Micro 50

Concealed sliding elements integrated into profiles with reduced dimensions
Scorrevoli invisibili integrati in profili di scorrimento di dimensioni ridotte

Design and functionality

The innovative **Micro 50** system is able to meet current design and load capacity market requirements.

The system, indeed, is equipped with a sliding clamps with totally external adjustment. The sliding clamps, equipped with ball bearings necessary to grant a balanced motion, have been positioned to the door's edges allowing a stable motion even with narrow doors.

Design e funzionalità

L'innovativo sistema **Micro 50** è in grado di soddisfare le esigenze di design e di portata richieste oggi dal mercato.

Il sistema, infatti, monta una ganascia in cui la regolazione è stata completamente spostata all'esterno. I cuscinetti, fondamentali per bilanciare al meglio la porta in vetro, sono stati portati all'estremità: grazie a questa soluzione, il sistema **Micro 50** può essere utilizzato con porte in vetro strette, e si evitano le oscillazioni della porta.

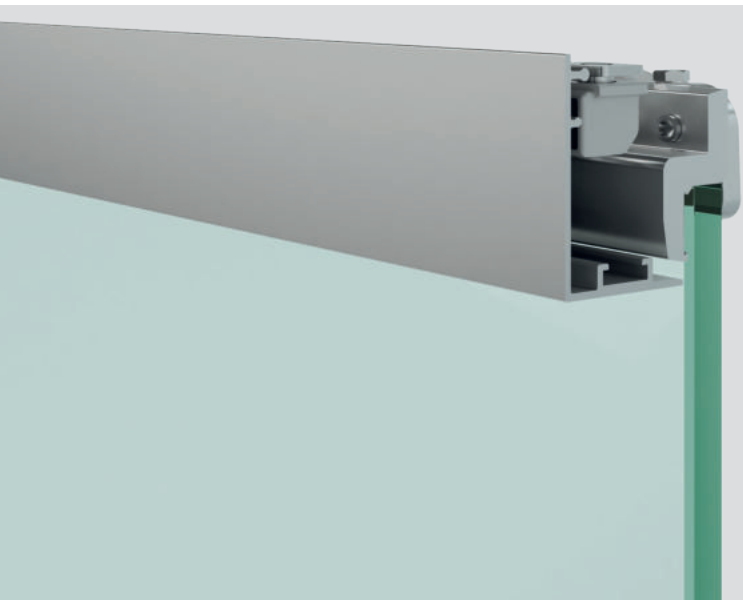
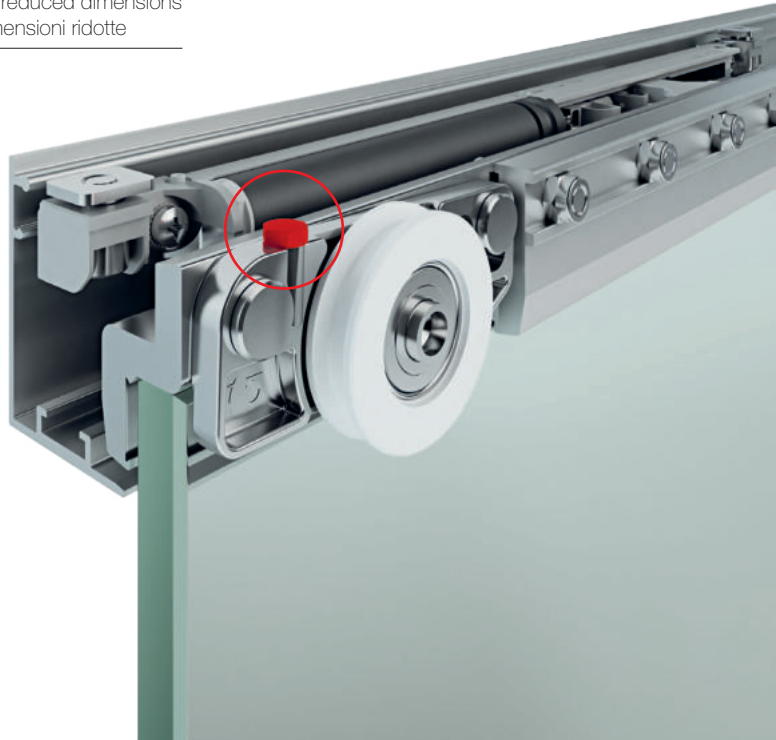

High performances in reduced dimensions

In a space (encumbrance) of **only 50 mm**, the **Micro 50** system integrates bearings able to support a weight of 80 kg. Available both with air-cushioned stops and with standard stops, the system avoids the need of any drilling operations on the glass.

Alte prestazioni in poco spazio

In un ingombro di **solli 50 mm**, il sistema **Micro 50** integra cuscinetti che sostengono un peso di 80 kg. Disponibile sia con fermi ammortizzati ad aria, che con fermi standard, il sistema evita qualsiasi lavorazione di foratura sul vetro.

“Narrow doors, small dimensions, good carrying capacity: Micro 50 is the perfect solution for the market”

“Ante strette, dimensioni ridotte, buona portata: Micro 50 è la soluzione perfetta per il mercato”

An "all around" system

The **Micro 50** system is suitable for both monolithic and laminated glass, since the clamp used is produced in a particular dimension able to avoid any tension on the glass, which could cause it to break.

The **Micro 50** system track is designed to integrate the sliding door with the **fixed glass**.

Un sistema versatile

Il sistema **Micro 50** è adatto sia per vetri monolitici, sia per vetri laminati, poiché la pinza utilizzata è di una dimensione tale da evitare qualsiasi tipo di tensione sul vetro, che potrebbe determinarne la rottura.

Il binario del sistema **Micro 50** è predisposto per integrare la porta scorrevole con il **vetro fisso**.



Micro 50 COMPLETE BOX KIT / KIT COMPLETO IN SCATOLA 

| | | | |
|----------|-----------------------------|---|---|
| K | Complete kit / Kit completo | | |
| | . | | |
| | 0471 |  | Glass thk. / Vetri sp. - 8-8,7 mm (5/16") / 10-10,7 mm (3/8") / 12-12,7 mm (1/2") |
| | | . | |
| | | 4 | N.2 Standard stoppers N.2 Fermi standard |
| | | 5 | N.2 Soft damper stoppers N.2 Fermi ammortizzati |

EXAMPLE / ESEMPIO

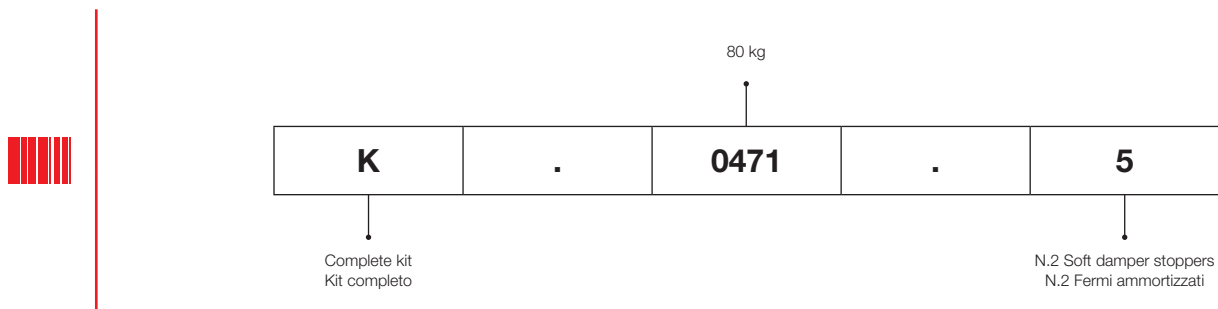

| Tracks / Binari | | ALUMINUM FINISHES CODES / CODICI FINITURE ALLUMINIO | |  |
|------------------------|--|---|--|---|
| CODE / CODICE | | FINISH COLOR / COLORE FINITURA | | |
| 8 01 0.0 |  01 A | Anodized Silver / Argento | | STANDARD |
| 8 02 0.0 |  02 AS | Brushed Anodized Silver / Argento Spazzolato | | |

Micro 50

Concealed sliding elements integrated into profiles with reduced dimensions
Scorrevoli invisibili integrati in profili di scorrimento di dimensioni ridotte

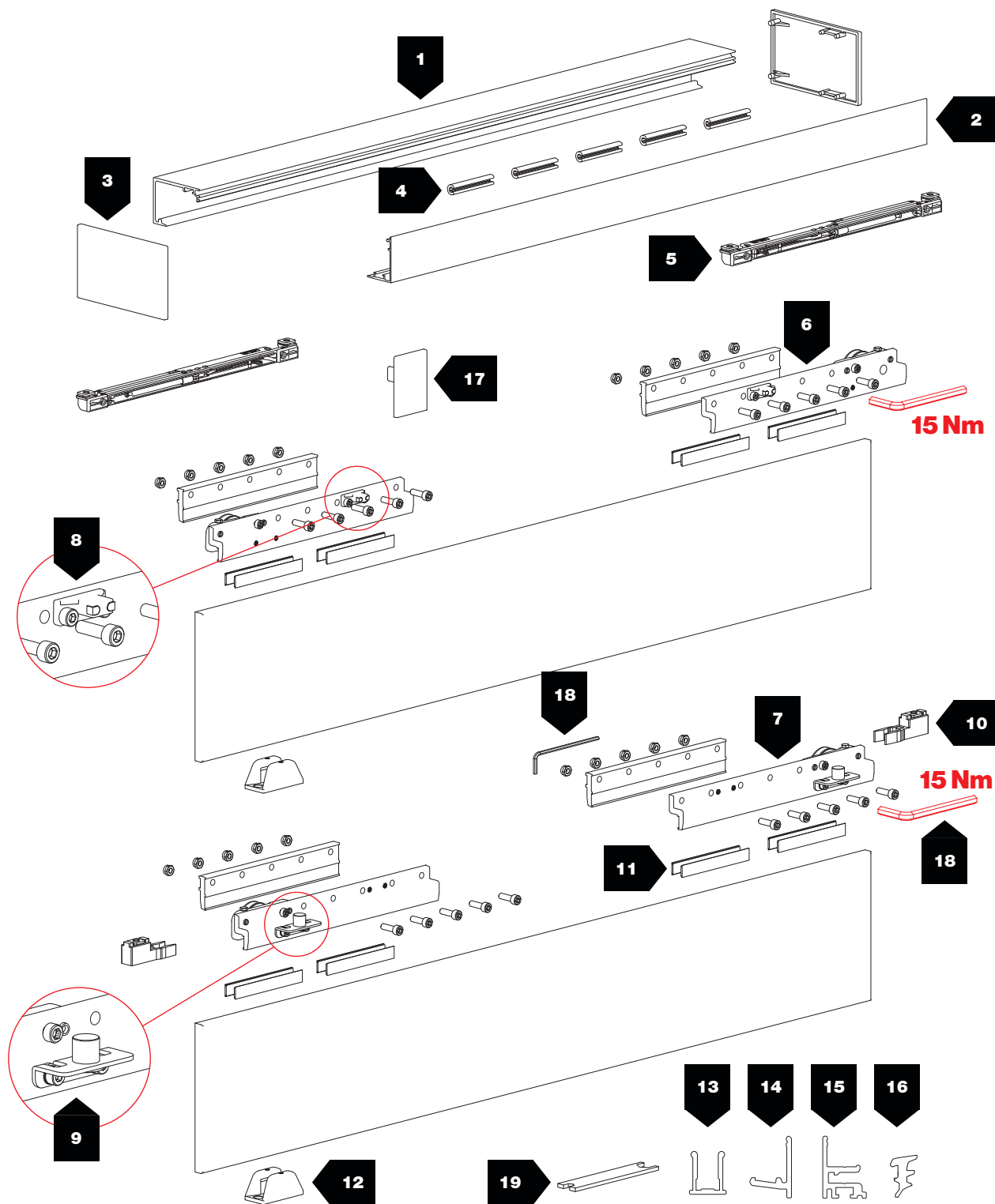

8-8,7 ÷ 12-12,7 mm





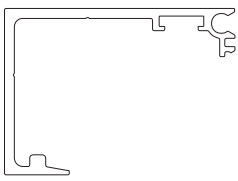
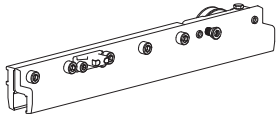
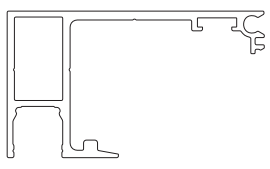
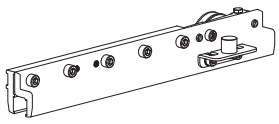
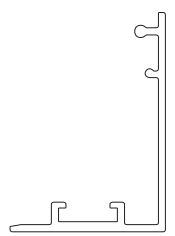
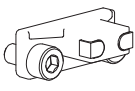
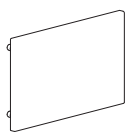
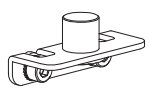
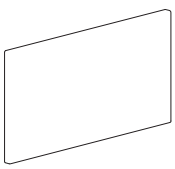
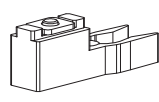
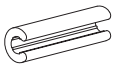
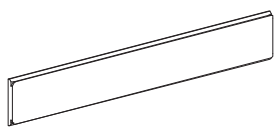
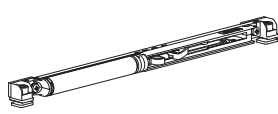
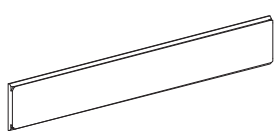



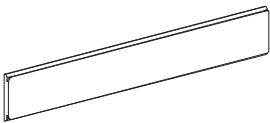

80 kg

| N° | | | kg | | N° | | | kg | |
|----|----------------------|---|----|--|----|------|---|---|---|
| 1 | 2450 8 02 0.02450 |  | — | | 6 | 2454 |  | 80 | |
| | 2460 8 02 0.02460 |  | — | | | 7 | 2444 |  | 80 |
| 2 | 2470 8 02 0.02470 |  | — | | 8 | 2448 |  | 80 | |
| 3 | 2456 |  | — | | 9 | 2459 |  | 80 | |
| | 2466 |  | — | | | 10 | 2458 |  | 80 |
| 4 | 1222 |  | — | | 11 | 1707 |  | — | Glass thk. Vetri sp. 8-8,7 mm (5/16") |
| 5 | 2604 |  | 80 | | | 1704 |  | — | Glass thk. Vetri sp. 10-10,7 mm (3/8") |

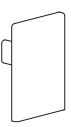
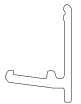
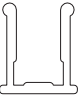
Micro 50

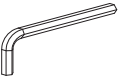
Concealed sliding elements integrated into profiles with reduced dimensions
 Scorrevoli invisibili integrati in profili di scorrimento di dimensioni ridotte

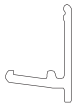
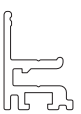
| N° | | | kg | | N° | | | kg | | | | | | | | | | | | | | | | | |
|----|----------------------|---|----|---|-----|---|---|----|--|------|-----|---|---|----|----|------|---|----|---------------|------|---|----|----|------|---|
| 11 | 1705 |  | - | Glass thk. Vetri sp. 12-12,7 mm (1/2") | 328 |  | - | - | Glass thk. Vetri sp. 8-8,7 mm (5/16") | | | | | | | | | | | | | | | | |
| | | | | | | | | | | 1488 | 80 | 326 |  | 80 | 80 | 324 |  | 80 | OPTIONAL + | 1794 |  | 80 | 80 | 1776 |  |
| 12 | 2740 8 02 0.02740 |  | - | - | 16 | 409 |  | - | - | 17 | 538 |  | - | - | 18 | 1029 |  | - | - | | | | | | |
| 13 | 1776 8 01 0.01776 |  | - | - | 19 | | | - | - | | | | | | | | | | | | | | | | |
| 14 | 1775 8 01 2.01775 |  | - | - | | | | - | - | | | | | | | | | | | | | | | | |
| 15 | | | - | - | | | | - | - | | | | | | | | | | | | | | | | |

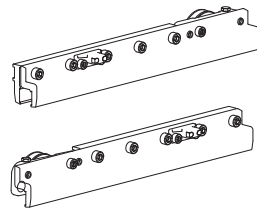
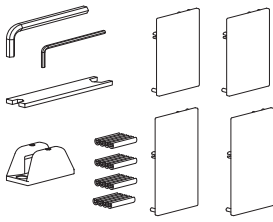

N°8 - ART.1707

N°8 - ART.1704

N°8 - ART.1705

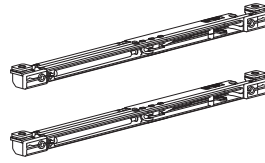

80 kg

N.2 Soft damper stoppers
 N.2 Fermi ammortizzati

| OLD CODE | NEW CODE |  |
|-----------|----------|---|
| 2454/2604 | K.0471.5 | 4x |

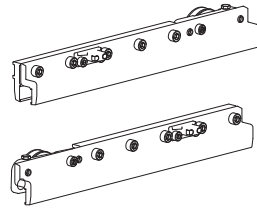
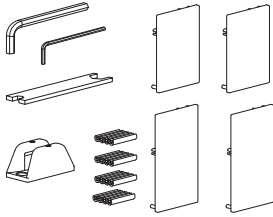

N°8 - ART.1707

N°8 - ART.1704

N°8 - ART.1705



80 kg

N.2 Standard stoppers
 N.2 Fermi standard

| OLD CODE | NEW CODE |  |
|-----------|----------|---|
| 2444/2458 | K.0471.4 | 4x |

MEASUREMENTS DESCRIPTION / DESCRIZIONI MISURE

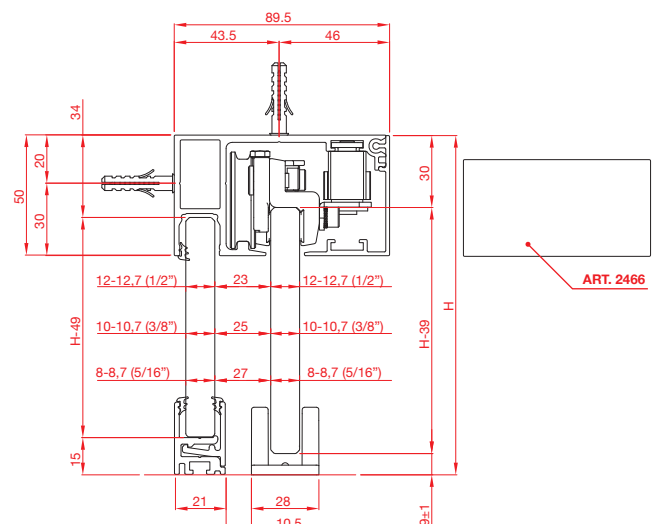
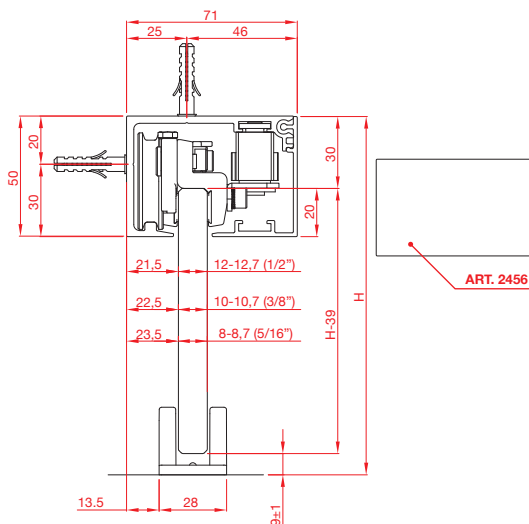
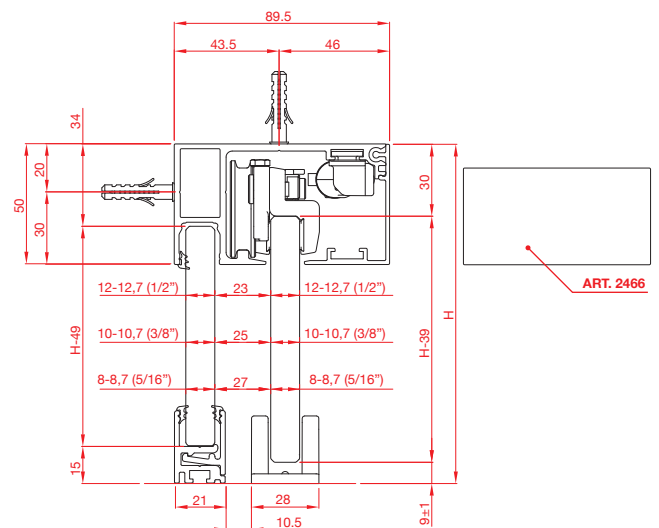
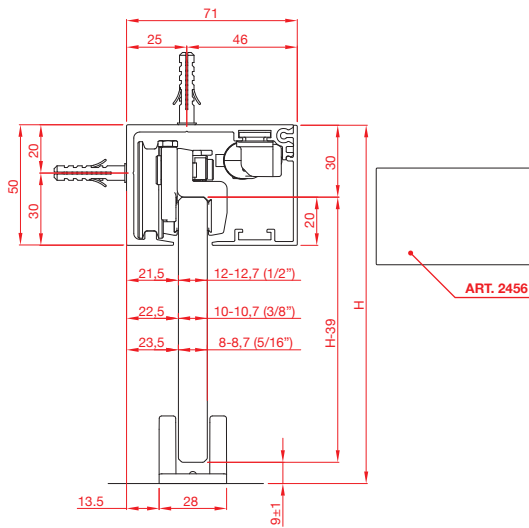



Micro 50 Fix

Concealed sliding elements integrated into profiles with reduced dimensions
Scorrevoli invisibili integrati in profili di scorrimento di dimensioni ridotte





An "all around" system

The **Micro 50 Fix** system is suitable for both monolithic and laminated glass, since the clamp used is produced in a particular dimension able to avoid any tension on the glass, which could cause it to break.

The **Micro 50 Fix** system track is designed to integrate the sliding door with the fixed glass.

Un sistema versatile

Il sistema **Micro 50 Fix** è adatto sia per vetri monolitici, sia per vetri laminati, poiché la pinza utilizzata è di una dimensione tale da evitare qualsiasi tipo di tensione sul vetro, che potrebbe determinarne la rottura. Il binario del sistema **Micro 50 Fix** è progettato per integrare la porta scorrevole con il vetro fisso.



“Narrow doors, small dimensions, good carrying capacity: Micro 50 Fix is the perfect solution for the market”

“Ante strette, dimensioni ridotte, buona portata: Micro 50 Fix è la soluzione perfetta per il mercato”

Design and functionality

The innovative **Micro 50 Fix** system is able to meet current design and load capacity market requirements.

The system, indeed, is equipped with sliding clamps with totally external adjustment. The sliding clamps, equipped with ball bearings necessary to grant a balanced motion, have been positioned to the door's edges allowing a stable motion even with narrow doors.

Design e funzionalità

L'innovativo sistema **Micro 50 Fix** è in grado di soddisfare le esigenze di design e di portata richieste oggi dal mercato.

Il sistema, infatti, monta una ganascia in cui la regolazione è stata completamente spostata all'esterno. I cuscinetti, fondamentali per bilanciare al meglio la porta in vetro, sono stati portati all'estremità: grazie a questa soluzione, il sistema **Micro 50 Fix** può essere utilizzato con porte in vetro strette, e si evitano le oscillazioni della porta.

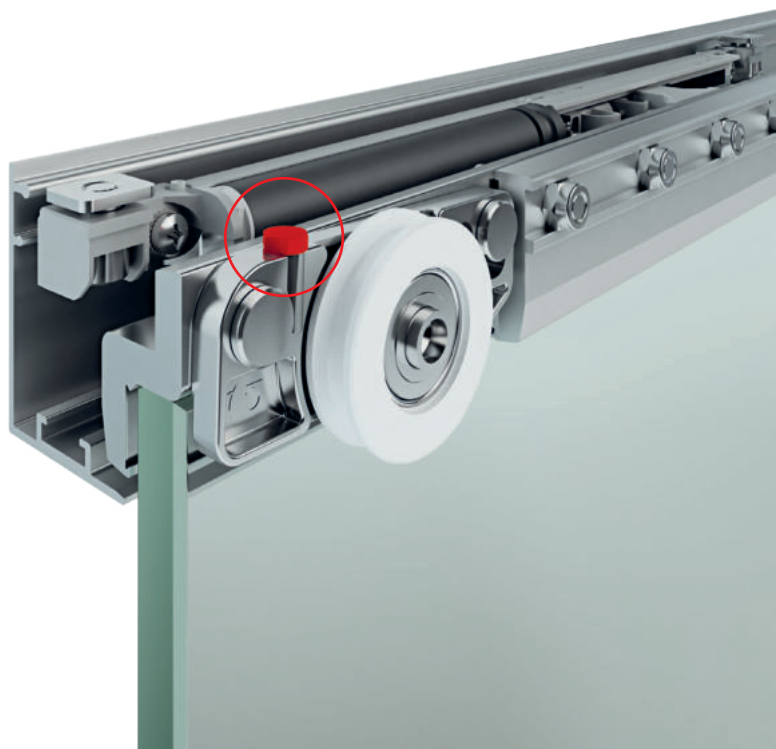



High performances in reduced dimensions

In a space (encumbrance) of **only 50 mm**, the **Micro 50 Fix** system integrates bearings able to support a weight of 80 kg. Available both with air-cushioned stops and with standard stops, the system avoids the need of any drilling operations on the glass.

Alte prestazioni in poco spazio

In un ingombro di **solli 50 mm**, il sistema **Micro 50 Fix** integra cuscinetti che sostengono un peso di 80 kg. Disponibile sia con fermi ammortizzati ad aria, che con fermi standard, il sistema evita qualsiasi lavorazione di foratura sul vetro.

| Micro 50 Fix | | COMPLETE BOX KIT / KIT COMPLETO IN SCATOLA | |  |
|---------------------|-----------------------------|--|--|---|
| K | Complete kit / Kit completo | | | |
| | | 0471 |  Glass thk. / Vetri sp. 8-8,7 mm (5/16") / 10-10,7 mm (3/8") / 12-12,7 mm (1/2") | |
| | | | | |
| | | | 4 | N.2 Standard stoppers N.2 Fermi standard |
| | | | 5 | N.2 Soft damper stoppers N.2 Fermi ammortizzati |

EXAMPLE / ESEMPIO

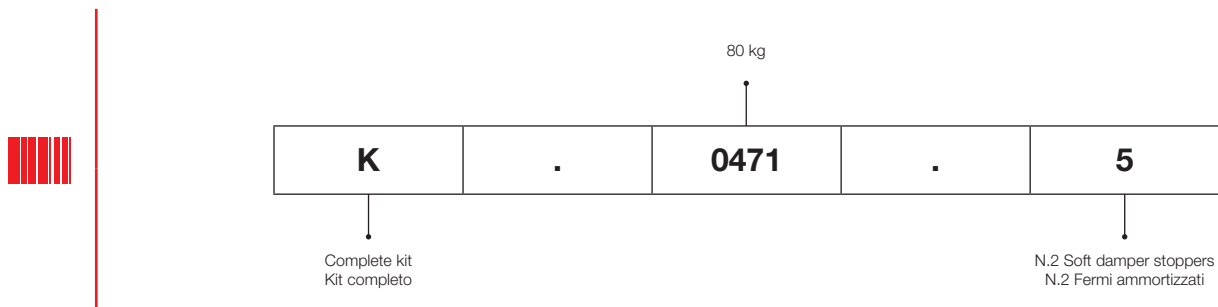

| Tracks / Binari | | ALUMINUM FINISHES CODES / CODICI FINITURE ALLUMINIO | |  |
|------------------------|------------------|---|--------------|---|
| CODE / CODICE | | FINISH COLOR / COLORE FINITURA | | |
| 8 01 | 0.0 |  | 01 A | Anodized Silver / Argento |
| 8 02 | 0.0 |  | 02 AS | Brushed Anodized Silver / Argento Spazzolato |
| | | | | STANDARD |

Micro 50 Fix

Concealed sliding elements integrated into reduced profiles
 Scorrevoli invisibili integrati in profili di scorrimento ridotti

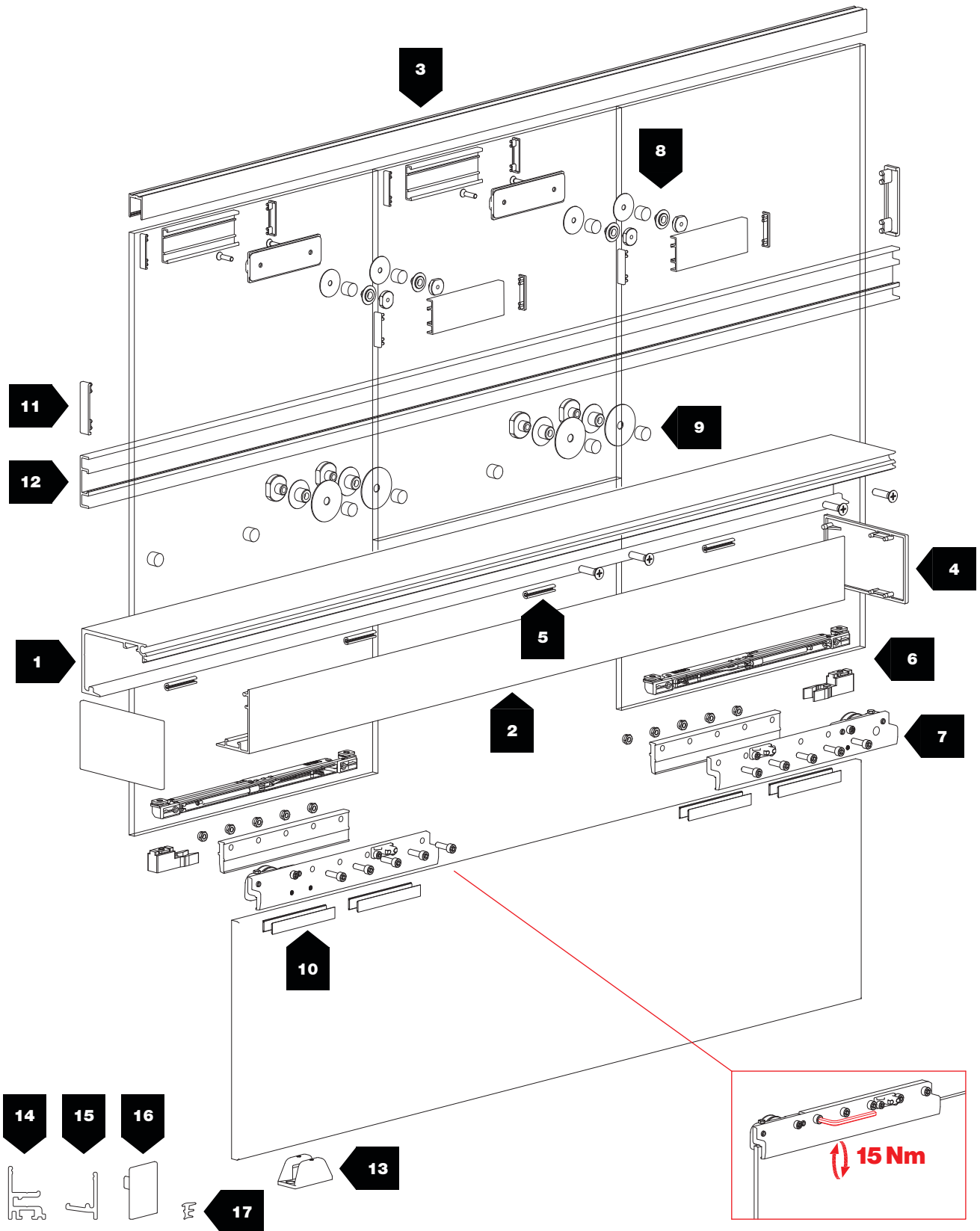

8-8,7 ÷ 12-12,7 mm





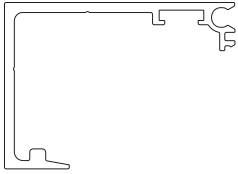
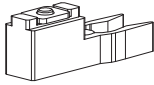
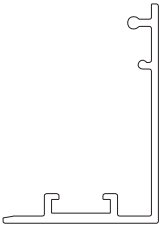
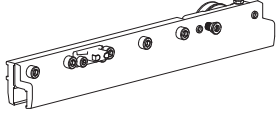
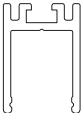
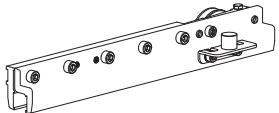
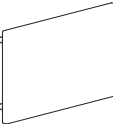
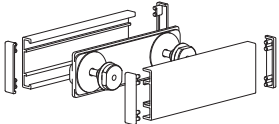
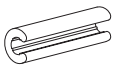
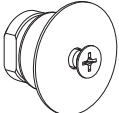
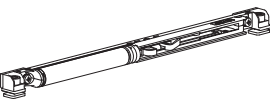
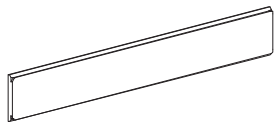

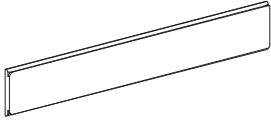
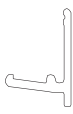
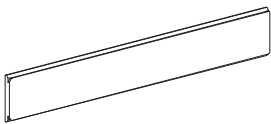
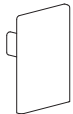
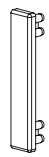

80 kg

| N° | Barcode | | kg | | N° | Barcode | | kg | |
|----|----------------------|---|----|--|----|---------|---|----|--|
| 1 | 2450 8 02 0.02450 |  | — | | 6 | 2458 |  | 80 | |
| 2 | 2470 8 02 0.02470 |  | — | | 7 | 2454 |  | 80 | |
| 3 | 1773 8 01 0.01773 |  | — | | 8 | 2444 |  | 80 | |
| 4 | 2456 |  | — | | 9 | 2608 |  | — | |
| 5 | 1222 |  | — | | 10 | 1707 |  | — | |
| 6 | 2604 |  | 80 | | | |  | — | Glass thk. Vetri sp. 8-8,7 mm (5/16") |

Micro 50 Fix

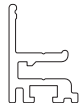
Concealed sliding elements integrated into reduced profiles
Scorrevoli invisibili integrati in profili di scorrimento ridotti

| N° | | | kg | | N° | | | kg | | |
|----|----------------------|---|----|---|----|------|---|---|--|---|
| 10 | 1704 |  | — | Glass thk. Vetri sp. 10-10,7 mm (3/8") | 15 | 1776 |  | — | | |
| | 8 01 0.01776 | | | | | | | | | |
| | 1705 |  | — | Glass thk. Vetri sp. 12-12,7 mm (1/2") | 16 | 1794 |  | — | | |
| | | | | | | | C.1794/A/2 | | | |
| 11 | 2619 C.2619/A/2 |  | — | | 17 | 328 |  | — | Glass thk. Vetri sp. 8-8,7 mm (5/16") | |
| 12 | 2616 8 02 0.02616 |  | — | | | | | | | |
| 13 | 1488 |  | 80 | | | | 326 |  | — | Glass thk. Vetri sp. 10-10,7 mm (3/8") |
| 14 | 1775 8 01 2.01775 |  | — | | | | 324 |  | — | Glass thk. Vetri sp. 12-12,7 mm (1/2") |

Concealed sliding elements integrated into reduced profiles
 Scorrevoli invisibili integrati in profili di scorrimento ridotti

Micro 50 Fix

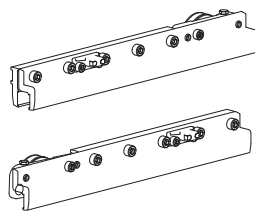
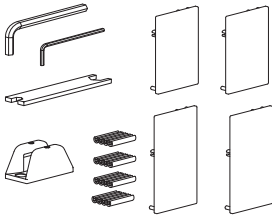

N°8 - ART.1707

N°8 - ART.1704

N°8 - ART.1705

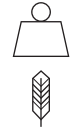
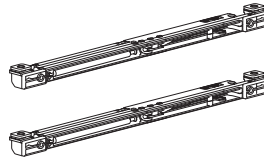
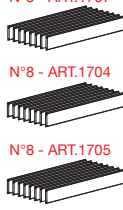

80 kg

N.2 Soft damper stoppers
 N.2 Fermi ammortizzati

| OLD CODE | NEW CODE |  |
|-----------|----------|---|
| 2454/2604 | K.0471.5 | 4x |

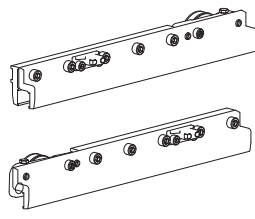
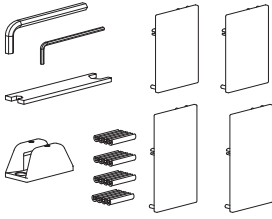

N°8 - ART.1707

N°8 - ART.1704

N°8 - ART.1705

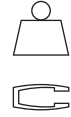
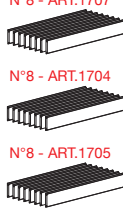

80 kg

N.2 Standard stoppers
 N.2 Fermi standard

| OLD CODE | NEW CODE |  |
|-----------|----------|---|
| 2444/2458 | K.0471.4 | 4x |

MEASUREMENTS DESCRIPTION / DESCRIZIONI MISURE

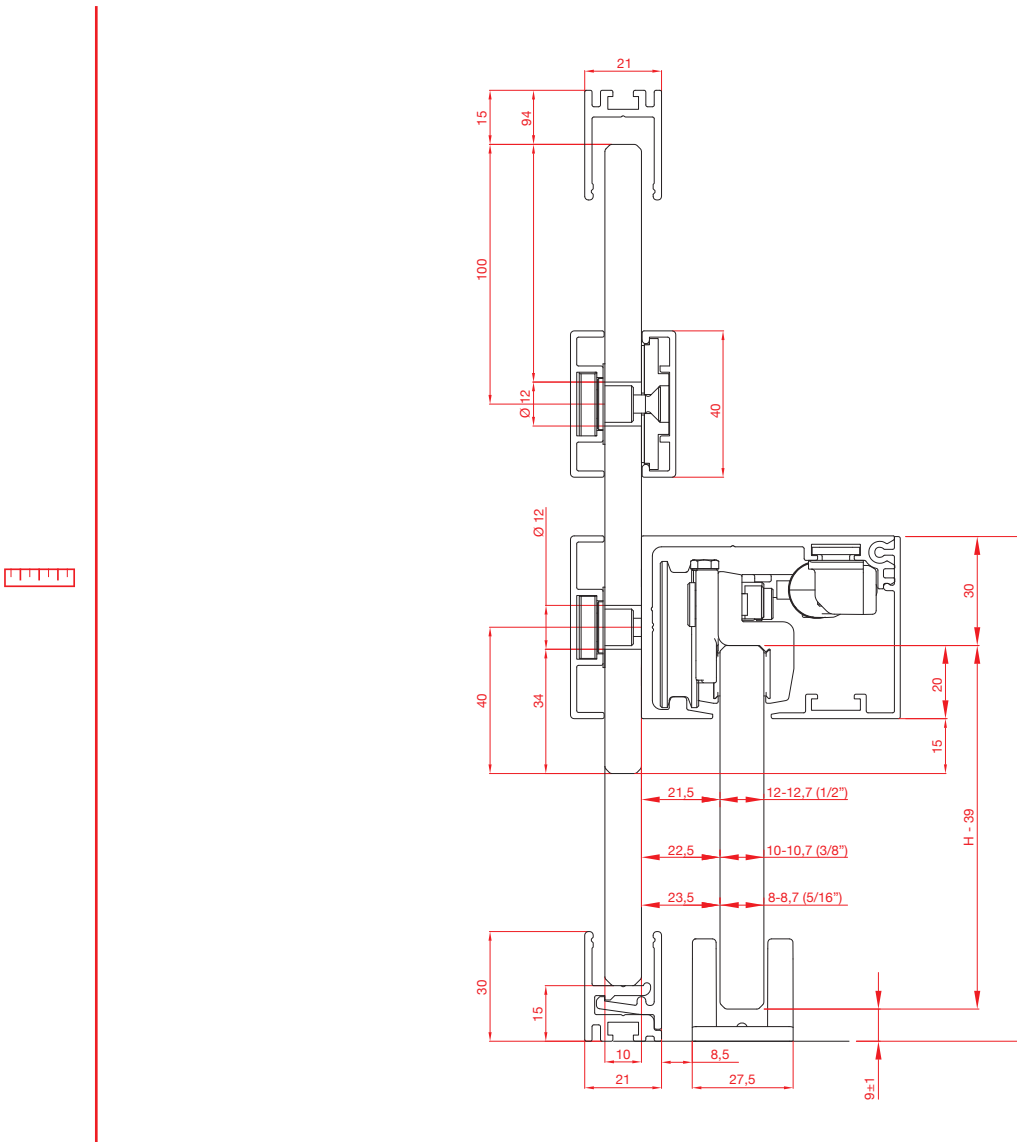

FIXED GLASS MILLING / FRESATURA VETRI FISSI

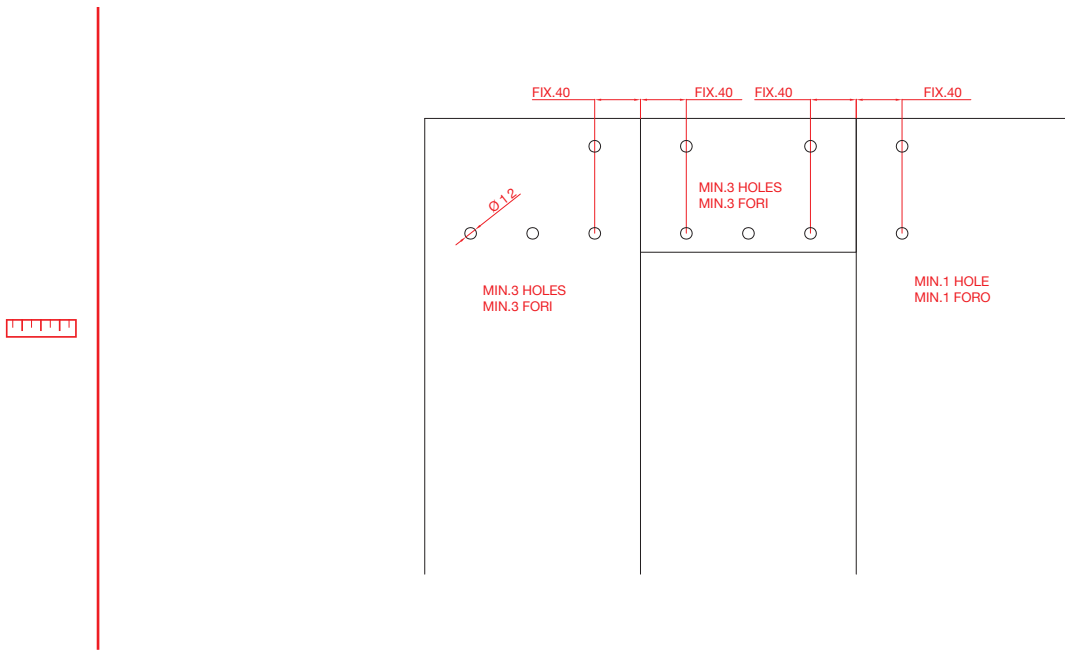

VARIOUS FIXED GLASS COMPOSITIONS ARE IN PREVIOUS PAGES
 LE VARIE COMPOSIZIONI DEI VETRI FISSI SI TROVANO NELLE PAGINE PRECEDENTI

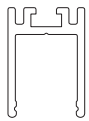

ART. 1773
 8 01 0.01773

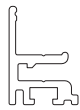

ART. 1775
 8 01 2.01775

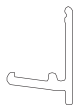

ART. 1776
 8 01 0.01776

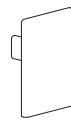

ART. 1794
 C.1794/A/2



ART. 328 - ART. 326 - ART. 324

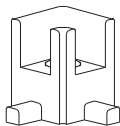

ART. 1777

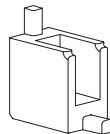

ART. 1779

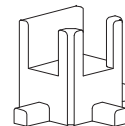

ART. 1778



Plasterboard Cartongesso

Plasterboard tracks and accessories
Binari e accessori per cartongesso

Plasterboard / Cartongesso

Tracks / Binari

ALUMINUM FINISHES CODES / CODICI FINITURE ALLUMINIO

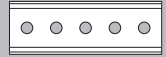

| CODE / CODICE | FINISH COLOR / COLORE FINITURA | | |
|----------------|--------------------------------|---|-------------------------------------|
| 8 00 0.0 | 00 | G | Row - Mill Finish / Neutro - Grezzo |
| | | | STANDARD |

TRACKS AND ACCESSORY FOR PLASTERBOARD / BINARI E ACCESSORI PER CARTONGESSO

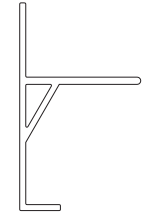

Wall bracket
Sostegno a parete

ART. 2310
8 01 2.02310

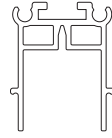

Track bracket
Sostegno binario

ART. 2300
8 00 0.02300
8 01 0.02300

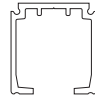

Track
Binario

ART. 1280
8 00 0.01280

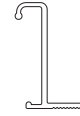

Support plasterboard
Sostegno cartongesso

ART. 2320
8 01 0.02320



Spacer
Distanziale

ART. 2330
8 01 0.02330

ACCESSORIES FOR FULL CEILING FIXTURE ACCESSORI PER FISSAGGIO A SOFFITTO PIENO

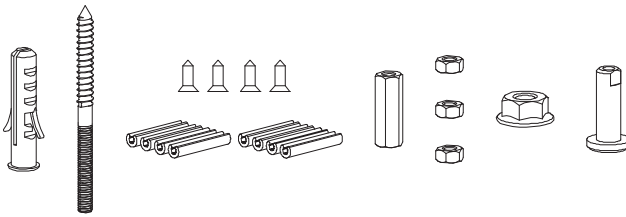

ART. 2304



KIT N° 50 pz.
ART. 2304/50
K.0481.1

ACCESSORIES FOR EMPTY CEILING FIXTURE ACCESSORI PER FISSAGGIO A SOFFITTO VUOTO

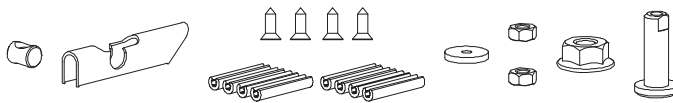

ART. 2306

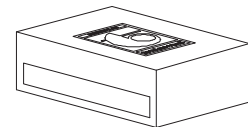

KIT N° 50 pz.
ART. 2306/50
K.0481.2

3 METRE M6 THREADED BAR BARRA FILETTATA M6 DA METRI 3



ART. 2308/3

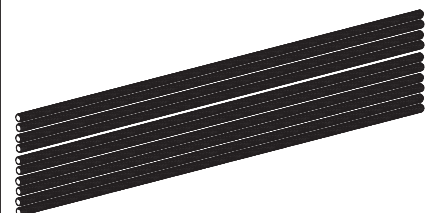

KIT N° 10 pz.
ART. 2308/3/10
K.0402.3

FULL CEILING FIXTURE SYSTEM SISTEMA PER FISSAGGIO SOFFITTO PIENO

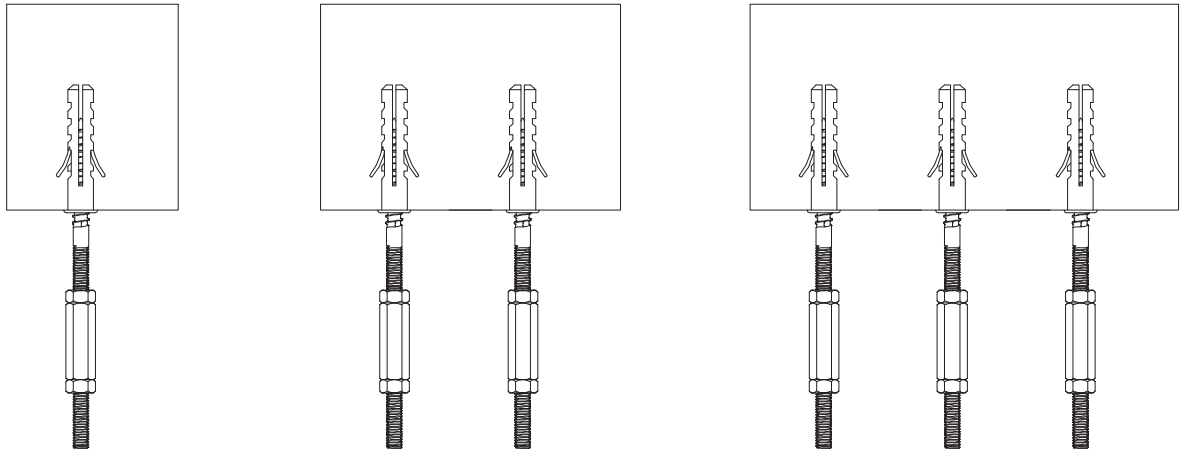

EMPTY CEILING FIXTURE SYSTEM SISTEMA PER FISSAGGIO SOFFITTO VUOTO

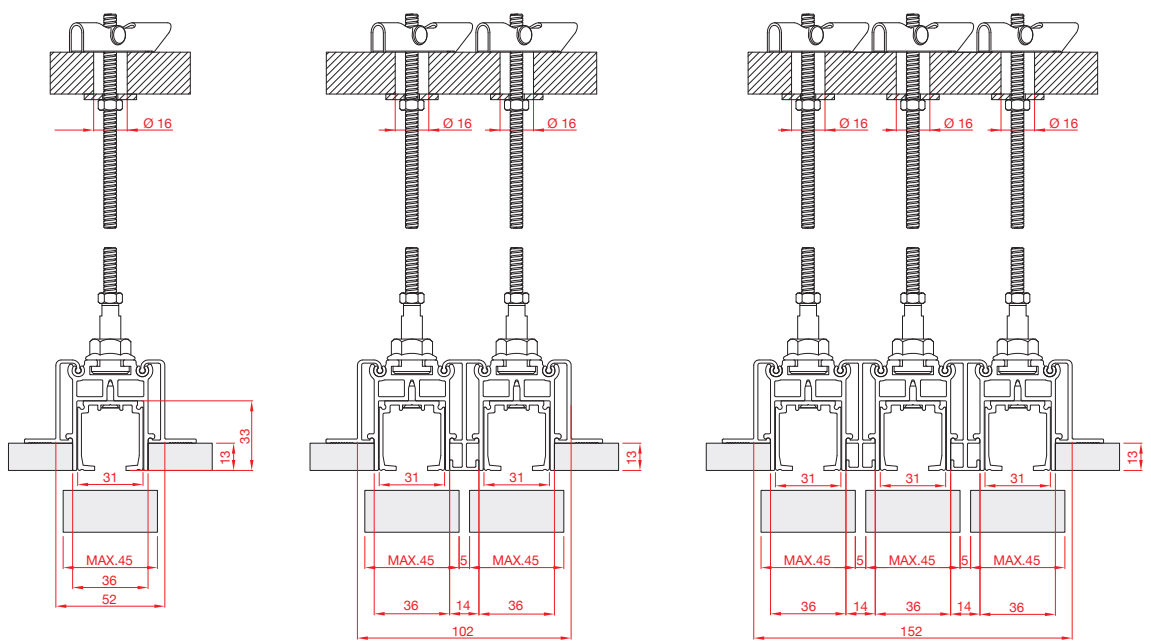

Plasterboard / Cartongesso

WALL-MOUNTING SYSTEM
SISTEMA PER FISSAGGIO A PARETE

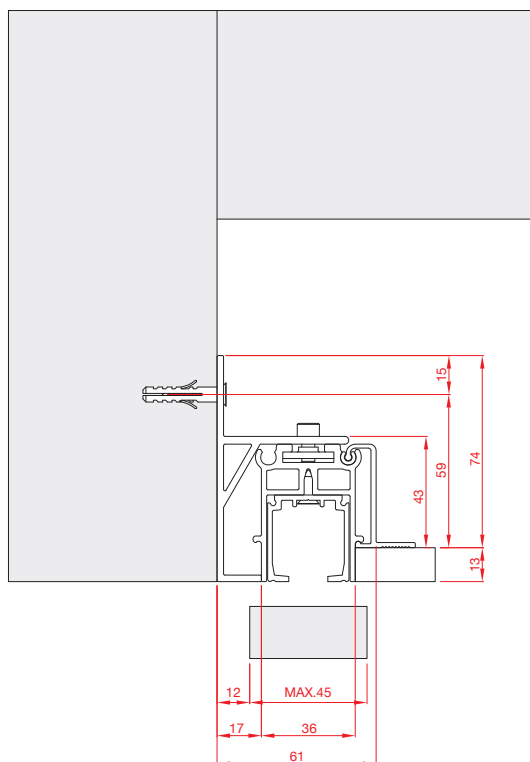

WALL AND CEILING MOUNTING SYSTEM
SISTEMA PER FISSAGGIO A PARETE E SOFFITTO

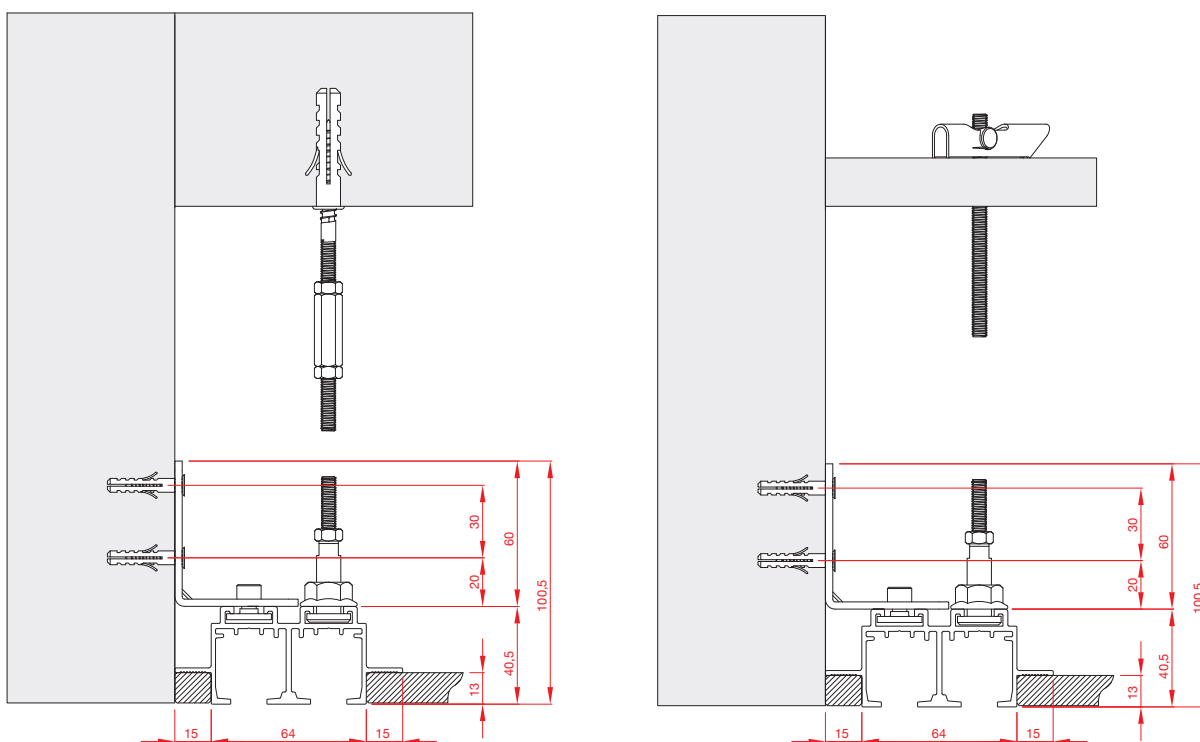

Plasterboard / Cartongesso

TRACKS AND ACCESSORY FOR PLASTERBOARD BINARI E ACCESSORI PER CARTONGESSO

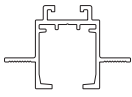

Track / Binario
ART. 1263
8 00 0.01263
8 01 0.01263

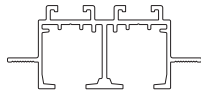

Track / Binario
ART. 1261
8 00 0.01261
8 01 0.01261

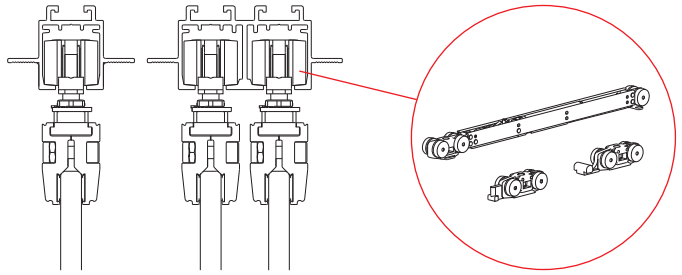

TRACKS USED WITH ALL CARRIAGES AND BRACKETS (40-80 kg)
BINARI UTILIZZABILI CON TUTTI I CARRELLI E STAFFE DA 40-80 kg

WALL-MOUNTING SYSTEM SISTEMA PER FISSAGGIO A PARETE

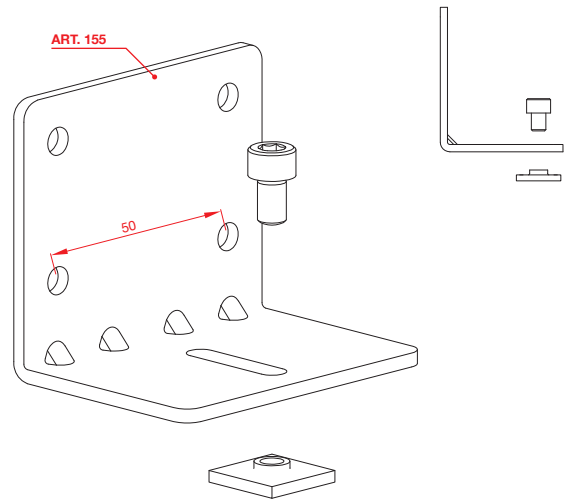
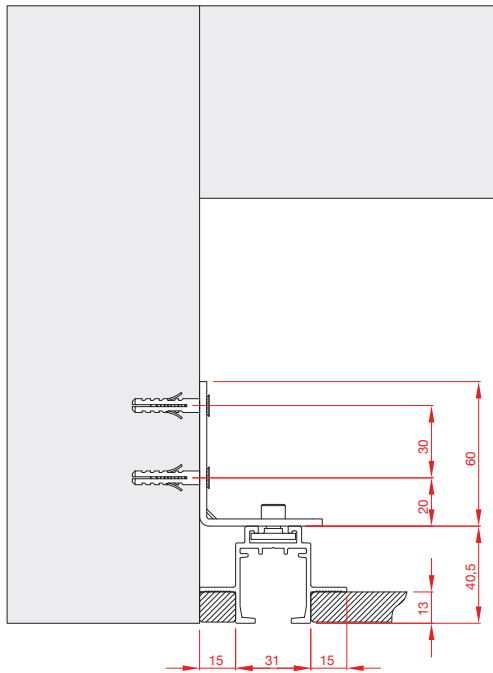

Plasterboard / Cartongesso

FULL CEILING FIXTURE SYSTEM SISTEMA PER FISSAGGIO SOFFITTO PIENO

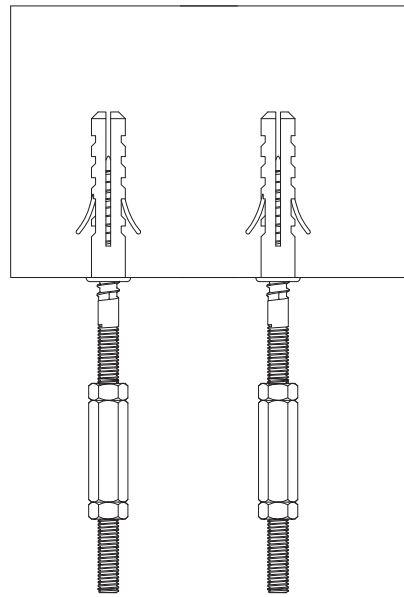
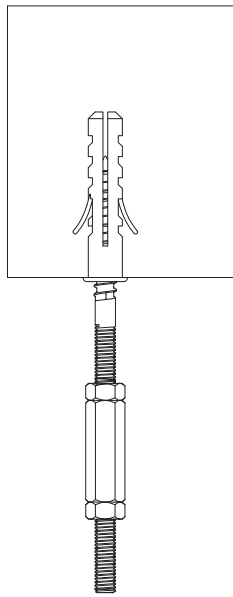

EMPTY CEILING FIXTURE SYSTEM SISTEMA PER FISSAGGIO SOFFITTO VUOTO

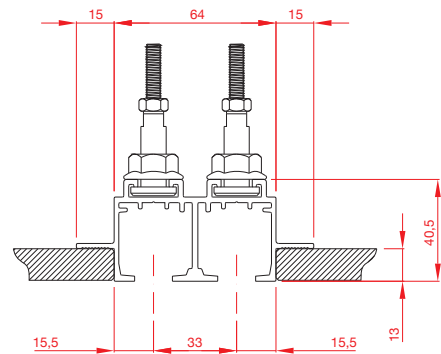
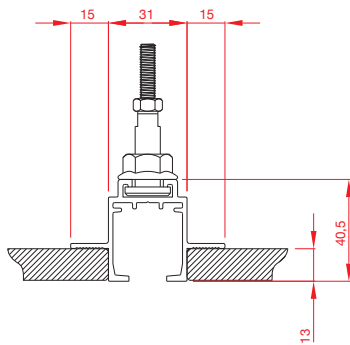
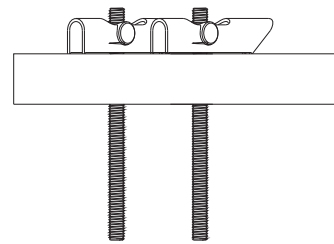
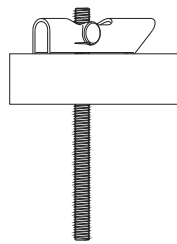



Pratico

System for folding doors
Sistema per porte pieghevoli

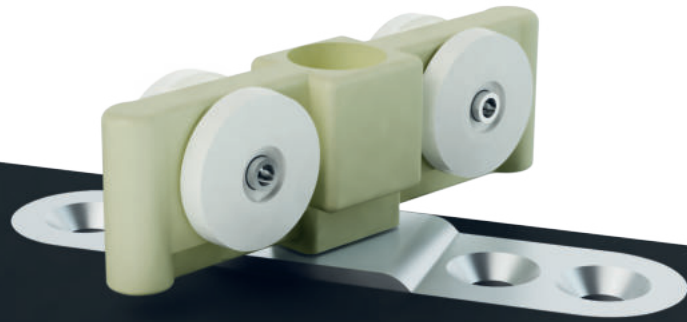



Pratico patented system is the ideal solution to convert already produced swing doors in folding doors.

The system is **extremely functional**, given that it **won't be necessary to modify already made outer jambs**.

Pratico is always combinable with invisible hinges, handles and locks dedicated to standard swing doors.

Pratico è il sistema brevettato ideale per la conversione di porte battenti in porte pieghevoli.

Il sistema è **estremamente funzionale**, poichè **non è necessario modificare gli stipiti esistenti**.

Pratico si può utilizzare con cerniere a scomparsa, maniglie e serrature per porte battenti.



Pratico COMPLETE BOX KIT / KIT COMPLETO IN SCATOLA 

| | | | |
|----------|--|---|---|
| K | Complete kit for N°1 folding door / Kit completo per N°1 porta a libro | | |
| | . | | |
| | 0201 |  | |
| | | . | |
| | | | 1 Without hinges Senza cerniere |
| | | | 2 With N°3 invisible hinges - ART. 1751 Con N°3 cerniere invisibili - ART. 1751 |
| | | | 3 With N°3 invisible hinges - ART. 1753 Con N°3 cerniere invisibili - ART. 1753 |
| | | | 4 With N°3 invisible hinges - ART. 1755 Con N°3 cerniere invisibili - ART. 1755 |
| | | | 5 With N°3 invisible hinges - ART. 1757 Con N°3 cerniere invisibili - ART. 1757 |



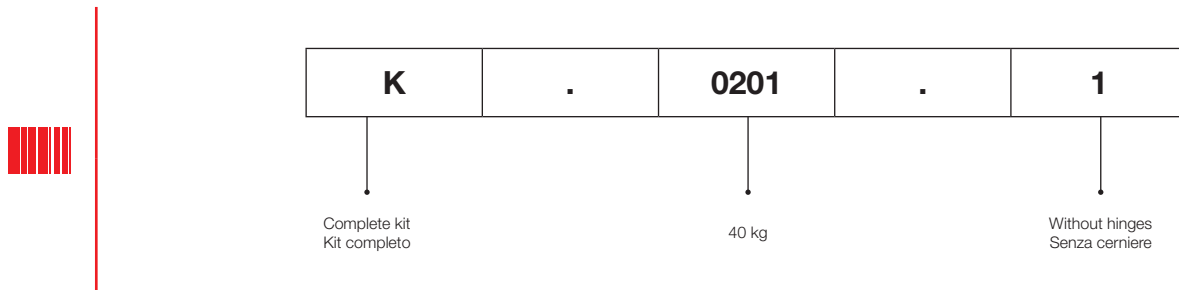

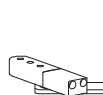
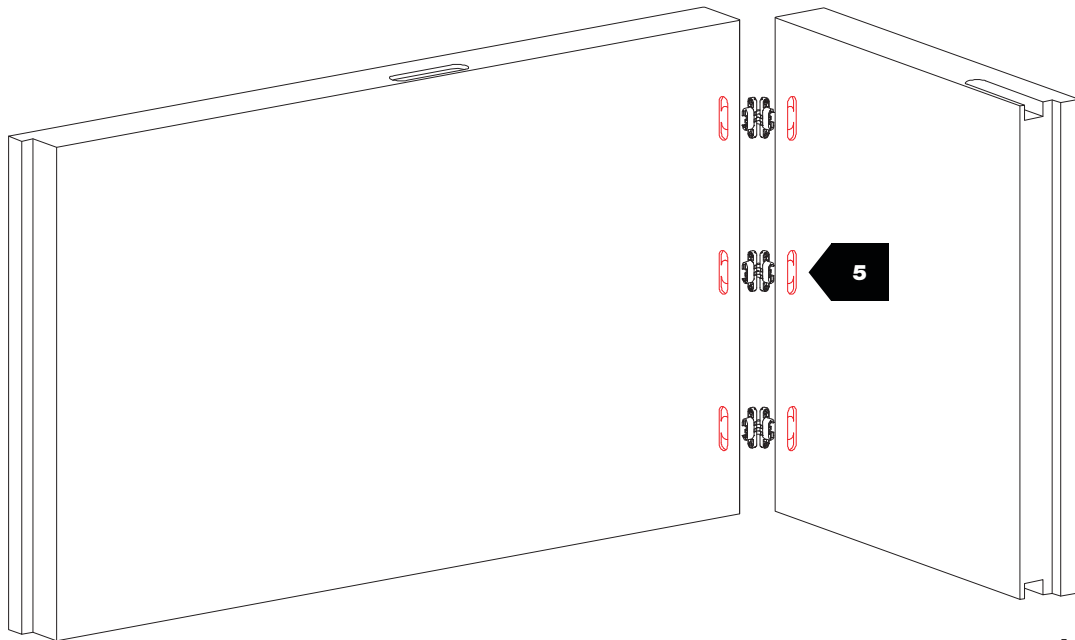
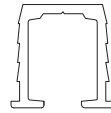
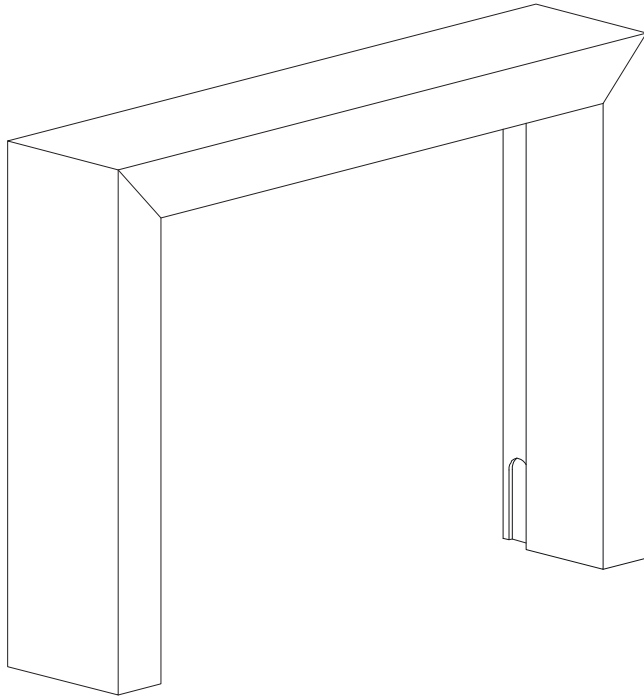

EXAMPLE / ESEMPIO



| | | | |
|------------------------|---|---|-----------------|
| Tracks / Binari | | ALUMINUM FINISHES CODES / CODICI FINITURE ALLUMINIO  | |
| CODE / CODICE | FINISH COLOR / COLORE FINITURA | | |
| 8 01 0.0 |  01 A | Anodized Silver / Argento | STANDARD |

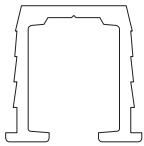
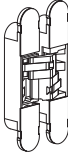

Max 40 kg

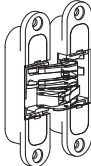
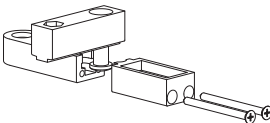
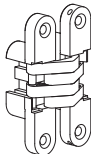
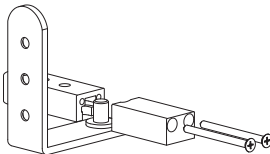
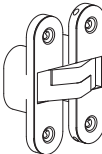
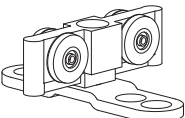
| N° |  | |  | | N° |  | |  | |
|----|---|---|---|--|----|---|---|---|--|
| 1 | 1990 8 01 0.01990 |  | 40 | | 5 | 1751/N |  | 40 | |
| | 1990/100/A S.1990/100/A |  | 40 | | | 1753/N |  | 40 | |
| 2 | 1993 |  | 40 | | | 1755/N |  | 40 | |
| 3 | 1994 |  | 40 | | | 1757/PI |  | 40 | |
| 4 | 1992 |  | 40 | | | | | | |



Max 40 kg



No hinges
Senza cerniere

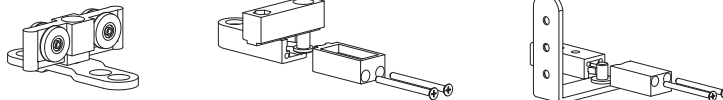

| OLD CODE | NEW CODE |  |
|-----------|----------|---|
| 1992/1993 | K.0201.1 | 5x |



Max 40 kg



N°3 Hinges 1751/N
N° 3 Cerniere 1751/N

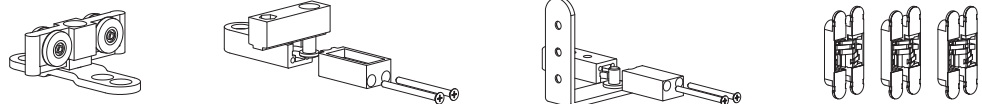

| OLD CODE | NEW CODE |  |
|-------------|----------|---|
| 1992/1751/N | K.0201.2 | 5x |



Max 40 kg



N°3 Hinges 1753/N
N° 3 Cerniere 1753/N

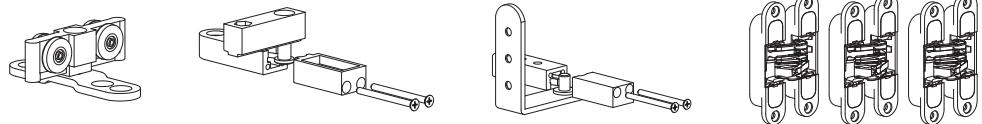

| OLD CODE | NEW CODE |  |
|-------------|----------|---|
| 1992/1753/N | K.0201.3 | 5x |



Max 40 kg



N°3 Hinges 1755/N
N° 3 Cerniere 1755/N

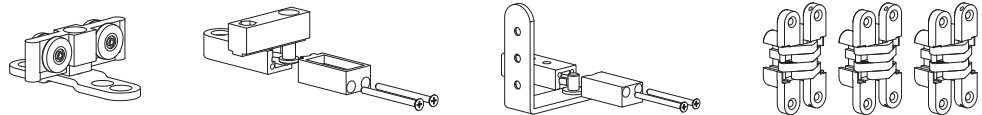

| OLD CODE | NEW CODE |  |
|-------------|----------|---|
| 1992/1755/N | K.0201.4 | 5x |



Max 40 kg



N°3 Hinges 1757/PI
N° 3 Cerniere 1757/PI

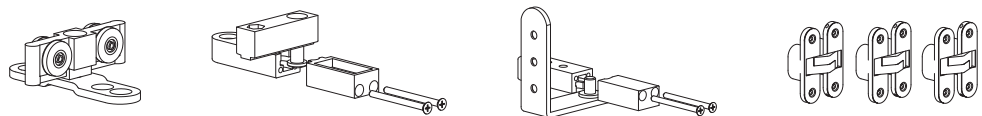

| OLD CODE | NEW CODE |  |
|--------------|----------|---|
| 1992/1757/PI | K.0201.5 | 5x |

ASSEMBLY DESCRIPTION / DESCRIZIONE MONTAGGIO

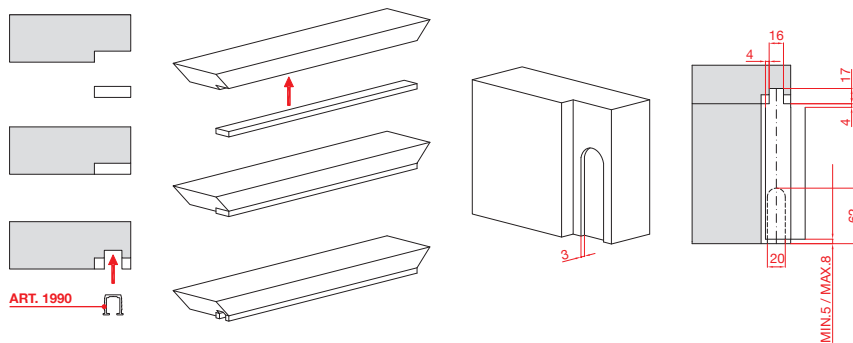

Carry out the specified processing

Eeguire le lavorazioni indicate

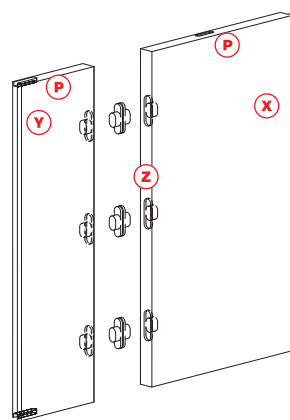

As to make a folding door, it is possible to cut an hinged door, fitting the solid blocs in the "Z" parts, then bordered and cut to fit the hinges, in the "P" point, cut the upper door closing

Per realizzare la porta pieghevole è possibile tagliare la porta battente, inserendo poi nelle parti "Z" i masselli, successivamente bordati e fresati per l'inserimento delle cerniere, nel punto "P" fresare la battuta superiore

ASSEMBLY DESCRIPTION / DESCRIZIONE MONTAGGIO

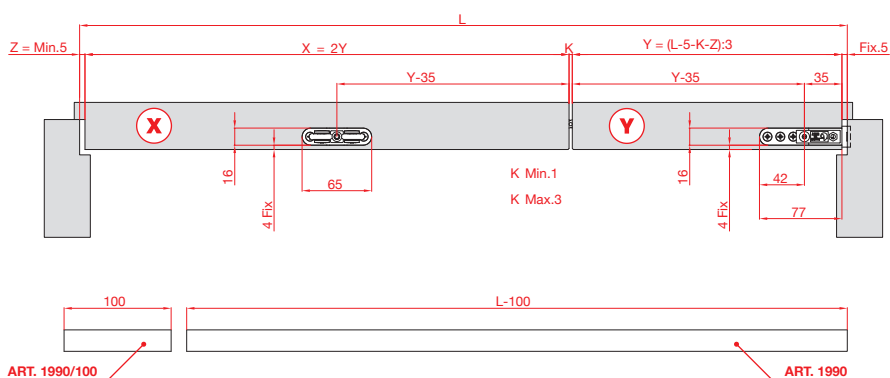
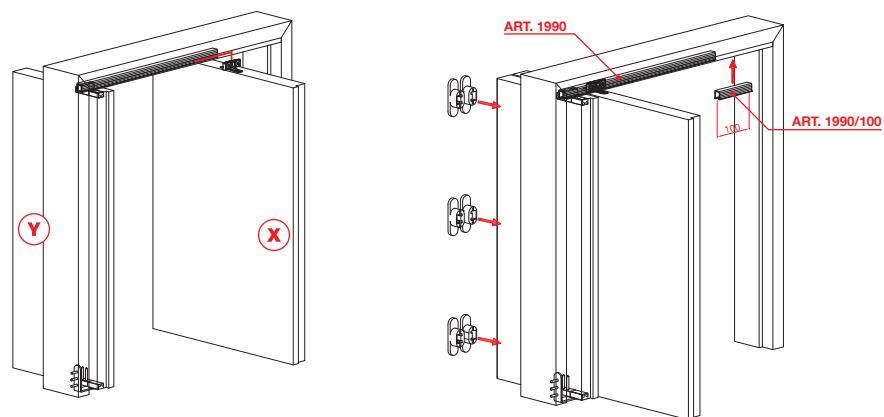

Use disappearing hinges.
It is possible to fit any handle.

Utilizzare cerniere a scomparsa.
È possibile inserire qualsiasi tipo di maniglia.



Profiles / Profili

Closure profiles with gaskets
Profili con guarnizioni per chiusure



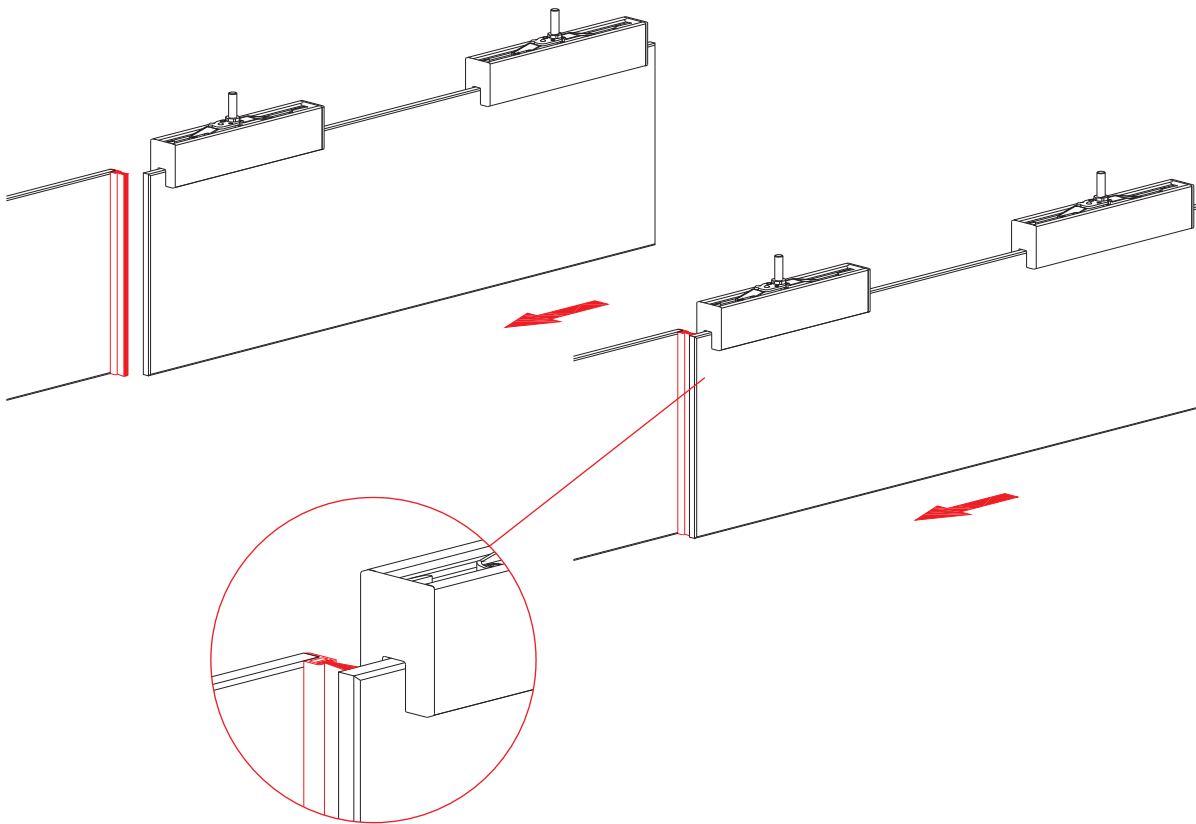

PROFILES / PROFILI



ART. 2264



ART. 266

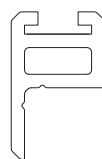

ART. 2262



ART. 543

ANTI-DUST BRUSH / SPAZZOLINO PARAPOLVERE

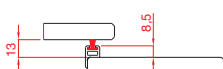

ART. 543/7

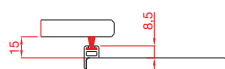

ART. 543/9

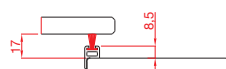

ART. 543/11

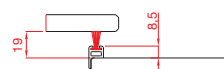

ART. 543/13

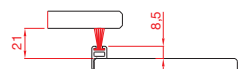

ART. 543/15

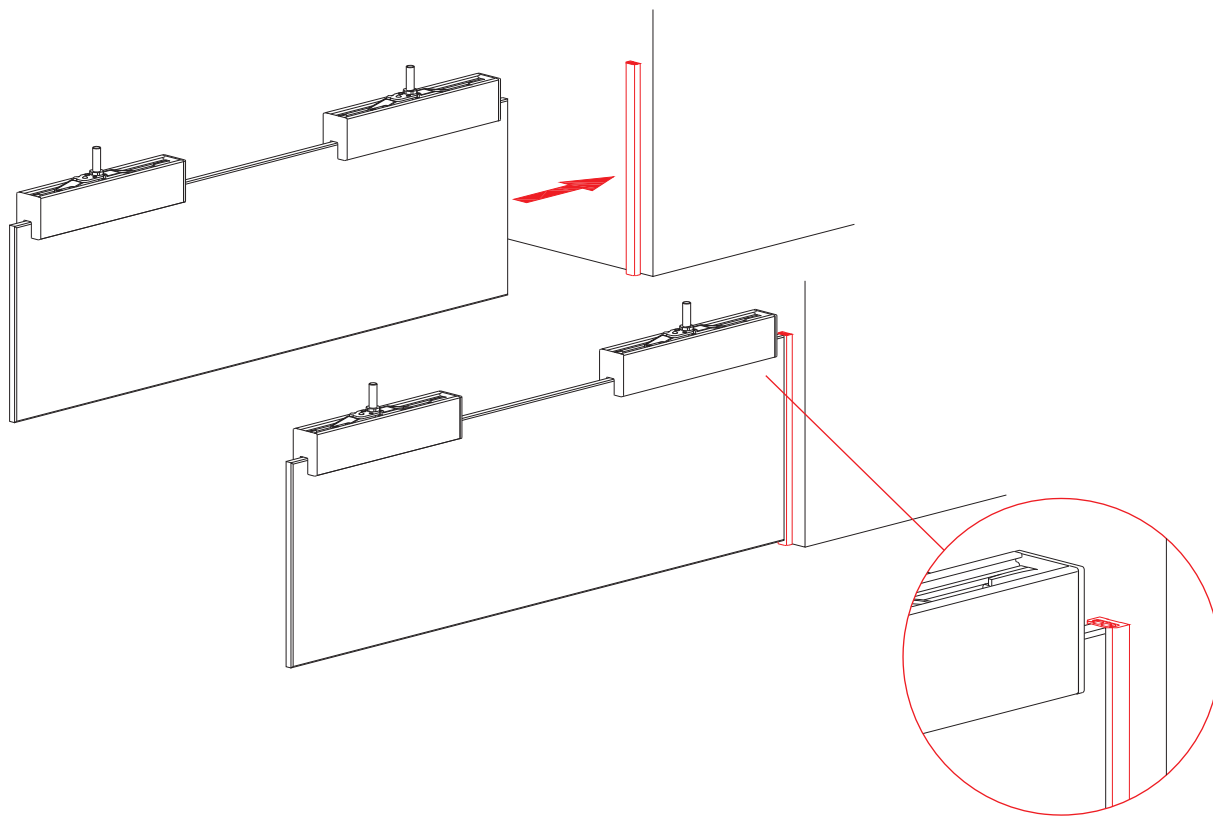

PROFILES / PROFILI



ART. 2264



ART. 266

MEASUREMENTS DESCRIPTION / DESCRIZIONE MISURE

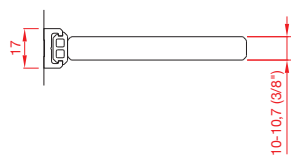
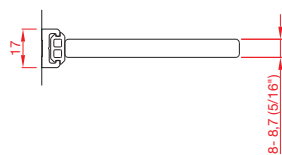

ART. 2264 / ART. 266

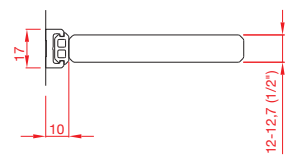

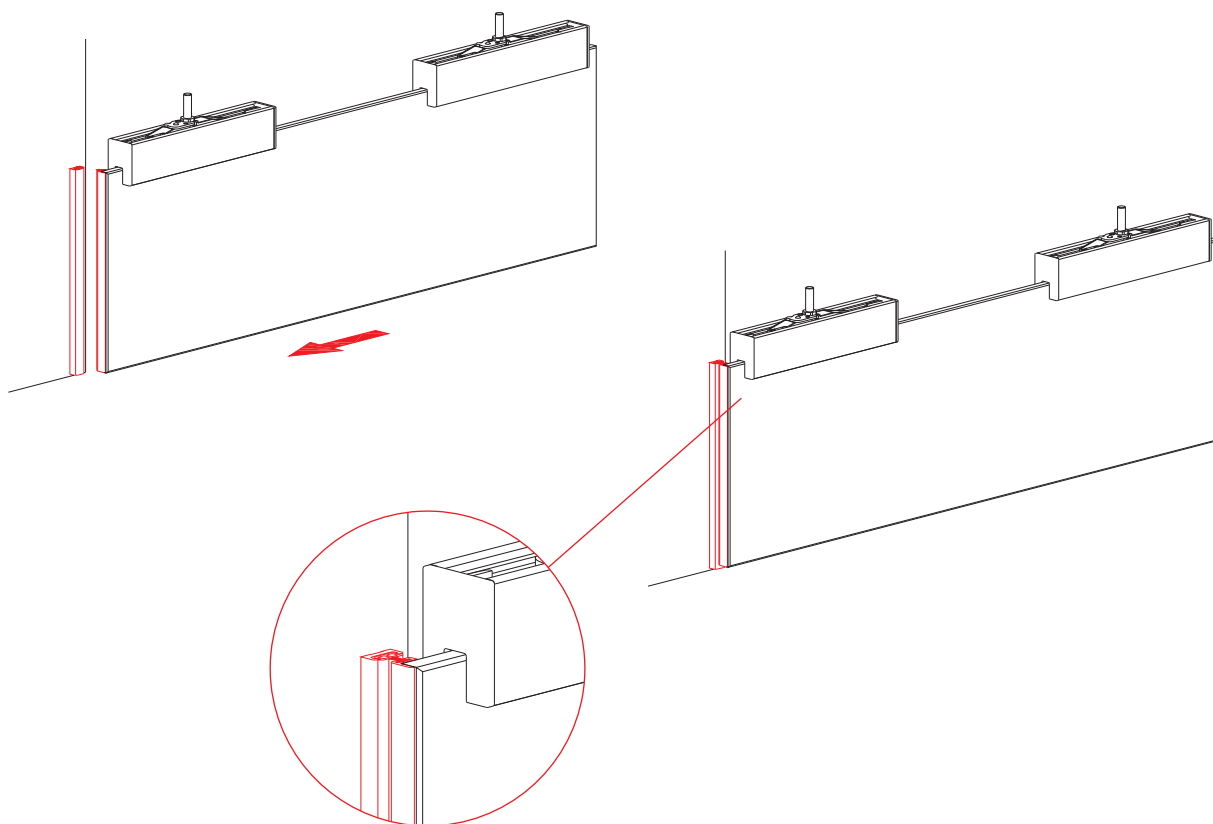

PROFILES / PROFILI

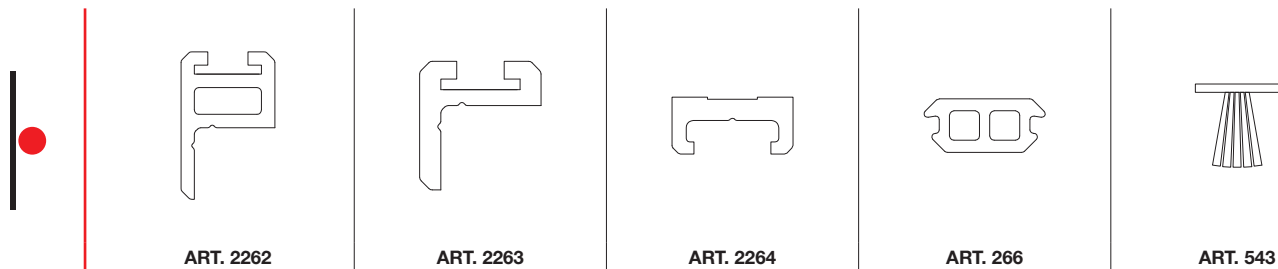

ART. 2262

ART. 2263

ART. 2264

ART. 266

ART. 543

ANTI-DUST BRUSH / SPAZZOLINO PARAPOLVERE

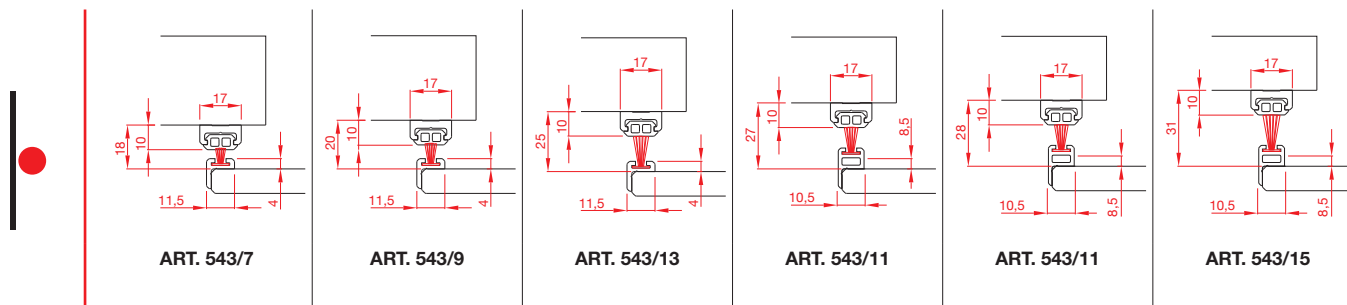

ART. 543/7

ART. 543/9

ART. 543/13

ART. 543/11

ART. 543/11

ART. 543/15



Pronto

Single body clamps ready for assembling, without holes in the glass
Ganasce a corpo unico pronte per il fissaggio, senza fori nel vetro

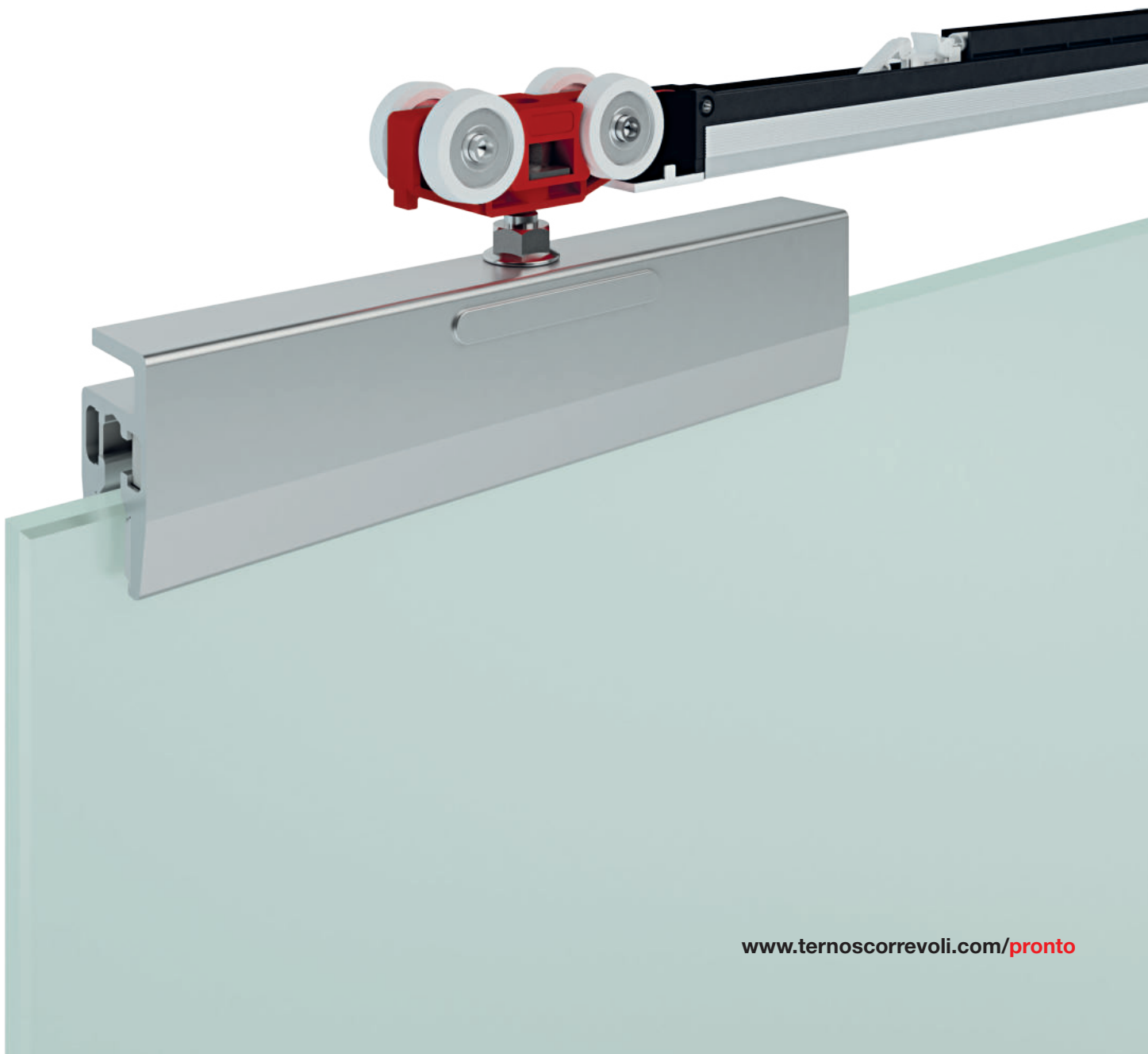



Sliding system ready to be fixed

Pronto is a sliding system **very easy to be mounted**: the clamps are completely pre-assembled and ready to be fixed on glass doors, and do not require further processing.

The system is compatible with monolithic or stratified glass, with thicknesses of 8-8,7 mm (5/16"), 10-10,7 mm (3/8") and 12-12,7 mm (1/2").

Pronto integrates the new sliding trolleys, with **Fluid** technology: the movement turns out to be extremely soft, in opening and closing, for a constantly improved user experience.

Il sistema pronto per il fissaggio



Pronto è un sistema scorrevole **estremamente facile da installare**: le ganasce a corpo unico sono infatti premontate e pronte per il fissaggio su porte in vetro, e non richiedono ulteriori lavorazioni.

Il sistema è compatibile con vetri monolitici o stratificati, con spessori da 8-8,7 mm (5/16"), 10-10,7 mm (3/8") and 12-12,7 mm (1/2").

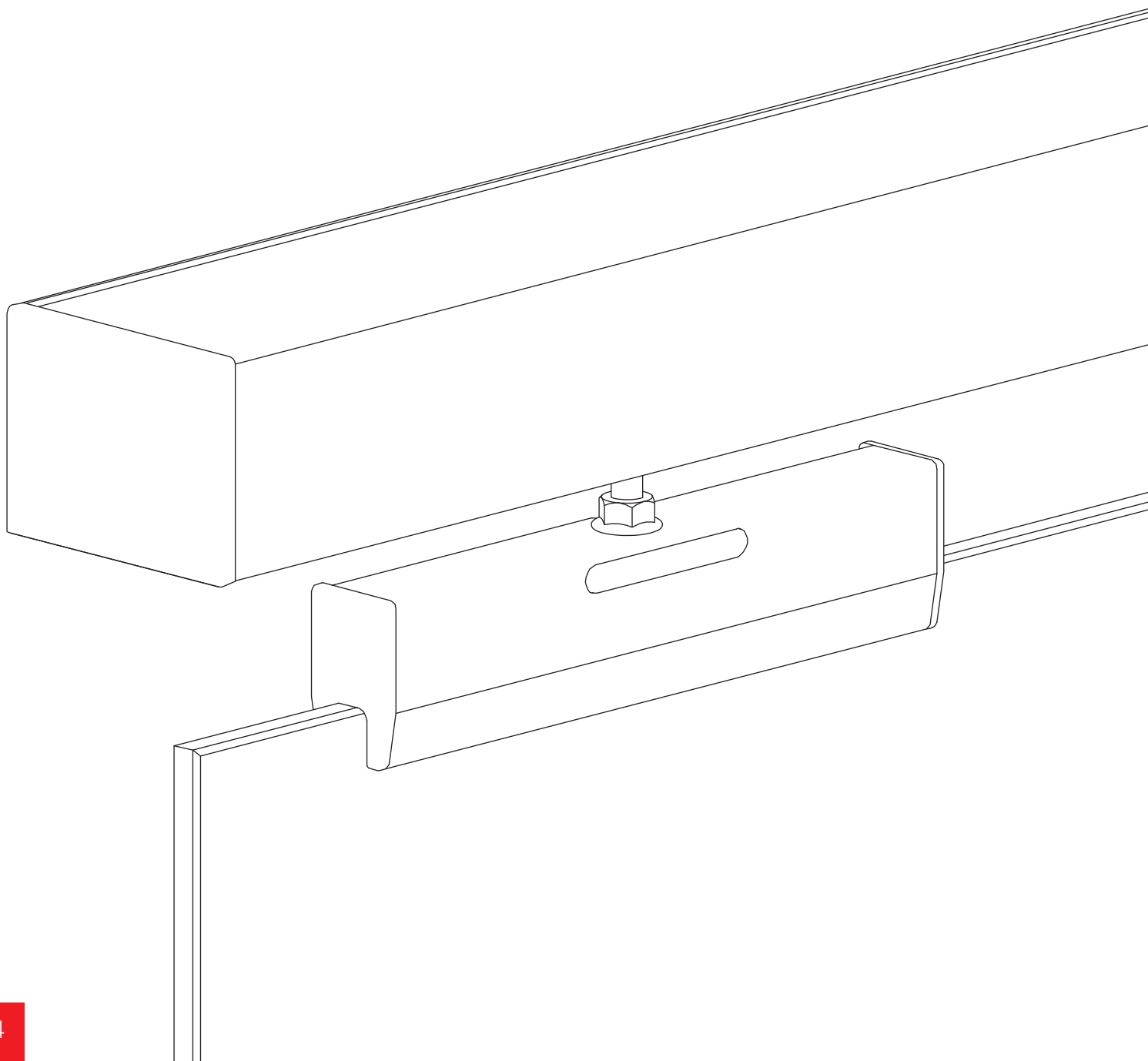
Pronto integra i nuovi scorrevoli con tecnologia **Fluid**: il movimento risulta così estremamente morbido, in apertura e in chiusura, per un'esperienza di utilizzo sempre migliorata.



Pronto COMPLETE BOX KIT / KIT COMPLETO IN SCATOLA 

| | | | |
|----------|-----------------------------|---|--|
| K | Complete kit / Kit completo | | |
| | | | |
| | 0351 |  | Glass thickness 8-8,7 mm - 5/16" Vetro spessore 8-8,7 mm - 5/16" |
| | 0352 |  | Glass thickness 10-10,7 mm - 3/8" Vetro spessore 10-10,7 mm - 3/8" |
| | 0353 |  | Glass thickness 12-12,7 mm - 1/2" Vetro spessore 12-12,7 mm - 1/2" |
| | | | |
| | | | 0 Lower guide / Guida inferiore 110 mm |
| | | | 3 Lower guide / Guida inferiore 112 mm |
| | | | 4 Lower guide / Guida inferiore 118 mm |
| | | | 5 N.1 Fluid damper + N.1 Shock absorber N.1 Fermo Fluid + N.1 Fermo a pinza ammortizzato |
| | | | 6 N.2 Fluid dampers N.2 Fermi ammortizzati Fluid |
| | | | 7 N.2 Shock absorber N.2 Fermi a pinza ammortizzati |

EXAMPLE / ESEMPIO

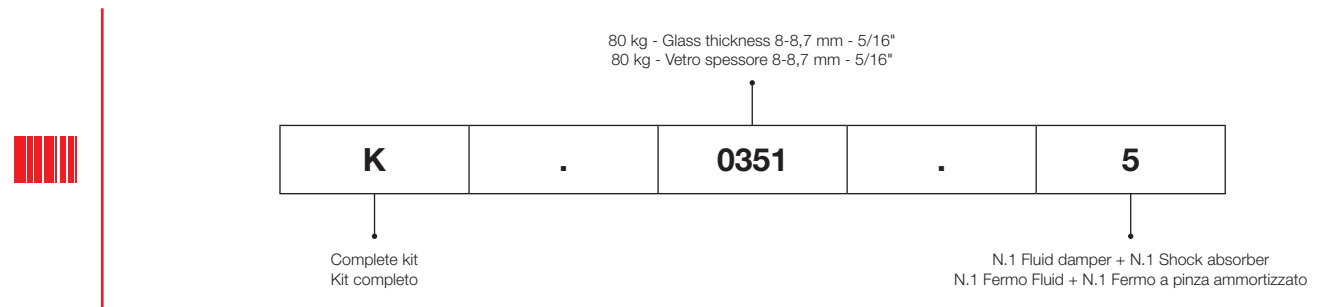

| | | | | |
|------------------------|-------------|---|-----------------|---|
| Tracks / Binari | | ALUMINUM FINISHES CODES / CODICI FINITURE ALLUMINIO | |  |
| CODE / CODICE | | FINISH COLOR / COLORE FINITURA | | |
| 8 01 0.0 | 01 A | Anodized Silver / Argento | STANDARD | |

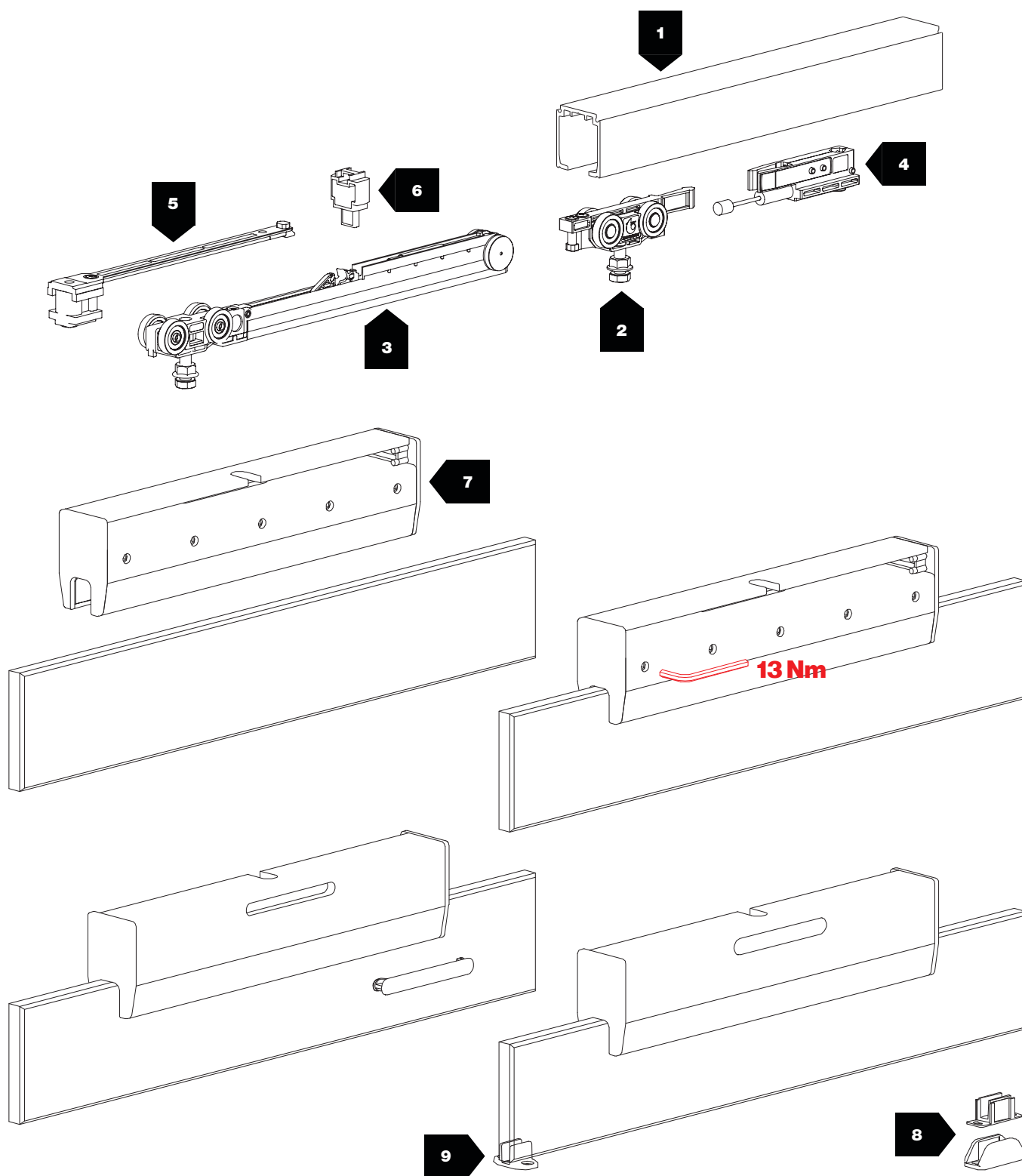











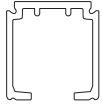
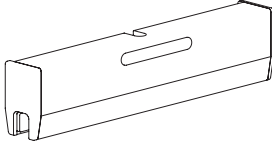
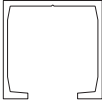
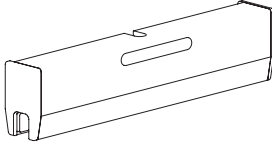
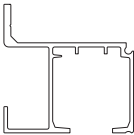
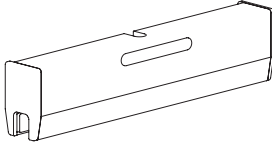

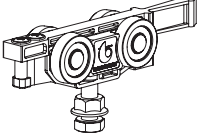

8-8,7 ÷ 12-12,7 mm

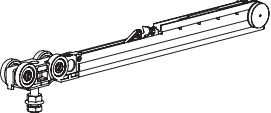

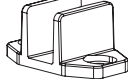
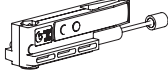
80 kg

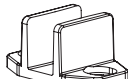
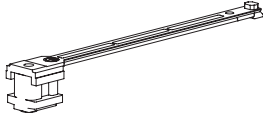

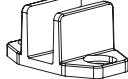
10 mm

| N° | Barcode | | kg | | N° | Barcode | | kg | |
|----|----------------------|---|----|---|---------|---|---|---|--|
| 1 | 1280 8 01 0.01280 |  | - | | 7 | 1780/8 |  | - | Glass thk. Vetri sp. 8-8,7 mm (5/16") |
| | 1080 8 01 0.01080 |  | - | | | 1780/10 |  | - | Glass thk. Vetri sp. 10-10,7 mm (3/8") |
| | 1359 8 01 0.01359 |  | - | | | 1780/12 |  | - | Glass thk. Vetri sp. 12-12,7 mm (1/2") |
| | 1700 8 01 0.01700 |  | - | | 8 | 1486/8 |  | 80 | Glass thk. Vetri sp. 8-8,7 mm (5/16") |
| | 1720 8 01 0.01720 |  | - | | | 1486/10 |  | 80 | Glass thk. Vetri sp. 10-10,7 mm (3/8") |
| 2 | 3388/P |  | 80 |  NEW | 1486/12 |  | 80 | Glass thk. Vetri sp. 12-12,7 mm (1/2") | |
| 3 | 3382/080/P |  | 80 |  NEW | 9 | 118 |  | 80 | Glass thk. Vetri sp. 8-8,7 mm (5/16") OPTIONAL + |
| 4 | 3355/080 |  | 80 |  NEW | | 110 |  | 80 | Glass thk. Vetri sp. 10-10,7 mm (3/8") OPTIONAL + |
| 5 | 3354 |  | 80 |  NEW | | 112 |  | 80 | Glass thk. Vetri sp. 12-12,7 mm (1/2") OPTIONAL + |
| 6 | 3347 |  | - | | | | | | |

Pronto

Single body clamps ready for assembling
Ganasce a corpo unico pronte per il fissaggio

FLUID

- N.2 Shock absorbers
N.2 Fermi a pinza ammortizzati
- Ball bearings
Cuscinetti a sfera



| OLD CODE | NEW CODE | | | | |
|----------|----------|-------------------|-------|-------------|----|
| - | K.0351.7 | 8-8,7 mm (5/16") | 80 kg | Min. 600 mm | 5x |
| - | K.0352.7 | 10-10,7 mm (3/8") | | | 5x |
| - | K.0353.7 | 12-12,7 mm (1/2") | | | 5x |

FLUID

- N.1 Fluid damper
N.1 Fermo ammortizzato Fluid
- N.1 Shock absorber
N.1 Fermo a pinza ammortizzato
- Ball bearings
Cuscinetti a sfera

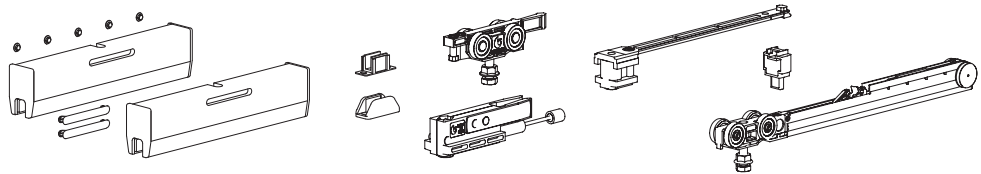

| OLD CODE | NEW CODE | | | | |
|----------|----------|-------------------|-------|-------------|----|
| - | K.0351.5 | 8-8,7 mm (5/16") | 80 kg | Min. 650 mm | 4x |
| - | K.0352.5 | 10-10,7 mm (3/8") | | | 4x |
| - | K.0353.5 | 12-12,7 mm (1/2") | | | 4x |

FLUID

- N.2 Fluid dampers
N.2 Fermi ammortizzati Fluid
- Ball bearings
Cuscinetti a sfera

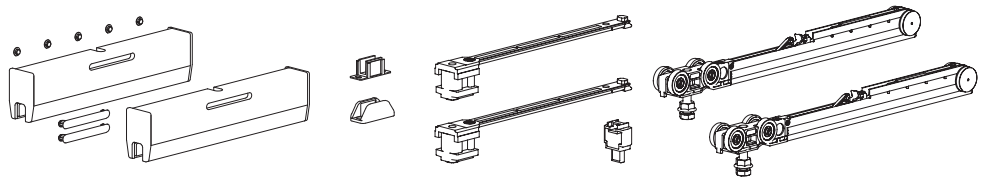

| OLD CODE | NEW CODE | | | | |
|----------|----------|-------------------|-------|-------------|----|
| - | K.0351.6 | 8-8,7 mm (5/16") | 80 kg | Min. 860 mm | 4x |
| - | K.0352.6 | 10-10,7 mm (3/8") | | | 4x |
| - | K.0353.6 | 12-12,7 mm (1/2") | | | 4x |

- Kit for existing counter-frames
Kit per controlelai esistenti

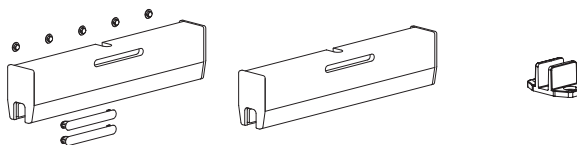

| OLD CODE | NEW CODE | | |
|----------|----------|-------------------|----|
| 1780/118 | K.0351.4 | 8-8,7 mm (5/16") | 5x |
| 1780/110 | K.0352.0 | 10-10,7 mm (3/8") | 5x |
| 1780/112 | K.0353.3 | 12-12,7 mm (1/2") | 5x |

LOWER GUIDES (COUNTERFRAMES) / GUIDE INFERIORI (CONTROTELAI)

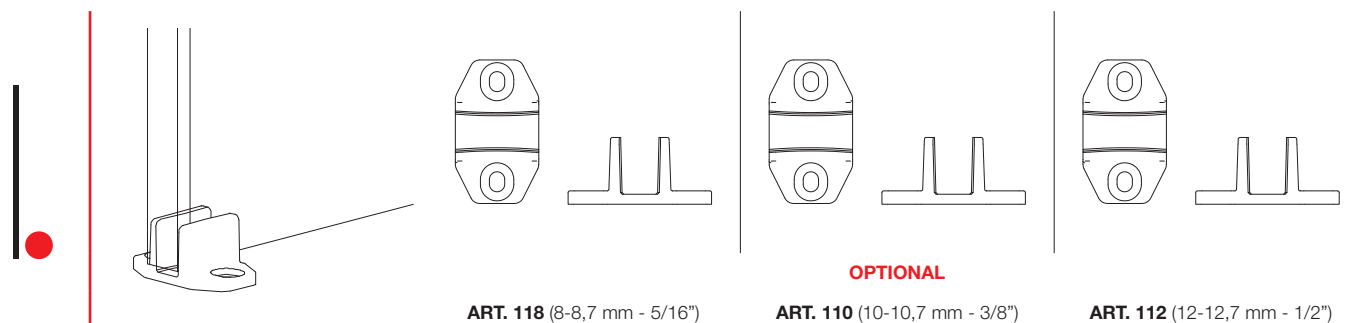

ART. 118 (8-8,7 mm - 5/16")

OPTIONAL
ART. 110 (10-10,7 mm - 3/8")

ART. 112 (12-12,7 mm - 1/2")

MEASUREMENTS DESCRIPTION / DESCRIZIONI MISURE

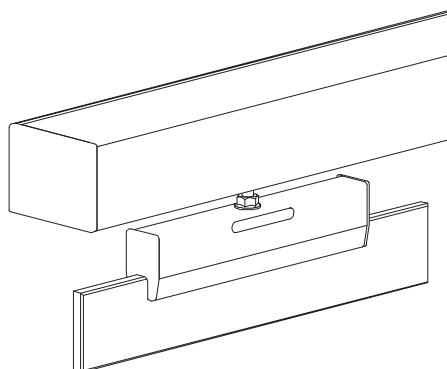
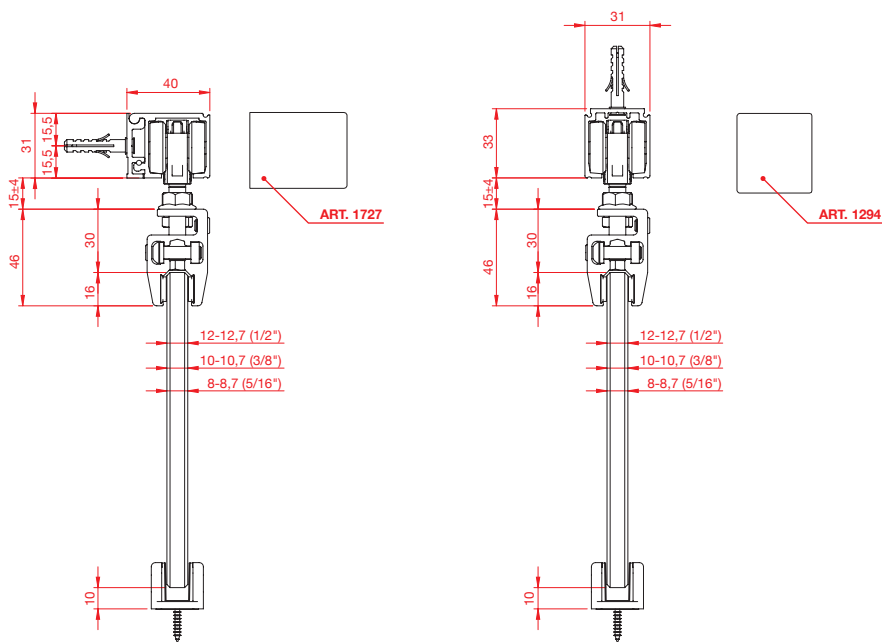
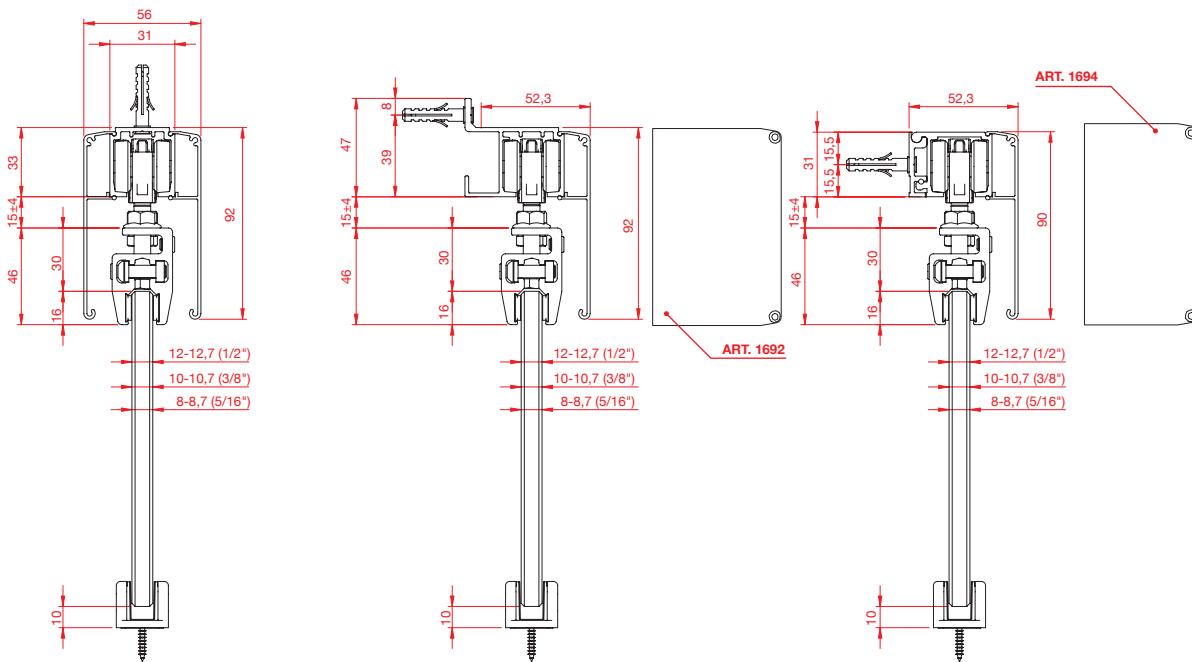



Selfie

Systems for doors with automatic closure
Sistemi per porte con chiusura automatica

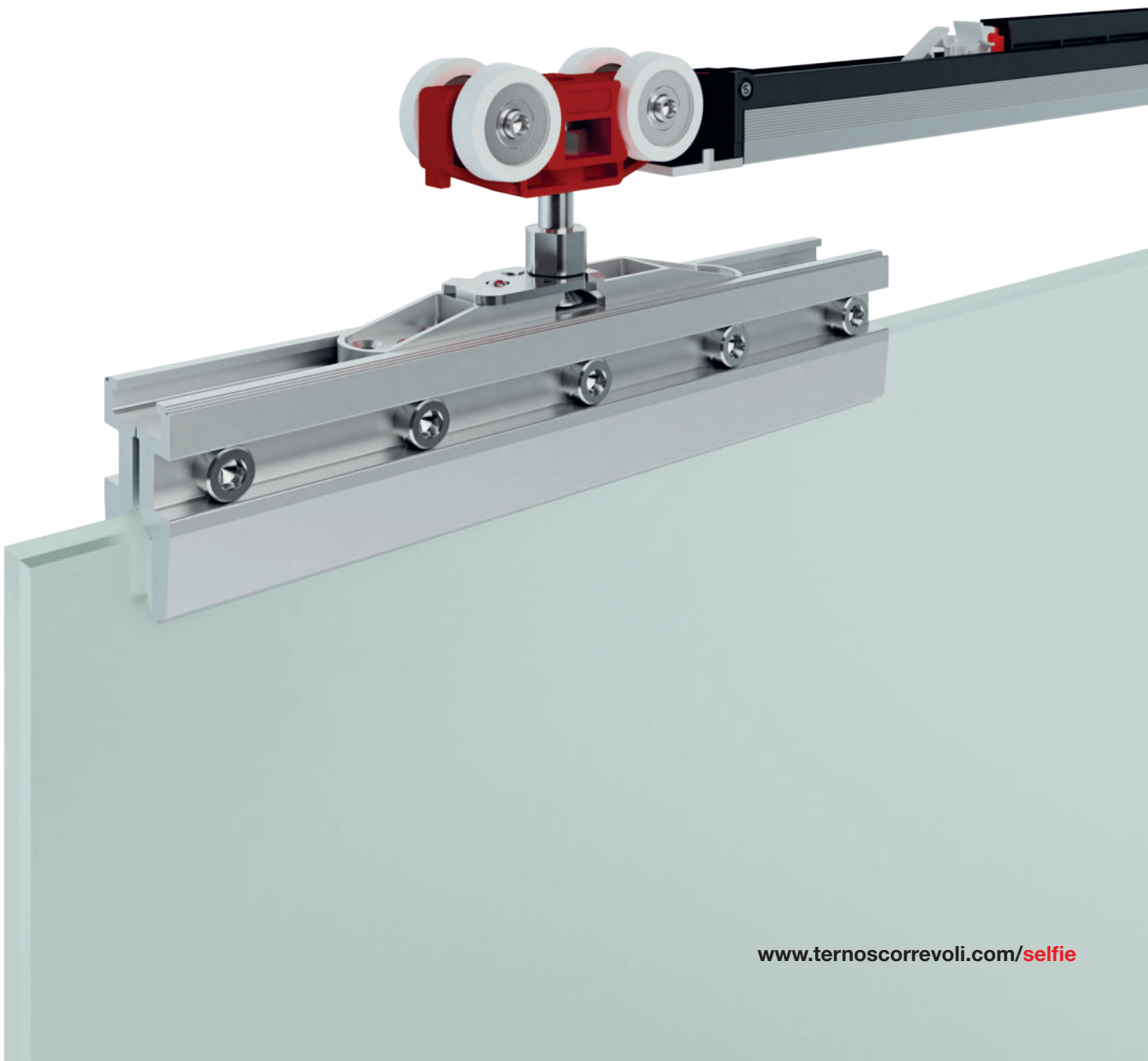



Selfie is an **innovative system** suitable for glass doors **with automatic self closing, which does not require any type of electrical equipment.**

The system is available with our **Vetro 24, Vetro 40** and **Pronto** systems, which integrate the innovative **Fluid** technology: the opening and closing movement is even lighter and more smooth, without the need of any kind of effort.

Finally, the **Selfie** system is available for mounting on counter frames.

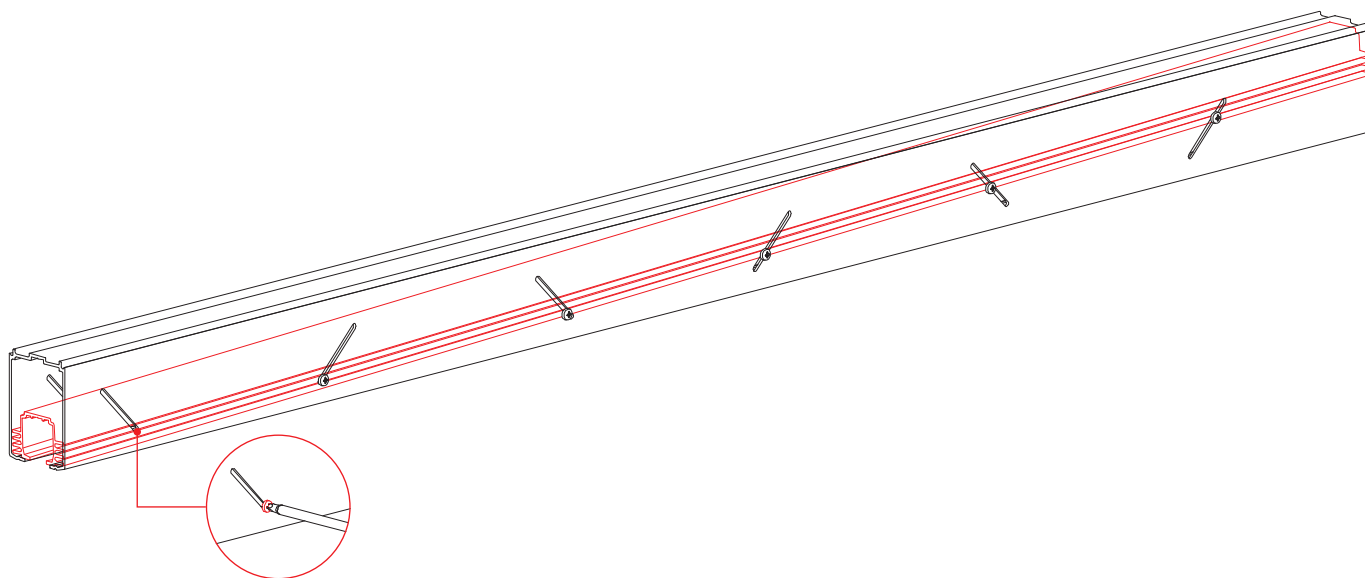

Il sistema **Selfie** per porte in vetro è l'innovativo sistema di Terno Scorrevoli per porte con chiusura automatica, che **non necessita di alcun tipo di azionamento elettrico.**

Il sistema è disponibile con i nostri sistemi **Vetro 24, Vetro 40** e **Pronto** che integrano l'innovativa tecnologia **Fluid**: il movimento in apertura e in chiusura risulta ancora più leggero e fluido, senza sforzo.

Il sistema **Selfie** è disponibile, infine, per il montaggio su controtelai.



| Selfie | | COMPLETE BOX KIT / KIT COMPLETO IN SCATOLA | | | |
|---------------|-----------------------------|---|----------|--|--|
| K | Complete kit / Kit completo | | | | |
| 0162 | | Vetro 24 (Glass thickness 8-8,7 mm - 5/16") Vetro 24 (Vetro spessore 8-8,7 mm - 5/16") | | | |
| 0163 | | Vetro 40 (Glass thickness 10-10,7 mm - 3/8") Vetro 40 (Vetro spessore 10-10,7 mm - 3/8") | | | |
| 0164 | | Vetro 40 (Glass thickness 8-8,7 mm - 5/16") Vetro 40 (Vetro spessore 8-8,7 mm - 5/16") | | | |
| 0165 | | Vetro 40 (Glass thickness 10-10,7 mm - 3/8") Vetro 40 (Vetro spessore 10-10,7 mm - 3/8") | | | |
| 0166 | | Vetro 40 (Glass thickness 12-12,7 mm - 1/2") Vetro 40 (Vetro spessore 12-12,7 mm - 1/2") | | | |
| 0167 | | Pronto (Glass thickness 8-8,7 mm - 5/16") Pronto (Vetro spessore 8-8,7 mm - 5/16") | | | |
| 0168 | | Pronto (Glass thickness 10-10,7 mm - 3/8") Pronto (Vetro spessore 10-10,7 mm - 3/8") | | | |
| 0169 | | Pronto (Glass thickness 12-12,7 mm - 1/2") Pronto (Vetro spessore 12-12,7 mm - 1/2") | | | |
| | | | 2 | N.1 Fluid damper + N.1 Push Magnetic N.1 Fermo ammortizzato Fluid + N.1 Push Magnetic | |
| | | | 3 | N.1 Shock absorber + N.1 Push Magnetic N.1 Fermo a pinza ammortizzato + N.1 Push Magnetic | |
| | | | | C | With cover Con copertura |
| | | | | S | Without cover Senza copertura |
| | | | | | 01 Anodized Silver Finish Finitura Argento |

EXAMPLE / ESEMPIO

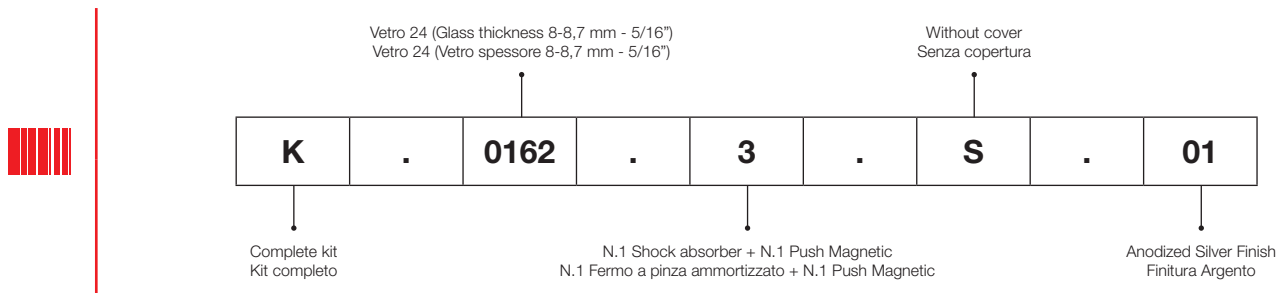

| Tracks / Binari | | ALUMINUM FINISHES CODES / CODICI FINITURE ALLUMINIO | | |
|------------------------|--------------------------------|---|--|-----------------|
| CODE / CODICE | FINISH COLOR / COLORE FINITURA | | | |
| 8 01 0.0 | | 01 A | Anodized Silver / Argento | STANDARD |
| 8 02 0.0 | | 02 AS | Brushed Anodized Silver / Argento Spazzolato | |

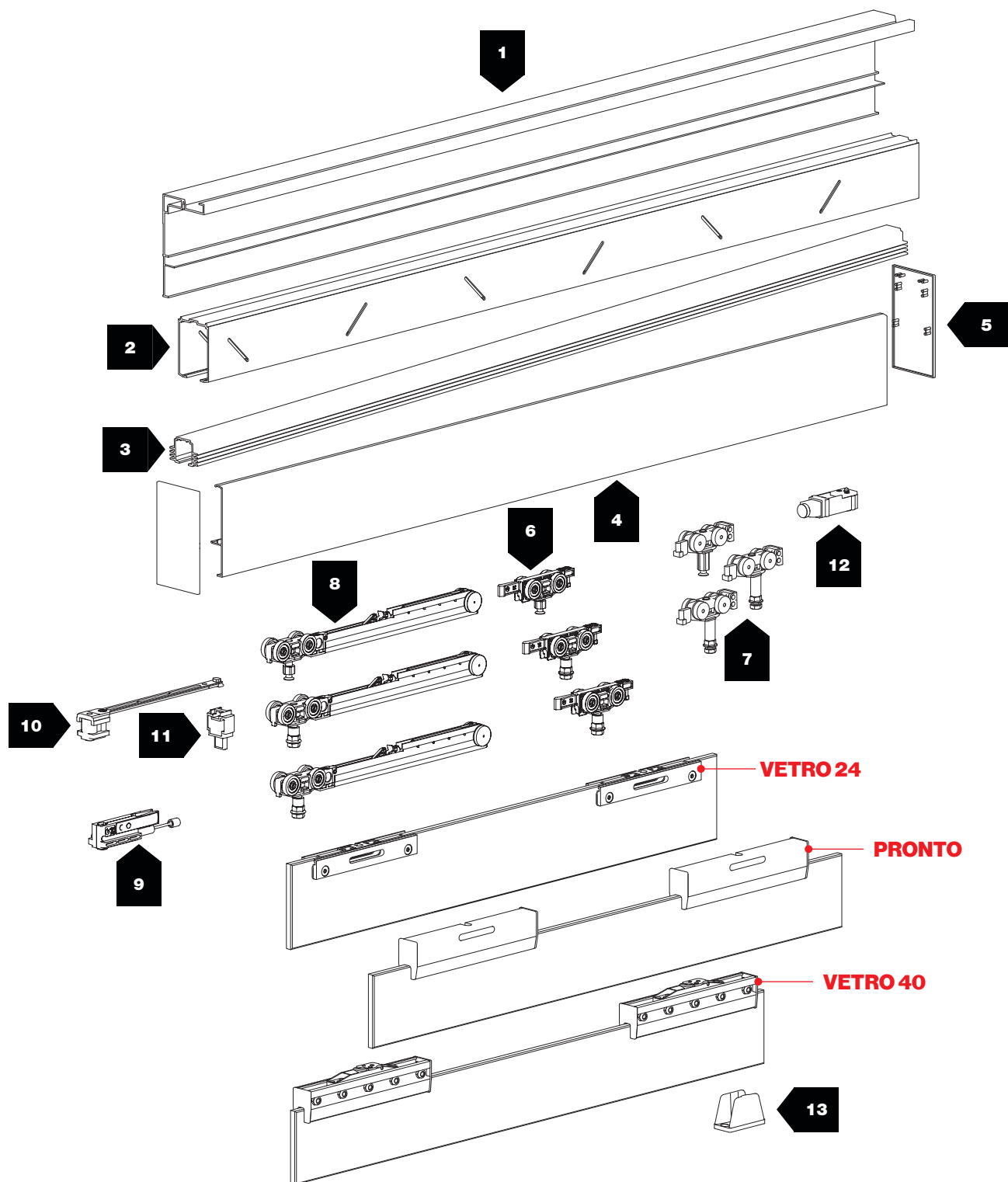



8-8,7 ÷ 12-12,7 mm







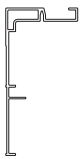
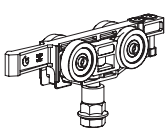
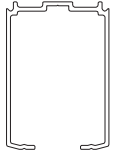
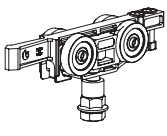
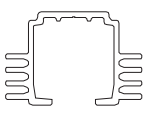
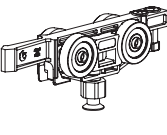

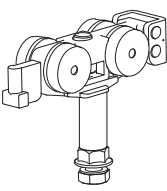
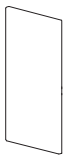
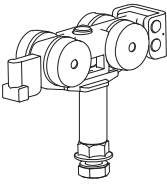
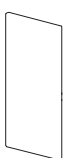
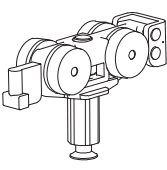

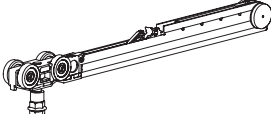

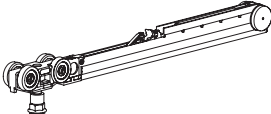
Max 80 kg

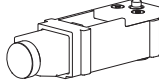
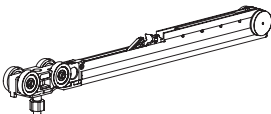

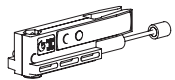
Min. 650 - Max. 1200 mm

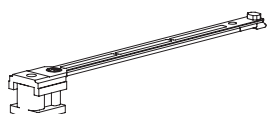
| N° | Barcode | | kg | | N° | Barcode | | kg | |
|----|---|---|----|--|----|----------|---|---|---------------------------------|
| 1 | 2430 8 01 0.02430 |  | - | | 6 | 2413/V24 |  | 80 | FLUVD NEW VETRO 24 |
| 2 | 2410 S.2410/A/1600 S.2410/A/2000 S.2410/A/2400 |  | - | | | 2413/P |  | 80 | FLUVD NEW PRONTO |
| 3 | 2400 S.2400/A/1600 S.2400/A/2000 S.2400/A/2400 |  | - | | | 2413/V40 |  | 80 | FLUVD NEW VETRO 40 |
| 4 | 2420 8 02 0.02420 |  | - | | | 2403/V24 |  | 80 | VETRO 24 |
| 5 | 2412 |  | - | | | 7 | 2403/P |  | 80 |
| | 2414 |  | - | | | 2403/V40 |  | 80 | VETRO 40 |

| N° | | | kg | | N° | | | kg | |
|----|--------------|---|----|---|----|----------|---|----|---|
| 8 | 2415/080/V24 |  | 80 |  NEW VETRO 24 | 11 | 3347 |  | — | |
| | 2415/080/P |  | 80 |  NEW PRONTO | 12 | 106/80/G |  | 80 | |
| | 2415/080/V40 |  | 80 |  NEW VETRO 40 | | 2405 | | 80 | Glass thk. Vetri sp. 8-8,7 mm (5/16") |
| 9 | 3355/080 |  | 80 |  NEW | 13 | 2407 |  | 80 | Glass thk. Vetri sp. 10-10,7 mm (3/8") |
| 10 | 3354 |  | 80 |  NEW | | 2409 | | 80 | Glass thk. Vetri sp. 12-12,7 mm (1/2") |

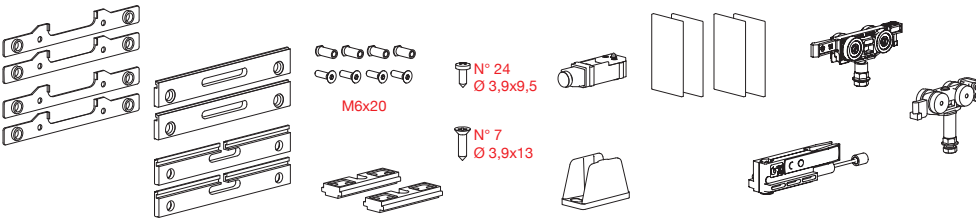



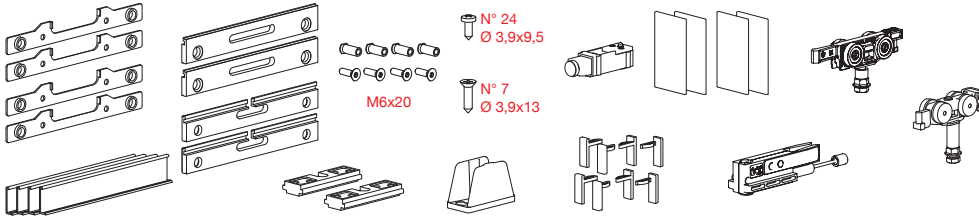

-  **80 kg**
-  N.1 Shock absorber
N.1 Fermo a pinza
ammortizzato
-  Ball bearings
Cuscinetti a sfera
-  **.01** Anodized Silver
Argento

| OLD CODE | NEW CODE |  |  |  |  |
|----------|----------------------|---|---|---|---|
| — | K.0162.3.S.01 | VETRO 24 | Without cover Senza copertura | 8-8,7 mm (5/16") | 5x |
| — | K.0163.3.S.01 | | | 10-10,7 mm (3/8") | 5x |

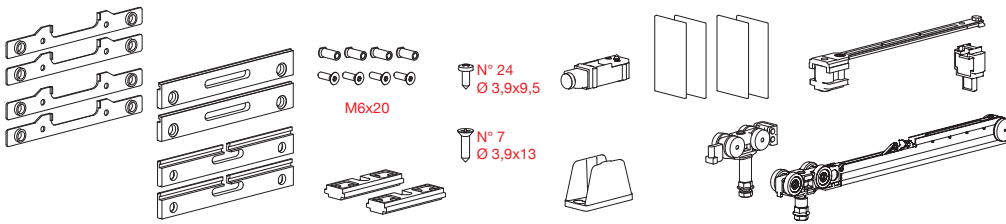

| OLD CODE | NEW CODE |  |  |  |  |
|----------|----------------------|---|---|---|---|
| — | K.0162.3.C.01 | VETRO 24 | With cover Con copertura | 8-8,7 mm (5/16") | 5x |
| — | K.0163.3.C.01 | | | 10-10,7 mm (3/8") | 5x |



-  **80 kg**
-  N.1 Fluid damper
N.1 Fermo ammortizzato
FLUID Fluid
-  Ball bearings
Cuscinetti a sfera
-  **.01** Anodized Silver
Argento

| OLD CODE | NEW CODE |  |  |  |  |
|----------|----------------------|---|---|---|---|
| — | K.0162.2.S.01 | VETRO 24 | Without cover Senza copertura | 8-8,7 mm (5/16") | 4x |
| — | K.0163.2.S.01 | | | 10-10,7 mm (3/8") | 4x |

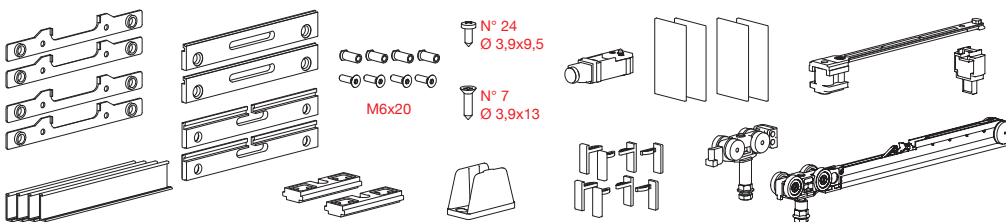

| OLD CODE | NEW CODE |  |  |  |  |
|----------|----------------------|---|---|---|---|
| — | K.0162.2.C.01 | VETRO 24 | With cover Con copertura | 8-8,7 mm (5/16") | 4x |
| — | K.0163.2.C.01 | | | 10-10,7 mm (3/8") | 4x |

FLUID

FLUID

Selfie

Systems for doors with automatic closure
Sistemi per porte con chiusura automatica

FLUID



80 kg



N.1 Shock absorber
N.1 Fermo a pinza
ammortizzato



Ball bearings
Cuscinetti a sfera



Anodized Silver
Argento

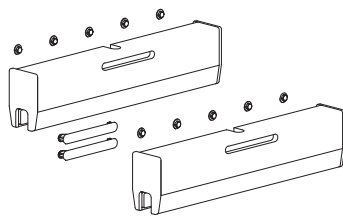

N° 24
Ø 3,9x9,5

N° 7
Ø 3,9x13

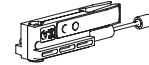
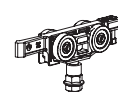
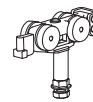
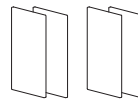

| OLD CODE | NEW CODE | | | |
|----------|-------------|--------|-------------------|----|
| — | K.0167.3.01 | PRONTO | 8-8,7 mm (5/16") | 5x |
| — | K.0168.3.01 | | 10-10,7 mm (3/8") | 5x |
| — | K.0169.3.01 | | 12-12,7 mm (1/2") | 5x |

FLUID



80 kg



N.1 Fluid damper
N.1 Fermo ammortizzato
Fluid



Ball bearings
Cuscinetti a sfera



Anodized Silver
Argento

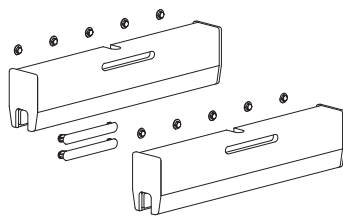

N° 24
Ø 3,9x9,5

N° 7
Ø 3,9x13

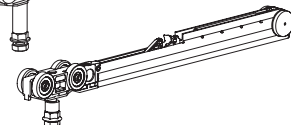
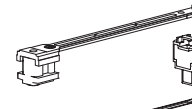
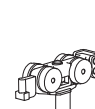
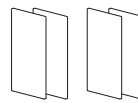

| OLD CODE | NEW CODE | | | |
|----------|-------------|--------|-------------------|----|
| — | K.0167.2.01 | PRONTO | 8-8,7 mm (5/16") | 4x |
| — | K.0168.2.01 | | 10-10,7 mm (3/8") | 4x |
| — | K.0169.2.01 | | 12-12,7 mm (1/2") | 4x |

FLUID

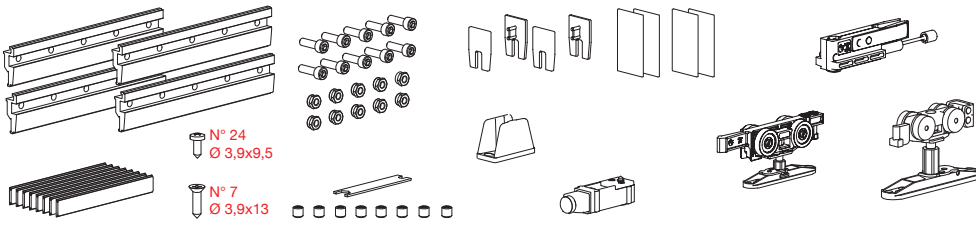

- 80 kg**
- N.1 Shock absorber
N.1 Fermo a pinza
ammortizzato
- Ball bearings
Cuscinetti a sfera
- .01** Anodized Silver
Argento

| OLD CODE | NEW CODE | | | | |
|----------|----------------------|-----------------|----------------------------------|-------------------|----|
| — | K.0164.3.S.01 | VETRO 40 | Without cover Senza copertura | 8-8,7 mm (5/16") | 5x |
| — | K.0165.3.S.01 | | | 10-10,7 mm (3/8") | 5x |
| — | K.0166.3.S.01 | | | 12-12,7 mm (1/2") | 5x |

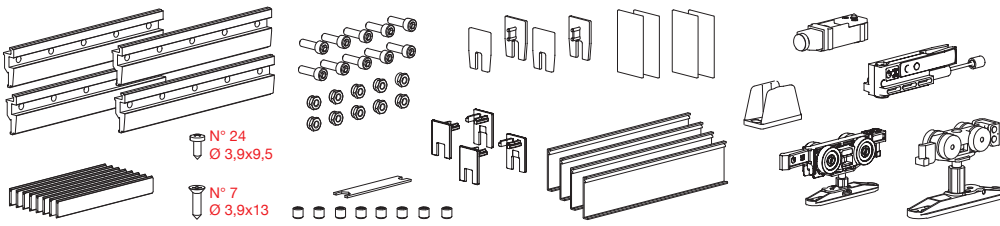

| OLD CODE | NEW CODE | | | | |
|----------|----------------------|-----------------|-----------------------------|-------------------|----|
| — | K.0164.3.C.01 | VETRO 40 | With cover Con copertura | 8-8,7 mm (5/16") | 5x |
| — | K.0165.3.C.01 | | | 10-10,7 mm (3/8") | 5x |
| — | K.0166.3.C.01 | | | 12-12,7 mm (1/2") | 5x |

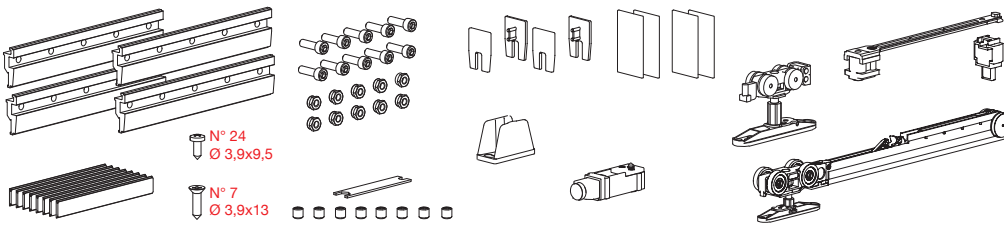

- 80 kg**
- N.1 Fluid damper
N.1 Fermo ammortizzato
FLUID Fluid
- Ball bearings
Cuscinetti a sfera
- .01** Anodized Silver
Argento

| OLD CODE | NEW CODE | | | | |
|----------|----------------------|-----------------|----------------------------------|-------------------|----|
| — | K.0164.2.S.01 | VETRO 40 | Without cover Senza copertura | 8-8,7 mm (5/16") | 4x |
| — | K.0165.2.S.01 | | | 10-10,7 mm (3/8") | 4x |
| — | K.0166.2.S.01 | | | 12-12,7 mm (1/2") | 4x |

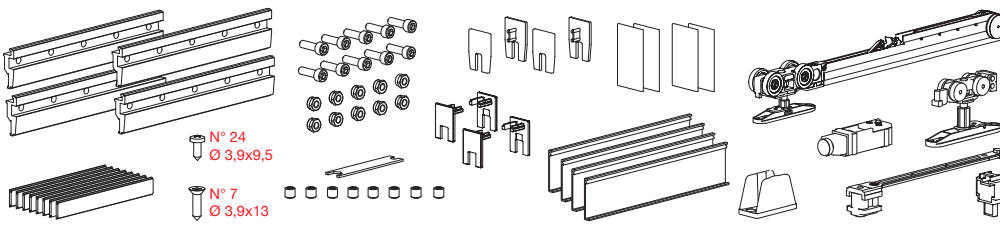

| OLD CODE | NEW CODE | | | | |
|----------|----------------------|-----------------|-----------------------------|-------------------|----|
| — | K.0164.2.C.01 | VETRO 40 | With cover Con copertura | 8-8,7 mm (5/16") | 4x |
| — | K.0165.2.C.01 | | | 10-10,7 mm (3/8") | 4x |
| — | K.0166.2.C.01 | | | 12-12,7 mm (1/2") | 4x |

MEASUREMENTS DESCRIPTION / DESCRIZIONI MISURE

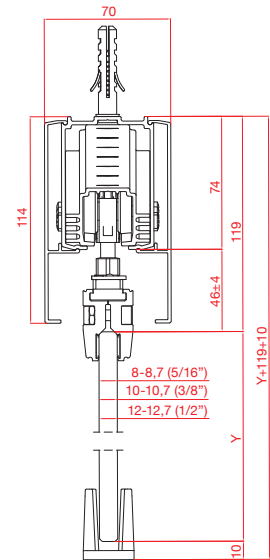
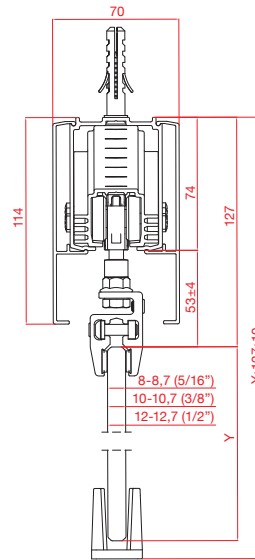
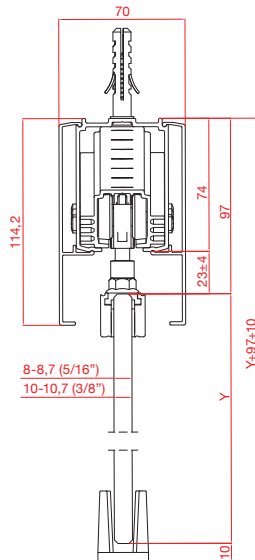
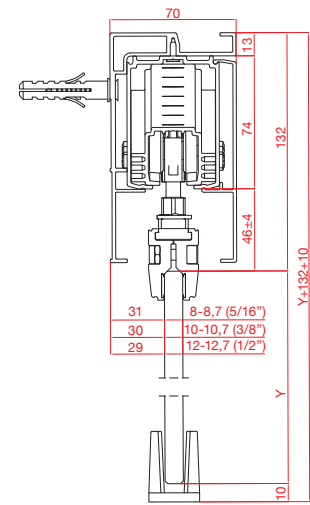
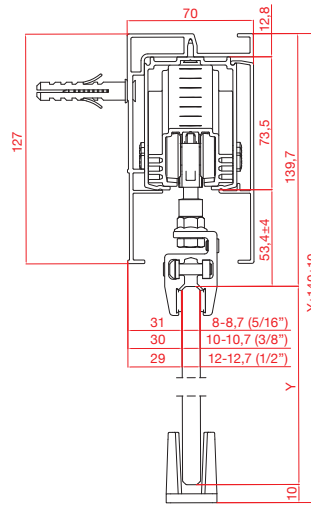
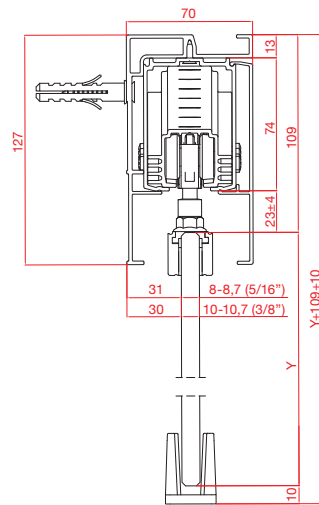

MEASUREMENTS DESCRIPTION / DESCRIZIONI MISURE

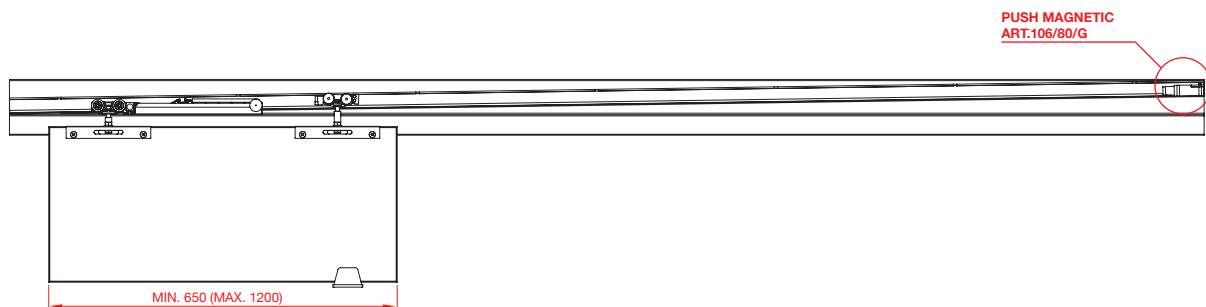

**THE SYSTEM WITH SELF CLOSING CAN BE USED IN COMBINATION WITH PUSH MAGNETIC BUMPER SYSTEM
IL SISTEMA CON CHIUSURA AUTOMATICA PUÒ ESSERE UTILIZZATO CON IL SISTEMA RESPINGENTE PUSH MAGNETIC**

| TRACK-BINARIO | MIN-MAX |
|---------------|--------------|
| L = 1600 mm | 650-800 mm |
| L = 2000 mm | 801-1000 mm |
| L = 2400 mm | 1001-1200 mm |



Selfie

Systems for doors with automatic closure
Sistemi per porte con chiusura automatica





PRIVATE

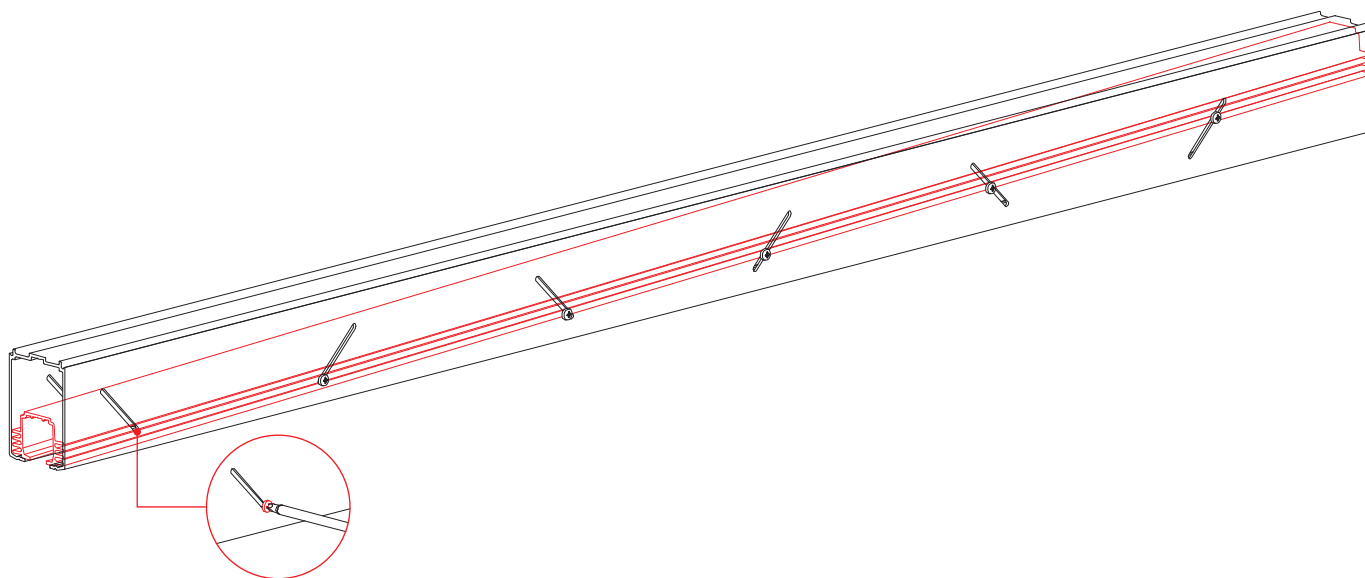

Selfie system for wooden doors it's the **innovative Terno Scorrevoli solution to realize self-closing doors without any electrical device.**

The system is available in combination with **Classic** bracket series, which integrates new **Fluid technology: the sliding motion will then result lighter and fluid, effortless.**



Il sistema Selfie per porte in legno è l'**innovativo sistema di Terno Scorrevoli per porte con chiusura automatica, che non necessita di azionamento elettrico.**

Il sistema è disponibile con staffa serie **Classic**, che integra l'innovativa **tecnologia Fluid**: il **movimento** in apertura e in chiusura risulta ancora più **leggero e fluido, senza sforzo.**

| | | | | | |
|---------------|---|---|--|---|--|
| Selfie | | COMPLETE BOX KIT / KIT COMPLETO IN SCATOLA | |  | |
| K | Complete kit for N°1 door with automatic closure / Kit completo per N°1 porta con chiusura automatica | | | | |
| | | | | | |
| | 0161 |  | Whit Classic Bracket Con staffa Classic | | |
| | | | | | |
| | | 2 | N.1 Fluid damper + N.1 Push Magnetic N.1 Fermo ammortizzato Fluid + N.1 Push Magnetic | | |
| | | | | | |
| | | | | C | With cover Con copertura |
| | | | | S | Without cover Senza copertura |
| | | | | | |
| | | | | | 01 Anodized Silver Finish Finitura Argento |

EXAMPLE / ESEMPIO

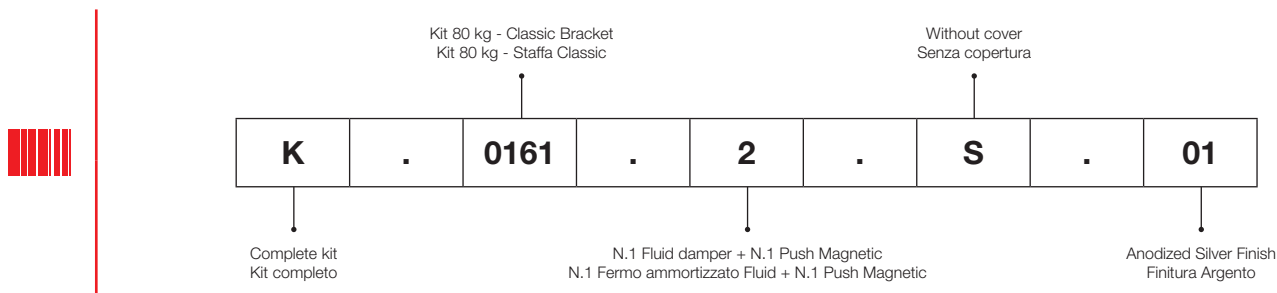

| | | | | | |
|------------------------|---|---|--|---|-----------------|
| Tracks / Binari | | ALUMINUM FINISHES CODES / CODICI FINITURE ALLUMINIO | |  | |
| CODE / CODICE | | FINISH COLOR / COLORE FINITURA | | | |
| 8 01 0.0 |  | 01 A | Anodized Silver / Argento | | STANDARD |
| 8 02 0.0 |  | 02 AS | Brushed Anodized Silver / Argento Spazzolato | | |

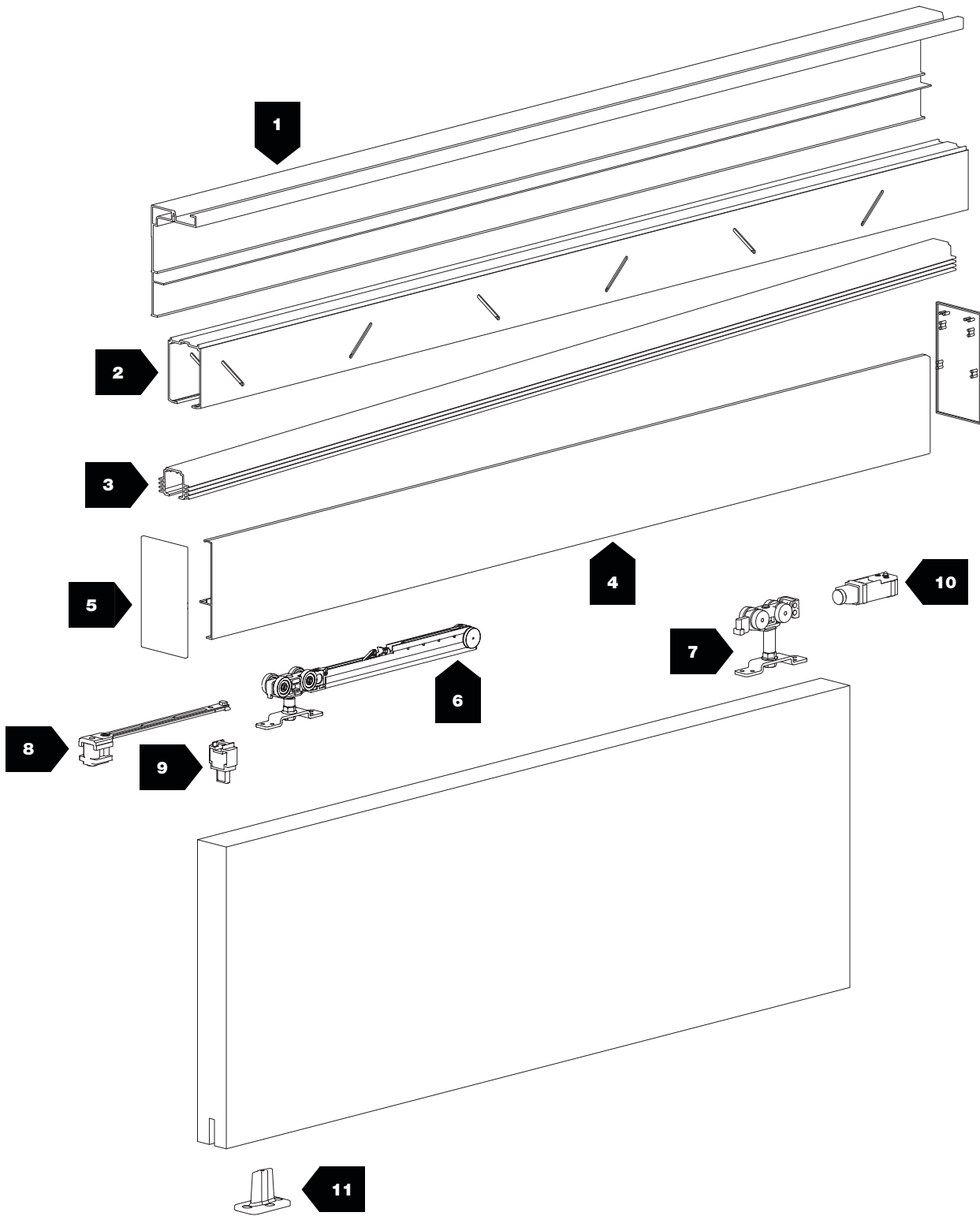





Max 45 mm



Max 80 kg

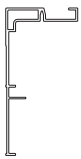
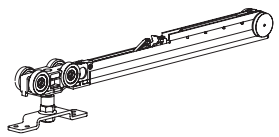

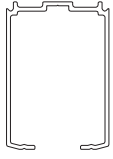
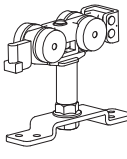
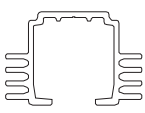
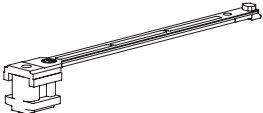
Min. 650 - Max. 1200 mm

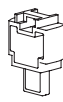
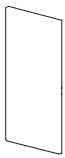
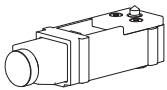
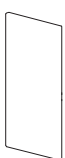
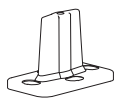
| N° | Barcode | | kg | | N° | Barcode | | kg | |
|----|---|---|----|--|----|----------|---|----|--|
| 1 | 2430 8 01 0.02430 |  | — | | 6 | 2415/080 |  | 80 |  NEW |
| 2 | 2410 S.2410/A/1600 S.2410/A/2000 S.2410/A/2400 |  | — | | 7 | 2403 |  | 80 | |
| 3 | 2400 S.2400/A/1600 S.2400/A/2000 S.2400/A/2400 |  | — | | 8 | 3354 |  | 80 |  NEW |
| 4 | 2420 8 02 0.02420 |  | — | | 9 | 3347 |  | — | |
| 5 | 2412 |  | — | | 10 | 106/80/G |  | 80 | |
| | 2414 |  | — | | 11 | 2406 |  | 80 | |

-  N.1 Fluid damper
N.1 Fermo ammortizzato
Fluid
-  Ball bearings
Cuscinetti a sfera
-  Anodized Silver
Argento

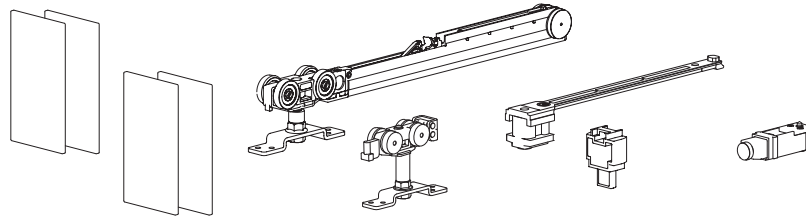

-  N° 24
Ø 3,9x9,5
-  N° 7
Ø 3,9x13
- 

| OLD CODE | NEW CODE | COLORS / COLORI |  |  |  |
|----------|----------------------|---------------------------|---|---|---|
| — | K.0161.2.S.01 | Anodized Silver / Argento | 80 kg | Max 45 mm | 4x |

MEASUREMENTS DESCRIPTION / DESCRIZIONI MISURE

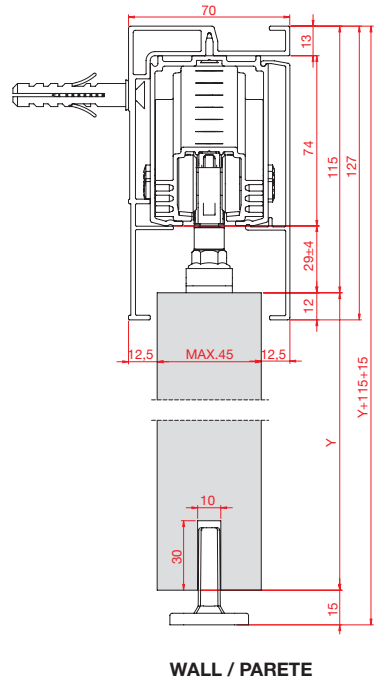
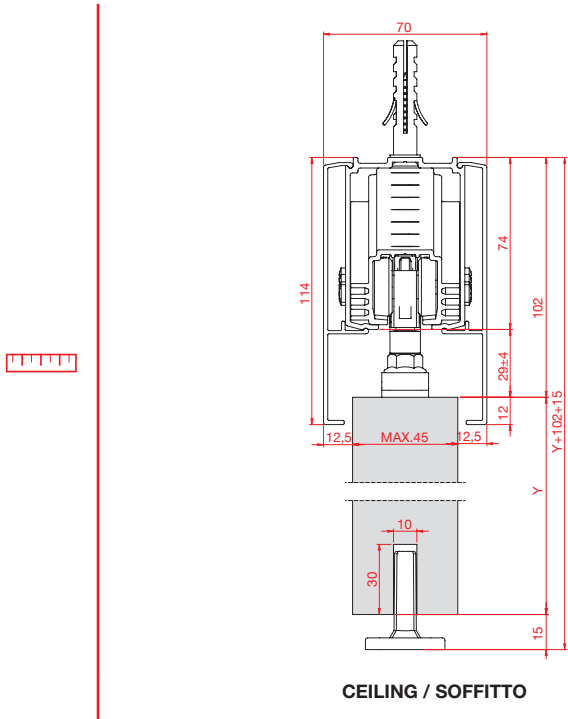

MEASUREMENTS DESCRIPTION / DESCRIZIONI MISURE

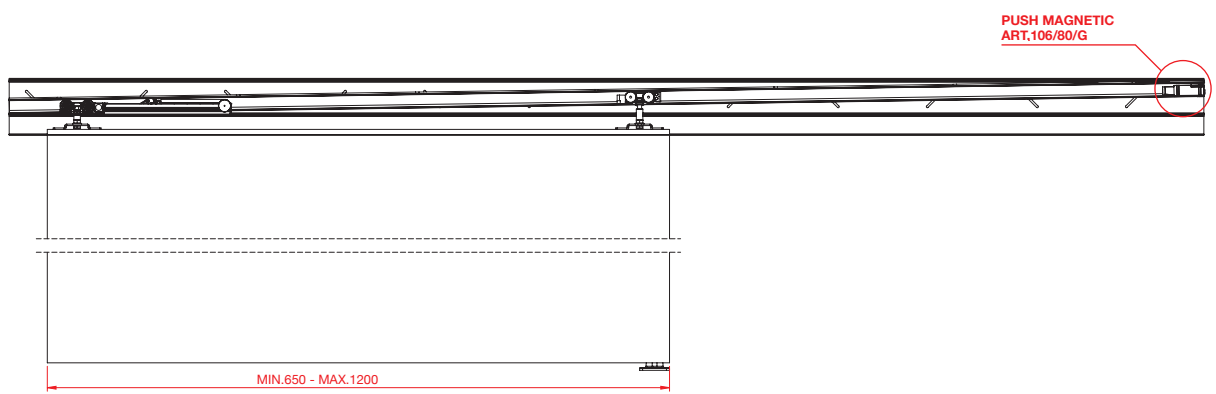

**THE SYSTEM WITH SELF CLOSING CAN BE USED IN COMBINATION WITH PUSH MAGNETIC BUMPER SYSTEM
IL SISTEMA CON CHIUSURA AUTOMATICA PUÒ ESSERE UTILIZZATO CON IL SISTEMA RESPINGENTE PUSH MAGNETIC**

|  TRACK-BINARIO |  MIN-MAX |
|---|---|
| L = 1600 mm | 650-800 mm |
| L = 2000 mm | 801-1000 mm |
| L = 2400 mm | 1001-1200 mm |



Solo Vetro

Concealed sliding elements integrated into the aluminium sliding tracks
Scorrevoli invisibili integrati nei profili di scorrimento in alluminio





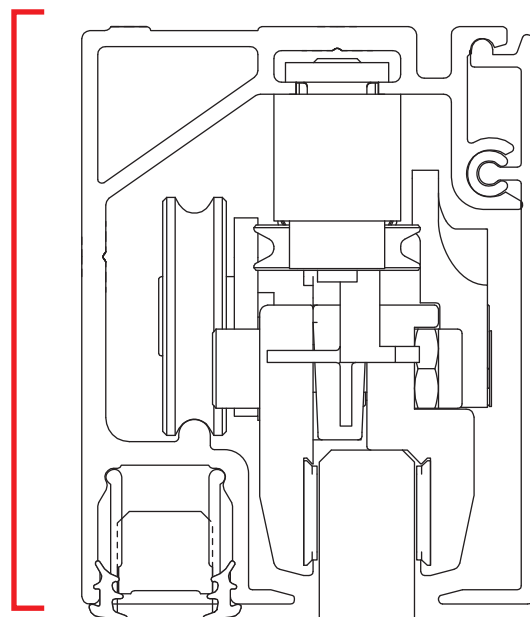

Concealed sliding clamps

Solo Vetro is a sliding system with profile integrated sliding clamps, dedicated to frameless glass doors.

Sliding clamps are **totally concealed from aluminium profiles**, in order to grant a better aesthetic result.

The system has been designed to allow configurations of **single and double doors, with synchronized motion**.

Solo Vetro is suitable to monolithic and laminated glasses.



Scorrevoli invisibili

Solo Vetro è il sistema di scorrevoli invisibili, realizzato per porte interamente in vetro.

Gli **scorrevoli**, infatti, sono **completamente nascosti dai profili in alluminio**, per una migliore resa estetica del sistema.

Il sistema prevede la configurazione sia per l'**apertura singola** che per l'**apertura simultanea sincronizzata**.

Solo Vetro è stato progettato per l'utilizzo di vetri monolitici o stratificati.

| Solo Vetro | | COMPLETE BOX KIT / KIT COMPLETO IN SCATOLA | |  |
|-------------------|-----------------------------|--|--|---|
| K | Complete kit / Kit completo | | | |
| | | | | |
| | | 0271 |  Solo Vetro Sync Simultaneous opening / Apertura simultanea | |
| | | 0272 |  Solo Vetro | |
| | | | | |
| | | | | 5 N.2 Soft damper stoppers N.2 Fermi ammortizzati |

EXAMPLE / ESEMPIO

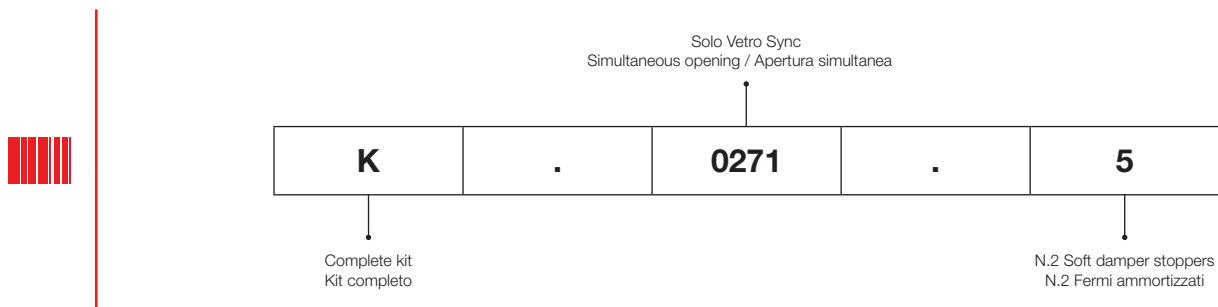

| Tracks / Binari | | ALUMINUM FINISHES CODES / CODICI FINITURE ALLUMINIO | |  |
|------------------------|---|---|--|---|
| CODE / CODICE | FINISH COLOR / COLORE FINITURA | | | |
| 8 01 0.0 |  | 01 A | Anodized Silver / Argento | STANDARD |
| 8 02 0.0 |  | 02 AS | Brushed Anodized Silver / Argento Spazzolato | |

Solo Vetro

Concealed sliding elements integrated into the aluminium sliding tracks
Scorrevoli invisibili integrati nei profili di scorrimento in alluminio

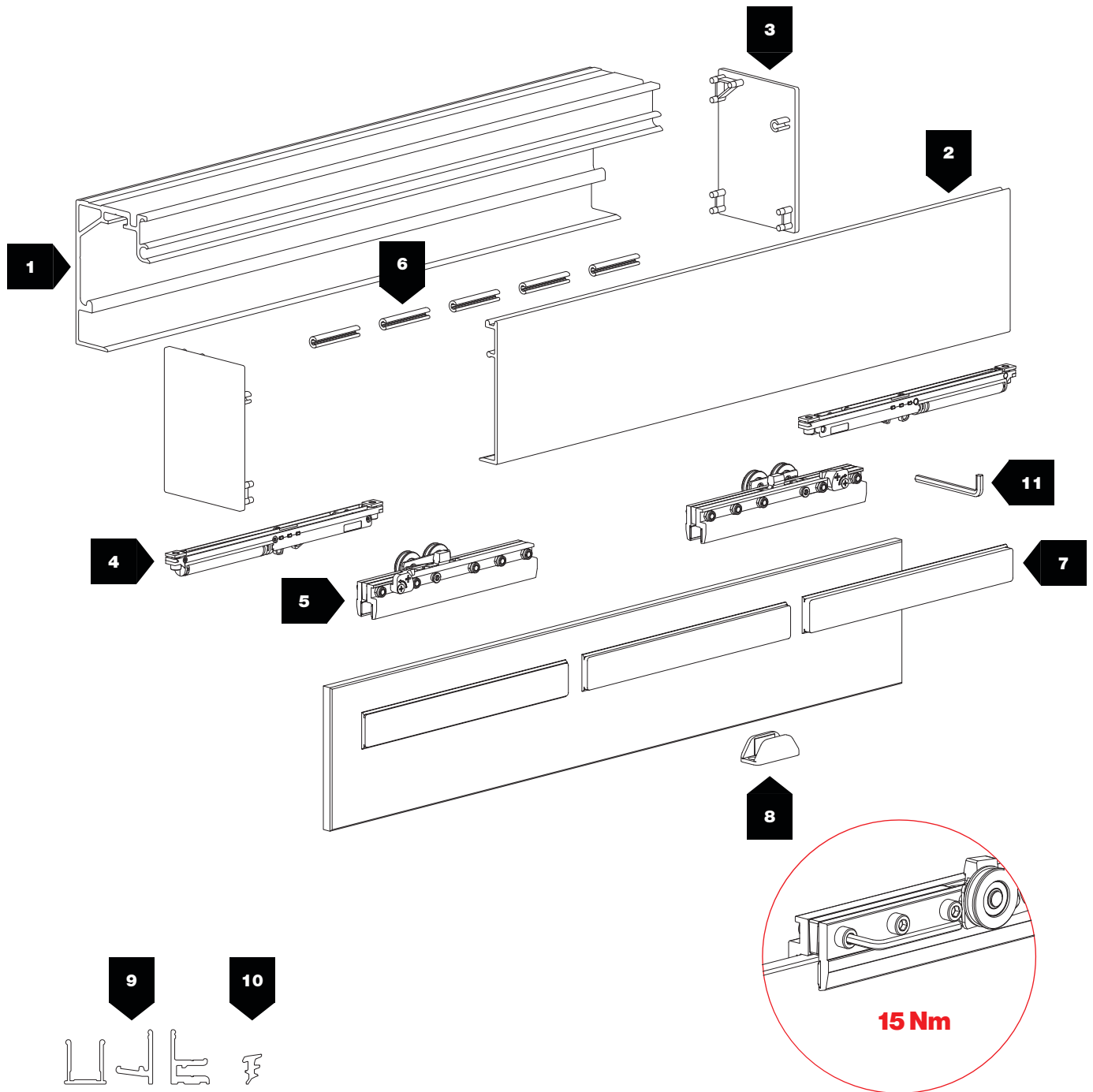



8-8,7 ÷ 12-12,7 mm

80 kg

N° 1 door / N° 1 porta

| N° | Barcode | | kg | | N° | Barcode | | kg | | |
|----|----------------------|--|----|---|----|---------|----------------------|----|---|---|
| 1 | 2710 8 02 0.02710 | | - | | 8 | 1486/12 | | 80 | Glass thk. Vetri sp. 12-12,7 mm (1/2") | |
| | 2720 8 02 0.02720 | | - | | | 1488 | | 80 | Glass thk. Vetri sp. 8-8,7 mm ÷ 12-12,7 mm (5/16" ÷ 1/2") | |
| 2 | 2730 8 02 0.02730 | | - | | | 1489/8 | | 80 | Glass thk. Vetri sp. 8-8,7 mm (5/16") | |
| 3 | 2716 | | - | | | 1489/10 | | 80 | Glass thk. Vetri sp. 10-10,7 mm (3/8") | |
| | 2718 | | - | | | 1489/12 | | 80 | Glass thk. Vetri sp. 12-12,7 mm (1/2") | |
| 4 | 2061 | | 80 | | | 9 | 2740 8 01 0.02740 | | - | |
| 5 | 2700/2 | | 80 | | | | 1776 8 01 0.01776 | | - | |
| 6 | 1222 | | - | | | | 1774 8 01 2.01774 | | - | |
| 7 | 1707 | | - | Glass thk. Vetri sp. 8-8,7 mm (5/16") | | 10 | 328 | | - | Glass thk. Vetri sp. 8-8,7 mm (5/16") |
| | 1704 | | - | Glass thk. Vetri sp. 10-10,7 mm (3/8") | | | 326 | | - | Glass thk. Vetri sp. 10-10,7 mm (3/8") |
| | 1705 | | - | Glass thk. Vetri sp. 12-12,7 mm (1/2") | | | 324 | | - | Glass thk. Vetri sp. 12-12,7 mm (1/2") |
| 8 | 1486/8 | | 80 | Glass thk. Vetri sp. 8-8,7 mm (5/16") | 11 | 2088 | | - | | |
| | 1486/10 | | 80 | Glass thk. Vetri sp. 10-10,7 mm (3/8") | | | | | | |

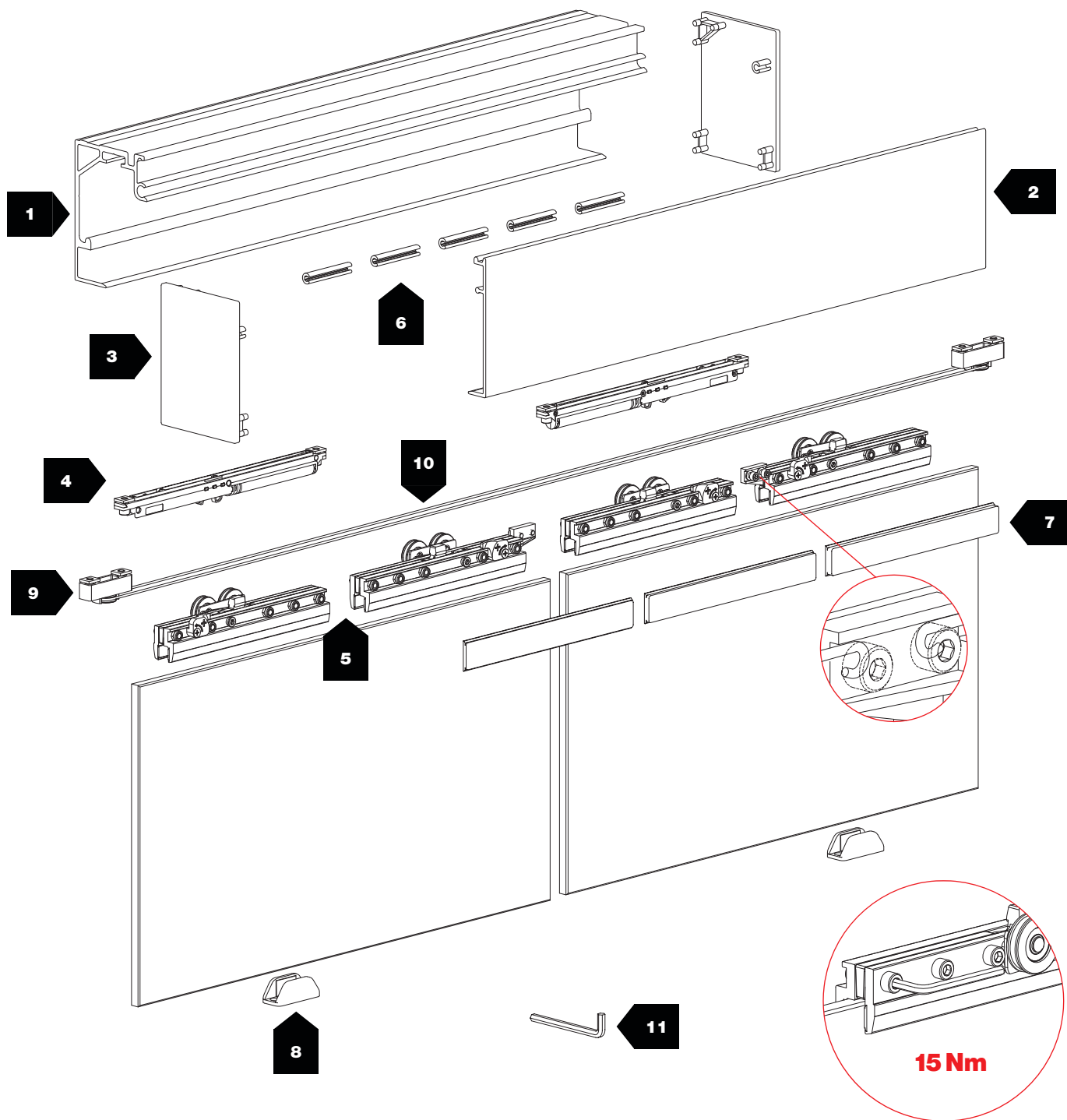
SYNC SIMULTANEOUS OPENING / APERTURA SIMULTANEA



8-8,7 ÷ 12-12,7 mm



80 kg



Simultaneous opening / Apertura simultanea

| N° | Barcode | | kg | | N° | Barcode | | kg | | |
|----|----------------------|----|----|---|----|---------|------|----|--|---|
| 1 | 2710 8 02 0.02710 | | — | | 8 | 1486/8 | | 80 | Glass thk. Vetri sp. 8-8,7 mm (5/16") | |
| | 2720 8 02 0.02720 | | — | | | 1486/10 | | 80 | Glass thk. Vetri sp. 10-10,7 mm (3/8") | |
| 2 | 2730 8 02 0.02730 | | — | | | 1486/12 | | 80 | Glass thk. Vetri sp. 12-12,7 mm (1/2") | |
| 3 | 2716 | | — | | | 1488 | | 80 | Glass thk. Vetri sp. 8-8,7 mm ÷ 12-12,7 mm (5/16"÷1/2") OPTIONAL + | |
| | 2718 | | — | | | 1489/8 | | 80 | Glass thk. Vetri sp. 8-8,7 mm (5/16") OPTIONAL + | |
| 4 | 2061 | | 80 | | | 1489/10 | | 80 | Glass thk. Vetri sp. 10-10,7 mm (3/8") OPTIONAL + | |
| 5 | 2700/2 | | 80 | | | 1489/12 | | 80 | Glass thk. Vetri sp. 12-12,7 mm (1/2") OPTIONAL + | |
| | 2702/2 | | 80 | | | 9 | 2714 | | — | |
| 6 | 1222 | | — | | | 7 | 1707 | | — | Glass thk. Vetri sp. 8-8,7 mm (5/16") |
| 7 | 1704 | | — | | | | 1704 | | — | Glass thk. Vetri sp. 10-10,7 mm (3/8") |
| | 1705 | | — | | | | 1705 | | — | Glass thk. Vetri sp. 12-12,7 mm (1/2") |
| | 10 | 88 | | — | 11 | 2088 | | — | | |

Solo Vetro

Concealed sliding elements integrated into the aluminium sliding tracks
 Scorrrevoli invisibili integrati nei profili di scorrimento in alluminio

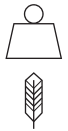

80 kg

N.2 Soft damper stoppers
 N.2 Fermi ammortizzati

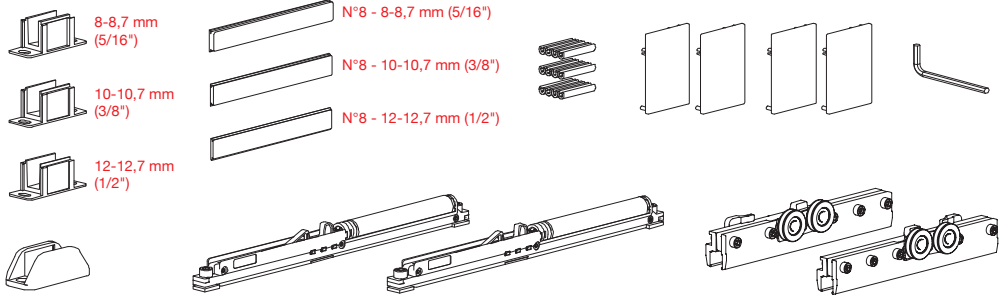

| OLD CODE | NEW CODE |  MIN |
|-------------|----------|---|
| 2700/2119/A | K.0272.5 | 4x |



80 kg

N.2 Soft damper stoppers
 N.2 Fermi ammortizzati

SYNC



Simultaneous opening
 Apertura simultanea

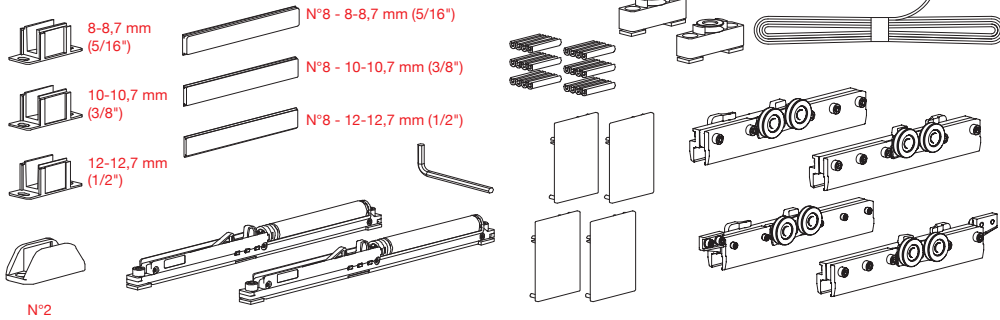

| OLD CODE | NEW CODE |  MIN |
|---------------|----------|---|
| 2702/2/2714/A | K.0271.5 | 4x |

MEASUREMENTS DESCRIPTION / DESCRIZIONI MISURE

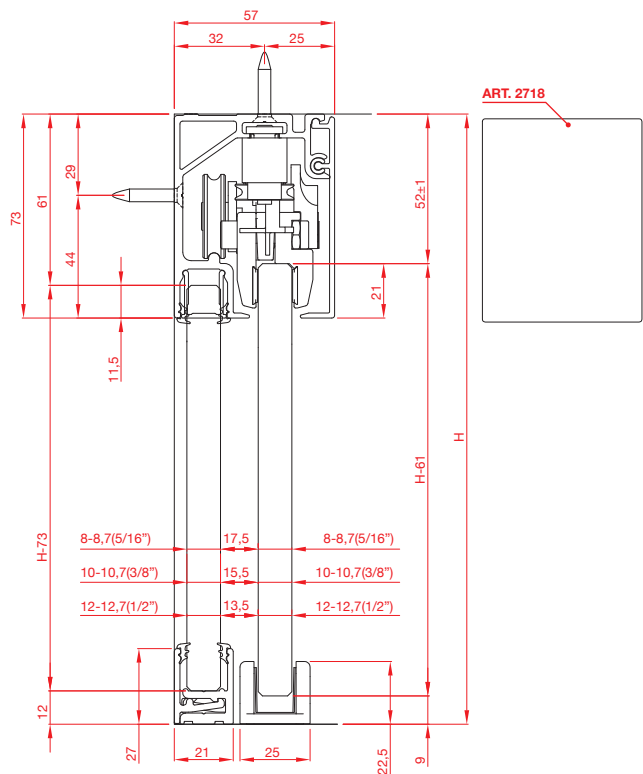
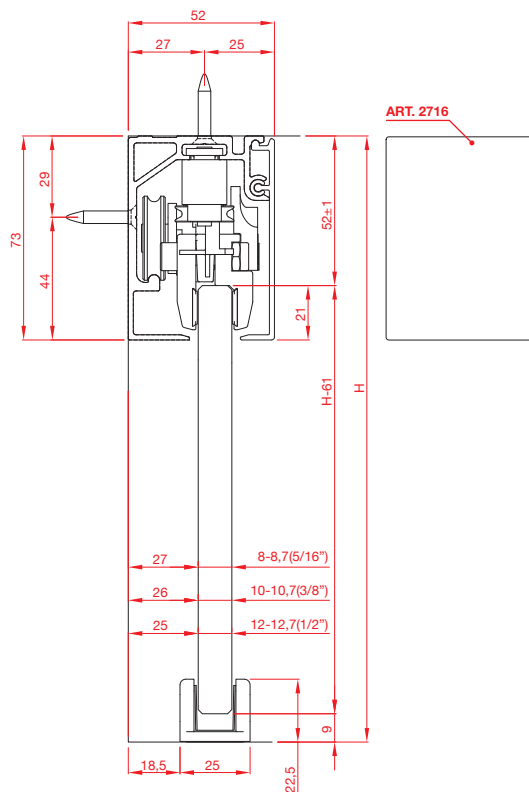



Solo Vetro Light

Concealed sliding elements for plasterboard walls
Sistema di scorrevoli invisibili per pareti in cartongesso





Concealed sliding system dedicated to false ceiling frameless glass doors

Solo Vetro Light is a **concealed sliding system** dedicated to false ceiling frameless glass doors.

Sliding clamps are totally concealed from built-in aluminium profiles, in order to grant a better aesthetic result.

Solo Vetro Light is suitable to monolithic and laminated glasses.

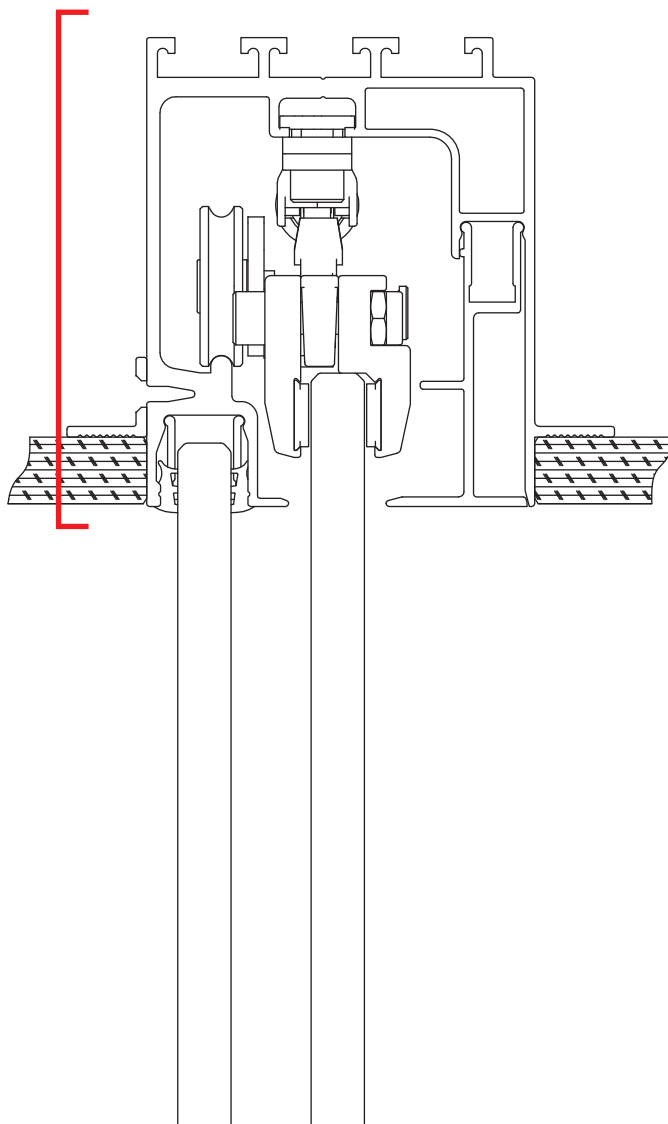

Scorrevoli invisibili per porte in vetro applicabili a controsoffitti



Solo Vetro Light è il **sistema di scorrevoli** realizzato per porte interamente in vetro **applicabili a controsoffitti**.

Gli scorrevoli sono integrati nei profili in alluminio, per una migliore resa estetica del sistema.

Solo Vetro Light è stato progettato per l'utilizzo di vetri monolitici o stratificati.

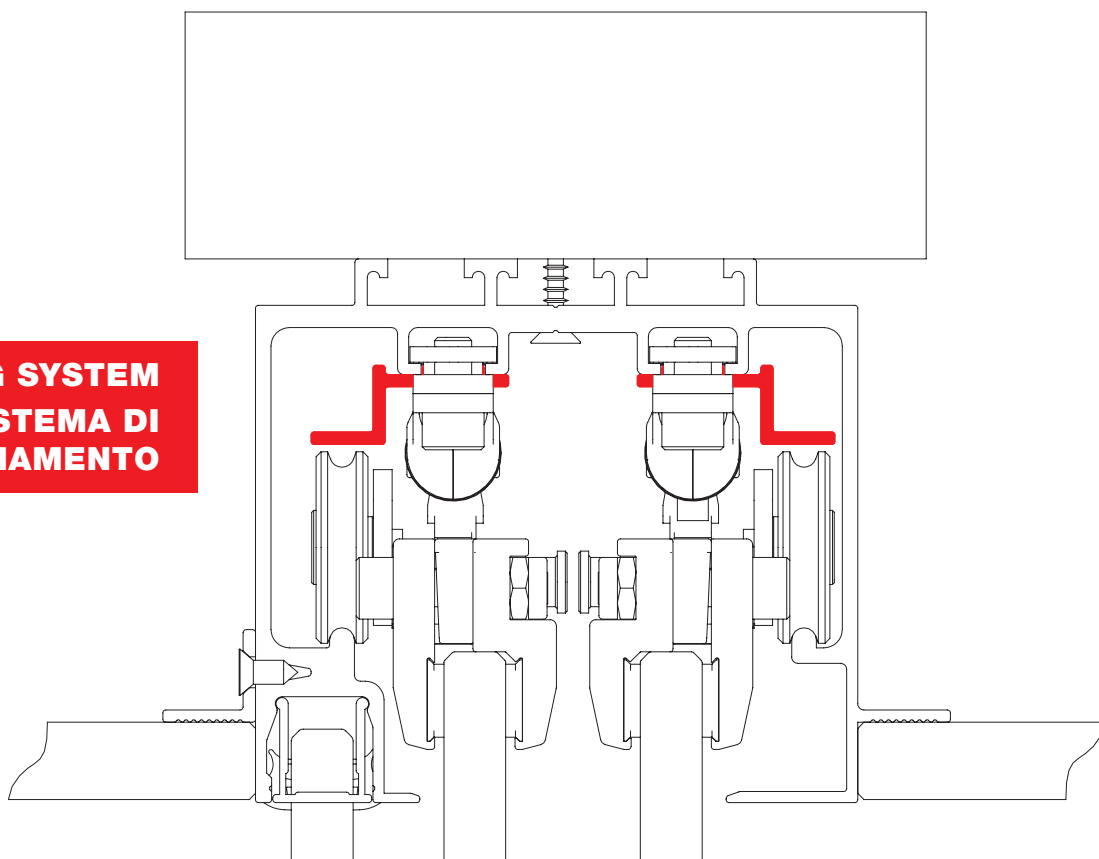
ANTI-JUMPING SYSTEM SISTEMA DI ANTISGANCIAMENTO



| Solo Vetro Light | | COMPLETE BOX KIT / KIT COMPLETO IN SCATOLA | |  |
|-------------------------|-----------------------------|--|---|---|
| K | Complete kit / Kit completo | | | |
| | | 0281 |  | Solo Vetro Light |
| | | | | |
| | | | 5 | N.2 Soft damper stoppers N.2 Fermi ammortizzati |

EXAMPLE / ESEMPIO

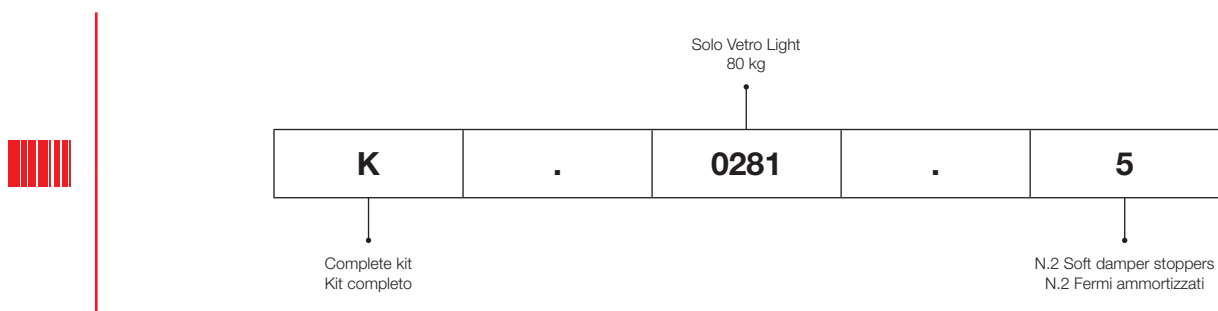

| Tracks / Binari | | ALUMINUM FINISHES CODES / CODICI FINITURE ALLUMINIO | |  |
|------------------------|---|---|-----------------|---|
| CODE / CODICE | | FINISH COLOR / COLORE FINITURA | | |
| 8 01 0.0 |  01 A | Anodized Silver / Argento | STANDARD | |

Solo Vetro Light

Concealed sliding elements for plasterboard walls
Sistema di scorrevoli invisibili per pareti in cartongesso

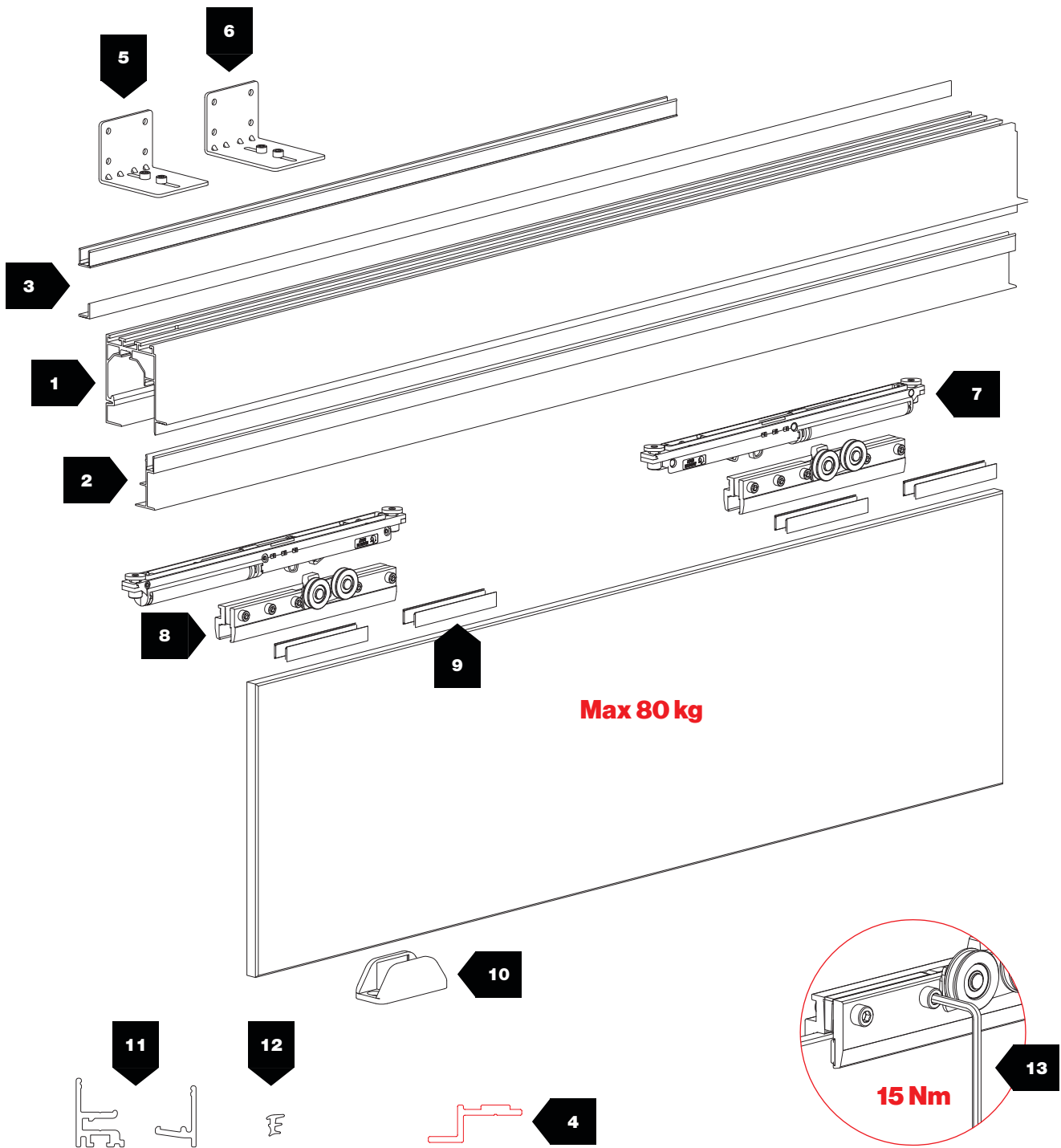

8-8,7 ÷ 12-12,7 mm



Max 80 kg

N° 1 door / N° 1 porta

| N° | Barcode | | kg | | N° | Barcode | | kg | |
|----------------------|----------------------|----|---|---------|----------------------|---------|----|---|---|
| 1 | 2250 8 01 0.02250 | | — | | 9 | 1707 | | — | Glass thk. Vetri sp. 8-8,7 mm (5/16") |
| | 2256 8 01 0.02256 | | — | | | 1704 | | — | Glass thk. Vetri sp. 10-10,7 mm (3/8") |
| | 2258 8 01 0.02258 | | — | | | 1705 | | — | Glass thk. Vetri sp. 12-12,7 mm (1/2") |
| | 2259 8 01 0.02259 | | — | | 10 | 1486/8 | | 80 | Glass thk. Vetri sp. 8-8,7 mm (5/16") |
| 2254 8 01 0.02254 | | — | Combined with Art.2250 & Art.2256 Abbinare ad Art.2250 e Art.2256 | 1486/10 | | | 80 | Glass thk. Vetri sp. 10-10,7 mm (3/8") | |
| 2740 8 01 0.02740 | | — | | 1486/12 | | | 80 | Glass thk. Vetri sp. 12-12,7 mm (1/2") | |
| 2252 8 01 0.02252 | | — | OPTIONAL + | 1489/8 | | | 80 | Glass thk. Vetri sp. 8-8,7 mm (5/16") | |
| 2260 8 01 0.02260 | | — | Mandatory with Art.2258 & Art.2259 Tassativo con Art.2258 e Art.2259 | 1489/10 | | | 80 | Glass thk. Vetri sp. 10-10,7 mm (3/8") | |
| 157 | | 80 | | 1489/12 | | | 80 | Glass thk. Vetri sp. 12-12,7 mm (1/2") | |
| 138 | | 80 | | 11 | 1776 8 01 0.01776 | | — | | |
| 2056 | | 80 | | | 1774 8 01 2.01774 | | — | | |
| 2251/2 | | 80 | | 12 | 328 | | — | Glass thk. Vetri sp. 8-8,7 mm (5/16") | |
| | | | | | 326 | | — | Glass thk. Vetri sp. 10-10,7 mm (3/8") | |
| | | | | | 324 | | — | Glass thk. Vetri sp. 12-12,7 mm (1/2") | |
| | | | | 13 | 2088 | | — | | |

Solo Vetro Light

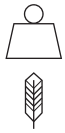
Concealed sliding elements for plasterboard walls
Sistema di scorrevoli invisibili per pareti in cartongesso



Max 80 kg

N.2 Soft damper stoppers
N.2 Fermi ammortizzati

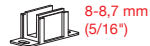

8-8,7 mm
(5/16")



10-10,7 mm
(3/8")



12-12,7 mm
(1/2")



8-8,7 mm
(5/16")



10-10,7 mm
(3/8")



12-12,7 mm
(1/2")

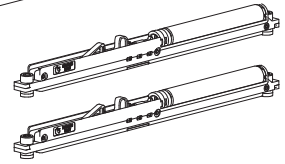
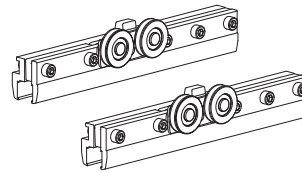
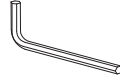

| OLD CODE | NEW CODE |  MIN |
|---------------|----------|---|
| 2700/2/2061/A | K.0281.5 | 4x |

MEASUREMENTS DESCRIPTION / DESCRIZIONI MISURE

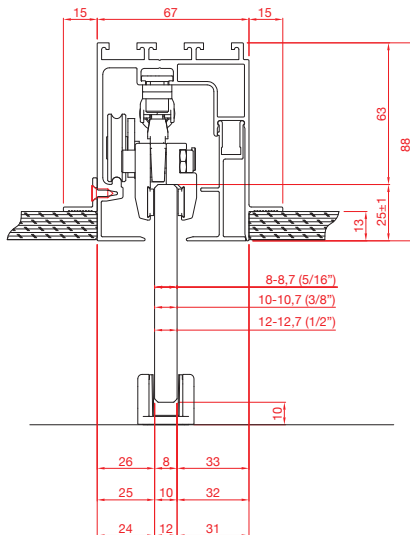

SINGLE DOOR / PORTA SINGOLA

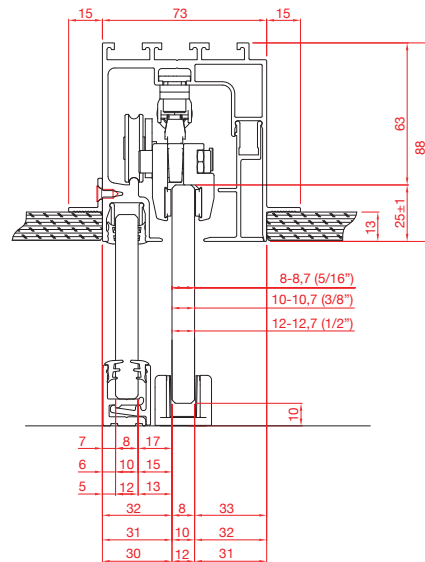

SINGLE DOOR + FIXED GLASS / PORTA SINGOLA + FISSO

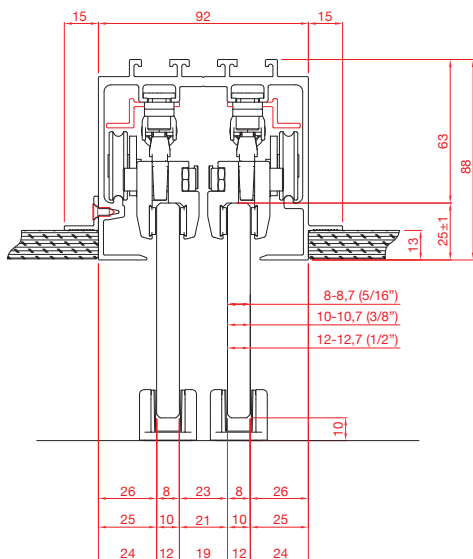

DOUBLE DOOR / PORTA DOPPIA

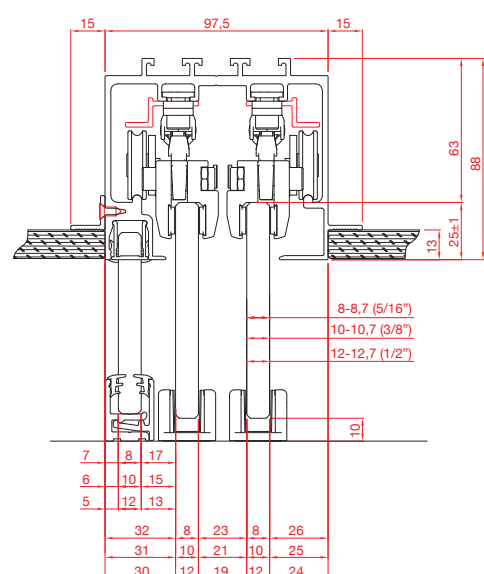

DOUBLE DOOR + FIXED GLASS / PORTA DOPPIA + FISSO

FASTENING SYSTEM / SISTEMA DI FISSAGGIO

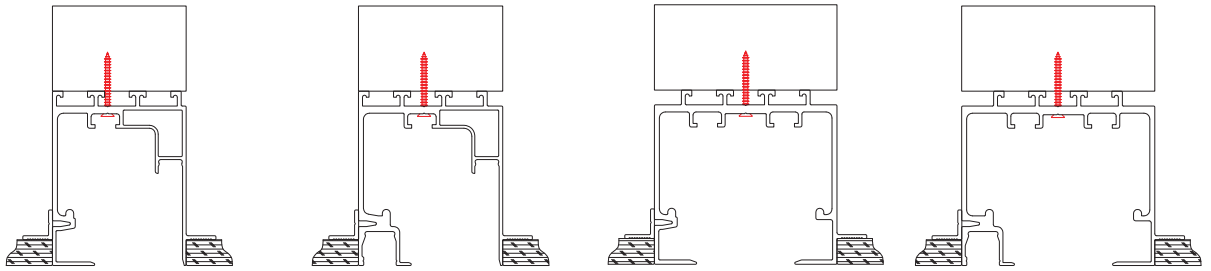

REAL CEILING / SOFFITTO PIENO

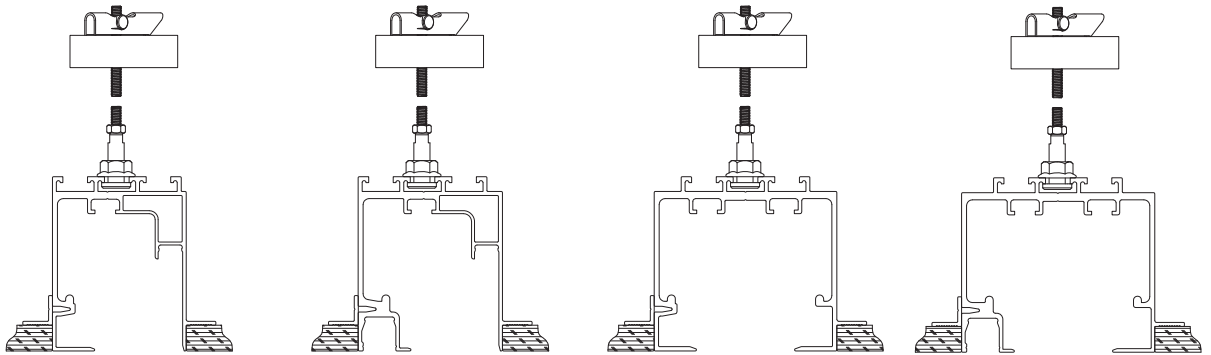

FALSE CEILING / SOFFITTO VUOTO

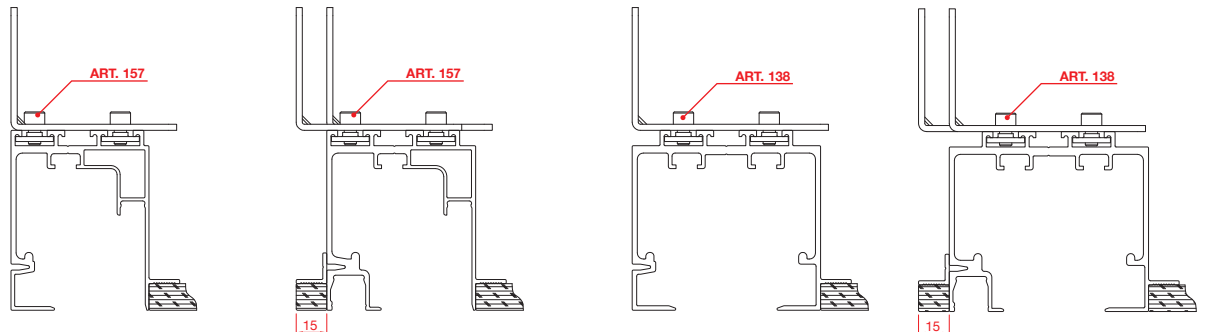

WALL / PARETE

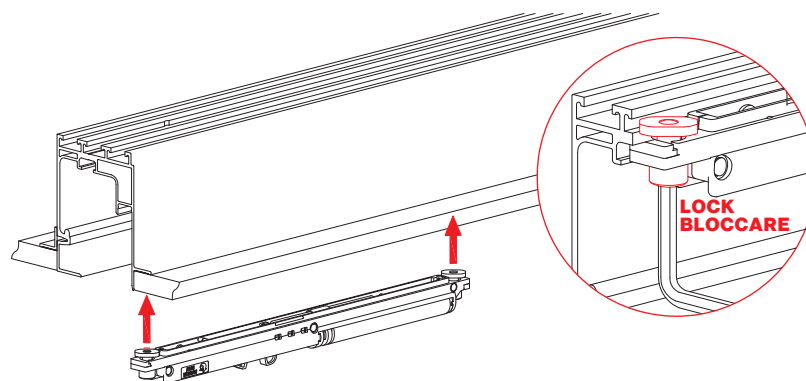

SOFT DAMPER STOPPER INSTALLATION / MONTAGGIO FERMO

FOR FIXING USE ART. 2304 - 2306 - 2308/3 (PAG. 110)
PER IL FISSAGGIO UTILIZZARE GLI ART. 2304 - 2306 - 2308/3 (PAG. 110)



Step

Automatic frontal bracket system
Scorrevoli con staffa automatica frontale





Slides with frontal automatic clamp
Scorrevoli con staffa automatica frontale

A

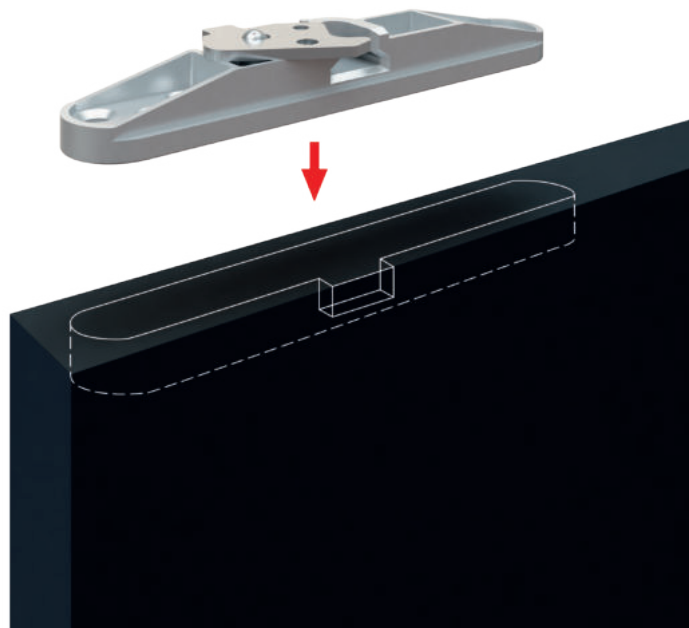
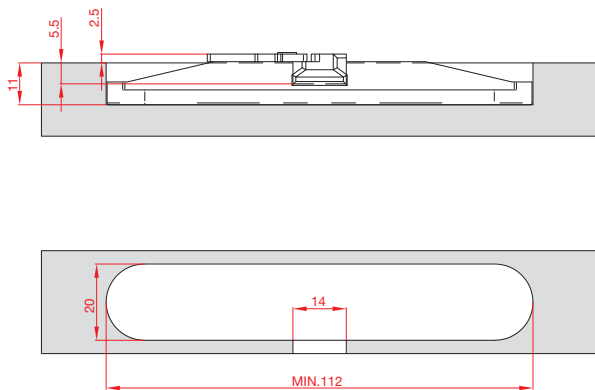

B

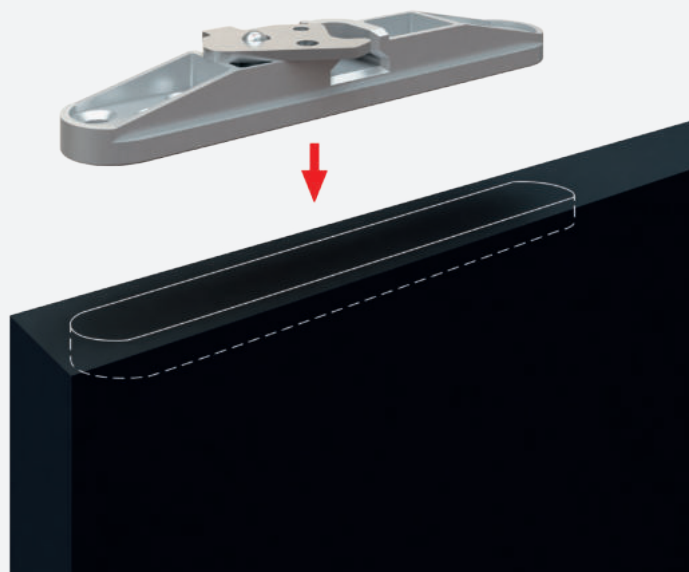
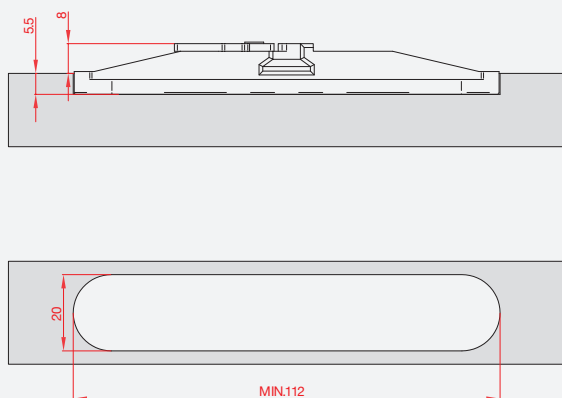

C

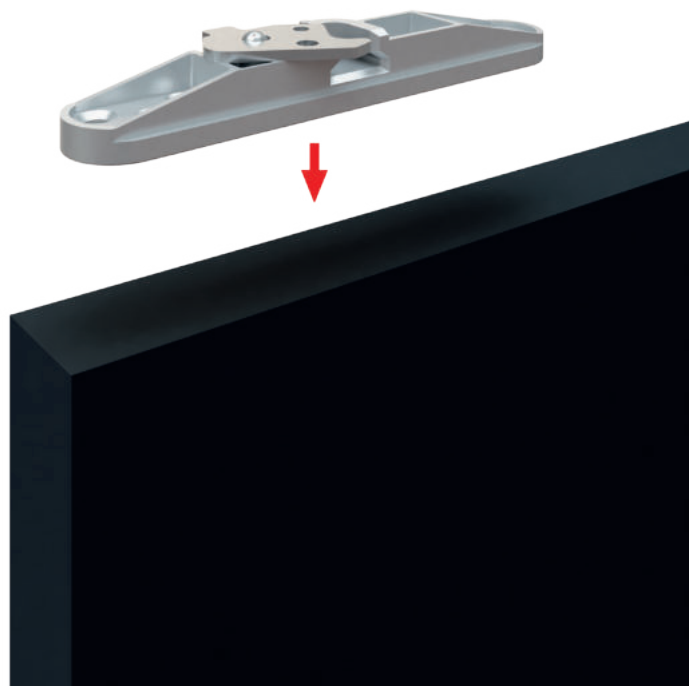
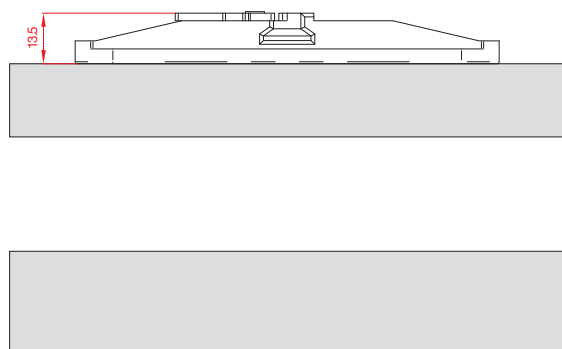

Easy mounting Facile da montare

1

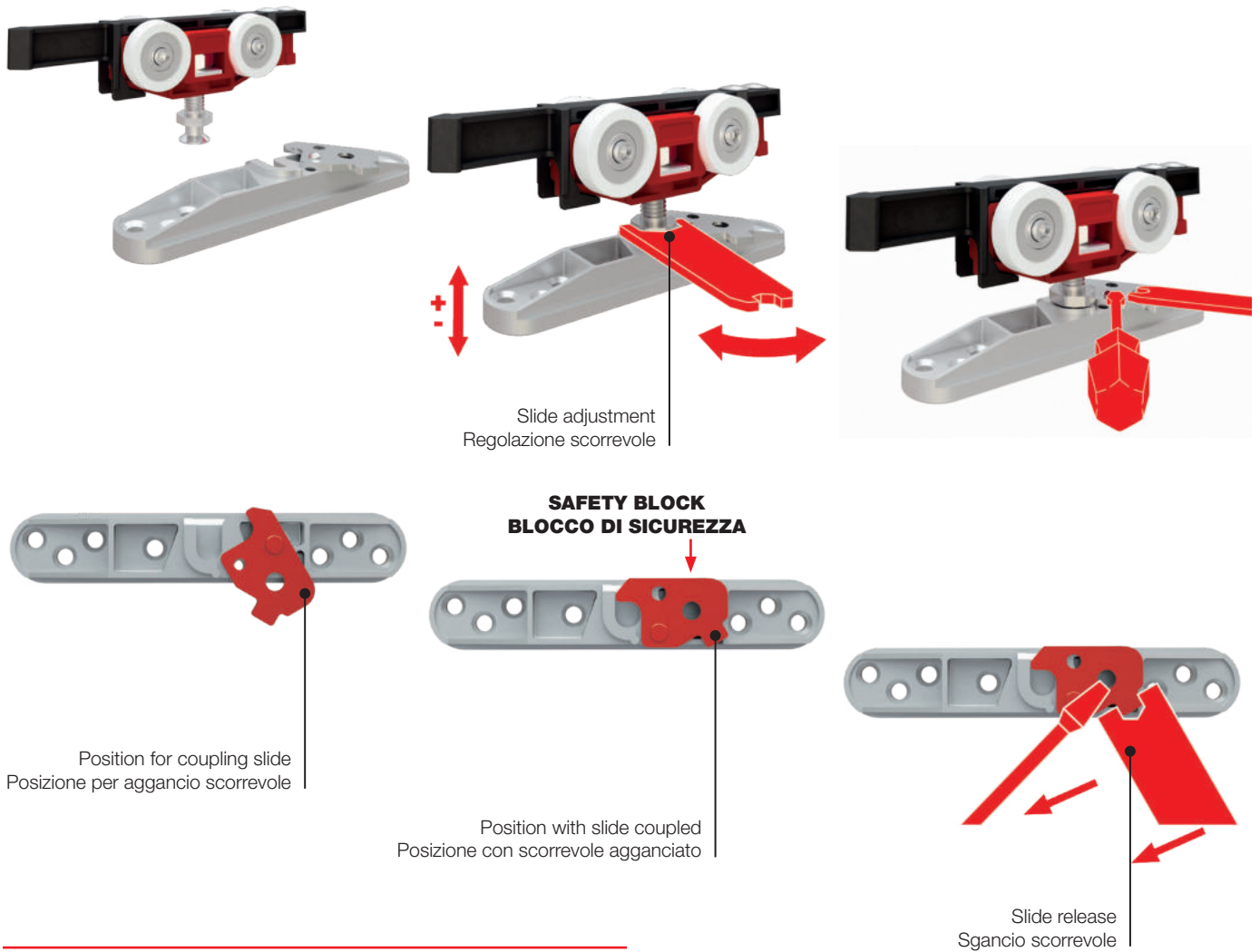

2



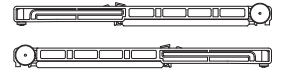
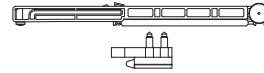





















**N.2 STANDARD STOPPERS
N.2 FERMI STANDARD**

**N.1 SOFT DAMPER STOPPER +
N.1 STANDARD STOPPER
N.1 FERMO AMMORTIZZATO +
N.1 FERMO STANDARD**

**N.2 SOFT DAMPER STOPPERS
N.2 FERMI AMMORTIZZATI**

| | | | |
|--|---|--|---|
|  <p>30 kg</p> |   <p>Min. 600 mm</p> <p>PAG. 12</p> |   <p>Min. 600 mm</p> <p>PAG. 12</p> |   <p>Min. 600 mm</p> <p>PAG. 12</p> |
|  <p>50 kg</p> | | | |
|  <p>80 kg</p> |   <p>Min. 600 mm</p> <p>PAG. 15</p> | | |
|  <p>120 kg</p> | | | |
|  <p>160 kg</p> |   <p>Min. 700 mm</p> <p>PAG. 17</p> | | |
|  <p>180 kg</p> | | | |
|  <p>240 kg</p> |   <p>Min. 700 mm</p> <p>PAG. 18</p> | | |
|  <p>250 kg</p> | | | |

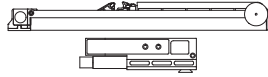
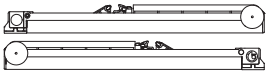

N.2 FLUID DAMPERS
N.2 FERMI AMMORTIZZATI FLUID

N.1 FLUID DAMPER + N.1 SHOCK ABSORBER
N.1 FERMO AMMORTIZZATO FLUID + N.1 FERMO A PINZA AMMORTIZZATO

N.2 SHOCK ABSORBERS
N.2 FERMI A PINZA AMMORTIZZATI

N.2 HYDRAULIC STOPPERS (NAVAL SECTOR)
N.2 FERMI IDRAULICI (SETTORE NAVALE)

| | | | |
|------------------------|------------------------|------------------------|----------------|
| | | | |
| ● | ● | ● | |
| NEW Min. 740 mm | NEW Min. 600 mm | NEW Min. 600 mm | |
| PAG. 13 | PAG. 13 | PAG. 13 | |
| ● | ● | ● | ● |
| NEW Min. 740 mm | NEW Min. 600 mm | NEW Min. 600 mm | Min. 700 mm |
| PAG. 14 | PAG. 14 | PAG. 14 | PAG. 15 |
| ● | ● | ● | |
| NEW Min. 740 mm | NEW Min. 600 mm | NEW Min. 600 mm | |
| PAG. 16 | PAG. 16 | PAG. 16 | |
| | | ● | |
| | | NEW Min. 700 mm | |
| | | PAG. 17 | |
| | | ● | |
| | | NEW Min. 700 mm | |
| | | PAG. 18 | |

Step Automatic frontal bracket system
Scorrevoli con staffa automatica frontale

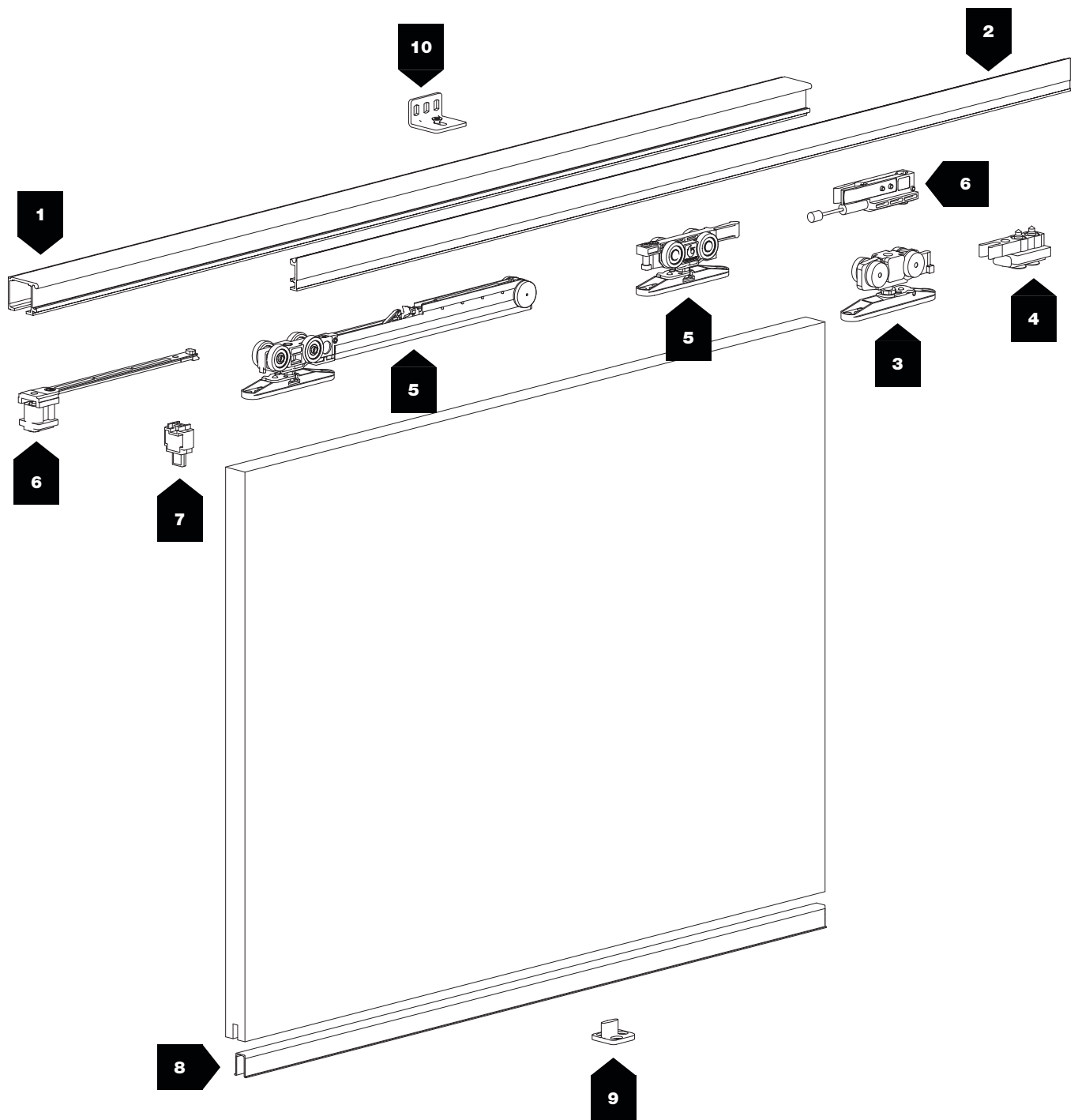

600 ÷ 1500 mm



30 ÷ 250 kg











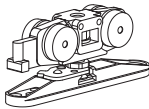
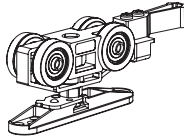
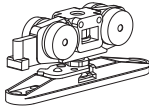
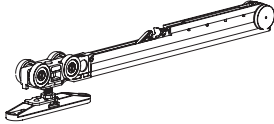
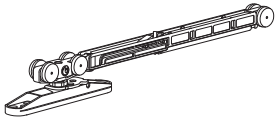
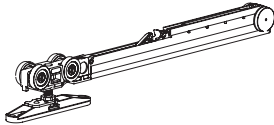

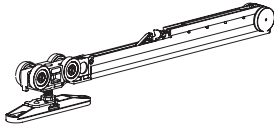
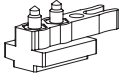
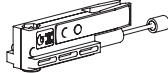
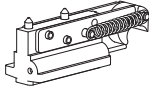
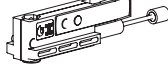
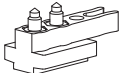
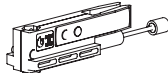
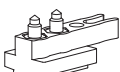
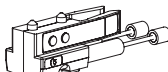

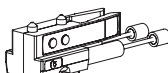
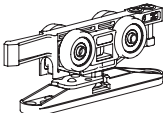
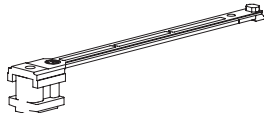



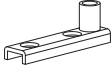

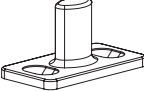

6 ÷ 15 mm

| N° | Barcode | Image | kg | Category | N° | Barcode | Image | kg | Category | |
|----|--------------------------------------|-------|----|------------|----|--------------------------------------|----------------------|----|------------------------|--------------------------|
| 1 | 2660 8 00 0.02660 8 01 0.02660 | | - | STANDARD | 1 | 3480 8 00 0.03480 8 01 0.03480 | | - | STANDARD NEW | |
| | 2670 8 00 0.02670 8 01 0.02670 | | - | OPTIONAL + | | 201 8 00 0.00201 8 01 0.00201 | | - | STANDARD | |
| | 1280 8 00 0.01280 8 01 0.01280 | | - | STANDARD | | 234 8 00 0.00234 8 01 0.00234 | | - | OPTIONAL + | |
| | 1080 8 00 0.01080 8 01 0.01080 | | - | OPTIONAL + | | 1710 8 00 0.01710 8 01 0.01710 | | - | OPTIONAL + | |
| | 1359 8 00 0.01359 8 01 0.01359 | | - | OPTIONAL + | | 1720 8 00 0.01720 8 01 0.01720 | | - | OPTIONAL + | |
| | 1559 8 00 0.01559 8 01 0.01559 | | - | OPTIONAL + | | 2 | 3490 8 02 0.03490 | | - | OPTIONAL + NEW |
| | 1700 8 00 0.01700 8 01 0.01700 | | - | OPTIONAL + | | | 3491 | | - | OPTIONAL + NEW |
| | 1160 8 00 0.01160 8 01 0.01160 | | - | STANDARD | | | 2665/T | | 30 | |
| | 160 8 00 0.00160 8 01 0.00160 | | - | OPTIONAL + | | 3 | 98/T | | 80 | |
| | 1660 8 00 0.01660 8 01 0.01660 | | - | OPTIONAL + | | | 1683/T | | 80 | |

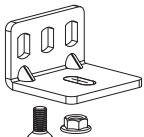
Step

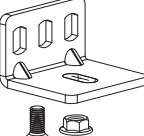
Automatic frontal bracket system
Scorrevoli con staffa automatica frontale

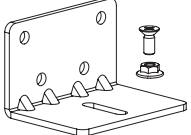
| N° | | | kg | | N° | | | kg | |
|----|---------|---|--------|--------------|----------|---|---|--------------|--------------|
| 3 | 1167/T |  | 160 | | 5 | 3508 |  | 180÷250 | FLUID NEW |
| | 209/T |  | 240 | | | 3372/050 |  | 50 | FLUID NEW |
| | 2664/T |  | 30 | | | 3372/080 |  | 80 | FLUID NEW |
| 4 | 2657 |  | 30 | | 3372/120 |  | 120 | FLUID NEW | |
| | 84 |  | 80 | | 3355/050 |  | 50 | FLUID NEW | |
| | 1627/10 |  | 80 | | 3355/080 |  | 80 | FLUID NEW | |
| | 1163 |  | 160 | | 3355/120 |  | 120 | FLUID NEW | |
| | 1165 |  | 240 | | 3485/180 |  | 180 | FLUID NEW | |
| | 2661 |  | 30 | | 3485/250 |  | 250 | FLUID NEW | |
| | 3378 |  | 50÷120 | FLUID NEW | 3354 |  | 50÷120 | FLUID NEW | |

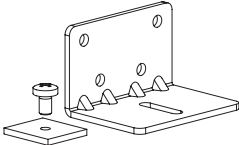
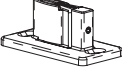
| N° | Barcode | | kg | | N° | Barcode | | kg | |
|------|---|---|------------|------------|---|---------|--|---|------------|
| 7 | 3347 |  | — | | 124 | |  | 160÷240 | |
| 8 | 121 8 23 0.00121 |  | 30÷120 | OPTIONAL + | 9 | 2855 |  | 180÷250 | NEW |
| | 705 8 23 0.00705 |  | 50÷120 | OPTIONAL + | | 1029 |  | — | |
| | 707 8 00 0.00707 8 01 0.00707 |  | 50÷120 | OPTIONAL + | | 409 |  | — | |
| | 760/N 8 14 0.00760 |  | 160÷240 | | | 10 | 126 |  | 30 |
| 1032 |  | 30 | | 127/D/V |  | | 50÷120 | | |
| 45 |  | 50÷80 | | 163/DV |  | | 160÷250 | | |
| 93 |  | 120 | | 163/PV |  | | 160÷250 | | |
| 90 |  | 30÷120 | OPTIONAL + | | | | | | |

Step

Automatic frontal bracket system
Scorrevoli con staffa automatica frontale

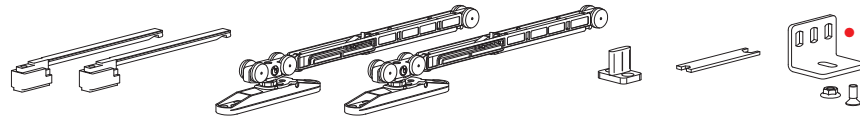

ART. 2660
(8000.02660)
(8010.02660)

30 kg

N.2 Soft damper stoppers
N.2 Fermi ammortizzati

Turned wheels
Ruote tornite

| | | | OLD CODE | NEW CODE | | TRACK-BINARIO | |
|----------------|---|------|----------------|----------------|----------------|---------------|----|
| KIT | • | N° 3 | 2664/2664/G/C | K.030.6.2.C | Min. 600 mm | — | 4x |
| | | — | 2664/2664/G/S | K.030.6.2.S | Min. 600 mm | — | 4x |
| BLISTER | • | N° 4 | 2664/2664/150C | B.030.6.2.C150 | 700 ÷ 850 mm | 1500 mm | 4x |
| | | N° 5 | 2664/2664/165C | B.030.6.2.C165 | 860 ÷ 950 mm | 1650 mm | 4x |
| | | N° 5 | 2664/2664/200C | B.030.6.2.C200 | 960 ÷ 1100 mm | 2000 mm | 4x |
| | | N° 6 | 2664/2664/250C | B.030.6.2.C250 | 1110 ÷ 1350 mm | 2500 mm | 4x |
| | | N° 7 | 2664/2664/300C | B.030.6.2.C300 | 1360 ÷ 1600 mm | 3000 mm | 4x |
| | | — | 2664/2664/150S | B.030.6.2.S150 | 700 ÷ 850 mm | 1500 mm | 4x |
| | | — | 2664/2664/165S | B.030.6.2.S165 | 860 ÷ 950 mm | 1650 mm | 4x |
| | | — | 2664/2664/200S | B.030.6.2.S200 | 960 ÷ 1100 mm | 2000 mm | 4x |
| | | — | 2664/2664/250S | B.030.6.2.S250 | 1110 ÷ 1350 mm | 2500 mm | 4x |
| | | — | 2664/2664/300S | B.030.6.2.S300 | 1360 ÷ 1600 mm | 3000 mm | 4x |

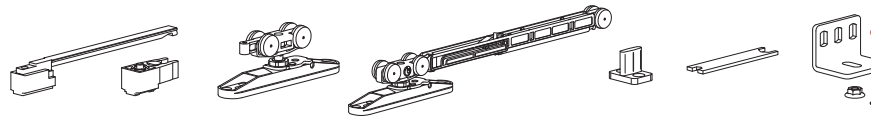

ART. 2660
(8000.02660)
(8010.02660)

30 kg

N.1 Soft damper stopper
N.1 Fermo ammortizzato

N.1 Standard stopper
N.1 Fermo standard

Turned wheels
Ruote tornite

| | | | OLD CODE | NEW CODE | | TRACK-BINARIO | |
|----------------|---|------|----------------|----------------|----------------|---------------|----|
| KIT | • | N° 3 | 2664/2665/G/C | K.030.5.2.C | Min. 600 mm | — | 4x |
| | | — | 2664/2665/G/S | K.030.5.2.S | Min. 600 mm | — | 4x |
| BLISTER | • | N° 4 | 2664/2665/150C | B.030.5.2.C150 | 700 ÷ 850 mm | 1500 mm | 4x |
| | | N° 5 | 2664/2665/165C | B.030.5.2.C165 | 860 ÷ 950 mm | 1650 mm | 4x |
| | | N° 5 | 2664/2665/200C | B.030.5.2.C200 | 960 ÷ 1100 mm | 2000 mm | 4x |
| | | N° 6 | 2664/2665/250C | B.030.5.2.C250 | 1110 ÷ 1350 mm | 2500 mm | 4x |
| | | N° 7 | 2664/2665/300C | B.030.5.2.C300 | 1360 ÷ 1600 mm | 3000 mm | 4x |
| | | — | 2664/2665/150S | B.030.5.2.S150 | 700 ÷ 850 mm | 1500 mm | 4x |
| | | — | 2664/2665/165S | B.030.5.2.S165 | 860 ÷ 950 mm | 1650 mm | 4x |
| | | — | 2664/2665/200S | B.030.5.2.S200 | 960 ÷ 1100 mm | 2000 mm | 4x |
| | | — | 2664/2665/250S | B.030.5.2.S250 | 1110 ÷ 1350 mm | 2500 mm | 4x |
| | | — | 2664/2665/300S | B.030.5.2.S300 | 1360 ÷ 1600 mm | 3000 mm | 4x |

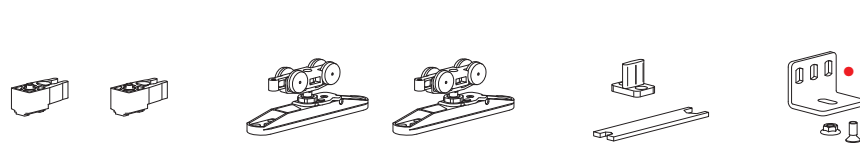

ART. 2660
(8000.02660)
(8010.02660)

30 kg

N.2 Standard stoppers
N.2 Fermi standard

Turned wheels
Ruote tornite

| | | | OLD CODE | NEW CODE | | TRACK-BINARIO | |
|----------------|---|------|----------------|----------------|----------------|---------------|----|
| KIT | • | N° 3 | 2665/2665/G/C | K.030.0.2.C | Min. 600 mm | — | 5x |
| | | — | 2665/2665/G/S | K.030.0.2.S | Min. 600 mm | — | 5x |
| BLISTER | • | N° 4 | 2665/2665/150C | B.030.0.2.C150 | 700 ÷ 850 mm | 1500 mm | 4x |
| | | N° 5 | 2665/2665/165C | B.030.0.2.C165 | 860 ÷ 950 mm | 1650 mm | 4x |
| | | N° 5 | 2665/2665/200C | B.030.0.2.C200 | 960 ÷ 1100 mm | 2000 mm | 4x |
| | | N° 6 | 2665/2665/250C | B.030.0.2.C250 | 1110 ÷ 1350 mm | 2500 mm | 4x |
| | | N° 7 | 2665/2665/300C | B.030.0.2.C300 | 1360 ÷ 1600 mm | 3000 mm | 4x |
| | | — | 2665/2665/150S | B.030.0.2.S150 | 700 ÷ 850 mm | 1500 mm | 4x |
| | | — | 2665/2665/165S | B.030.0.2.S165 | 860 ÷ 950 mm | 1650 mm | 4x |
| | | — | 2665/2665/200S | B.030.0.2.S200 | 960 ÷ 1100 mm | 2000 mm | 4x |
| | | — | 2665/2665/250S | B.030.0.2.S250 | 1110 ÷ 1350 mm | 2500 mm | 4x |
| | | — | 2665/2665/300S | B.030.0.2.S300 | 1360 ÷ 1600 mm | 3000 mm | 4x |

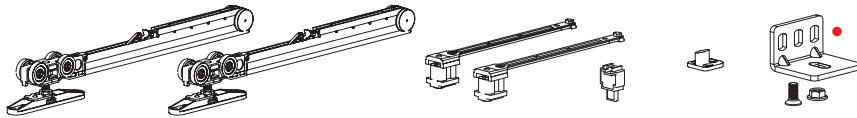

| | | OLD CODE | NEW CODE | | TRACK-BINARIO | |
|----------------|---|----------|----------|-----------------------|-------------------|---------|
| KIT | • | N° 4 | — | K.050.2.2.C | Min. 740 mm | — |
| | | — | — | K.050.2.2.S | Min. 740 mm | — |
| BLISTER | • | N° 4 | — | B.050.2.2.C150 | 740 ÷ 850 mm | 1500 mm |
| | | N° 5 | — | B.050.2.2.C165 | 860 ÷ 950 mm | 1650 mm |
| | | N° 5 | — | B.050.2.2.C200 | 960 ÷ 1100 mm | 2000 mm |
| | | N° 6 | — | B.050.2.2.C250 | 1110 ÷ 1350 mm | 2500 mm |
| | | N° 7 | — | B.050.2.2.C300 | 1360 ÷ 1600 mm | 3000 mm |
| | | — | — | B.050.2.2.S150 | 700 ÷ 850 mm | 1500 mm |
| | | — | — | B.050.2.2.S165 | 860 ÷ 950 mm | 1650 mm |
| | | — | — | B.050.2.2.S200 | 960 ÷ 1100 mm | 2000 mm |
| | | — | — | B.050.2.2.S250 | 1110 ÷ 1350 mm | 2500 mm |
| | | — | — | B.050.2.2.S300 | 1360 ÷ 1600 mm | 3000 mm |

50 kg

N.2 Fluid dampers
 N.2 Fermi ammortizzati
FLUID Fluid

Ball bearings
Cuscinetti a sfera

FLUID

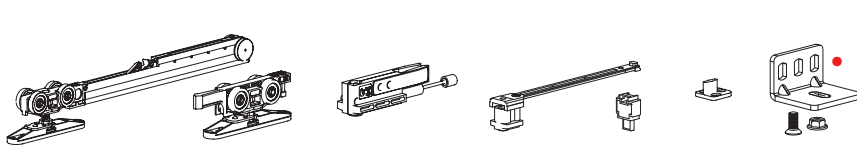

| | | OLD CODE | NEW CODE | | TRACK-BINARIO | |
|----------------|---|----------|----------|-----------------------|-------------------|---------|
| KIT | • | N° 4 | — | K.050.1.2.C | Min. 600 mm | — |
| | | — | — | K.050.1.2.S | Min. 600 mm | — |
| BLISTER | • | N° 4 | — | B.050.1.2.C150 | 700 ÷ 850 mm | 1500 mm |
| | | N° 5 | — | B.050.1.2.C165 | 860 ÷ 950 mm | 1650 mm |
| | | N° 5 | — | B.050.1.2.C200 | 960 ÷ 1100 mm | 2000 mm |
| | | N° 6 | — | B.050.1.2.C250 | 1110 ÷ 1350 mm | 2500 mm |
| | | N° 7 | — | B.050.1.2.C300 | 1360 ÷ 1600 mm | 3000 mm |
| | | — | — | B.050.1.2.S150 | 700 ÷ 850 mm | 1500 mm |
| | | — | — | B.050.1.2.S165 | 860 ÷ 950 mm | 1650 mm |
| | | — | — | B.050.1.2.S200 | 960 ÷ 1100 mm | 2000 mm |
| | | — | — | B.050.1.2.S250 | 1110 ÷ 1350 mm | 2500 mm |
| | | — | — | B.050.1.2.S300 | 1360 ÷ 1600 mm | 3000 mm |

50 kg

N.1 Fluid damper
 N.1 Fermo ammortizzato
FLUID Fluid

N.1 Shock absorber
 N.1 Fermo a pinza ammortizzato

Ball bearings
Cuscinetti a sfera

FLUID

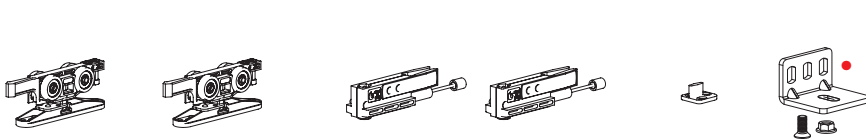

| | | OLD CODE | NEW CODE | | TRACK-BINARIO | |
|----------------|---|----------|----------|-----------------------|-------------------|---------|
| KIT | • | N° 4 | — | K.050.3.2.C | Min. 600 mm | — |
| | | — | — | K.050.3.2.S | Min. 600 mm | — |
| BLISTER | • | N° 4 | — | B.050.3.2.C150 | 700 ÷ 850 mm | 1500 mm |
| | | N° 5 | — | B.050.3.2.C165 | 860 ÷ 950 mm | 1650 mm |
| | | N° 5 | — | B.050.3.2.C200 | 960 ÷ 1100 mm | 2000 mm |
| | | N° 6 | — | B.050.3.2.C250 | 1110 ÷ 1350 mm | 2500 mm |
| | | N° 7 | — | B.050.3.2.C300 | 1360 ÷ 1600 mm | 3000 mm |
| | | — | — | B.050.3.2.S150 | 700 ÷ 850 mm | 1500 mm |
| | | — | — | B.050.3.2.S165 | 860 ÷ 950 mm | 1650 mm |
| | | — | — | B.050.3.2.S200 | 960 ÷ 1100 mm | 2000 mm |
| | | — | — | B.050.3.2.S250 | 1110 ÷ 1350 mm | 2500 mm |
| | | — | — | B.050.3.2.S300 | 1360 ÷ 1600 mm | 3000 mm |

50 kg

N.2 Shock absorber
 N.2 Fermi a pinza ammortizzati

Ball bearings
Cuscinetti a sfera

FLUID

Step

Automatic frontal bracket system
Scorrevoli con staffa automatica frontale

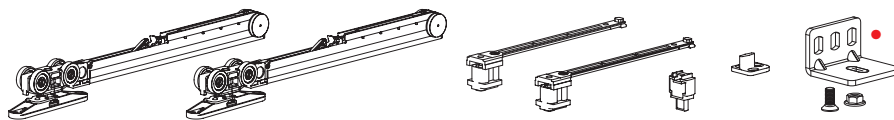

ART. 1280
(8000.01280)
(8010.01280)

FLUID



80 kg



N.2 Fluid dampers
N.2 Fermi ammortizzati
Fluid



Ball bearings
Cuscinetti a sfera

| | | | OLD CODE | NEW CODE | | TRACK-BINARIO | |
|----------------|---|------|----------|-----------------------|----------------|-------------------|----|
| KIT | ● | N° 5 | — | K.080.2.2.C | Min. 740 mm | — | 4x |
| | | | — | K.080.2.2.S | Min. 740 mm | — | 4x |
| BLISTER | ● | N° 4 | — | B.080.2.2.C150 | 740 ÷ 850 mm | 1500 mm | 4x |
| | | N° 5 | — | B.080.2.2.C165 | 860 ÷ 950 mm | 1650 mm | 4x |
| | | N° 5 | — | B.080.2.2.C200 | 960 ÷ 1100 mm | 2000 mm | 4x |
| | | N° 6 | — | B.080.2.2.C250 | 1110 ÷ 1350 mm | 2500 mm | 4x |
| | | N° 7 | — | B.080.2.2.C300 | 1360 ÷ 1600 mm | 3000 mm | 4x |
| | | — | — | B.080.2.2.S150 | 700 ÷ 850 mm | 1500 mm | 4x |
| | | — | — | B.080.2.2.S165 | 860 ÷ 950 mm | 1650 mm | 4x |
| | | — | — | B.080.2.2.S200 | 960 ÷ 1100 mm | 2000 mm | 4x |
| | | — | — | B.080.2.2.S250 | 1110 ÷ 1350 mm | 2500 mm | 4x |
| | | — | — | B.080.2.2.S300 | 1360 ÷ 1600 mm | 3000 mm | 4x |

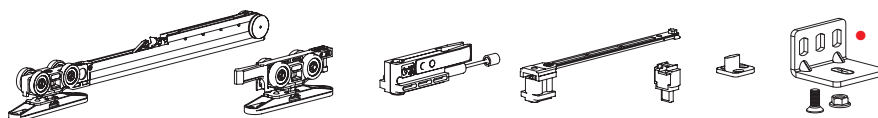

ART. 1280
(8000.01280)
(8010.01280)

FLUID



80 kg



N.1 Fluid damper
N.1 Fermo ammortizzato
Fluid



N.1 Shock absorber
N.1 Fermo a pinza
ammortizzato



Ball bearings
Cuscinetti a sfera

| | | | OLD CODE | NEW CODE | | TRACK-BINARIO | |
|----------------|---|------|----------|-----------------------|----------------|-------------------|----|
| KIT | ● | N° 5 | — | K.080.1.2.C | Min. 600 mm | — | 4x |
| | | | — | K.080.1.2.S | Min. 600 mm | — | 4x |
| BLISTER | ● | N° 4 | — | B.080.1.2.C150 | 700 ÷ 850 mm | 1500 mm | 4x |
| | | N° 5 | — | B.080.1.2.C165 | 860 ÷ 950 mm | 1650 mm | 4x |
| | | N° 5 | — | B.080.1.2.C200 | 960 ÷ 1100 mm | 2000 mm | 4x |
| | | N° 6 | — | B.080.1.2.C250 | 1110 ÷ 1350 mm | 2500 mm | 4x |
| | | N° 7 | — | B.080.1.2.C300 | 1360 ÷ 1600 mm | 3000 mm | 4x |
| | | — | — | B.080.1.2.S150 | 700 ÷ 850 mm | 1500 mm | 4x |
| | | — | — | B.080.1.2.S165 | 860 ÷ 950 mm | 1650 mm | 4x |
| | | — | — | B.080.1.2.S200 | 960 ÷ 1100 mm | 2000 mm | 4x |
| | | — | — | B.080.1.2.S250 | 1110 ÷ 1350 mm | 2500 mm | 4x |
| | | — | — | B.080.1.2.S300 | 1360 ÷ 1600 mm | 3000 mm | 4x |

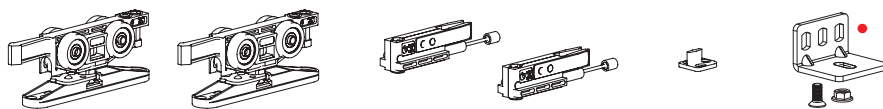

ART. 1280
(8000.01280)
(8010.01280)

FLUID



80 kg



N.2 Shock absorber
N.2 Fermi a pinza
ammortizzati



Ball bearings
Cuscinetti a sfera

| | | | OLD CODE | NEW CODE | | TRACK-BINARIO | |
|----------------|---|------|----------|-----------------------|----------------|-------------------|----|
| KIT | ● | N° 5 | — | K.080.3.2.C | Min. 600 mm | — | 5x |
| | | | — | K.080.3.2.S | Min. 600 mm | — | 5x |
| BLISTER | ● | N° 4 | — | B.080.3.2.C150 | 700 ÷ 850 mm | 1500 mm | 4x |
| | | N° 5 | — | B.080.3.2.C165 | 860 ÷ 950 mm | 1650 mm | 4x |
| | | N° 5 | — | B.080.3.2.C200 | 960 ÷ 1100 mm | 2000 mm | 4x |
| | | N° 6 | — | B.080.3.2.C250 | 1110 ÷ 1350 mm | 2500 mm | 4x |
| | | N° 7 | — | B.080.3.2.C300 | 1360 ÷ 1600 mm | 3000 mm | 4x |
| | | — | — | B.080.3.2.S150 | 700 ÷ 850 mm | 1500 mm | 4x |
| | | — | — | B.080.3.2.S165 | 860 ÷ 950 mm | 1650 mm | 4x |
| | | — | — | B.080.3.2.S200 | 960 ÷ 1100 mm | 2000 mm | 4x |
| | | — | — | B.080.3.2.S250 | 1110 ÷ 1350 mm | 2500 mm | 4x |
| | | — | — | B.080.3.2.S300 | 1360 ÷ 1600 mm | 3000 mm | 4x |

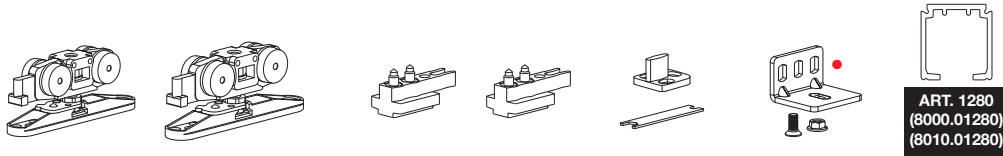

| KIT | ● | N° 5 | OLD CODE | NEW CODE | Min. 600 mm | TRACK-BINARIO | MIN |
|---------|---|------|-----------------|----------------|----------------|---------------|-----|
| | | | 80/T/G/AF/CON | K.080.0.2.C | | — | |
| | | — | 80/T/G/AF/SEN | K.080.0.2.S | Min. 600 mm | — | 5x |
| BLISTER | ● | N° 4 | 80/T/P/AF150CON | B.080.0.2.C150 | 700 ÷ 850 mm | 1500 mm | 4x |
| | | N° 5 | 80/T/P/AF165CON | B.080.0.2.C165 | 860 ÷ 950 mm | 1650 mm | 4x |
| | | N° 5 | 80/T/P/AF200CON | B.080.0.2.C200 | 960 ÷ 1100 mm | 2000 mm | 4x |
| | | N° 6 | 80/T/P/AF250CON | B.080.0.2.C250 | 1110 ÷ 1350 mm | 2500 mm | 4x |
| | | N° 7 | 80/T/P/AF300CON | B.080.0.2.C300 | 1360 ÷ 1600 mm | 3000 mm | 4x |
| | | — | 80/T/P/AF150SEN | B.080.0.2.S150 | 700 ÷ 850 mm | 1500 mm | 4x |
| | | — | 80/T/P/AF165SEN | B.080.0.2.S165 | 860 ÷ 950 mm | 1650 mm | 4x |
| | | — | 80/T/P/AF200SEN | B.080.0.2.S200 | 960 ÷ 1100 mm | 2000 mm | 4x |
| | | — | 80/T/P/AF250SEN | B.080.0.2.S250 | 1110 ÷ 1350 mm | 2500 mm | 4x |
| | | — | 80/T/P/AF300SEN | B.080.0.2.S300 | 1360 ÷ 1600 mm | 3000 mm | 4x |



80 kg



N.2 Standard stopper
N.2 Fermi standard



Turned wheels
Ruote tornite

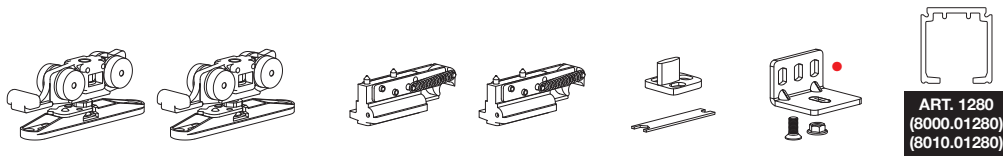

| KIT | ● | N° 5 | OLD CODE | NEW CODE | Min. 700 mm | TRACK-BINARIO | MIN |
|---------|---|------|----------------|----------------|----------------|---------------|-----|
| | | | 80/TG/AF/C/FAN | K.080.4.2.C | | — | |
| | | — | 80/TG/AF/S/FAN | K.080.4.2.S | Min. 700 mm | — | 5x |
| BLISTER | ● | N° 4 | 80T/PAF150CFAN | B.080.4.2.C150 | 700 ÷ 850 mm | 1500 mm | 4x |
| | | N° 5 | 80T/PAF165CFAN | B.080.4.2.C165 | 860 ÷ 950 mm | 1650 mm | 4x |
| | | N° 5 | 80T/PAF200CFAN | B.080.4.2.C200 | 960 ÷ 1100 mm | 2000 mm | 4x |
| | | N° 6 | 80T/PAF250CFAN | B.080.4.2.C250 | 1110 ÷ 1350 mm | 2500 mm | 4x |
| | | N° 7 | 80T/PAF300CFAN | B.080.4.2.C300 | 1360 ÷ 1600 mm | 3000 mm | 4x |
| | | — | 80T/PAF150SFAN | B.080.4.2.S150 | 700 ÷ 850 mm | 1500 mm | 4x |
| | | — | 80T/PAF165SFAN | B.080.4.2.S165 | 860 ÷ 950 mm | 1650 mm | 4x |
| | | — | 80T/PAF200CFAN | B.080.4.2.S200 | 960 ÷ 1100 mm | 2000 mm | 4x |
| | | — | 80T/PAF250SFAN | B.080.4.2.S250 | 1110 ÷ 1350 mm | 2500 mm | 4x |
| | | — | 80T/PAF300SFAN | B.080.4.2.S300 | 1360 ÷ 1600 mm | 3000 mm | 4x |



80 kg



N.2 Hydraulic stopper
N.2 Fermi idraulici



Suitable for naval sector
Adatto per settore navale



Turned wheels
Ruote tornite

Step

Automatic frontal bracket system
Scorrevoli con staffa automatica frontale

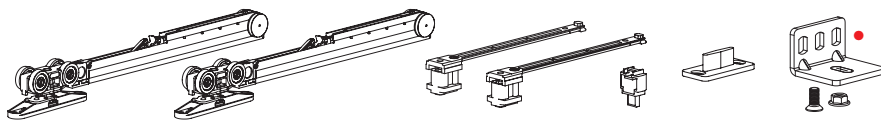

ART. 1280
(8000.01280)
(8010.01280)

FLUID



120 kg



N.2 Fluid dampers
N.2 Fermi ammortizzati
Fluid



Ball bearings
Cuscinetti a sfera

| | | | OLD CODE | NEW CODE | | TRACK-BINARIO | |
|----------------|-----------------------|----------------|----------|-----------------------|----------------|-------------------|----|
| KIT | ● | N° 6 | — | K.120.2.2.C | Min. 740 mm | — | 4x |
| | | | — | K.120.2.2.S | Min. 740 mm | — | 4x |
| BLISTER | ● | N° 4 | — | B.120.2.2.C150 | 740 ÷ 850 mm | 1500 mm | 4x |
| | | | — | B.120.2.2.C165 | 860 ÷ 950 mm | 1650 mm | 4x |
| | | | — | B.120.2.2.C200 | 960 ÷ 1100 mm | 2000 mm | 4x |
| | | | — | B.120.2.2.C250 | 1110 ÷ 1350 mm | 2500 mm | 4x |
| | | | — | B.120.2.2.C300 | 1360 ÷ 1600 mm | 3000 mm | 4x |
| | | | — | B.120.2.2.S150 | 700 ÷ 850 mm | 1500 mm | 4x |
| | | | — | B.120.2.2.S165 | 860 ÷ 950 mm | 1650 mm | 4x |
| | | | — | B.120.2.2.S200 | 960 ÷ 1100 mm | 2000 mm | 4x |
| — | B.120.2.2.S250 | 1110 ÷ 1350 mm | 2500 mm | 4x | | | |
| — | B.120.2.2.S300 | 1360 ÷ 1600 mm | 3000 mm | 4x | | | |

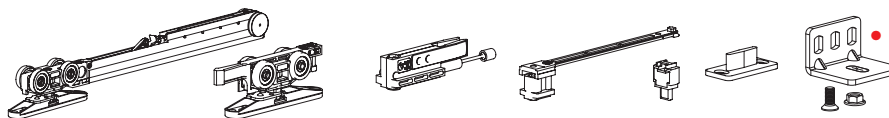

ART. 1280
(8000.01280)
(8010.01280)

FLUID



120 kg



N.1 Fluid damper
N.1 Fermo ammortizzato
Fluid



N.1 Shock absorber
N.1 Fermo a pinza
ammortizzato



Ball bearings
Cuscinetti a sfera

| | | | OLD CODE | NEW CODE | | TRACK-BINARIO | |
|----------------|-----------------------|----------------|----------|-----------------------|----------------|-------------------|----|
| KIT | ● | N° 6 | — | K.120.1.2.C | Min. 600 mm | — | 4x |
| | | | — | K.120.1.2.S | Min. 600 mm | — | 4x |
| BLISTER | ● | N° 4 | — | B.120.1.2.C150 | 700 ÷ 850 mm | 1500 mm | 4x |
| | | | — | B.120.1.2.C165 | 860 ÷ 950 mm | 1650 mm | 4x |
| | | | — | B.120.1.2.C200 | 960 ÷ 1100 mm | 2000 mm | 4x |
| | | | — | B.120.1.2.C250 | 1110 ÷ 1350 mm | 2500 mm | 4x |
| | | | — | B.120.1.2.C300 | 1360 ÷ 1600 mm | 3000 mm | 4x |
| | | | — | B.120.1.2.S150 | 700 ÷ 850 mm | 1500 mm | 4x |
| | | | — | B.120.1.2.S165 | 860 ÷ 950 mm | 1650 mm | 4x |
| | | | — | B.120.1.2.S200 | 960 ÷ 1100 mm | 2000 mm | 4x |
| — | B.120.1.2.S250 | 1110 ÷ 1350 mm | 2500 mm | 4x | | | |
| — | B.120.1.2.S300 | 1360 ÷ 1600 mm | 3000 mm | 4x | | | |

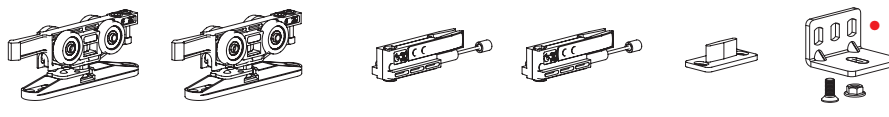

ART. 1280
(8000.01280)
(8010.01280)

FLUID



120 kg



N.2 Shock absorber
N.2 Fermi a pinza
ammortizzati



Ball bearings
Cuscinetti a sfera

| | | | OLD CODE | NEW CODE | | TRACK-BINARIO | |
|----------------|-----------------------|----------------|----------|-----------------------|----------------|-------------------|----|
| KIT | ● | N° 6 | — | K.120.3.2.C | Min. 600 mm | — | 5x |
| | | | — | K.120.3.2.S | Min. 600 mm | — | 5x |
| BLISTER | ● | N° 4 | — | B.120.3.2.C150 | 700 ÷ 850 mm | 1500 mm | 4x |
| | | | — | B.120.3.2.C165 | 860 ÷ 950 mm | 1650 mm | 4x |
| | | | — | B.120.3.2.C200 | 960 ÷ 1100 mm | 2000 mm | 4x |
| | | | — | B.120.3.2.C250 | 1110 ÷ 1350 mm | 2500 mm | 4x |
| | | | — | B.120.3.2.C300 | 1360 ÷ 1600 mm | 3000 mm | 4x |
| | | | — | B.120.3.2.S150 | 700 ÷ 850 mm | 1500 mm | 4x |
| | | | — | B.120.3.2.S165 | 860 ÷ 950 mm | 1650 mm | 4x |
| | | | — | B.120.3.2.S200 | 960 ÷ 1100 mm | 2000 mm | 4x |
| — | B.120.3.2.S250 | 1110 ÷ 1350 mm | 2500 mm | 4x | | | |
| — | B.120.3.2.S300 | 1360 ÷ 1600 mm | 3000 mm | 4x | | | |

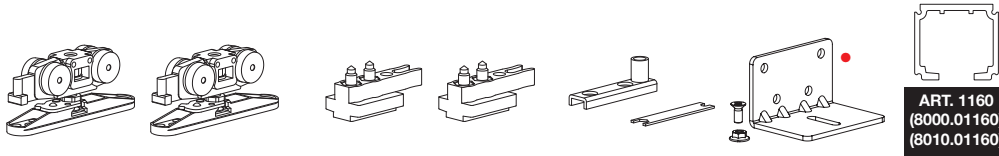

| | | | OLD CODE | NEW CODE | | TRACK-BINARIO | |
|----------------|---|------|------------------|----------------|----------------|---------------|----|
| KIT | ● | N° 6 | 160/T/G/AF/CON | K.160.0.2.C | Min. 700 mm | — | 5x |
| | | — | 160/T/G/AF/SEN | K.160.0.2.S | Min. 700 mm | — | 5x |
| BLISTER | ● | N° 6 | 160/T/P/AF200CON | B.160.0.2.C200 | 960 ÷ 1100 mm | 2000 mm | 4x |
| | | N° 7 | 160/T/P/AF250CON | B.160.0.2.C250 | 1110 ÷ 1350 mm | 2500 mm | 4x |
| | | N° 8 | 160/T/P/AF300CON | B.160.0.2.C300 | 1360 ÷ 1600 mm | 3000 mm | 4x |
| | | — | 160/T/P/AF200SEN | B.160.0.2.S200 | 960 ÷ 1100 mm | 2000 mm | 4x |
| | | — | 160/T/P/AF250SEN | B.160.0.2.S250 | 1110 ÷ 1350 mm | 2500 mm | 4x |
| | | — | 160/T/P/AF300SEN | B.160.0.2.S300 | 1360 ÷ 1600 mm | 3000 mm | 4x |



160 kg



N.2 Standard stoppers
N.2 Fermi standard



Turned wheels
Ruote tornite

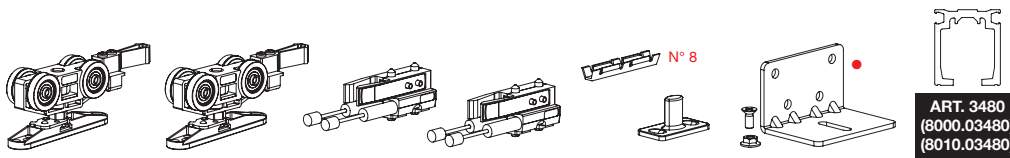

| | | | OLD CODE | NEW CODE | | TRACK-BINARIO | |
|----------------|---|------|----------|----------------|----------------|---------------|----|
| KIT | ● | N° 6 | — | K.180.3.2.C | Min. 700 mm | — | 5x |
| | | — | — | K.180.3.2.S | Min. 700 mm | — | 5x |
| BLISTER | ● | N° 6 | — | B.180.3.2.C200 | 960 ÷ 1100 mm | 2000 mm | 4x |
| | | N° 7 | — | B.180.3.2.C250 | 1110 ÷ 1350 mm | 2500 mm | 4x |
| | | N° 8 | — | B.180.3.2.C300 | 1360 ÷ 1600 mm | 3000 mm | 4x |
| | | — | — | B.180.3.2.S200 | 960 ÷ 1100 mm | 2000 mm | 4x |
| | | — | — | B.180.3.2.S250 | 1110 ÷ 1350 mm | 2500 mm | 4x |
| | | — | — | B.180.3.2.S300 | 1360 ÷ 1600 mm | 3000 mm | 4x |



180 kg



N.2 Shock absorber
N.2 Fermi a pinza
ammortizzati



Ball bearings
Cuscinetti a sfera

Step

Automatic frontal bracket system
Scorrevoli con staffa automatica frontale

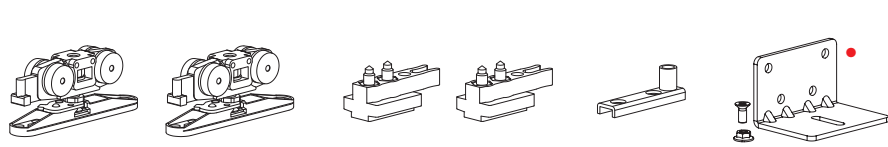





ART. 201
(8000.0201)
(8010.0201)

 **240 kg**

 N.2 Standard stoppers
N.2 Fermi standard

 Turned wheels
Ruote tornite

|  |  | OLD CODE | NEW CODE |  | TRACK-BINARIO  |  |
|---|---|------------------|-----------------------|---|--|---|
| KIT | ● N° 7 | 240/T/G/AF/CON | K.240.0.2.C | Min. 700 mm | — | 5x |
| | — | 240/T/G/AF/SEN | K.240.0.2.S | Min. 700 mm | — | 5x |
| BLISTER | ● N° 6 | 240/T/P/AF200CON | B.240.0.2.C200 | 960 ÷ 1100 mm | 2000 mm | 4x |
| | ● N° 7 | 240/T/P/AF250CON | B.240.0.2.C250 | 1110 ÷ 1350 mm | 2500 mm | 4x |
| | ● N° 8 | 240/T/P/AF300CON | B.240.0.2.C300 | 1360 ÷ 1600 mm | 3000 mm | 4x |
| | — | 240/T/P/AF200SEN | B.240.0.2.S200 | 960 ÷ 1100 mm | 2000 mm | 4x |
| | — | 240/T/P/AF250SEN | B.240.0.2.S250 | 1110 ÷ 1350 mm | 2500 mm | 4x |
| | — | 240/T/P/AF300SEN | B.240.0.2.S300 | 1360 ÷ 1600 mm | 3000 mm | 4x |

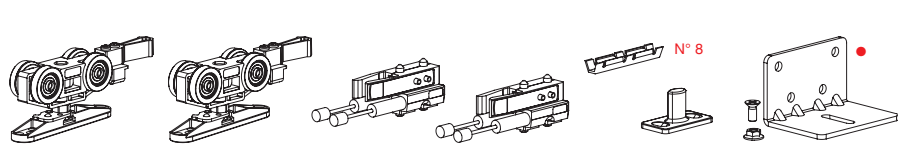





ART. 3480
(8000.03480)
(8010.03480)

 **250 kg**

 N.2 Shock absorber
N.2 Fermi a pinza
ammortizzati

 Ball bearings
Cuscinetti a sfera

|  |  | OLD CODE | NEW CODE |  | TRACK-BINARIO  |  |
|---|---|----------|-----------------------|---|--|---|
| KIT | ● N° 7 | — | K.250.3.2.C | Min. 700 mm | — | 5x |
| | — | — | K.250.3.2.S | Min. 700 mm | — | 5x |
| BLISTER | ● N° 6 | — | B.250.3.2.C200 | 960 ÷ 1100 mm | 2000 mm | 4x |
| | ● N° 7 | — | B.250.3.2.C250 | 1110 ÷ 1350 mm | 2500 mm | 4x |
| | ● N° 8 | — | B.250.3.2.C300 | 1360 ÷ 1600 mm | 3000 mm | 4x |
| | — | — | B.250.3.2.S200 | 960 ÷ 1100 mm | 2000 mm | 4x |
| | — | — | B.250.3.2.S250 | 1110 ÷ 1350 mm | 2500 mm | 4x |
| | — | — | B.250.3.2.S300 | 1360 ÷ 1600 mm | 3000 mm | 4x |

FLUID

N.2 Soft damper stoppers
N.2 Fermi ammortizzati



N.1 Soft damper stopper + N.1 Standard stopper
N.1 Fermo ammortizzato + N.1 Fermo standard



N.2 Standard stoppers
N.2 Fermi standard

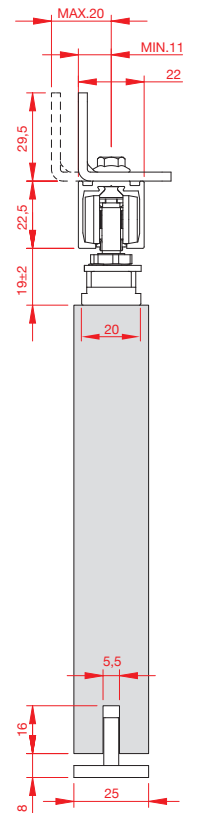
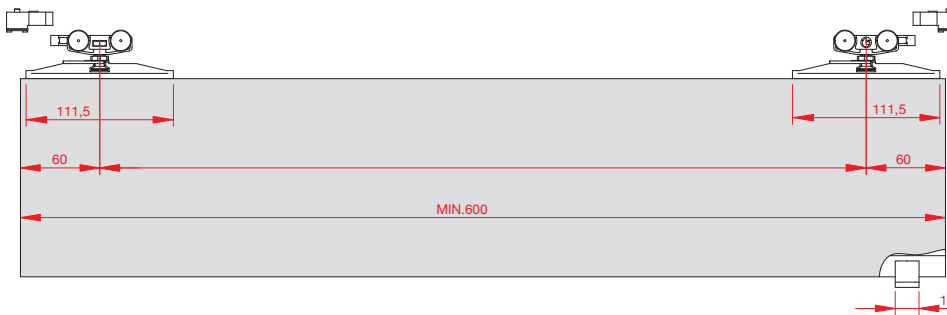

Step

Automatic frontal bracket system
Scorrevoli con staffa automatica frontale

N.2 Fluid dampers N.2 Fermi ammortizzati Fluid

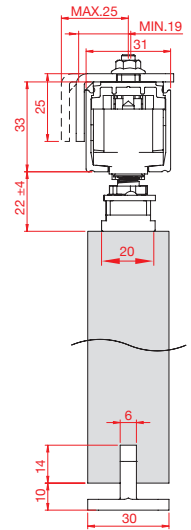
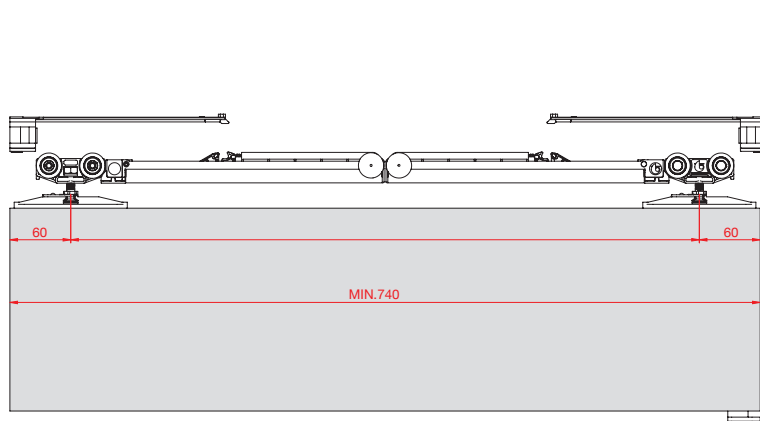

N.1 Fluid damper + N.1 Shock absorber N.1 Fermo ammortizzato Fluid + N.1 Fermo a pinza ammortizzato

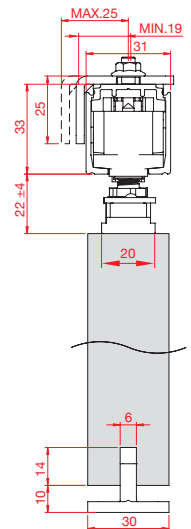
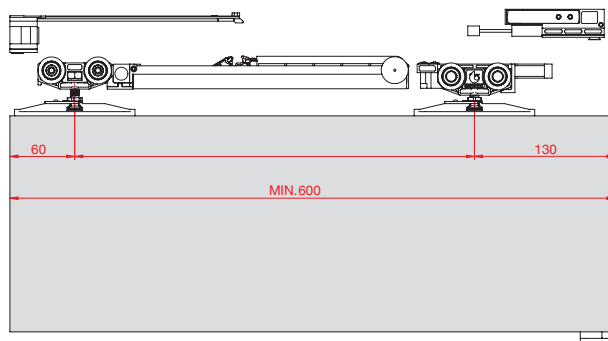

N.2 Shock absorber N.2 Fermi a pinza ammortizzati

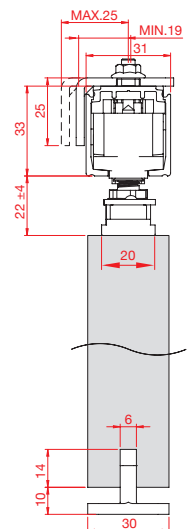
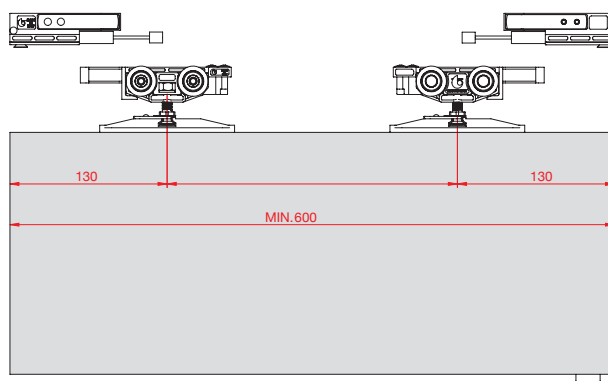

FLUID



50 kg
80 kg
120 kg

N.2 Standard stoppers
N.2 Fermi standard

80 kg

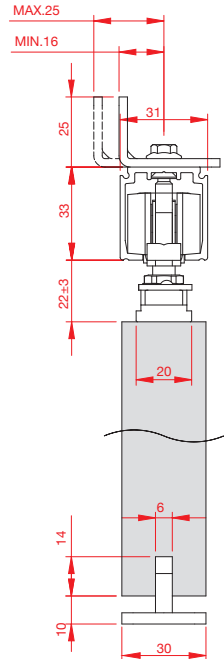
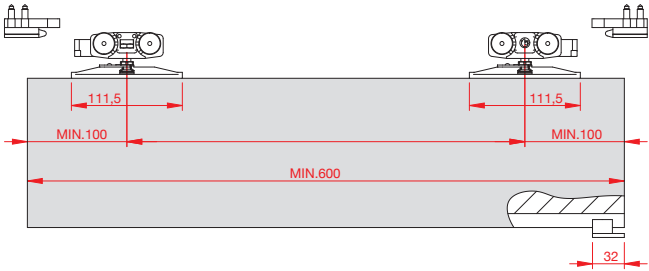

N.2 Hydraulic stopper
N.2 Fermi idraulici

80 kg

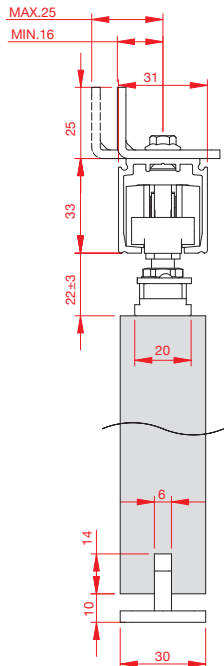
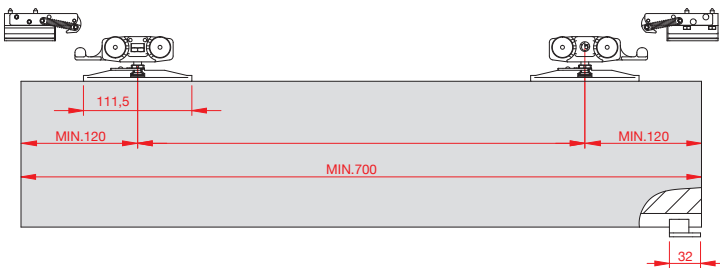

Step

Automatic frontal bracket system
Scorrevoli con staffa automatica frontale

N.2 Standard stoppers
N.2 Fermi standard



160 kg

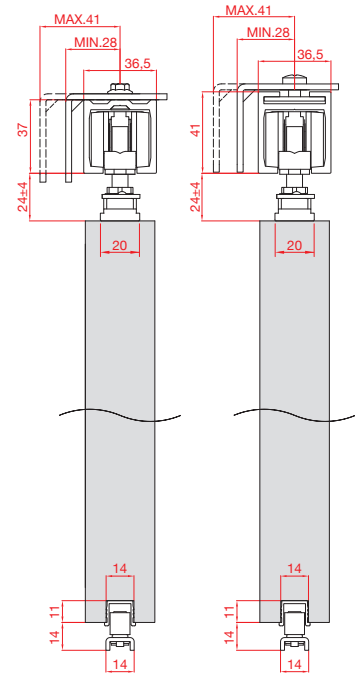
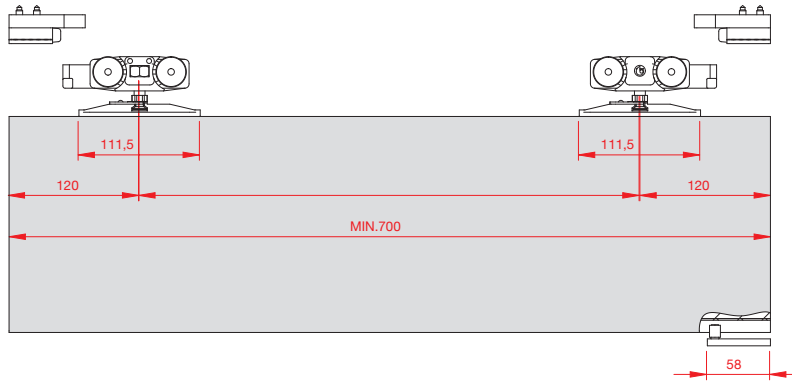

N.2 Shock absorber
N.2 Fermi a pinza ammortizzati

FLUID



180 kg

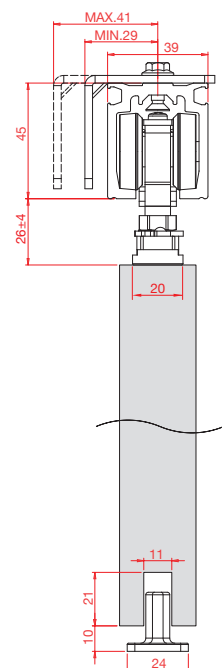
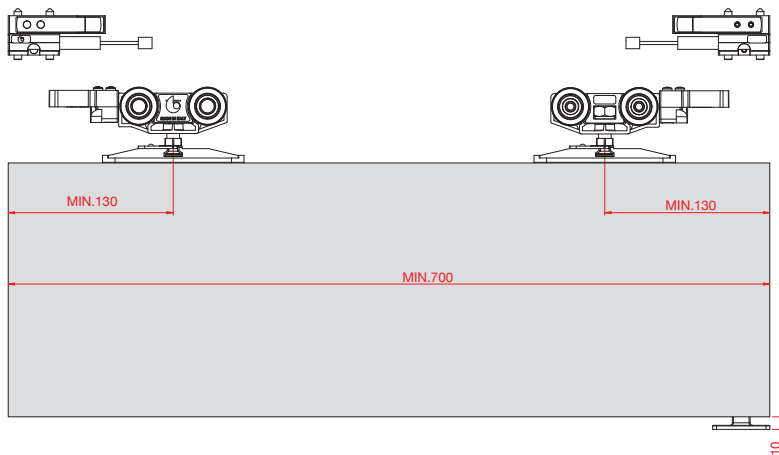

N.2 Standard stoppers
N.2 Fermi standard

240 kg

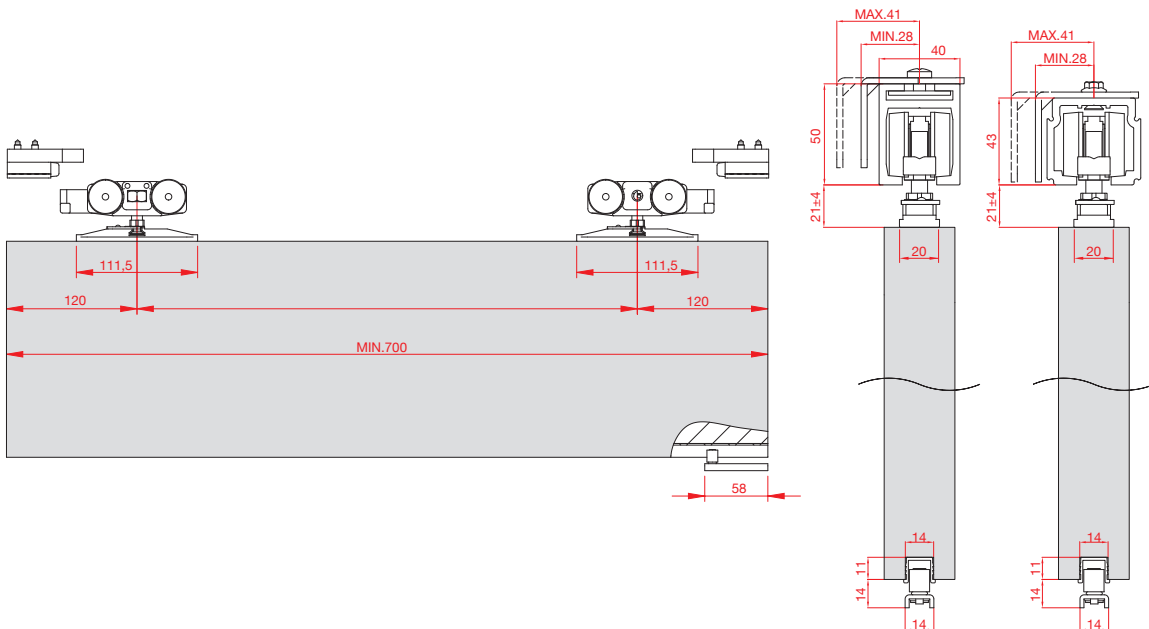

N.2 Shock absorber
N.2 Fermi a pinza ammortizzati

250 kg

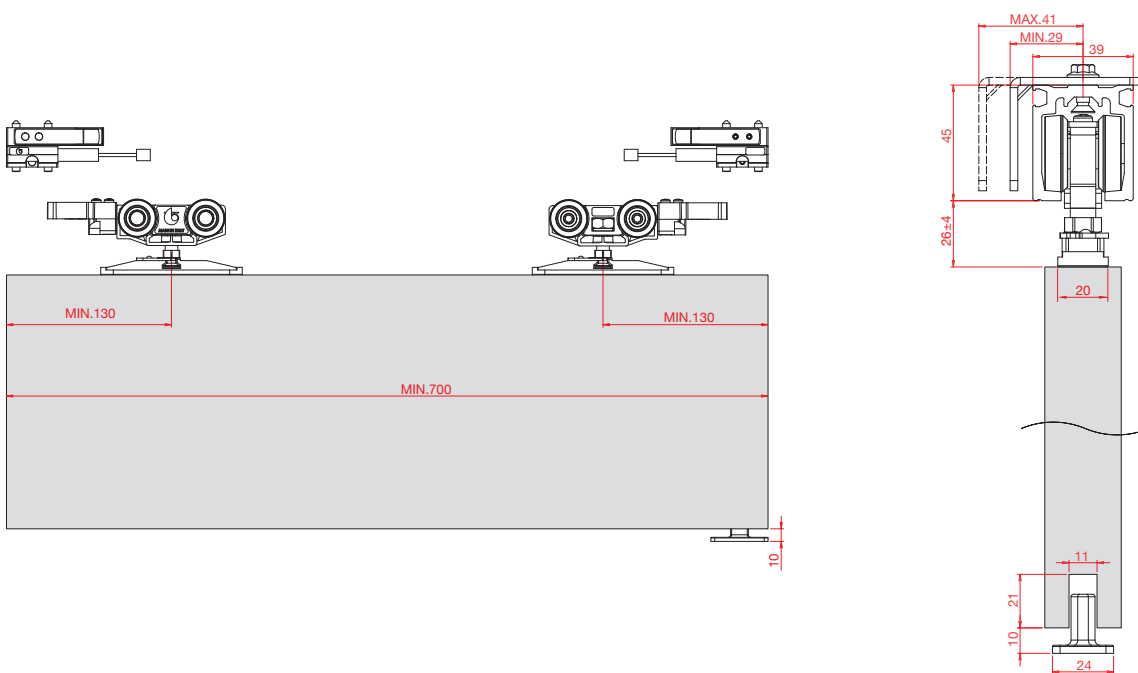

FLUID



Sync

Mechanisms for simultaneous opening wooden doors
Meccanismi per porte in legno ad apertura simultanea





Sync sliding system is a solution specifically designed to realize wooden doors with synchronized opening motion.

Extremely easy to install, Sync is compatible with all traditional bracket system on the catalogue: **Classic, Evolution, Eclettica, Step and Hide.**







Sync system integrates the innovative **Fluid** technology, which allows a revolutionary (groundbreaking) and extremely light sliding motion.

Sync è il sistema di meccanismi scorrevoli appositamente studiato per porte in legno con apertura simultanea.

Estremamente facile da montare, è compatibile con tutte le staffe presenti a catalogo: **Classic, Evolution, Eclettica, Step e Hide.**

Il sistema **Sync** integra l'innovativa tecnologia **Fluid**, che rende il movimento rivoluzionario ed estremamente leggero.



| Sync | | COMPLETE BOX KIT / KIT COMPLETO IN SCATOLA | |  |
|-------------|---|---|--|---|
| K | Complete kit for N°1 simultaneous opening door / Kit completo per N°1 porta con apertura simultanea | | | |
| | 0131 |  | SYNC Complete Kit Kit Completo SYNC | |
| | 0132 |  | SYNC Accessories Kit Kit Accessori SYNC | |
| | | 0 | N.2 Standard stoppers N.2 Fermi standard |  |
| | | 6 | N.2 Fluid dampers N.2 Fermi ammortizzati Fluid |  |
| | | 7 | N.2 Shock absorber N.2 Fermi a pinza ammortizzati |  |

EXAMPLE / ESEMPIO

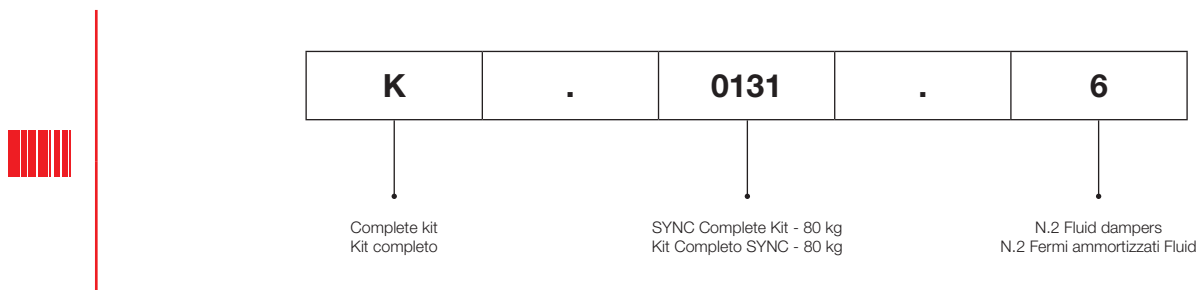

| Tracks / Binari | | ALUMINUM FINISHES CODES / CODICI FINITURE ALLUMINIO | |  |
|------------------------|---|---|-------------------------------------|---|
| CODE / CODICE | FINISH COLOR / COLORE FINITURA | | | |
| 8 00 0.0 |  | 00 G | Row - Mill Finish / Neutro - Grezzo | STANDARD |
| 8 01 0.0 |  | 01 A | Anodized Silver / Argento | |

| Tracks / Binari | | PLASTIC FINISHES CODES / CODICI FINITURE PLASTICA | |  |
|------------------------|---|---|---------------|---|
| CODE / CODICE | FINISH COLOR / COLORE FINITURA | | | |
| 8 23 0.0 |  | 23 GR | Gray / Grigio | STANDARD |

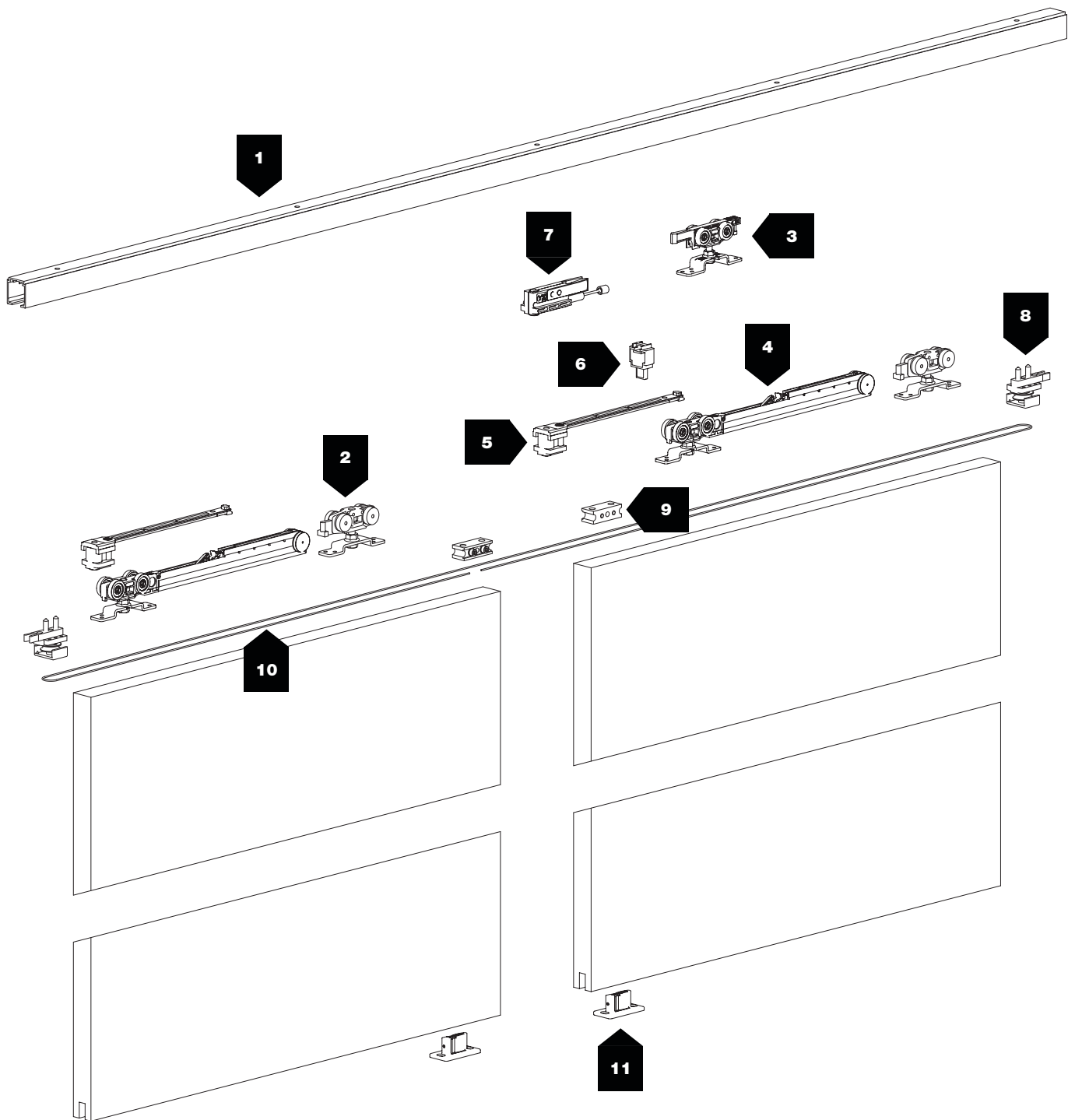









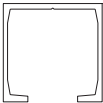

Min 30 mm

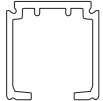
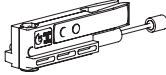

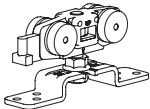
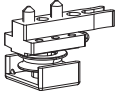
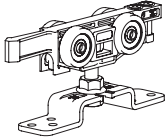
80 kg

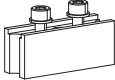
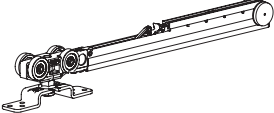

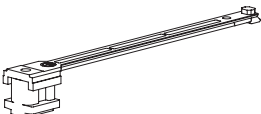
10 mm

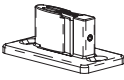
| N° | | | kg | | N° | | | kg | |
|----|--------------------------------------|---|----|---|----|----------|---|----|---|
| 1 | 1080 8 00 0.01080 8 01 0.01080 |  | — | | 6 | 3347 |  | — | |
| | 1280 8 00 0.01280 8 01 0.01280 |  | — | | 7 | 3355/080 |  | 80 |  NEW |
| 2 | 81/T |  | 80 | | 8 | 86 |  | 80 | |
| 3 | 3358/120 |  | 80 |  NEW | 9 | 87 |  | — | |
| 4 | 3352/080 |  | 80 |  NEW | 10 | 88 |  | — | |
| 5 | 3354 |  | 80 |  NEW | 11 | 90 |  | — | |



80 kg



N.2 Fluid dampers
N.2 Fermi ammortizzati Fluid



Ball bearings
Cuscinetti a sfera

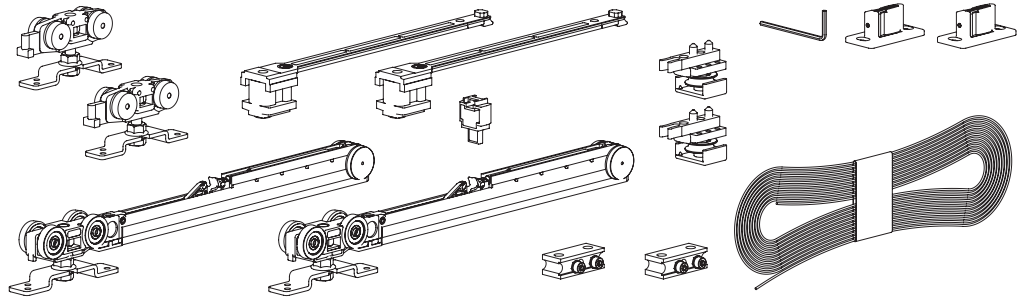

| OLD CODE | NEW CODE | MIN |
|----------|----------|-----|
| - | K.0131.6 | 1x |

N.2 Fluid dampers
N.2 Fermi ammortizzati Fluid

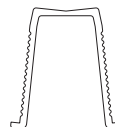
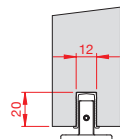
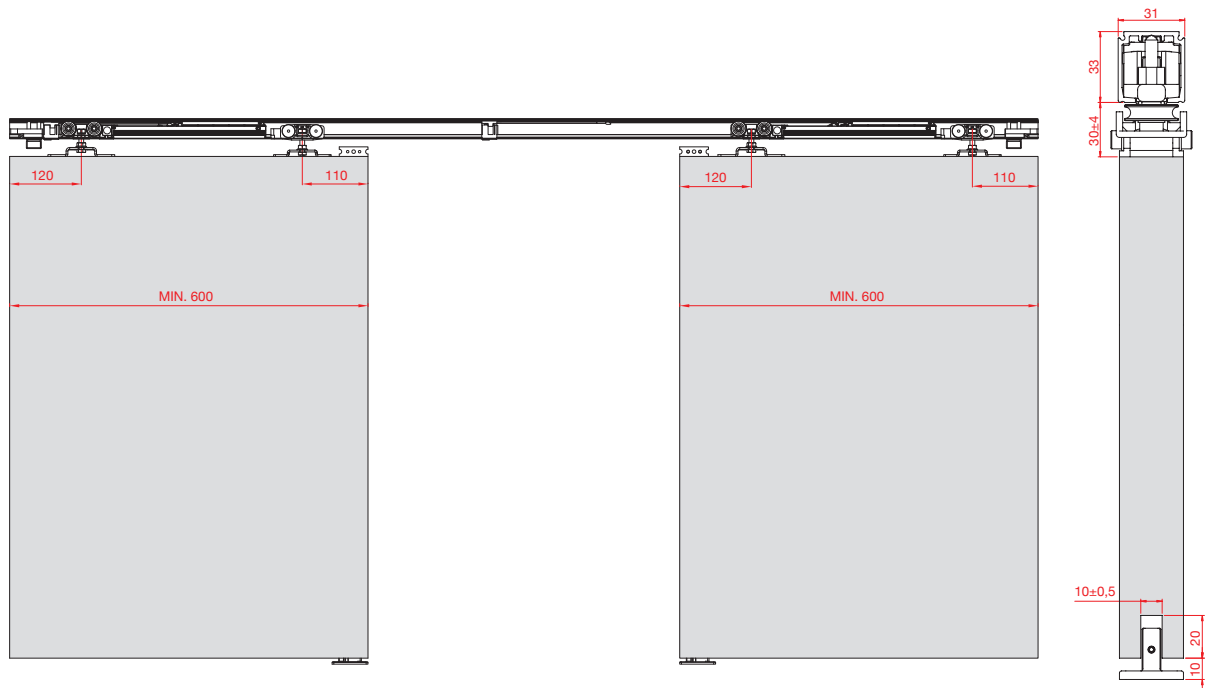



LOWER TRACK / BINARIO INFERIORE

ART. 121

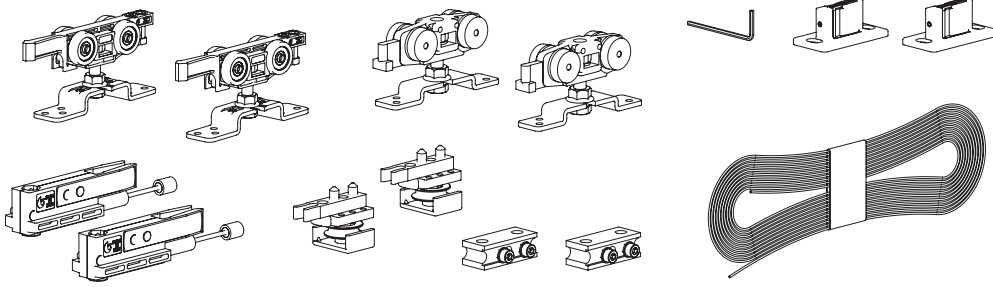
8 23 0.00121



-  **80 kg**
-  N.2 Shock absorber
N.2 Fermi a pinza ammortizzati
-  Ball bearings
Cuscinetti a sfera

| OLD CODE | NEW CODE |  |
|----------|----------|---|
| - | K.0131.7 | 1x |

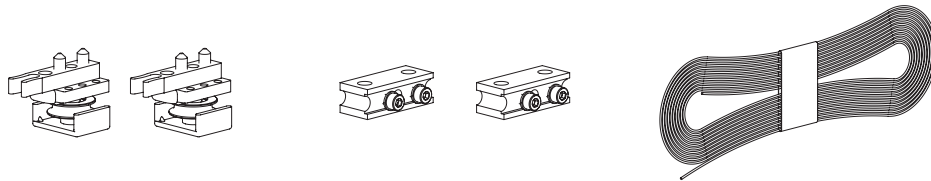

-  **80 kg**
-  N.2 Standard stoppers
N.2 Fermi standard

| OLD CODE | NEW CODE |  |
|----------|----------|---|
| 86/87/88 | K.0132.0 | 1x |

N.2 Shock absorber
N.2 Fermi a pinza ammortizzati

N.2 Standard stoppers
N.2 Fermi standard

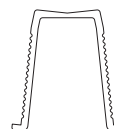
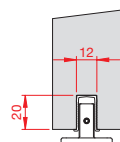
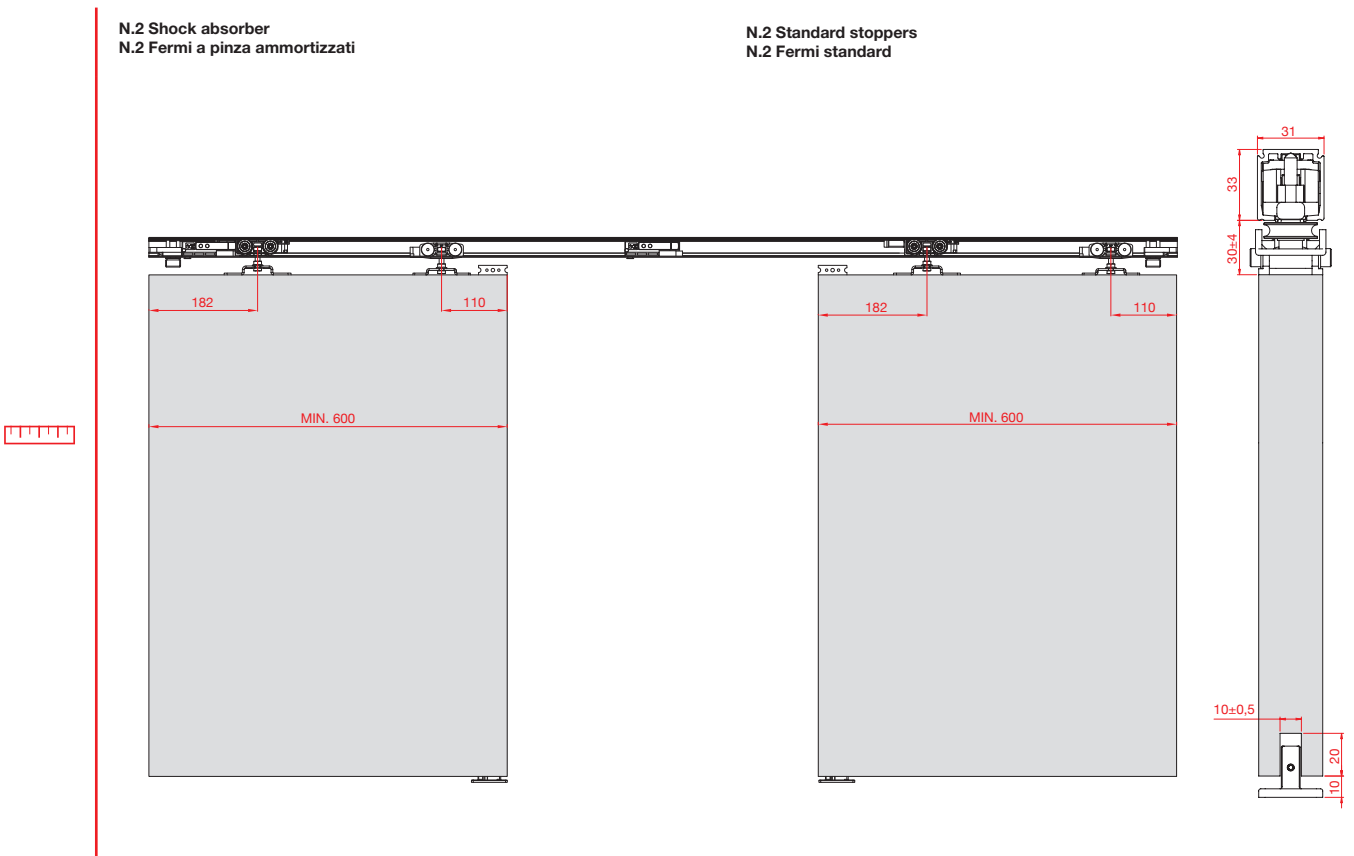













LOWER TRACK / BINARIO INFERIORE

ART. 121

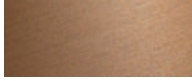
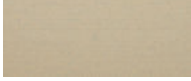

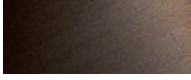
8 23 0.00121

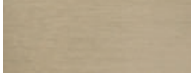
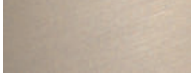

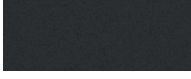
ALUMINUM FINISHES / FINITURE ALLUMINIO

| STANDARD | STANDARD | | |
|--|---|---|---|
| |  |  |  |
| 00 G Raw / Mill Finish Neutro / Grezzo | 01 A Anodized Silver Argento | 02 AS Brushed Anodized Silver Argento Spazzolato | |
| SPECIAL |  |  |  |
| | 03 AT Anodized Titanium Acciaio Titanio | 07 BRILL Anodized Brill Brill | 08 BR Anodized Bronze Bronze |
| |  |  |  |
| | 09 BRS Brushed Anodized Bronze Bronze Spazzolato | 10 CH Anodized Champagne Champagne | 11 CHS Brushed Anodized Champagne Champagne Spazzolato |
| |  |  |  |
| | 12 E3 Anodized Dark Brown E3 | 13 E3S Brushed Anodized Dark Brown E3 Spazzolato | 14 N Anodized Black Nero |
| |  |  |  |
| | 15 NS Brushed Anodized Black Nero Spazzolato | 16 NK Anodized Nickel Nichel | 17 NKS Brushed Anodized Nickel Nichel Spazzolato |
| |  |  | |
| | 25 GRFS Brushed Anodized Graphite Grafite Spazzolato | 26 GRF Anodized Graphite Grafite | |

PLASTIC FINISHES / FINITURE PLASTICA

| STANDARD | STANDARD | |
|-----------------------------|---|---|
| |  |  |
| 23 GR Gray Grigio | 14 N Anodized Black Nero | |

SAMPLES AVAILABLE UPON REQUEST / CAMPIONARIO A RICHIESTA

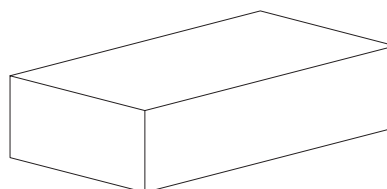

ART. KIT ALUMINIUM FINITURE / ART. KIT FINITURA ALLUMINIO

Terms of sale / Condizioni di vendita

CONDIZIONI DI VENDITA / GARANZIA

Tutte le vendite dei prodotti della Terno Scorrevoli al Compratore sono disciplinate dalle presenti Condizioni Generali (le quali gli verranno inviate per la firma, al momento dell'emissione del primo ordine, unitamente alla documentazione relativa alla privacy) e pertanto il Compratore dovrà restituire, alla Terno Scorrevoli, una copia di tali Condizioni Generali debitamente sottoscritta dal proprio legale rappresentante negli appositi spazi in calce.

1) La Terno Scorrevoli accetterà l'ordine inviando al Compratore la conferma d'ordine: in tal modo, si perfezionerà il contratto di vendita e il relativo ordine diverrà esecutivo.

2) I prezzi dei prodotti venduti saranno quelli desumibili dal listino della Terno Scorrevoli vigente al momento dell'ordine. Salvo che le parti concordino diversamente per iscritto, le scadenze delle ricevute bancarie al 31/8 e al 31/12 di ogni anno saranno posticipate rispettivamente al 10/9 e al 10/1, fermo restando tutte le altre scadenze concordate dalle parti. In caso di ritardato pagamento, alla Terno Scorrevoli spetteranno automaticamente gli interessi moratori previsti dal d. lgs. 9/11/12 n. 192 a partire dalla data di scadenza. La presenza di insoluti comporterà il blocco degli ordini in corso che saranno evasi dopo aver ricevuto il pagamento di tali pendenze, dopo che saranno acquistate le materie prime e dopo il loro relativo approntamento.

3) La consegna avverrà franco nostra fabbrica: pertanto, la consegna dei prodotti si intenderà perfezionata al momento della rimessione della merce agli spedizionieri o direttamente al Compratore presso la sede della Terno Scorrevoli, mentre le spese e i rischi dell'eventuale trasporto saranno a carico del Compratore stesso.

4) La garanzia per gli eventuali vizi o difetti dei prodotti oggetto di vendita diretta ai clienti non consumatori avrà la durata di 12 mesi a partire dalla data di consegna. Il termine per la denuncia dei vizi alla Terno Scorrevoli è di 8 giorni decorrente, quanto ai vizi apparenti, dalla data di consegna e, quanto ai vizi occulti, dalla data della loro scoperta. Sul prodotto finito è ammessa una difettosità del 2%, salvo diverso accordo scritto tra le parti. Non si accettano ritorni di merce se non dietro autorizzazione della Terno Scorrevoli e franco suo stabilimento.

5) Il presente rapporto è disciplinato dalla legge italiana. Per qualsiasi controversia relativa all'interpretazione, validità, esecuzione o risoluzione del presente rapporto di vendita sarà esclusivamente competente il Tribunale di Monza.

6) La Terno Scorrevoli si riserva di liberamente modificare qualunque tipo di articolo a catalogo al fine di migliorarlo e pertanto il Compratore è tenuto, sotto la sua responsabilità, a verificare le esatte caratteristiche tecniche dei prodotti che intende acquistare prima dell'emissione del relativo ordine.

7) La Terno Scorrevoli non si ritiene responsabile in caso di malfunzionamento o danni causati dall'utilizzo improprio o dalla manomissione dei propri prodotti. L'utilizzo dei prodotti Terno Scorrevoli in abbinamento con componenti di altri produttori viene considerato utilizzo improprio dei prodotti venduti.

8) Minimo fatturabile per i clienti residenti nella Nazione Italia €. 250,00 Netto – Per ordini inferiori le spese di gestione sono pari ad €. 20,00 Netto. Riduzione del pagamento a riba a 30 gg df fm.

Per le Nazioni UE €. 500,00 Netto.

Per le Nazioni extra UE €. 1000,00 Netto.

CONDITIONS OF SALE / WARRANTY

All sales of Terno Scorrevoli products to buyers are governed by the present General Conditions (which shall be forwarded for signature at the time of reception of the first order, together with the documentation relative to confidentiality) and the Buyer must return a copy of the same to Terno Scorrevoli, duly signed for approval by a legal representative in the apposite spaces.

1) Terno Scorrevoli shall accept the order by sending the Buyer an order confirmation: in this way, the sales contract shall be complete and the relative order shall become effective.

2) The prices of the items sold shall be those shown in the Terno Scorrevoli Price List in force at the time of the order. Unless the parties agree otherwise in writing. The presence of unsolved will involve the block some orders current that will be evaded after receiving the payment of such slopes.

3) Consignment shall be ex our factory: the products shall therefore be consigned at the premises of Terno Scorrevoli to the respective shippers or directly to the Buyer, and the same shall be responsible for the shipping costs and transport risks.

4) Terno Scorrevoli products sold to resellers are guaranteed against eventual defects and/or malfunctions for a period of 12 months from

the date of consignment. Directly observable defects must be reported to Terno Scorrevoli within 8 days of the date of consignment and non-observable defects must be reported within 2 months of their discovery. Finished products may be defective up to 2%, unless otherwise agreed upon between the parties in writing. Returns shall only be accepted if previously authorized by Terno Scorrevoli and only at its premises.

5) The present Conditions of Sale are regulated by Italian law. Any and all disputes or controversy related to the interpretation, execution or resolution of the present sales contract shall come under the exclusive jurisdiction of the Tribunal of Monza.

6) Terno Scorrevoli reserves the right to modify any of its articles in order to carry out an improvement.

7) Terno Scorrevoli will be not liable for malfunctioning or damages caused by the improper use of Terno Scorrevoli's products. The use of Terno Scorrevoli SpA products in combination with components from other manufacturers is considered improper use of the products sold.

8) Minimum order amount for Italian customers is net 250.00 Euros – For smaller orders, the handling fees are net 20.00 Euros.

For EU customers minimum order amount is net 500.00 Euros.

For extra EU customers minimum order amount is net 1000.00 Euros.

CONDITIONS DE VENTE / GARANTIE

Toutes les ventes des produits de Terno Scorrevoli à l'acheteur sont régies par les présentes Conditions Générales (lesquelles lui seront envoyées pour signature au moment de la première commande, en même temps que la documentation concernant la confidentialité) et par conséquent l'acheteur devra renvoyer à Terno Scorrevoli un exemplaire de ces Conditions Générales dûment signé par son représentant légal dans les espaces prévus à cet effet à la fin de ce document.

1) La société Terno Scorrevoli acceptera la commande en envoyant la confirmation de commande à l'acheteur: le contrat de vente sera conclu de cette manière et la commande correspondante deviendra exécutoire.

2) Les prix des produits vendus seront ceux de la liste de prix de Terno Scorrevoli en vigueur au moment de la commande. Sauf diversement convenu entre les parties par écrit. La présence de la volonté inexplicitée implique le bloc qu'une partie commande le courant qui sera évité après avoir reçu le paiement des pentes telles.

3) La livraison sera franco notre usine: par conséquent, les produits seront remis, au siège de Terno Scorrevoli, aux expéditeurs correspondants ou directement à l'acheteur, alors que les frais et les risques du transport seront à la charge de l'acheteur.

4) La garantie pour d'éventuels vices ou défauts des produits faisant l'objet d'une vente directe aux clients non consommateurs aura une durée de 12 mois à compter de la date de livraison. Le délai pour la dénonciation de vices à Terno Scorrevoli est de 8 jours courant, pour les vices apparents, à partir de la date de livraison et pour les vices cachés à compter de la date de leur constatation. Il est admis un pourcentage de 2 % de défaut sur les produits finis, sauf accord écrit entre les parties. Aucun retour de marchandise ne sera accepté sans autorisation de Terno Scorrevoli et ils seront effectués franco ses établissements.

5) Le présent rapport est régi par la loi italienne. Pour tout litige concernant l'interprétation, la validité, l'exécution ou la résolution de ce rapport de vente le Tribunal de Monza sera exclusivement compétent.

6) Terno Scorrevoli se réserve la faculté de modifier tout type d'article dans le but de son amélioration.

7) La société Terno Scorrevoli n'est pas responsable d'un mauvais fonctionnement ou d'éventuels dommages causés par l'usage improprie des articles Terno Scorrevoli. L'utilisation des produits Terno Scorrevoli SpA en combinaison avec composants d'autres fabricants est considéré comme une utilisation inappropriée des produits vendus.

8) Minimum factorable pour les client Italien: 250 € nets – Pour des commandes inférieures, les frais de gestion s'élèvent à 20 € nets. Minimum factorable pour les client EU: 500 € nets.

Minimum factorable pour les client extra EU: 1000 € nets.

ALLGEMEINE VERKAUFSBEDINGUNGEN / GARANTIE

Diese Verkaufsbedingungen gelten als eine rechtswirksame Vereinbarung zwischen dem Käufer und Terno Scorrevoli (diese Verkaufsbedingungen werden dem Käufer zur Unterschreibung bei Ausgabe des ersten Auftrags weitergereicht, zusammen mit der Dokumentation über die Mitteilung zum Datenschutz). Sie, als Käufer, sollen eine von Ihrem bevollmächtigten Vertreter unterschriebene Kopie dieser allgemeinen Verkaufsbedingungen Terno Scorrevoli zurückgeben.

1) Terno Scorrevoli wird dem Käufer eine Auftragsbestätigung überreichen, die den Verkaufsvertrag abschließt und durch die den Auftrag ausführungspflichtig wird.

Terms of sale / Condizioni di vendita

- 2) Die Preise der Produkte sind die, bei Auftragssendung geltenden, in der Preisliste von Terno Scorrevoli angeführten Preise. Die Gegenwart ungelöst schließt ein der Block bestellt ein bisschen Strom, der nach dem Erhalten der Zahlung von solchen Neigungen umgangen wird.
- 3) Warenlieferung erfolgt ab Werk. Die Produkte werden von Terno Scorrevoli den jeweils zuständigen Speditionsfirmen oder direkt dem Käufer geliefert. Frachtkosten und das Transportrisiko sind zu Lasten des Käufers.
- 4) Die Dauer der Garantie gegen Fehler und Mangel der zu den nicht Endverbraucher Kunden verkauften Produkte wird 12 Monate vom Lieferungsdatum sein. Beschwerde gegen Fehler und Mangel sollen Terno Scorrevoli innerhalb von 8 Tagen vom Lieferungsdatum spezifisch für sichtbare Fehler und vom Entdeckungsdatum für verborgene Fehler mitgeteilt werden. Eine Fehlertoleranz von 2% ist auf dem Endprodukt angenommen, wenn vertraglich schriftlich von den Parteien nicht anders vereinbart wurde. Warenrückgabe ist nur erstattet nach vorheriger erhaltener Zustimmung von Terno Scorrevoli. In diesem Fall sind die Frachtkosten für die Rückgabe zu Lasten des Käufers.
- 5) Dieser Vertrag unterliegt italienischem Recht. Für jede Rechtsfrage über die Interpretation, Gültigkeit, Ausführung und Auflösung des Vertrages ist ausschließlich das Gericht von Monza zuständig.
- 6) Terno Scorrevoli behält sich das Recht vor, jedes Produkt zu ändern, um Verbesserung zu verfolgen.
- 7) Das Unternehmen Terno Scorrevoli haftet auf keinen Fall bei Funktionsstörungen oder Schäden, die während eines unsachgemäßen Transportes der Terno Scorrevoli Produkte, verursacht wurden. Die Verwendung von Produkten von Terno Scorrevoli SpA in Kombination mit Komponenten anderer Hersteller gilt als nicht bestimmungsgemäße Verwendung der verkauften Produkte.
- 8) Geringster Rechnungsbetrag für Italien Kunden €. 250,00 Netto – Bei geringeren Bestellungen werden Verwaltungskosten von €. 20,00 Netto verrechnet.
Geringster Rechnungsbetrag für EU Kunden €. 500,00 Netto.
Geringster Rechnungsbetrag für extra EU Kunden €. 1000,00 Netto.

CONDICIONES GENERALES DE VENTA / GARANTÍA

Todas las ventas de los productos de Terno Scorrevoli al Comprador están reguladas por las presentes Condiciones Generales (las cuales se enviarán para ser firmadas en el momento de la emisión del primer pedido, junto a la documentación relativa a la privacidad) y por tanto el Comprador tendrá que devolver a Terno Scorrevoli, una copia de dichas Condiciones Generales debidamente firmada por su representante legal en los correspondientes espacios a pie de página.

1) Terno Scorrevoli aceptará el pedido enviando al Comprador la confirmación del mismo: de esta forma se perfeccionará el contrato de venta y el relativo pedido será ejecutivo.

- 2) Los precios de los productos vendidos serán los presentados en el listín de precios de Terno Scorrevoli vigente en el momento del pedido. Excepto en el caso de que las partes tomen un acuerdo diferente por escrito. La presencia de voluntad sin resolver implica el bloque que una parte pide corriente que se eludirá después de recibir el pago de inclinaciones tales.
- 3) La entrega se realizará franco nuestra fábrica: es decir, los productos se entregarán en la sede de Terno Scorrevoli a los respectivos transportistas o directamente al Comprador, por tanto los gastos y los riesgos del transporte serán a cargo del Comprador.
- 4) La garantía por eventuales fallos o defectos de los productos objeto de la venta directa a los clientes no consumidores tendrá una duración de 12 meses a partir de la fecha de entrega. El plazo para denunciar los fallos a Terno Scorrevoli, por lo que se refiere a los fallos aparentes, es de 8 a partir de la fecha de entrega y, respecto a los fallos ocultos, a partir de la fecha de su descubrimiento. Respecto al producto acabado se admite un porcentaje de defecto del 2%, excepto un diferente acuerdo escrito entre las partes. No se aceptan devoluciones de mercancías sin la previa autorización de Terno Scorrevoli y franco fábrica del Cliente.
- 5) La presente relación está regulada por la ley italiana. Para cualquier controversia relativa a la interpretación, validez, ejecución o resolución de la presente relación de venta será competente exclusivamente el Tribunal de Monza.
- 6) Terno Scorrevoli se reserva el derecho de poder modificar cualquier tipo de artículo con el fin de obtener una mejora.
- 7) La Terno Scorrevoli no se responsabiliza en caso de mal funcionamiento o daños causados por el uso impropio de los productos Terno Scorrevoli. El uso de los productos Terno Scorrevoli SpA en combinación con componentes de otros fabricantes se considera uso inadecuado de los productos vendidos.
- 8) Mínimo facturable para clientes italianos €. 250,00 netos – Para pedidos de menor valor los gastos de gestión son de € 20,00 netos.
Mínimo facturable para clientes EU €. 500,00 netos.
Mínimo facturable para clientes extra EU €. 1000,00 netos.

SCADENZE R.B.

Al 31/8 e al 31/12 posticipo al 10/09 e al 10/01 successivo fermo restando le altre scadenze a tutti gli ordini segue nostra conferma d'ordine, **Pertanto ci solleviamo da eventuali vostri reclami per errate quantità, prezzi, articoli, forature, misure, etc.**

Unaccepted trade bills due date of 31/08 and 31/12 deferred to 10/09 and 10/01, all other maturity dates remain unchanged.

We issue confirmations for orders and thus are not liable for any mistakes in quantities, prices, articles, holes, measurements, etc.

TERNO SCORREVOLI si riserva di poter modificare qualunque tipo di articolo al fine di ottenere un miglioramento.

TERNO SCORREVOLI has the right of modifying and improving any of its articles.

TERNO SCORREVOLI se réserve le droit d'apporter des modifications à n'importe quel article susceptibles d'entraîner une amélioration.

TERNO SCORREVOLI behält sich das Recht vor, jeden Artikel für Verbesserungen verändern zu können.

TERNO SCORREVOLI se reserva el derecho de modificar cualquier artículo con el fin de mejorarlo.



Trave

Ceiling upright bar track, wall track, suspended upright bar track
Binario a trave a soffitto, trave a parete, trave sospesa





Ceiling upright bar track

Aluminium sliding doors system with adjustable solution for wall fixing

Trave a soffitto

Scorrevoli per porte in alluminio con binario trave a soffitto regolabile



Wall track

Aluminium sliding doors system with adjustable solution for ceiling fixing

Trave a parete

Scorrevoli per porte in alluminio con binario trave a parete



Suspended upright bar track

Aluminium sliding doors system with suspended beam

Trave sospesa

Scorrevoli per porte in alluminio disponibili con binario a trave sospesa

Trave

Ceiling upright bar track
Trave a soffitto





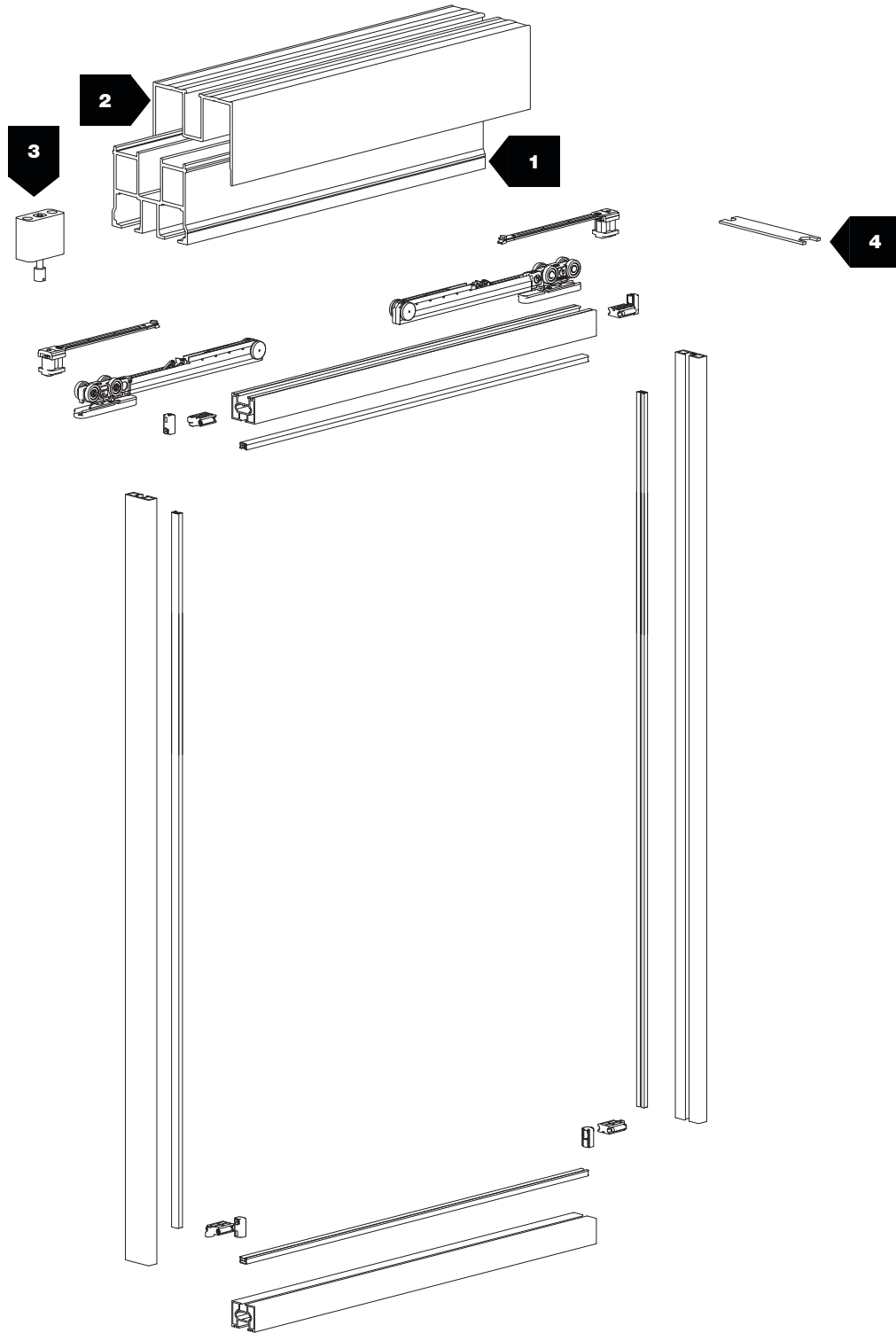



Max. 45 mm



120 kg

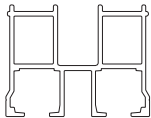
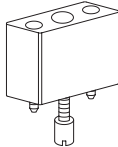
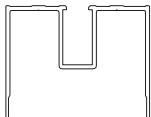

6 - 10 mm

| N° | Barcode | | kg | N° | Barcode | | kg |
|----|----------------------|---|-----|----|---------|---|-----|
| 1 | 1525 8 01 2.01525 |  | 120 | 3 | 1570 |  | 120 |
| 2 | 1535 8 02 0.01535 |  | 120 | 4 | 1029 |  | 120 |

| Tracks / Binari | | ALUMINUM FINISHES CODES / CODICI FINITURE ALLUMINIO | |  |
|-----------------|---|---|--|---|
| CODE / CODICE | | FINISH COLOR / COLORE FINITURA | | |
| 8 01 0.0 |  01 A | Anodized Silver / Argento | | STANDARD |
| 8 02 0.0 |  02 AS | Brushed Anodized Silver / Argento Spazzolato | | |

CEILING UPRIGHT BAR TRACK / TRAVE A SOFFITTO

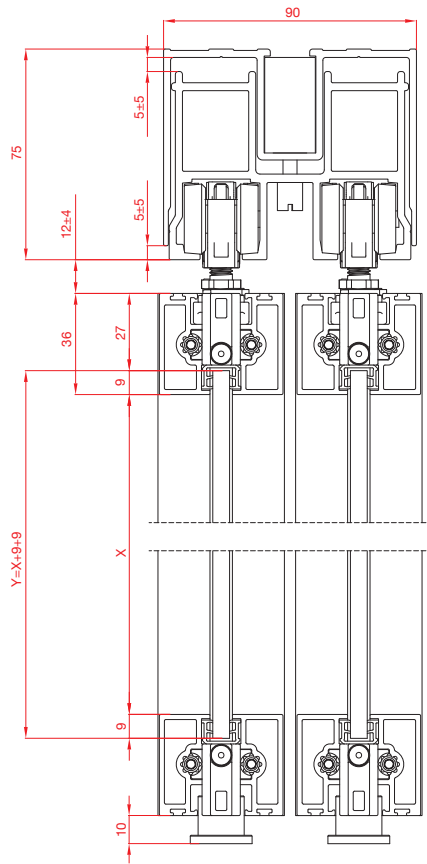

COMPATIBLE WITH / COMPATIBILE CON:

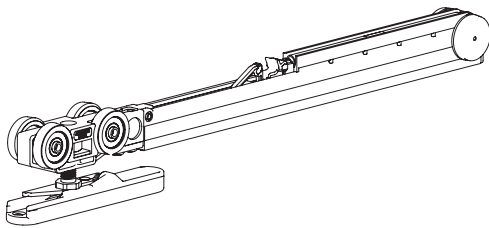

UNIVERSAL + ECLETTICA
THE NEW FRAME + LATERAL AUTOMATIC CLAMP
IL NUOVO TELAIO + STAFFA AUTOMATICA LATERALE

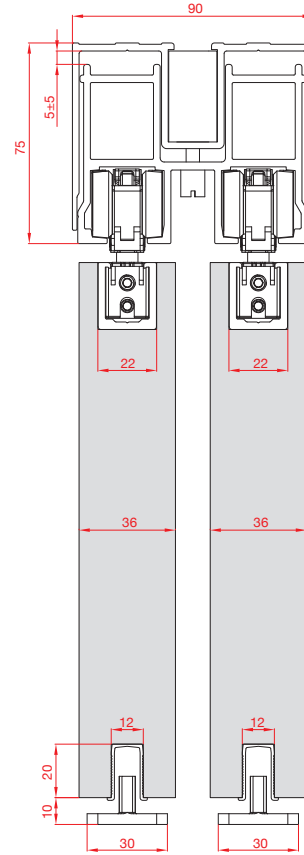

COMPATIBLE WITH / COMPATIBILE CON:

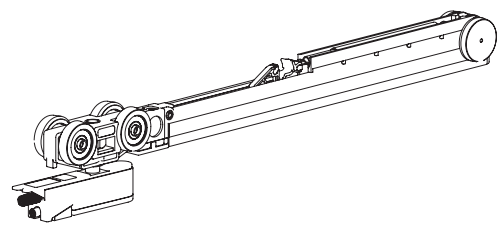

EVOLUTION
THE INVISIBLE BRACKET SLIDING SYSTEM
SISTEMA SCORREVOLE CON STAFFA INVISIBILE

Trave

Wall track
Trave a parete





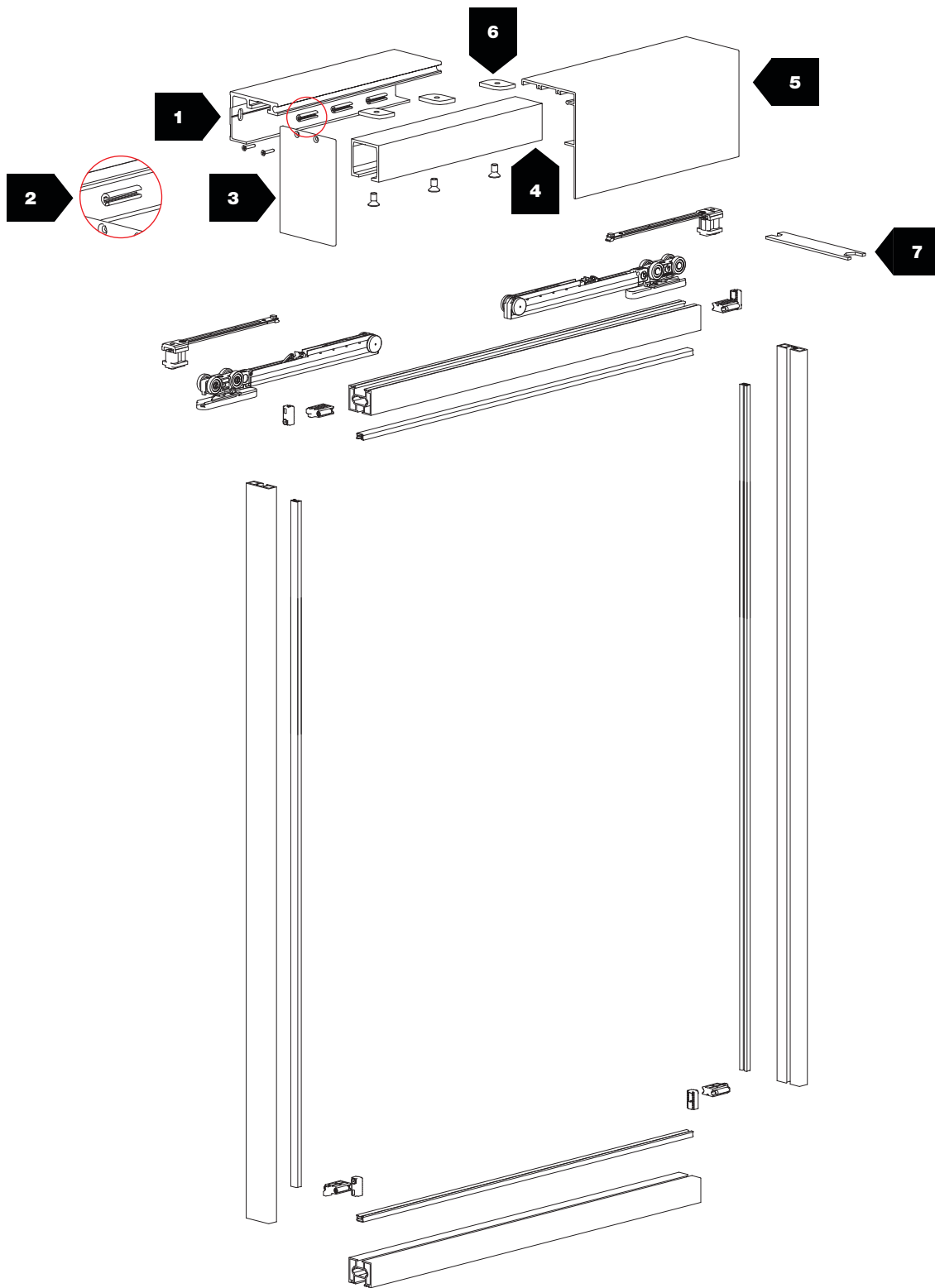







Max. 45 mm

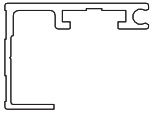
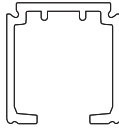

120 kg

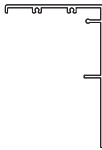
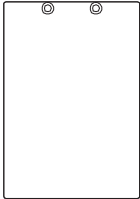

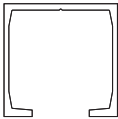
6 - 10 mm

| N° | Barcode | | kg | | N° | Barcode | | kg | |
|----|--------------------------------------|---|-----|--|----|--------------------------------------|---|-----|--|
| 1 | 1636 8 00 0.01636 8 01 0.01636 |  | 120 | | 4 | 1280 8 00 0.01280 8 01 0.01280 |  | 120 | |
| 2 | 1222 |  | 120 | | 5 | 1638 8 02 0.01638 |  | 120 | |
| 3 | 1650 |  | 120 | | 6 | 1652/10 |  | 120 | |
| 4 | 1080 8 00 0.01080 8 01 0.01080 |  | 120 | | 7 | 1029 |  | 120 | |

| Tracks / Binari | | ALUMINUM FINISHES CODES / CODICI FINITURE ALLUMINIO | |  |
|-----------------|---|---|--|---|
| CODE / CODICE | | FINISH COLOR / COLORE FINITURA | | |
| 8 00 0.0 |  00 G | Row - Mill Finish / Neutro - Grezzo | | STANDARD |
| 8 01 0.0 |  01 A | Anodized Silver / Argento | | |
| 8 02 0.0 |  02 AS | Brushed Anodized Silver / Argento Spazzolato | | |

WALL TRACK / TRAVE A PARETE

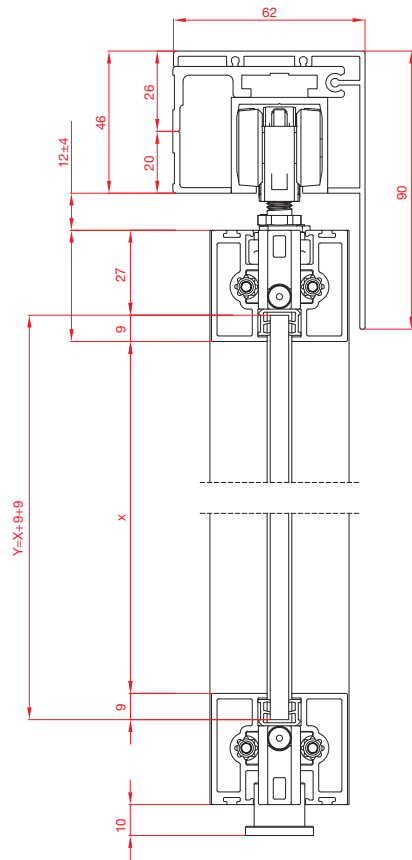

COMPATIBLE WITH / COMPATIBILE CON:

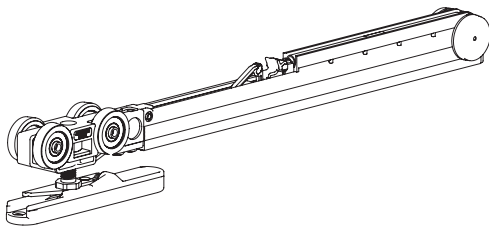

UNIVERSAL + ECLETTICA
THE NEW FRAME + LATERAL AUTOMATIC CLAMP
IL NUOVO TELAIO + STAFFA AUTOMATICA LATERALE

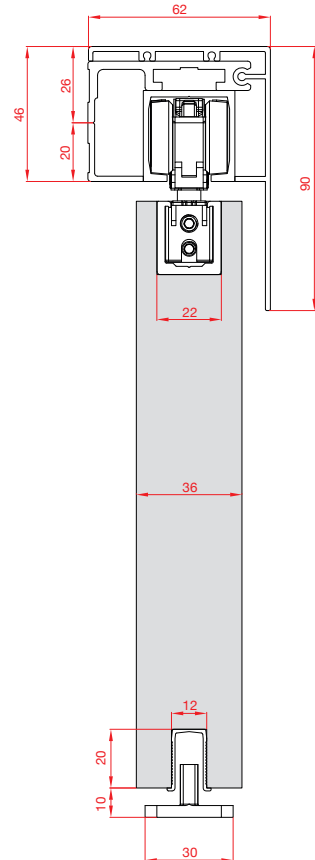

COMPATIBLE WITH / COMPATIBILE CON:

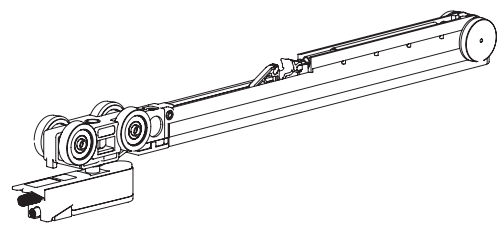

EVOLUTION
THE INVISIBLE BRACKET SLIDING SYSTEM
SISTEMA SCORREVOLE CON STAFFA INVISIBILE

Trave

Suspended upright bar track
Trave sospesa





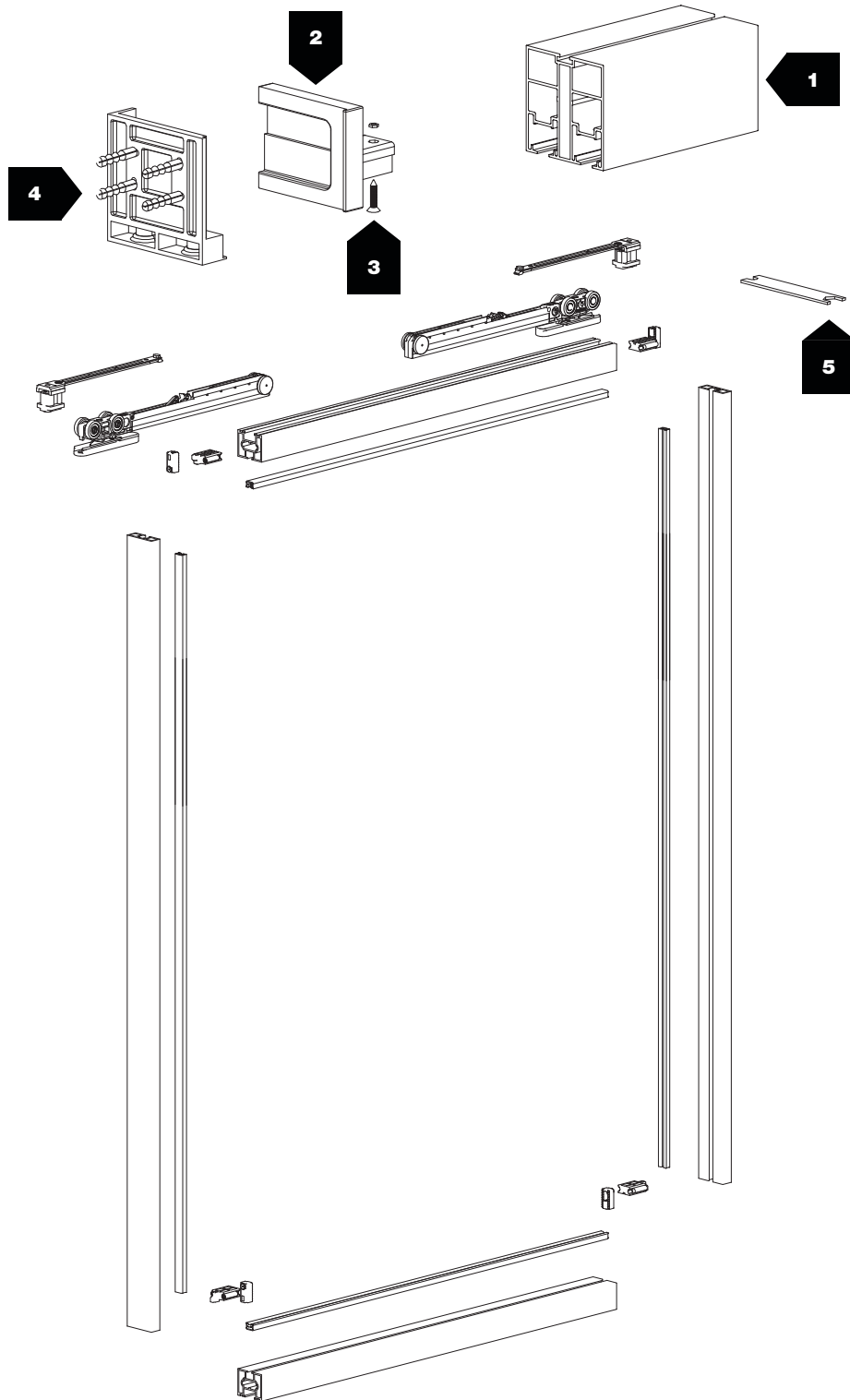



Max. 45 mm



120 kg

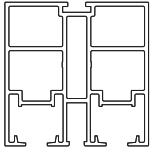
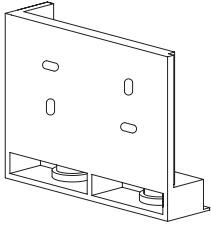
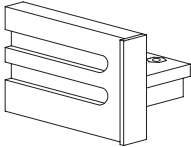

6 - 10 mm

| N° | Barcode | | kg | | N° | Barcode | | kg | |
|----|----------------------|---|-----|--|----|---------|---|-----|--|
| 1 | 1515 8 02 2.01515 |  | 120 | | 4 | 1536 |  | 120 | |
| 2 | 1538 |  | 120 | | 5 | 1029 |  | 120 | |
| 3 | M4x27TPS |  | 120 | | | | | | |

| Tracks / Binari | | ALUMINUM FINISHES CODES / CODICI FINITURE ALLUMINIO | |  |
|-----------------|---|---|--|---|
| CODE / CODICE | | FINISH COLOR / COLORE FINITURA | | |
| 8 02 0.0 |  | 02 AS | Brushed Anodized Silver / Argento Spazzolato | STANDARD |

SUSPENDED UPRIGHT BAR TRACK / TRAVE SOSPESA

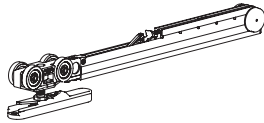
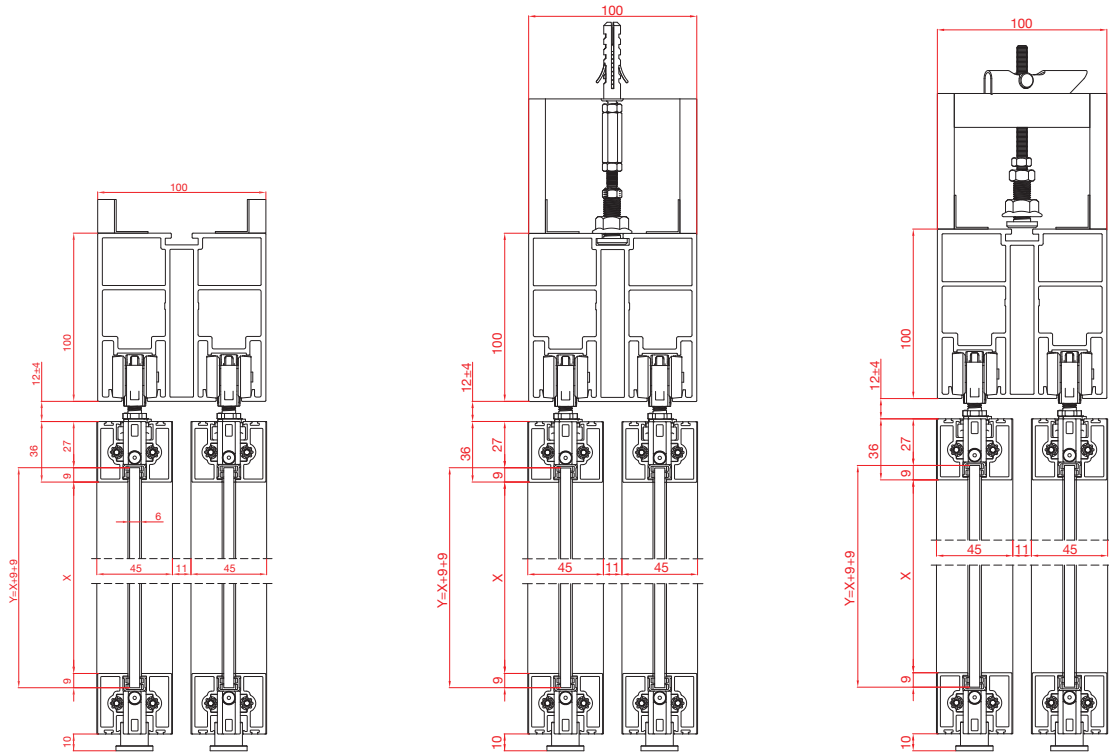

COMPATIBLE WITH / COMPATIBILE CON:

UNIVERSAL + ECLETTICA

THE NEW FRAME + LATERAL AUTOMATIC CLAMP/ IL NUOVO TELAI0 + STAFFA AUTOMATICA LATERALE

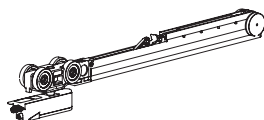
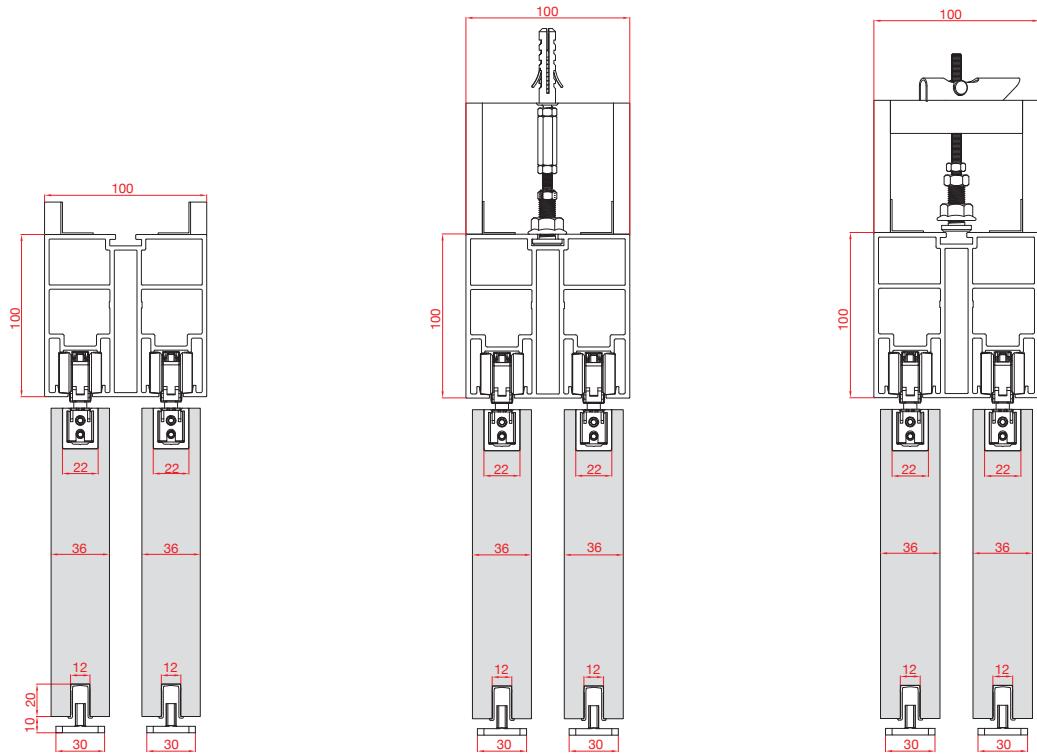

COMPATIBLE WITH / COMPATIBILE CON:

EVOLUTION

THE INVISIBLE BRACKET SLIDING SYSTEM / SISTEMA SCORREVOLE CON STAFFA INVISIBILE

ACCESSORIES / ACCESSORI

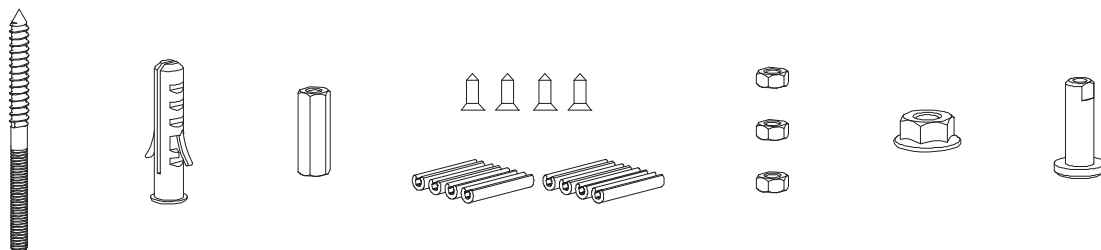

ACCESSORIES FOR FULL CEILING FIXTURE / ACCESSORI PER FISSAGGIO A SOFFITTO PIENO

ART. 2304
K.0481.1

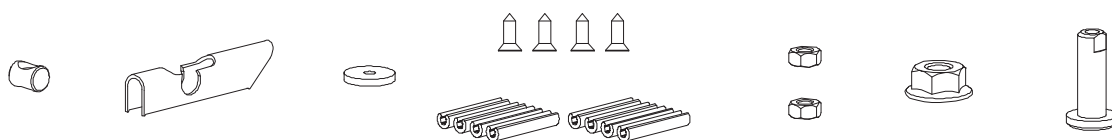

ACCESSORIES FOR EMPTY CEILING FIXTURE / ACCESSORI PER FISSAGGIO A SOFFITTO VUOTO

ART. 2306
K.0481.2

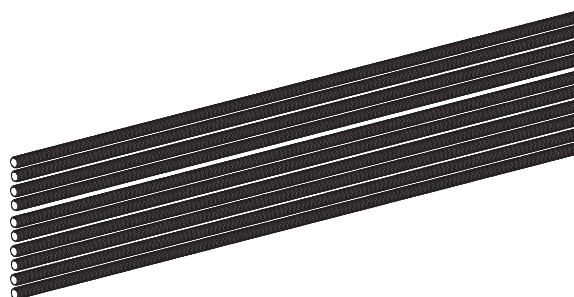

**3 METERS M6 THREADED BAR / BARRA FILETTATA M6 DA METRI 3
(KIT N° 10 PZ.)**

ART. 2308/3/10
K.0402.3

ADJUSTMENT CEILING UPRIGHT BAR TRACK WITH SUPPORT FOR DRYWALL EMPTY CEILING
REGOLAZIONE TRAVE A SOFFITTO CON SOSTEGNO PER CARTONGESSO SOFFITTO VUOTO

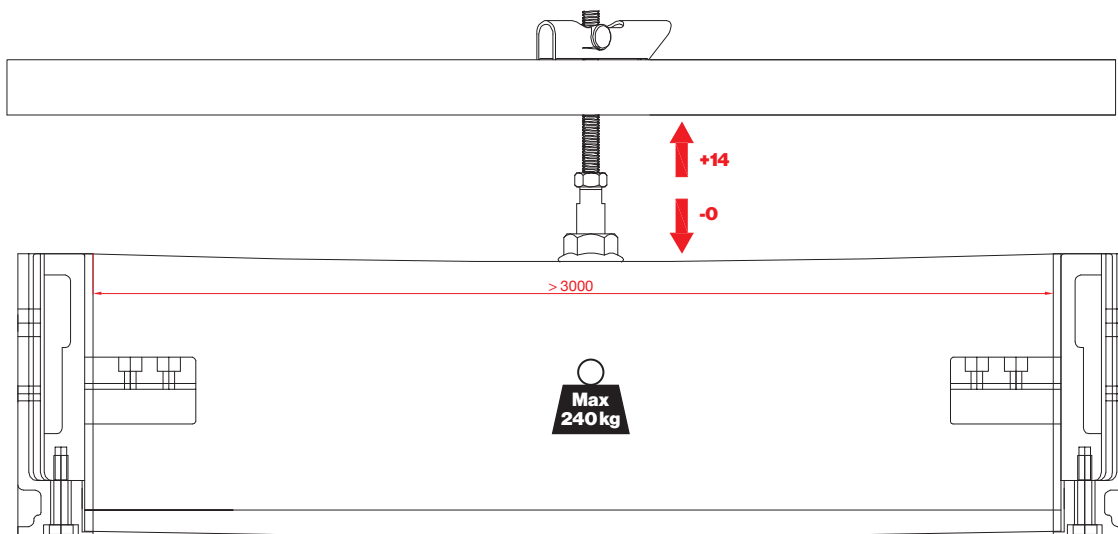

DOORS TOTAL WEIGHT: MAX 240 kg / PESO TOTALE DELLE PORTE: MAX 240 kg

ADJUSTMENT CEILING UPRIGHT BAR TRACK WITH SUPPORT FOR DRYWALL FULL CEILING
REGOLAZIONE TRAVE A SOFFITTO CON SOSTEGNO PER CARTONGESSO SOFFITTO PIENO

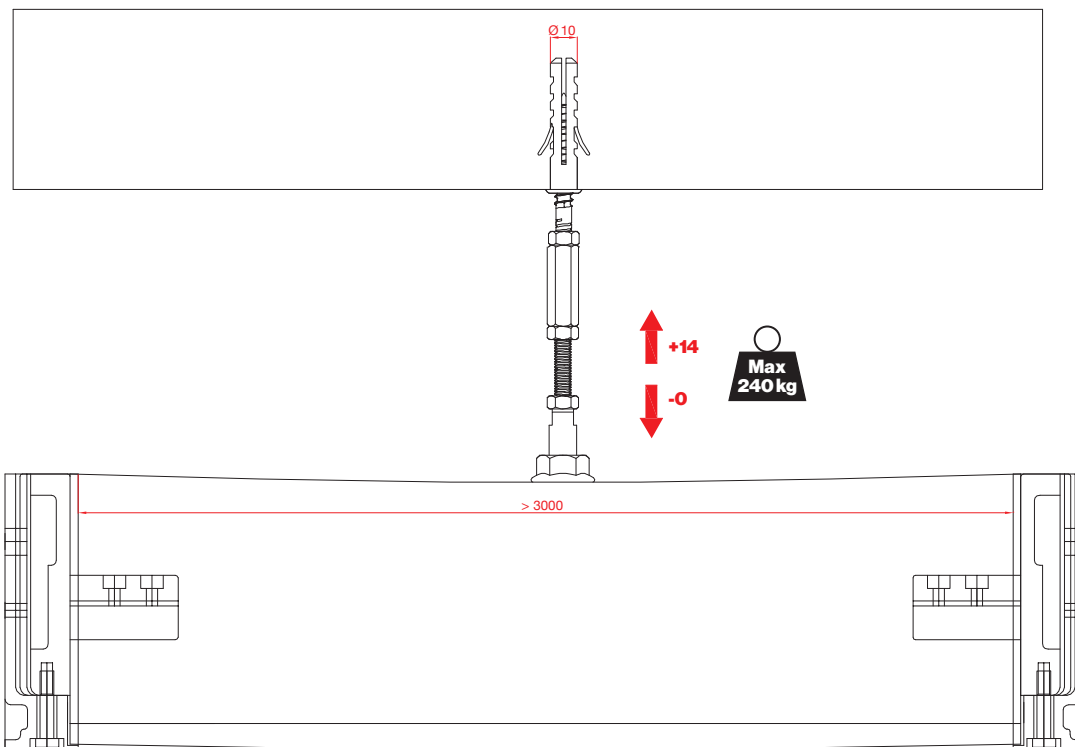

DOORS TOTAL WEIGHT: MAX 240 kg / PESO TOTALE DELLE PORTE: MAX 240 kg



Universal

The new frame for aluminium, glass and wooden doors
Il nuovo telaio per ante in alluminio, vetro e legno

www.ternoscorrevoli.com/universal

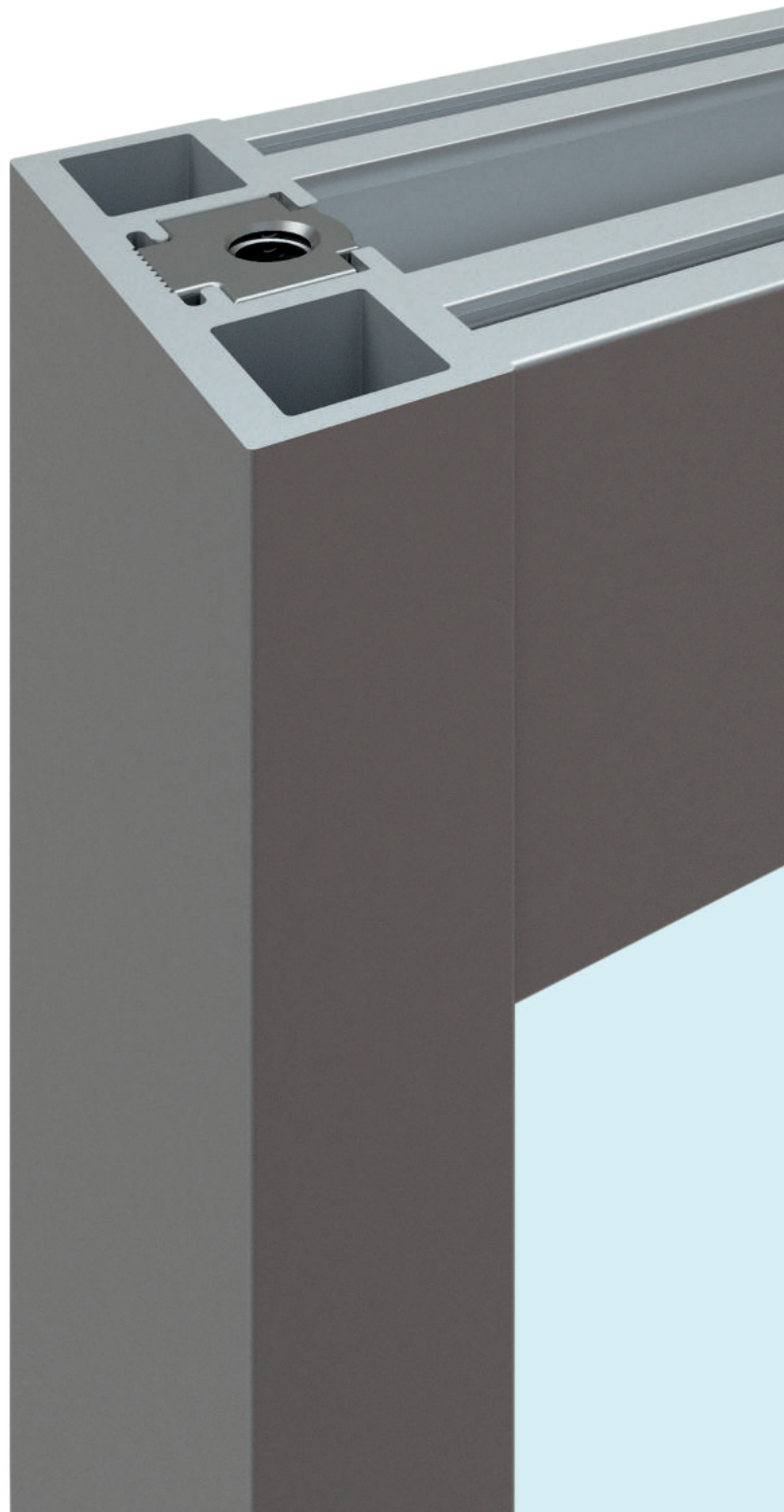



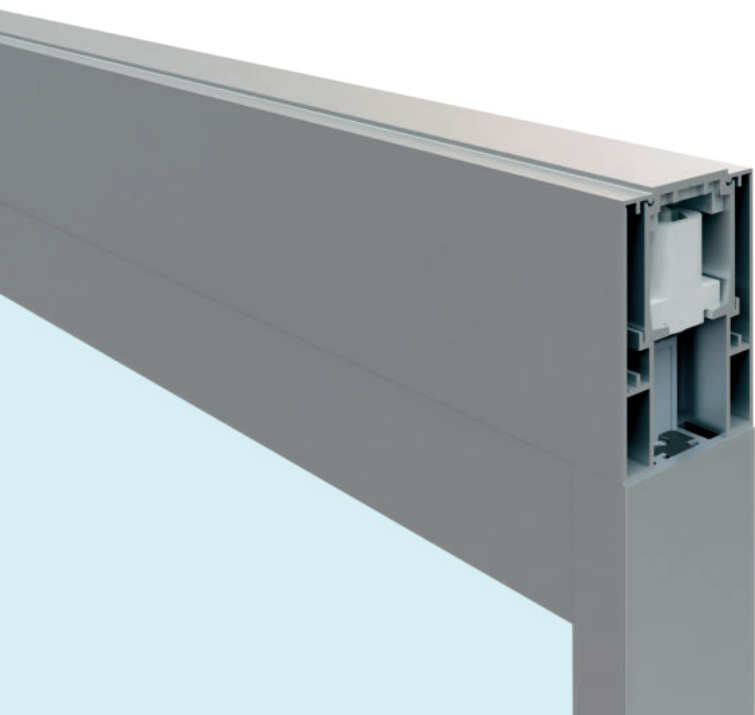

Minimal and linear design

The vertical upright with reduced dimensions will decrease visibility of extruded. Lines will then result linear and clean. The gap, in the upper side of the door as in the bottom, has been reduced to the same of a standard swing door and no additional drilling or milling processes are required. The external cover of track, aligned with the door, will shape a continuous surface. All features contribute to lend the system to an essemptial, but pleasent design.

Design pulito e lineare

Il montante verticale con dimensioni ridotte riduce la visibilità degli estrusi. Le linee risultano così lineari e pulite. La luce, sia nella parte alta che nella parte bassa della porta, è ridotta al pari di una porta battente. Non sono necessarie lavorazioni di foratura e fresatura. La copertura in alluminio e la porta formano una superficie continua: tutto concorre a conferire al nuovo telaio un design essenziale ma piacevole.

“The new UNIVERSAL frame is the perfect answer to the requirements for an elegant, performant and high resistant product”

“Il nuovo telaio UNIVERSAL è la risposta perfetta alle richieste di un prodotto elegante ma funzionale, e resistente”

The highest resistance

Tubular extruded profiles, metal joints, perfect grip, load-bearing connectors, bi-extruded gasket. All components contribute to grant the glass weigth to be sustained by vertical uprights and horizontal crosstracks, halving the pressure of it.

La massima resistenza

Estrusi tubolari, giunzioni in metallo, aderenza massima, attacchi portanti, guarnizione biestrusa: il peso del vetro è sostenuto dai montanti e dai traversi, e ne viene dimezzata la pressione.

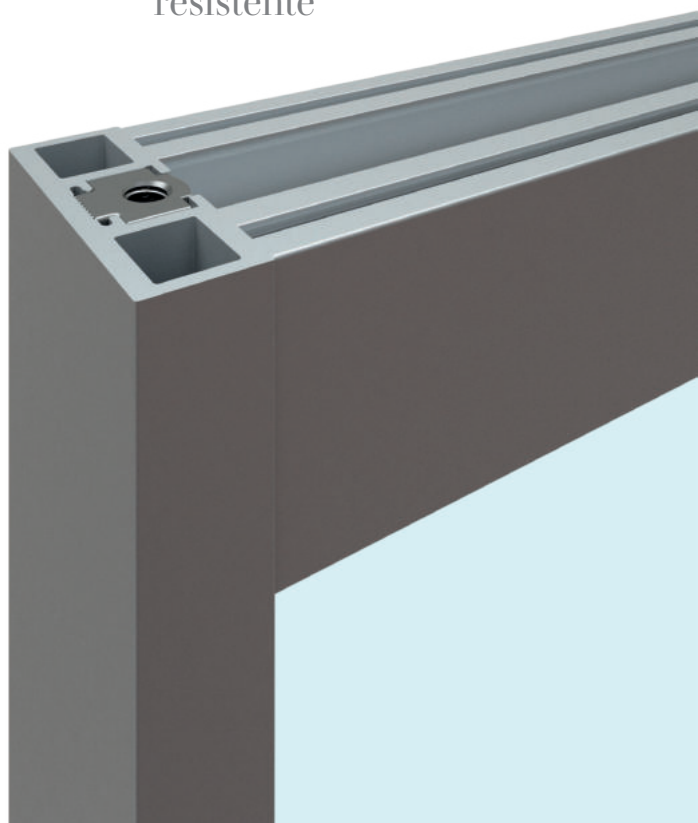



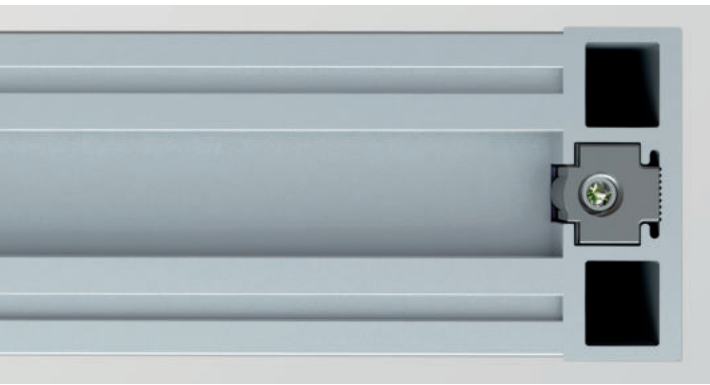

Versatility and resistance

The new frame's extruded profiles are tubular and are assembled by metal joints, without any additional drilling processing requirement. This allows to cut profiles to favourite size, without any drilling or milling process, always granting the perfect grip.

Resistenza e flessibilità

I nuovi estrusi del telaio sono tubolari, per ottenere la massima resistenza, e vengono assemblati tramite giunzione in metallo, senza necessità di lavorazioni di foratura: questo permette di tagliare la barra nella misura preferita, senza fori nè fresate, e di ottenere la massima aderenza.

Extreme versatility of material and configurations

The 45 mm thickness allows to combine fixed aluminium panels to standard sliding wooden doors. New Universal frame basically allows multiple different configurations: from the single sliding door, to the sliding door combined with two or three fixed elements or panels, the double sliding doors with or without additional fixed elements.

Estrema versatilità di materiali e configurazioni

Lo spessore da 45 mm permette di abbinare le ante in alluminio alle porte di legno standard. Le configurazioni che il telaio Universal consente di creare sono molteplici: dall'anta singola scorrevole, all'anta singola abbinata con uno o due elementi fissi, dall'anta doppia scorrevole all'anta doppia abbinata a due elementi fissi.

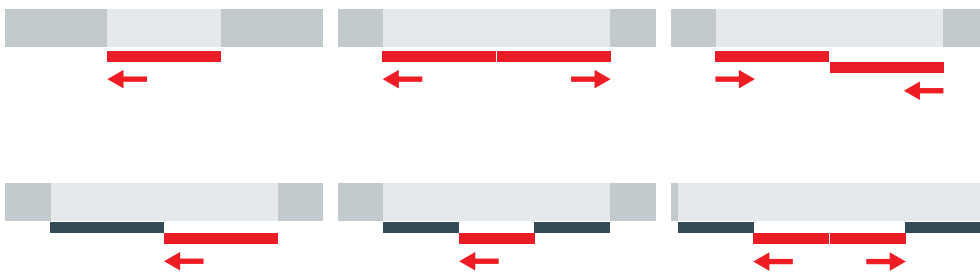
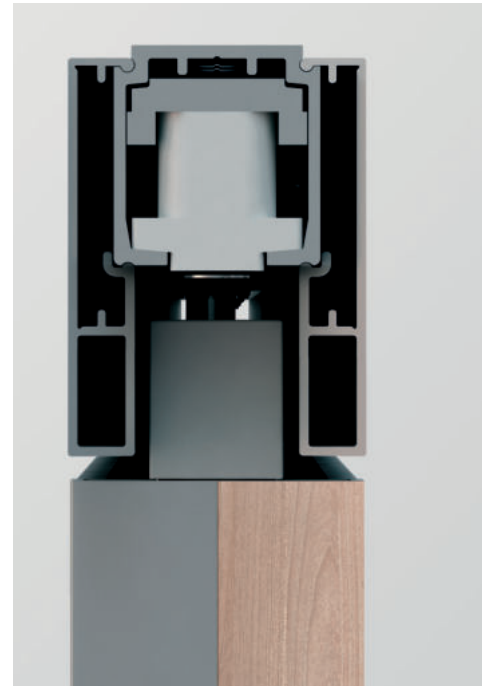

Reduced vertical and horizontal gap

Into the horizontal crosstrack are inserted dustcover brushes, allowing to fill the gap either in the bottom, as in the upper side, towards the external cover. According to that, horizontal or vertical door's gap will result extremely reduced.

Spazio di aria e di luce ridotti

Nel montante orizzontale vengono inseriti gli spazzolini parapolvere, che permettono di chiudere la luce sia nella parte inferiore che nella parte superiore, verso la copertura: lo spazio di aria e di luce risultano così estremamente ridotti.

Essential and modern design

Vertical upright has been designed with reduced dimensions in order to extremely limitate the visual impact of extruded profiles. The external cover of track, aligned with the door, will shape a continuous surface, pleasing to the eye. Profiles and accessories may also be realized in different finishings, from lighter to darker colours, as per latest design trends.

Design essenziale e moderno

Il montante verticale ha dimensioni ridotte per limitare estremamente la visibilità degli estrusi. La copertura in alluminio e la porta formano una superficie continua, piacevole alla vista. I profili e gli accessori possono inoltre essere realizzati con diversi tipi di finiture, dai colori più chiari fino a colorazioni più scure, di tendenza.

Installation in every context

Universal frame may be combined with two of bracket series already existing in Terno Scorrevoli range: **Eclettica** and **Evolution**. In combination with lateral automatic clipping bracket **Eclettica**, the new frame may be fixed on the wall, directly to the ceiling or to counterceiling. The external cover has been designed to be totally aligned to the handle, in order to shape a continuous surface to reduce as much as possible horizontal gap. Instead, combining **Universal** frame to invisible **Evolution** bracket, it is possible to perform any possible installation option, from wall to ceiling fixing, with the benefit of having a complete closure of upper horizontal gap, given that the door will be positioned in the middle of the crawlspace between the two external covers, closing the upper gap at 100% and keeping sliding elements totally hidden.

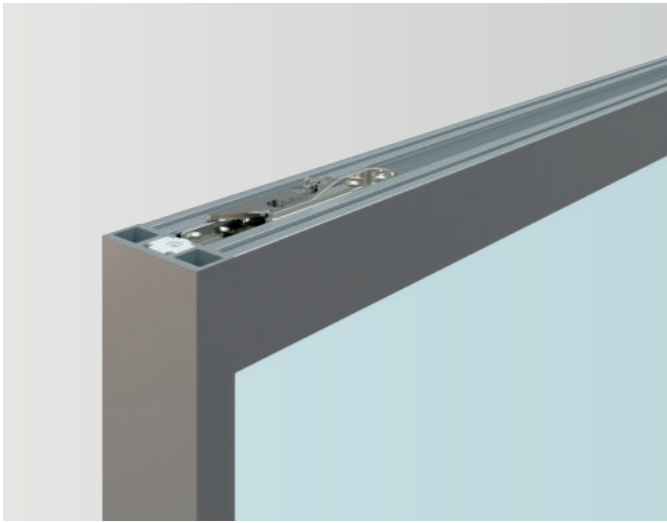

Installazione in ogni contesto

Il telaio **Universal** si può utilizzare con due staffe già presenti nel catalogo Terno Scorrevoli: la staffa **Eclettica** e la staffa **Evolution**. Combinato con la staffa automatica laterale **Eclettica**, il nuovo telaio può essere installato sia a parete che a soffitto, che a controsoffitto. La copertura in alluminio è stata disegnata per essere allineata completamente alla maniglia, definendo così una superficie unica e continua che riduce al minimo la luce. Combinando invece il telaio **Universal** alla staffa invisibile **Evolution**, si ottengono tutte le soluzioni possibili a parete e a soffitto, con il vantaggio di avere una chiusura totale della luce: la porta si inserisce nell'intercapedine delle due coperture e la luce è così chiusa al 100%, e i meccanismi di scorrimento sono completamente nascosti.

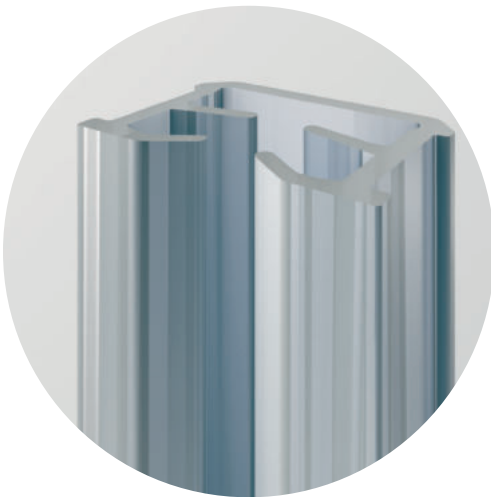
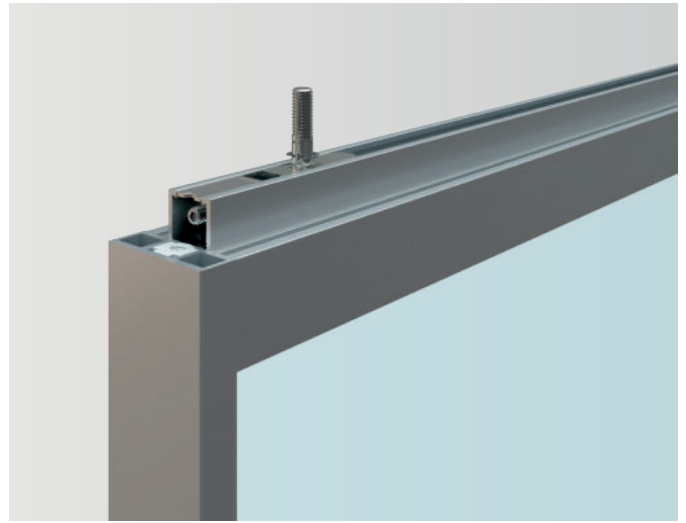

Dedicated to monolithic and laminated glass

Thanks to innovative extruded profiles, **Universal** frame results to be highly resistant. Furthermore, it has been realized an innovative bi-extruded gasket which allows an optimal grip of glass. The bi-extruded gasket will allow to use monolithic and laminated glasses from 5 up to 6,5 mm thickness.

Per vetri monolitici o stratificati

Grazie agli innovativi estrusi, il telaio **Universal** risulta molto resistente. È stata realizzata, inoltre, un'innovativa guarnizione biestrusa che permette un'ottimale tenuta del vetro. Con questa guarnizione, è possibile montare vetri monolitici o laminati con spessori da 5 a 6,5 mm.

Load-bearing crosstracks



The metal joint connector which hold the crosstrack it is not acting only as a divider, but it also has a load-bearing function, in order to uniformly distribute the glass weight along vertical uprights and horizontal crosstracks, halving the pressure of it and allowing to realize larger surfaces.



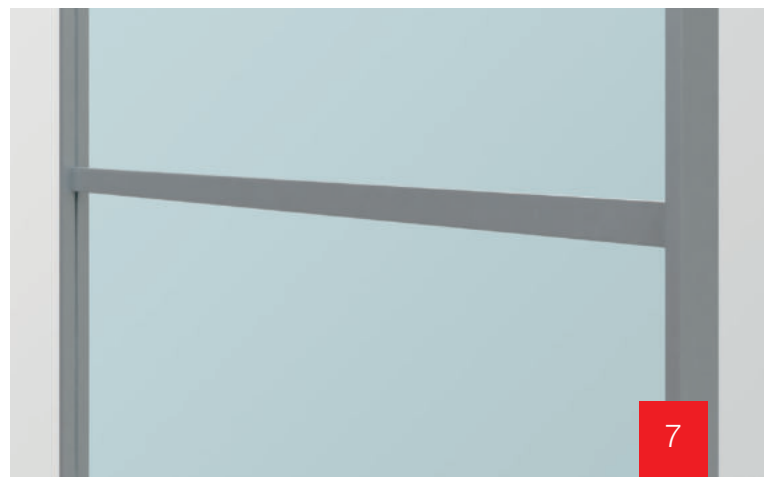



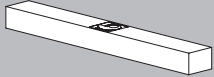

Traversi portanti

L'attacco metallico che sostiene il traverso non funge solo da divisorio, ma è portante: questo vuol dire che il peso del vetro è distribuito uniformemente su montanti e traversi, dimezzandone la pressione, e permettendo di creare superfici più grandi.



| Tracks / Binari | | ALUMINUM FINISHES CODES / CODICI FINITURE ALLUMINIO | |  |
|-----------------|---|---|--|---|
| CODE / CODICE | | FINISH COLOR / COLORE FINITURA | | |
| 8 01 0.0 |  01 A | Anodized Silver / Argento | | STANDARD |
| 8 02 0.0 |  02 AS | Brushed Anodized Silver / Argento Spazzolato | | |
| 8 13 0.0 |  13 E3S | Brushed Anodized Dark Brown / E3 Spazzolato | | SPECIAL |
| 8 15 0.0 |  15 NS | Brushed Anodized Black / Nero Spazzolato | | |
| 8 17 0.0 |  17 NKS | Brushed Anodized Nickel / Nichel Spazzolato | | |
| 8 25 0.0 |  25 GRFS | Brushed Anodized Graphite / Grafite Spazzolato | | |

| Tracks / Binari | | PLASTIC FINISHES CODES / CODICI FINITURE PLASTICA | |  |
|-----------------|---|---|--|---|
| CODE / CODICE | | FINISH COLOR / COLORE FINITURA | | |
| 8 23 0.0 |  23 GR | Gray / Grigio | | STANDARD |

| Universal | | COMPLETE BOX KIT / KIT COMPLETO IN SCATOLA | |  |
|-----------|---|--|---|---|
| K | Complete kit / Kit completo | | | |
| 0421 |  Kit Universal + Evolution (Aluminium / Alluminio) | | | |
| 0422 |  Kit Universal + Evolution (Fix Aluminium Door / Porta fissa in Alluminio) | | | |
| 0423 |  Kit Universal + Eclettica (Aluminium / Alluminio) | | | |
| 0424 |  Kit Universal + Eclettica (Fix Aluminium Door / Porta fissa in Alluminio) | | | |
| 0425 |  Kit Universal + Evolution (Wood / Legno) | | | |
| 0426 |  Kit Universal + Evolution (Fix Wooden Door / Porta fissa in Legno) | | | |
| 0427 |  Kit Universal + Eclettica (Wood / Legno) | | | |
| 0428 |  Kit Universal + Eclettica (Fix Wooden Door / Porta fissa in Legno) | | | |
| | | | | |
| | | 0 | N.2 Standard stoppers N.2 Fermi standard | |
| | | 1 | N.2 Fluid dampers N.2 Fermi ammortizzati Fluid Eclettica | |
| | | 2 | N.2 Fluid dampers N.2 Fermi ammortizzati Fluid Evolution | |
| | | | | |
| | | 0 | Multi measurement Multimisura | |
| | | 1 | 2200x1000 mm | |
| | | 2 | 2600x1200 mm | |
| | | 3 | 3000x1500 mm | |
| | | 4 | W = 1000 mm | |
| | | 5 | W = 1200 mm | |
| | | 6 | W = 1500 mm | |
| | | | | |
| | | 02 | Brushed Anodized Silver Argento Spazzolato | |
| | | 13 | Brushed Anodized Dark Brown E3 Spazzolato | |
| | | 15 | Brushed Anodized Black Nero Spazzolato | |
| | | 17 | Brushed Anodized Nickel Nichel Spazzolato | |
| | | 25 | Brushed Anodized Graphite Grafite Spazzolato | |

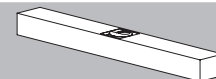

| | | | |
|------------------|----------------|--|--|
| Universal | | COMPLETE BOX KIT / KIT COMPLETO IN SCATOLA | |
| F | Bundle / Fasci | | |
| | | 0426 | Universal + Evolution (Track / Binario) |
| | | 0427 | Universal + Eclettica (Track / Binario) |
| | | 5 | W – Wall / Parete |
| | | 6 | C-W – Wall-Ceiling / Parete-Soffitto |
| | | 7 | C – Ceiling / Soffitto |
| | | 8 | C2 – Ceiling (Double) / Soffitto (Doppio) |
| | | 1 | L = 2000 mm |
| | | 2 | L = 2400 mm |
| | | 3 | L = 3000 mm |
| | | 02 | Brushed Anodized Silver / Argento Spazzolato |
| | | 13 | Brushed Anodized Dark Brown / E3 Spazzolato |
| | | 15 | Brushed Anodized Black / Nero Spazzolato |
| | | 17 | Brushed Anodized Nickel / Nichel Spazzolato |
| | | 25 | Brushed Anodized Graphite / Grafite Spazzolato |

| | | | |
|---------------------------|---|--|--|
| Universal Optional | | COMPLETE BOX KIT / KIT COMPLETO IN SCATOLA | |
| C.0420 | Complete handle kit / Kit completo maniglia | | |
| B.0425 | Complete load-bearing crosstrack kit / Kit completo traverso portante | | |
| B.0428 | Complete adjustable closing jamb kit / Kit completo battuta laterale regolabile | | |
| | | A | Accessories / Accessori |
| | | 0 | 120 mm |
| | | 1 | 1000 mm |
| | | 2 | 1200 mm |
| | | 3 | 1500 mm |
| | | 4 | 2200 mm |
| | | 5 | 2600 mm |
| | | 6 | 3000 mm |
| | | 02 | Brushed Anodized Silver / Argento Spazzolato |
| | | 13 | Brushed Anodized Dark Brown / E3 Spazzolato |
| | | 15 | Brushed Anodized Black / Nero Spazzolato |
| | | 17 | Brushed Anodized Nickel / Nichel Spazzolato |
| | | 25 | Brushed Anodized Graphite / Grafite Spazzolato |

EXAMPLE / ESEMPIO

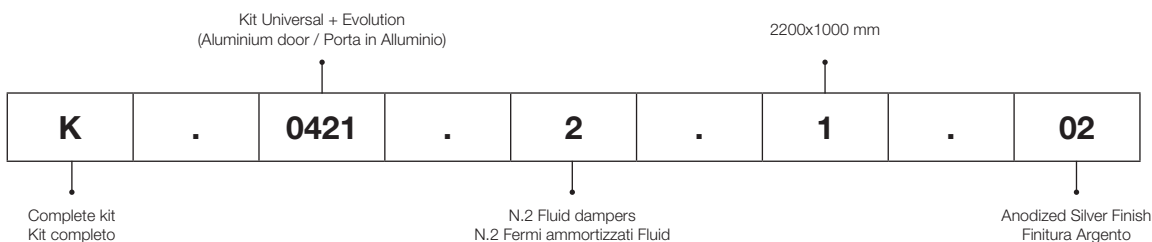

Universal

The new frame for aluminium, glass and wooden doors
Il nuovo telaio per ante in alluminio, vetro e legno

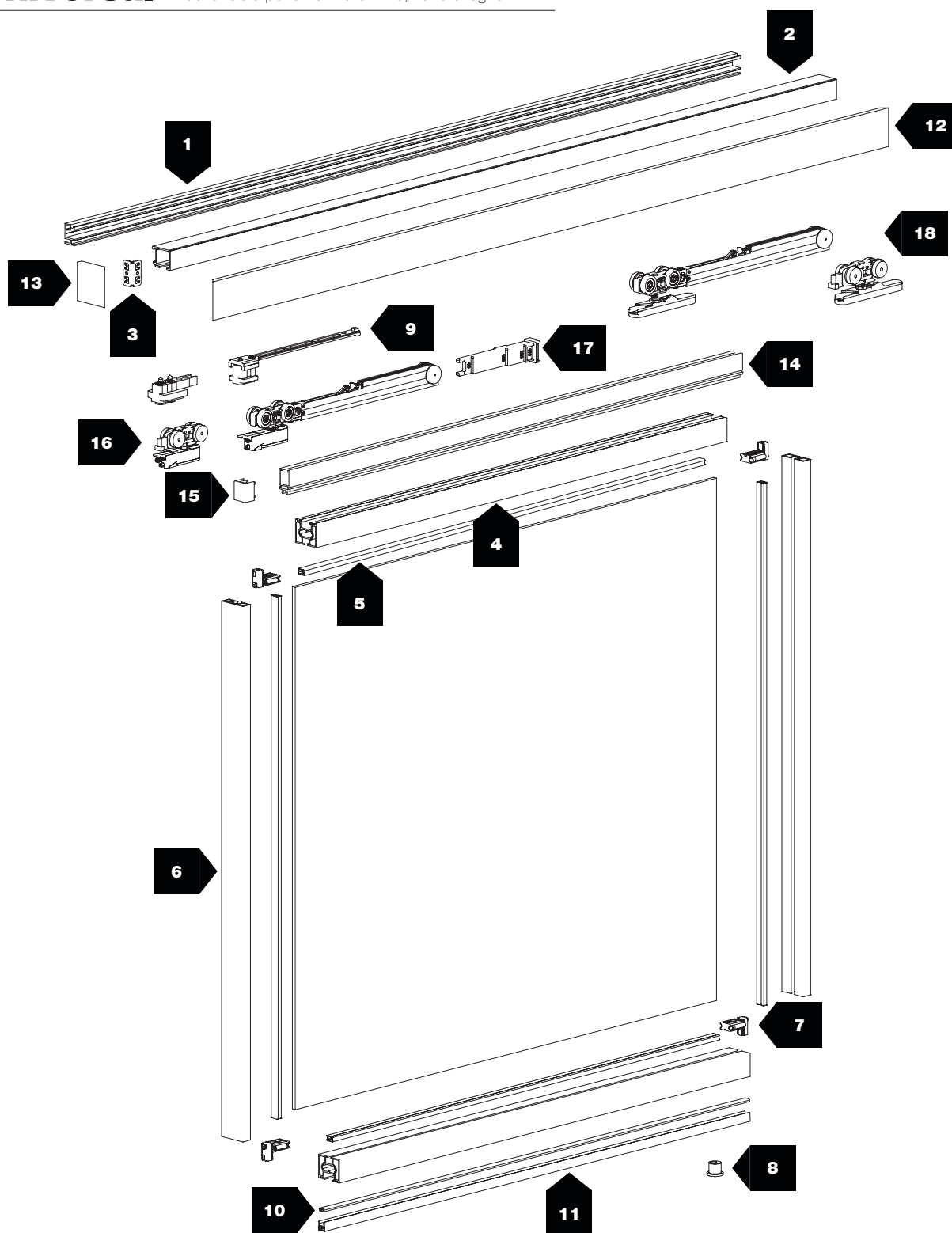

770 mm ÷ 1500 mm



Max 3000 mm



Max 80 kg

COLORS / COLORI



Brushed Anodized Silver
Argento Spazzolato



Brushed Anodized Nickel
Nichel Spazzolato



Brushed Anodized Graphite
Grafite Spazzolato



Brushed Anodized Dark Brown
E3 Spazzolato



Brushed Anodized Black
Nero Spazzolato

| N° | Barcode | Image | kg | |
|------------------|------------|-------|----|---------------------------|
| 1 | 1710 | | - | |
| 2 | 1700 | | - | |
| | 1280 | | - | |
| | 1560 | | - | |
| 3 | 2756 | | - | |
| 4 | 2762 | | - | |
| 5 | 2766 | | - | |
| 6 | 2761 | | - | |
| 7 | 2765 | | - | |
| 8 | 1577 | | - | |
| 9 | 3354 | | - | FLUD NEW |
| | 3347 | | - | |
| | 84 | | - | |
| 10 | 266 | | - | |
| 11 | 1738 | | - | |
| EVOLUTION | | | | |
| 12 | 2764 | | - | |
| 13 | 2764/2 | | - | |
| 14 | 2763 | | - | |
| | 2753 | | - | |
| 15 | 2767 | | - | |
| 16 | 3362-80 | | 80 | FLUD NEW |
| | 2363/T | | 80 | |
| 17 | 2353 | | - | |
| ECLETTICA | | | | |
| 12 | 2755 | | - | |
| 13 | 2755/2 | | - | |
| 18 | 3382-80_DX | | 80 | FLUD NEW |
| | 3382-80_SX | | 80 | |
| | 83/T | | 80 | |

EVOLUTION

COMPLETE KIT (FOR ONE SLIDING ALUMINIUM DOOR)
KIT COMPLETO (PER UNA PORTA SCORREVOLE IN ALLUMINIO)

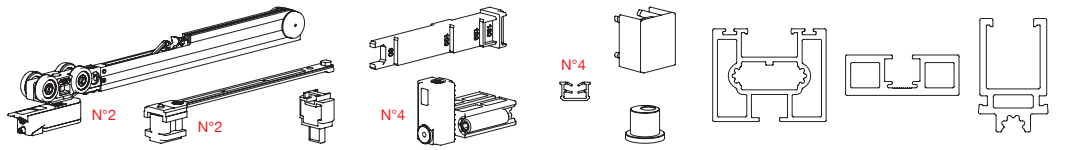
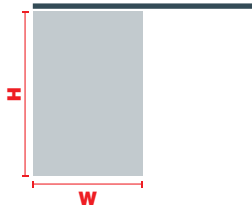

| W | H | | | CODE | COLOURS / COLORI | | | | | |
|---------|---------|-----------|-------|------------|------------------|-----|------|-----|-----|----|
| | | | | | AS | NKS | GRFS | E3S | NS | |
| 1000 mm | 2200 mm | EVOLUTION | 80 kg | K.0421.2.1 | .02 | .17 | .25 | .13 | .15 | 1x |
| 1200 mm | 2600 mm | | | K.0421.2.2 | .02 | .17 | .25 | .13 | .15 | 1x |
| 1500 mm | 3000 mm | | | K.0421.2.3 | .02 | .17 | .25 | .13 | .15 | 1x |

EVOLUTION

COMPLETE KIT (FOR ONE FIX ALUMINIUM DOOR)
KIT COMPLETO (PER UNA PORTA FISSA IN ALLUMINIO)

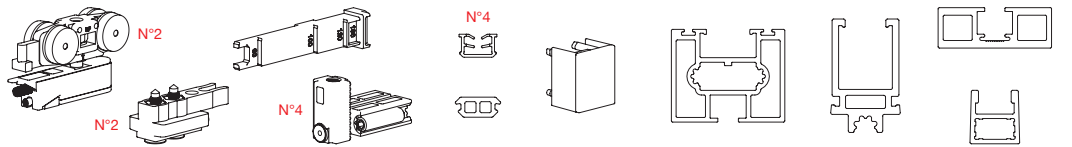
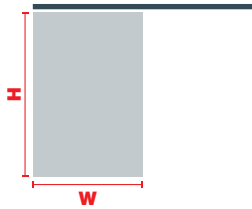

| W | H | | | CODE | COLOURS / COLORI | | | | | |
|---------|---------|-----------|-------|------------|------------------|-----|------|-----|-----|----|
| | | | | | AS | NKS | GRFS | E3S | NS | |
| 1000 mm | 2200 mm | EVOLUTION | 80 kg | K.0422.0.1 | .02 | .17 | .25 | .13 | .15 | 1x |
| 1200 mm | 2600 mm | | | K.0422.0.2 | .02 | .17 | .25 | .13 | .15 | 1x |
| 1500 mm | 3000 mm | | | K.0422.0.3 | .02 | .17 | .25 | .13 | .15 | 1x |

EVOLUTION

COMPLETE KIT (FOR ONE SLIDING WOODEN DOOR)
KIT COMPLETO (PER UNA PORTA SCORREVOLE IN LEGNO)

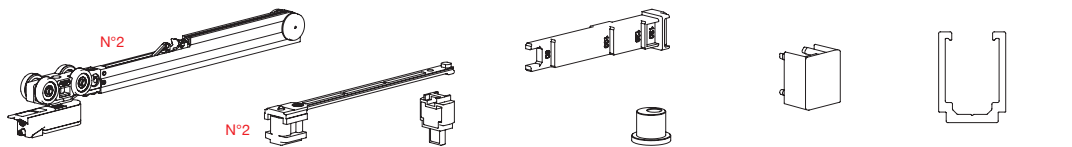
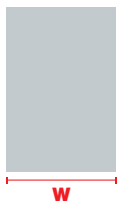

| W | | | CODE | COLOURS / COLORI | | | | | |
|---------|-----------|-------|------------|------------------|-----|------|-----|-----|----|
| | | | | AS | NKS | GRFS | E3S | NS | |
| 1000 mm | EVOLUTION | 80 kg | K.0425.2.4 | .02 | .17 | .25 | .13 | .15 | 1x |
| 1200 mm | | | K.0425.2.5 | .02 | .17 | .25 | .13 | .15 | 1x |
| 1500 mm | | | K.0425.2.6 | .02 | .17 | .25 | .13 | .15 | 1x |

EVOLUTION

COMPLETE KIT (FOR ONE FIX WOODEN DOOR)
KIT COMPLETO (PER UNA PORTA IN LEGNO FISSA)

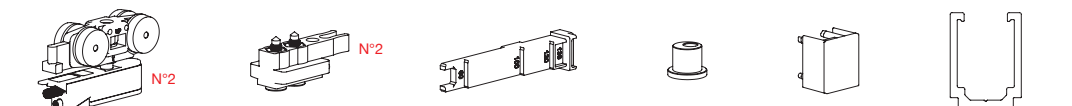
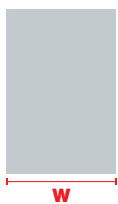

| W | | | CODE | COLOURS / COLORI | | | | | |
|---------|-----------|-------|------------|------------------|-----|------|-----|-----|----|
| | | | | AS | NKS | GRFS | E3S | NS | |
| 1000 mm | EVOLUTION | 80 kg | K.0426.0.4 | .02 | .17 | .25 | .13 | .15 | 1x |
| 1200 mm | | | K.0426.0.5 | .02 | .17 | .25 | .13 | .15 | 1x |
| 1500 mm | | | K.0426.0.6 | .02 | .17 | .25 | .13 | .15 | 1x |

TRACKS BY TYPE OF PLACEMENT
BINARI PER TIPOLOGIA DI INSTALLAZIONE

EVOLUTION

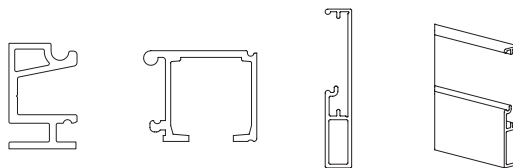

| L | PLACEMENT / INSTALLAZIONE | CODE | COLOURS / COLORI | | | | | MIN |
|---------|---------------------------|------------|------------------|-----|------|-----|-----|-----|
| | | | AS | NKS | GRFS | E3S | NS | |
| 2000 mm | WALL / PARETE | F.0426.5.1 | .02 | .17 | .25 | .13 | .15 | 1x |
| 2400 mm | | F.0426.5.2 | .02 | .17 | .25 | .13 | .15 | 1x |
| 3000 mm | | F.0426.5.3 | .02 | .17 | .25 | .13 | .15 | 1x |

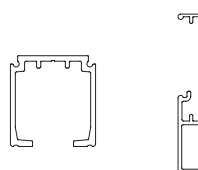

| L | PLACEMENT / INSTALLAZIONE | CODE | COLOURS / COLORI | | | | | MIN |
|---------|------------------------------------|------------|------------------|-----|------|-----|-----|-----|
| | | | AS | NKS | GRFS | E3S | NS | |
| 2000 mm | WALL & CEILING / PARETE E SOFFITTO | F.0426.6.1 | .02 | .17 | .25 | .13 | .15 | 1x |
| 2400 mm | | F.0426.6.2 | .02 | .17 | .25 | .13 | .15 | 1x |
| 3000 mm | | F.0426.6.3 | .02 | .17 | .25 | .13 | .15 | 1x |

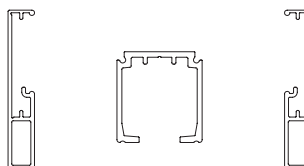

| L | PLACEMENT / INSTALLAZIONE | CODE | COLOURS / COLORI | | | | | MIN |
|---------|---------------------------|------------|------------------|-----|------|-----|-----|-----|
| | | | AS | NKS | GRFS | E3S | NS | |
| 2000 mm | CEILING / SOFFITTO | F.0426.7.1 | .02 | .17 | .25 | .13 | .15 | 1x |
| 2400 mm | | F.0426.7.2 | .02 | .17 | .25 | .13 | .15 | 1x |
| 3000 mm | | F.0426.7.3 | .02 | .17 | .25 | .13 | .15 | 1x |

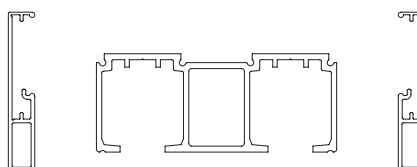

| L | PLACEMENT / INSTALLAZIONE | CODE | COLOURS / COLORI | | | | | MIN |
|---------|---------------------------|------------|------------------|-----|------|-----|-----|-----|
| | | | AS | NKS | GRFS | E3S | NS | |
| 2000 mm | CEILING / SOFFITTO | F.0426.8.1 | .02 | .17 | .25 | .13 | .15 | 1x |
| 2400 mm | | F.0426.8.2 | .02 | .17 | .25 | .13 | .15 | 1x |
| 3000 mm | | F.0426.8.3 | .02 | .17 | .25 | .13 | .15 | 1x |

ECLETTICA

COMPLETE KIT (FOR ONE SLIDING ALUMINIUM DOOR)
KIT COMPLETO (PER UNA PORTA SCORREVOLE IN ALLUMINIO)

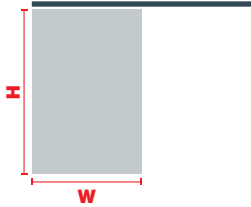
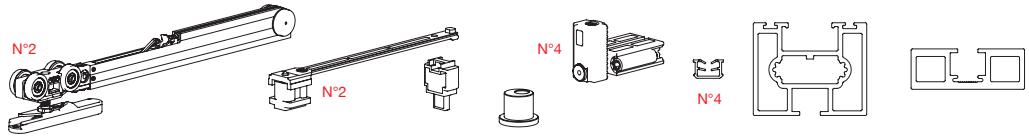
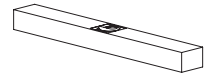

| W | H | EYES | PERSON | CODE | COLOURS / COLORI | | | | | MIN |
|---------|---------|-----------|--------|------------|------------------|-----|------|-----|-----|-----|
| | | | | | AS | NKS | GRFS | E3S | NS | |
| 1000 mm | 2200 mm | ECLETTICA | 80 kg | K.0423.1.1 | .02 | .17 | .25 | .13 | .15 | 1x |
| 1200 mm | 2600 mm | | | K.0423.1.2 | .02 | .17 | .25 | .13 | .15 | 1x |
| 1500 mm | 3000 mm | | | K.0423.1.3 | .02 | .17 | .25 | .13 | .15 | 1x |

ECLETTICA

COMPLETE KIT (FOR ONE FIX ALUMINIUM DOOR)
KIT COMPLETO (PER UNA PORTA FISSA IN ALLUMINIO)

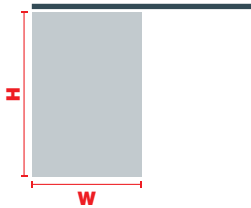
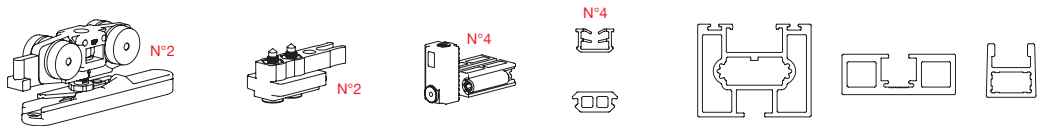
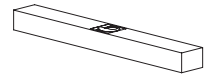

| W | H | EYES | PERSON | CODE | COLOURS / COLORI | | | | | MIN |
|---------|---------|-----------|--------|------------|------------------|-----|------|-----|-----|-----|
| | | | | | AS | NKS | GRFS | E3S | NS | |
| 1000 mm | 2200 mm | ECLETTICA | 80 kg | K.0424.0.1 | .02 | .17 | .25 | .13 | .15 | 1x |
| 1200 mm | 2600 mm | | | K.0424.0.2 | .02 | .17 | .25 | .13 | .15 | 1x |
| 1500 mm | 3000 mm | | | K.0424.0.3 | .02 | .17 | .25 | .13 | .15 | 1x |

ECLETTICA

COMPLETE KIT (FOR ONE SLIDING WOODEN DOOR)
KIT COMPLETO (PER UNA PORTA IN LEGNO SCORREVOLE)

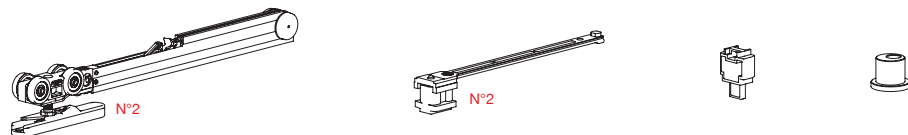

| EYES | PERSON | CODE | MIN |
|-----------|--------|------------|-----|
| ECLETTICA | 80 kg | K.0427.1.0 | 1x |

ECLETTICA

COMPLETE KIT (FOR ONE FIX WOODEN DOOR)
KIT COMPLETO (PER UNA PORTA IN LEGNO FISSA)

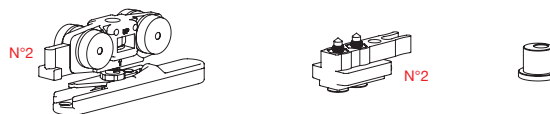

| EYES | PERSON | CODE | MIN |
|-----------|--------|------------|-----|
| ECLETTICA | 80 kg | K.0428.0.0 | 1x |

TRACKS BY TYPE OF PLACEMENT
BINARI PER TIPOLOGIA DI INSTALLAZIONE

ECCLETTICA

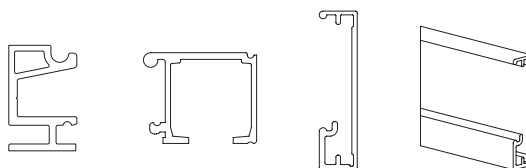

| L | PLACEMENT / INSTALLAZIONE | CODE | COLOURS / COLORI | | | | | MIN |
|---------|---------------------------|------------|------------------|-----|------|-----|-----|-----|
| | | | AS | NKS | GRFS | E3S | NS | |
| 2000 mm | WALL / PARETE | F.0427.5.1 | .02 | .17 | .25 | .13 | .15 | 1x |
| 2400 mm | | F.0427.5.2 | .02 | .17 | .25 | .13 | .15 | 1x |
| 3000 mm | | F.0427.5.3 | .02 | .17 | .25 | .13 | .15 | 1x |

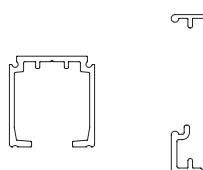

| L | PLACEMENT / INSTALLAZIONE | CODE | COLOURS / COLORI | | | | | MIN |
|---------|------------------------------------|------------|------------------|-----|------|-----|-----|-----|
| | | | AS | NKS | GRFS | E3S | NS | |
| 2000 mm | WALL & CEILING / PARETE E SOFFITTO | F.0427.6.1 | .02 | .17 | .25 | .13 | .15 | 1x |
| 2400 mm | | F.0427.6.2 | .02 | .17 | .25 | .13 | .15 | 1x |
| 3000 mm | | F.0427.6.3 | .02 | .17 | .25 | .13 | .15 | 1x |

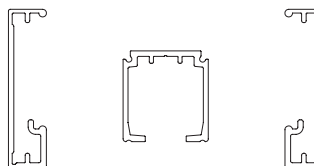

| L | PLACEMENT / INSTALLAZIONE | CODE | COLOURS / COLORI | | | | | MIN |
|---------|---------------------------|------------|------------------|-----|------|-----|-----|-----|
| | | | AS | NKS | GRFS | E3S | NS | |
| 2000 mm | CEILING / SOFFITTO | F.0427.7.1 | .02 | .17 | .25 | .13 | .15 | 1x |
| 2400 mm | | F.0427.7.2 | .02 | .17 | .25 | .13 | .15 | 1x |
| 3000 mm | | F.0427.7.3 | .02 | .17 | .25 | .13 | .15 | 1x |

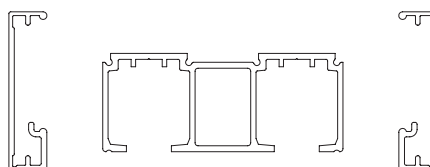

| L | PLACEMENT / INSTALLAZIONE | CODE | COLOURS / COLORI | | | | | MIN |
|---------|---------------------------|------------|------------------|-----|------|-----|-----|-----|
| | | | AS | NKS | GRFS | E3S | NS | |
| 2000 mm | CEILING / SOFFITTO | F.0427.8.1 | .02 | .17 | .25 | .13 | .15 | 1x |
| 2400 mm | | F.0427.8.2 | .02 | .17 | .25 | .13 | .15 | 1x |
| 3000 mm | | F.0427.8.3 | .02 | .17 | .25 | .13 | .15 | 1x |

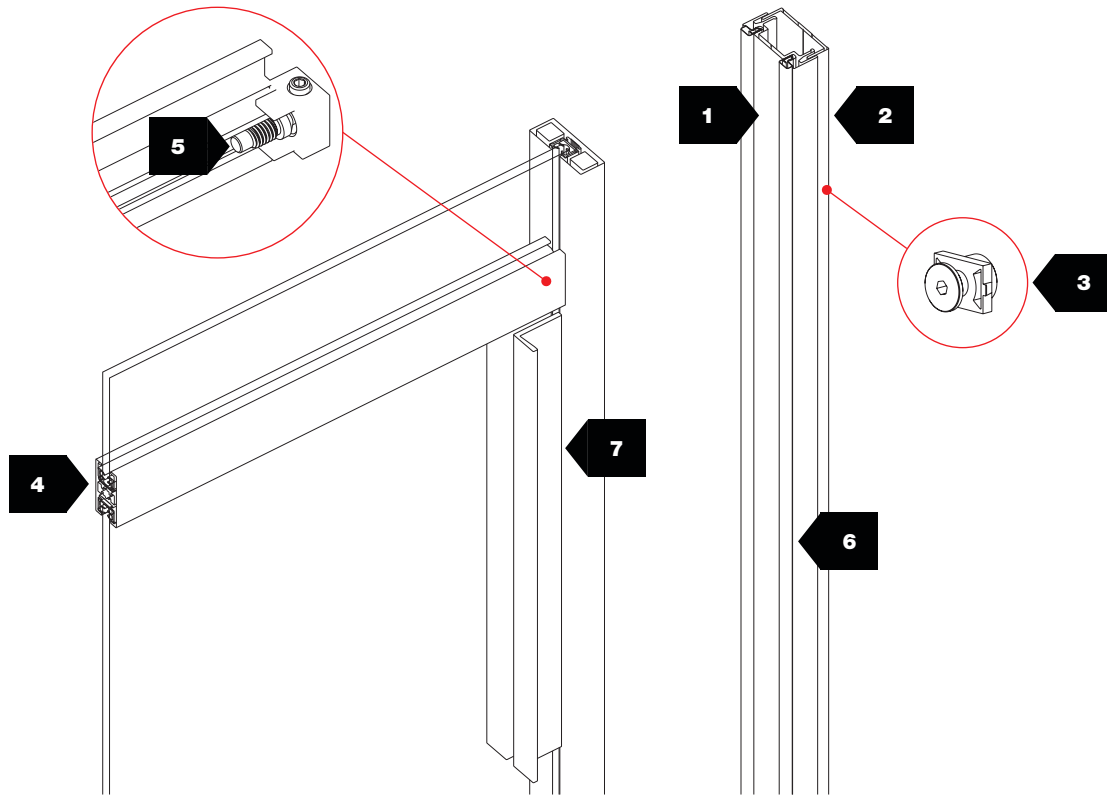

ADJUSTABLE CLOSING JAMB
BATTUTA LATERALE REGOLABILE

CROSSTRACK
TRAVERSO

HANDLE
MANIGLIA

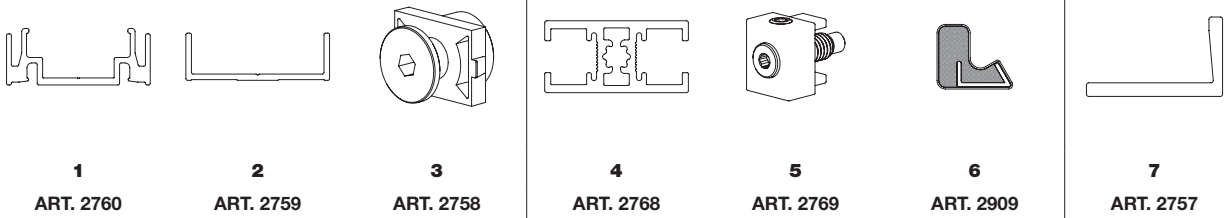

1
ART. 2760

2
ART. 2759

3
ART. 2758

4
ART. 2768

5
ART. 2769

6
ART. 2909

7
ART. 2757

COMPLETE KIT (FOR DOOR HANDLE)
KIT COMPLETO (PER MANIGLIA)

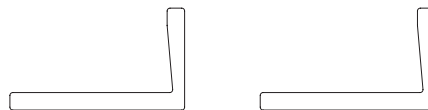

| CODE | COLOURS / COLORI | | | | | MIN |
|---------------------------------|----------------------------------|----------------------------------|----------------------------------|----------------------------------|----------------------------------|-----|
| | AS | NKS | GRFS | E3S | NS | |
| C.0420.A.0 <input type="text"/> | <input type="text" value=".02"/> | <input type="text" value=".17"/> | <input type="text" value=".25"/> | <input type="text" value=".13"/> | <input type="text" value=".15"/> | - |

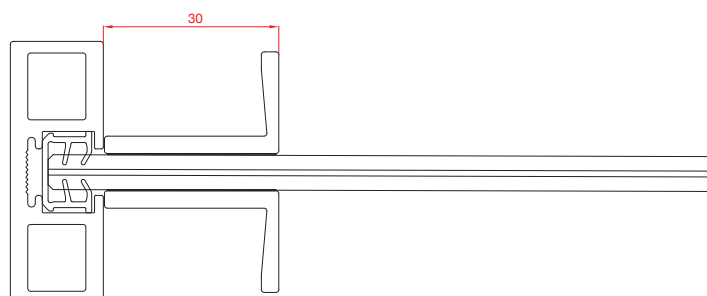

COMPLETE KIT (FOR LOAD-BEARING CROSSTRACKS)
KIT COMPLETO (PER UN TRAVERSO PORTANTE)

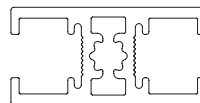
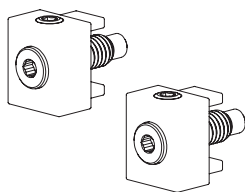

| W | | CODE | COLOURS / COLORI | | | | | |
|---------|--------------|------------|------------------|-----|------|-----|-----|---|
| | | | AS | NKS | GRFS | E3S | NS | |
| 1000 mm | 80 kg | B.0425.A.1 | .02 | .17 | .25 | .13 | .15 | — |
| 1200 mm | | B.0425.A.2 | .02 | .17 | .25 | .13 | .15 | — |
| 1500 mm | | B.0425.A.3 | .02 | .17 | .25 | .13 | .15 | — |

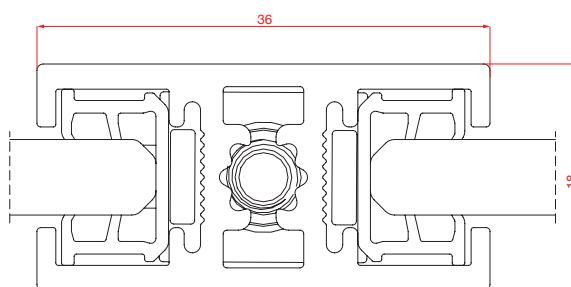

COMPLETE KIT (FOR ONE ADJUSTABLE CLOSING JAMB)
KIT COMPLETO (PER UNA BATTUTA LATERALE REGOLABILE)

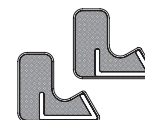
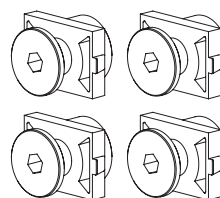
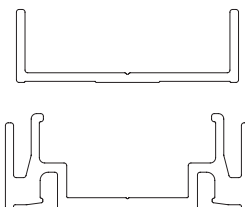

| H | | CODE | COLOURS / COLORI | | | | | |
|---------|--------------|------------|------------------|-----|------|-----|-----|---|
| | | | AS | NKS | GRFS | E3S | NS | |
| 2200 mm | 80 kg | B.0428.A.4 | .02 | .17 | .25 | .13 | .15 | — |
| 2600 mm | | B.0428.A.5 | .02 | .17 | .25 | .13 | .15 | — |
| 3000 mm | | B.0428.A.6 | .02 | .17 | .25 | .13 | .15 | — |

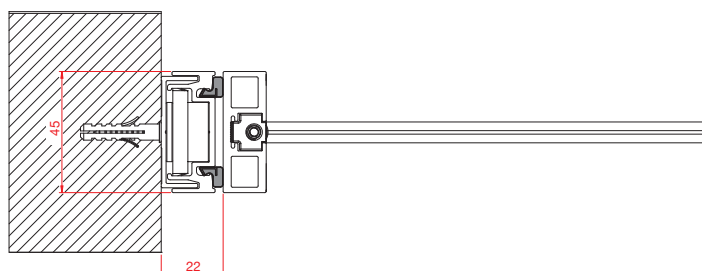

GLASS SIZE CALCULATION TABLE / CALCOLO VETRO

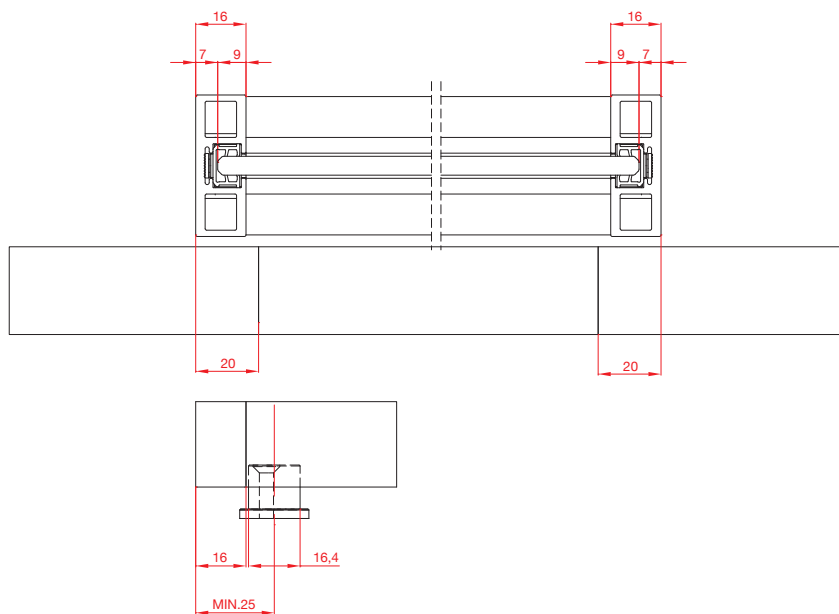
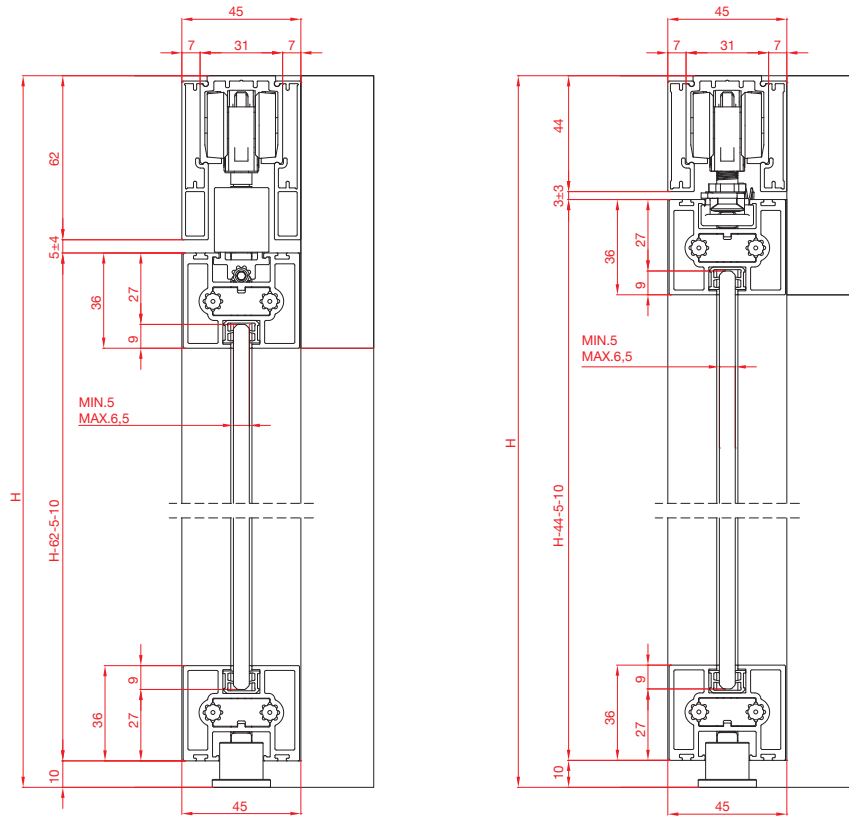



Vetro 24

Accessories for glass doors with drillings and clamp height 24 mm
Accessori per porte in vetro con forature e pinza alta 24 mm





Vetro 24

Sliding system for glass doors with clamp height 24 mm
Scorrevoli per porte in vetro con pinza alta 24 mm

Vetro 24 is a sliding system suitable for **glass doors with drilling requirements and double clamps at reduced height** (only 24 mm).

This system match both with **monolithic and laminated glass**, with thicknesses from 8-8,7 mm (5/16") and 10-10,7 mm (3/8").

Vetro 24 integrates the new sliding trolleys, with **Fluid technology**: the movement turns out to be extremely soft, in opening and closing, for a costantly improved user experience.

The **Vetro 24** system is very **versatile**: it can also be used with counter frames.

Vetro 24 è il sistema scorrevole per porte in **vetro forato con doppia pinza ad altezza ridotta** (solo 24 mm).

Il sistema è **compatibile** con **vetri monolitici o stratificati**, con spessori da 8-8,7 (5/16") mm e 10-10,7 mm (3/8").

Vetro 24 integra i nuovi scorrevoli, con tecnologia **Fluid**: il movimento risulta così estremamente morbido, in apertura e in chiusura, per una esperienza ancora migliore.







Il sistema **Vetro 24** è molto **versatile**: si può utilizzare, infatti, anche con controtelai.





Vetro 24

COMPLETE BOX KIT / KIT COMPLETO IN SCATOLA

| | | | |
|----------|--|---|--|
| K | Complete kit for glass doors with clamp height 24 mm / Kit completo per porte in vetro con pinza 24 mm | | |
| | | | |
| | 0311 |  For glass - Thickness 8-8,7 mm (5/16") Per vetro - Spessore 8-8,7 mm (5/16") | |
| | 0312 |  For glass - Thickness 10-10,7 mm (3/8") Per vetro - Spessore 10-10,7 mm (3/8") | |
| | 0313 |  For glass - Thickness 8-8,7 mm (5/16") - Cover ART.1725 Per vetro - Spessore 8-8,7 mm (5/16") - Copertura ART.1725 | |
| | 0314 |  For glass - Thickness 10-10,7 mm (3/8") - Cover ART.1725 Per vetro - Spessore 10-10,7 mm (3/8") - Copertura ART.1725 | |
| | 0315 |  For glass - Thickness 8-8,7 mm (5/16") - Cover ART.1742 Per vetro - Spessore 8-8,7 mm (5/16") - Copertura ART.1742 | |
| | 0316 |  For glass - Thickness 10-10,7 mm (3/8") - Cover ART.1742 Per vetro - Spessore 10-10,7 mm (3/8") - Copertura ART.1742 | |
| | | | |
| | | | 0 Only spacers Solo distanziali (traduzione) |
| | | | 5 N.1 Fluid damper + N.1 Shock absorber N.1 Fermo Fluid + N.1 Fermo a pinza ammortizzato |
| | | | 6 N.2 Fluid dampers N.2 Fermi ammortizzati Fluid |
| | | | 7 N.2 Shock absorber N.2 Fermi a pinza ammortizzati |
| | | | |
| | | | 01 Anodized Silver / Argento |

Vetro 24

COMPLETE BOX BLISTER / BLISTER COMPLETO IN SCATOLA

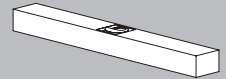

| | | | |
|----------|-------------------------------------|---|-------------------------------------|
| B | Complete blister / Blister completo | | |
| | | | |
| | 0315 | Min. width 700 mm / Lunghezza Min. 700 mm | |
| | 0316 | Min. width 800 mm / Lunghezza Min. 800 mm | |
| | 0317 | Min. width 900 mm / Lunghezza Min. 900 mm | |
| | 0318 | Min. width 1000 mm / Lunghezza Min. 1000 mm | |
| | 0319 | Min. width 1200 mm / Lunghezza Min. 1200 mm | |
| | | | |
| | | | 8 Covers / Coperture |
| | | | |
| | | | 01 Anodized Silver / Argento |

EXAMPLE / ESEMPIO

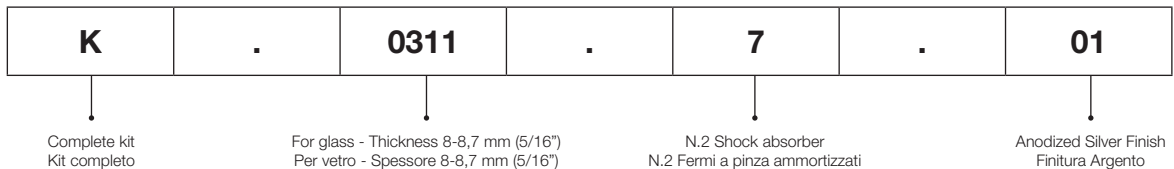

Tracks / Binari

ALUMINUM FINISHES CODES / CODICI FINITURE ALLUMINIO



| CODE / CODICE | FINISH COLOR / COLORE FINITURA | |
|-----------------------|--------------------------------|--|
| 8 00 0.0 | 00 G | Raw / Mill Finish / Neutro / Grezzo |
| 8 01 0.0 | 01 A | Anodized Silver / Argento |
| 8 02 0.0 | 02 AS | Brushed Anodized Silver / Argento Spazzolato |
| STANDARD | | |

Vetro 24

Sliding system for glass doors with clamp height 24 mm
Scorrevoli per porte in vetro con pinza alta 24 mm

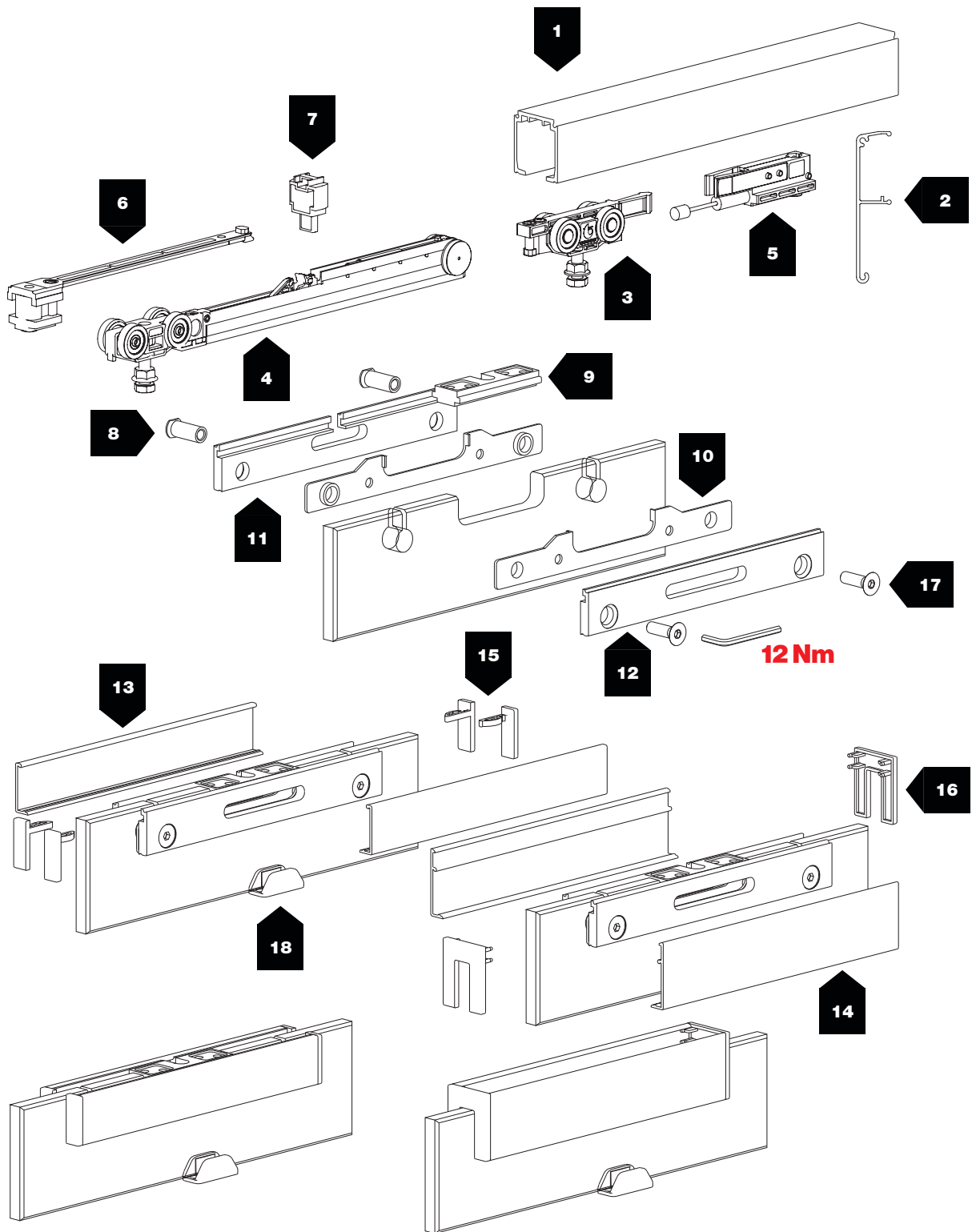







8-8,7 ÷ 10-10,7 mm



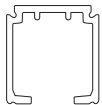
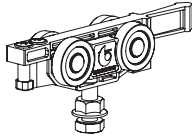
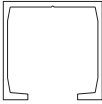
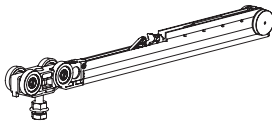
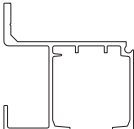
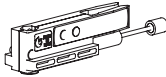

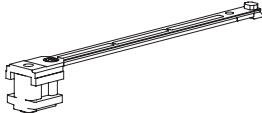





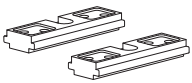

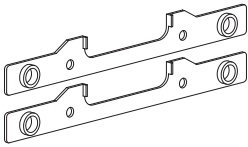
80 kg

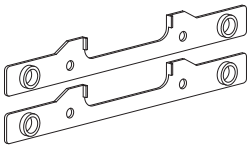
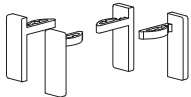
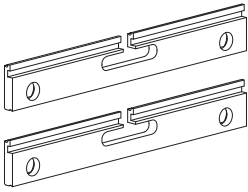
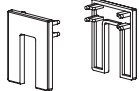

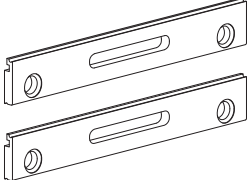
10 mm



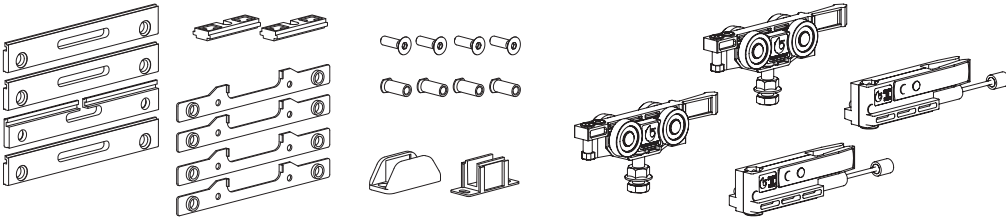

| N° | Barcode | | kg | | N° | Barcode | | kg | |
|----|----------------------|---|----|--|----|--------------|---|----|--------------|
| 1 | 1280 8 01 0.01280 |  | - | | 3 | 3358/V24 |  | 80 | FLUVD NEW |
| | 1080 8 01 0.01080 |  | - | | 4 | 3352/080/V24 |  | 80 | FLUVD NEW |
| | 1359 8 01 0.01359 |  | - | | 5 | 3355/080 |  | 80 | FLUVD NEW |
| | 1700 8 01 0.01700 |  | - | | 6 | 3354 |  | 80 | FLUVD NEW |
| | 1720 8 01 0.01720 |  | - | | 7 | 3347 |  | - | |
| 2 | 1380 8 02 0.01380 |  | - | | 8 | 1721 |  | - | |

| N° | | | kg | | N° | | | kg | |
|----|----------|---|----|--|----|----------------------|---|----|--|
| 9 | 1714 |  | - | | 14 | 1742 8 02 0.01742 |  | - | |
| 10 | 1723/8 |  | - | | 15 | 1722/8 |  | - | |
| | 1723/10 |  | - | | | 1722/10 |  | - | |
| 11 | 1724/B/A |  | - | | 16 | 1744 |  | - | |
| | | | | | 17 | M6x20 |  | - | |
| 12 | 1724/V/A |  | - | | 18 | 1486/8 |  | 80 | |
| 13 | 1725/A |  | - | | | 1486/10 |  | 80 | |







-  N.2 Shock absorbers
N.2 Fermi a pinza ammortizzati
-  Ball bearings
Cuscinetti a sfera
-  Anodized Silver
Argento

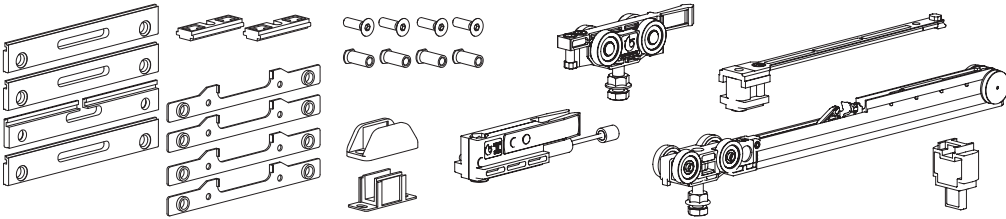



FLUID

|  | OLD CODE | NEW CODE |  |  |  |  |
|---|----------|-------------|---|---|---|---|
| KIT | - | K.0311.7.01 | 80 kg | Min. 600 mm | 8-8,7 mm (5/16") | 5x |
| | - | K.0312.7.01 | | | 10-10,7 mm (3/8") | 5x |



-  N.1 Fluid damper
N.1 Fermo ammortizzato
FLUID
-  N.1 Shock absorber
N.1 Fermo a pinza ammortizzato
-  Ball bearings
Cuscinetti a sfera
-  Anodized Silver
Argento



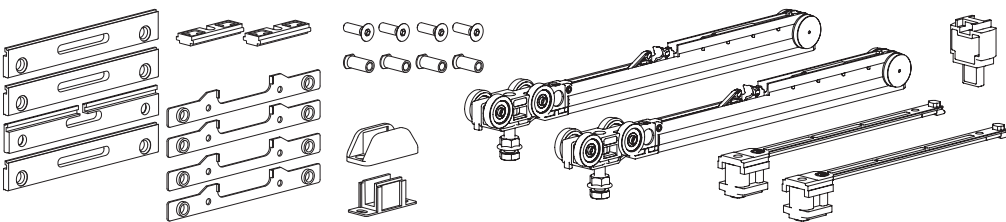

FLUID

|  | OLD CODE | NEW CODE |  |  |  |  |
|---|----------|-------------|---|---|---|---|
| KIT | - | K.0311.5.01 | 80 kg | Min. 650 mm | 8-8,7 mm (5/16") | 4x |
| | - | K.0312.5.01 | | | 10-10,7 mm (3/8") | 4x |



-  N.2 Fluid dampers
N.2 Fermi ammortizzati
FLUID
-  Ball bearings
Cuscinetti a sfera
-  Anodized Silver
Argento

FLUID

|  | OLD CODE | NEW CODE |  |  |  |  |
|---|----------|-------------|---|---|---|---|
| KIT | - | K.0311.6.01 | 80 kg | Min. 860 mm | 8-8,7 mm (5/16") | 4x |
| | - | K.0312.6.01 | | | 10-10,7 mm (3/8") | 4x |

LOWER GUIDES / GUIDE INFERIORI

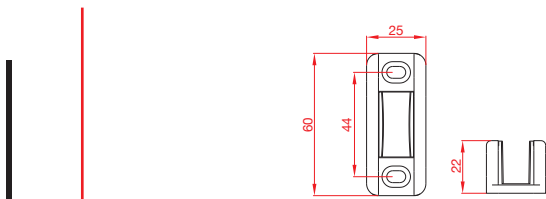

STANDARD

ART. 1486/8 (8-8,7 mm - 5/16") ART. 1486/10 (10-10,7 mm - 3/8")

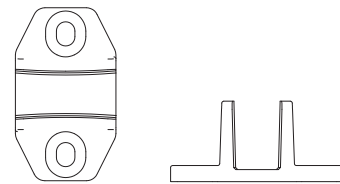

COUNTERFRAMES / CONTROTELAI

ART. 118 (8-8,7 mm - 5/16") ART. 110 (10-10,7 mm - 3/8")

TOPS & COVERS / TAPPI E COPERTURE

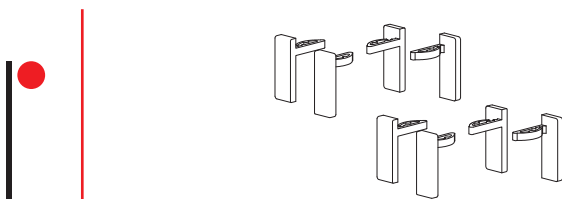

OPTIONAL

ART. 1722/8 ART. 1744

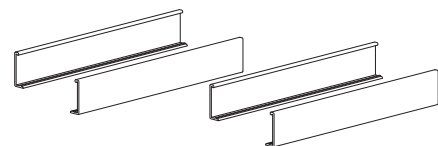

OPTIONAL

ART. 1725/170 ART. 1742

MEASUREMENTS DESCRIPTION / DESCRIZIONI MISURE

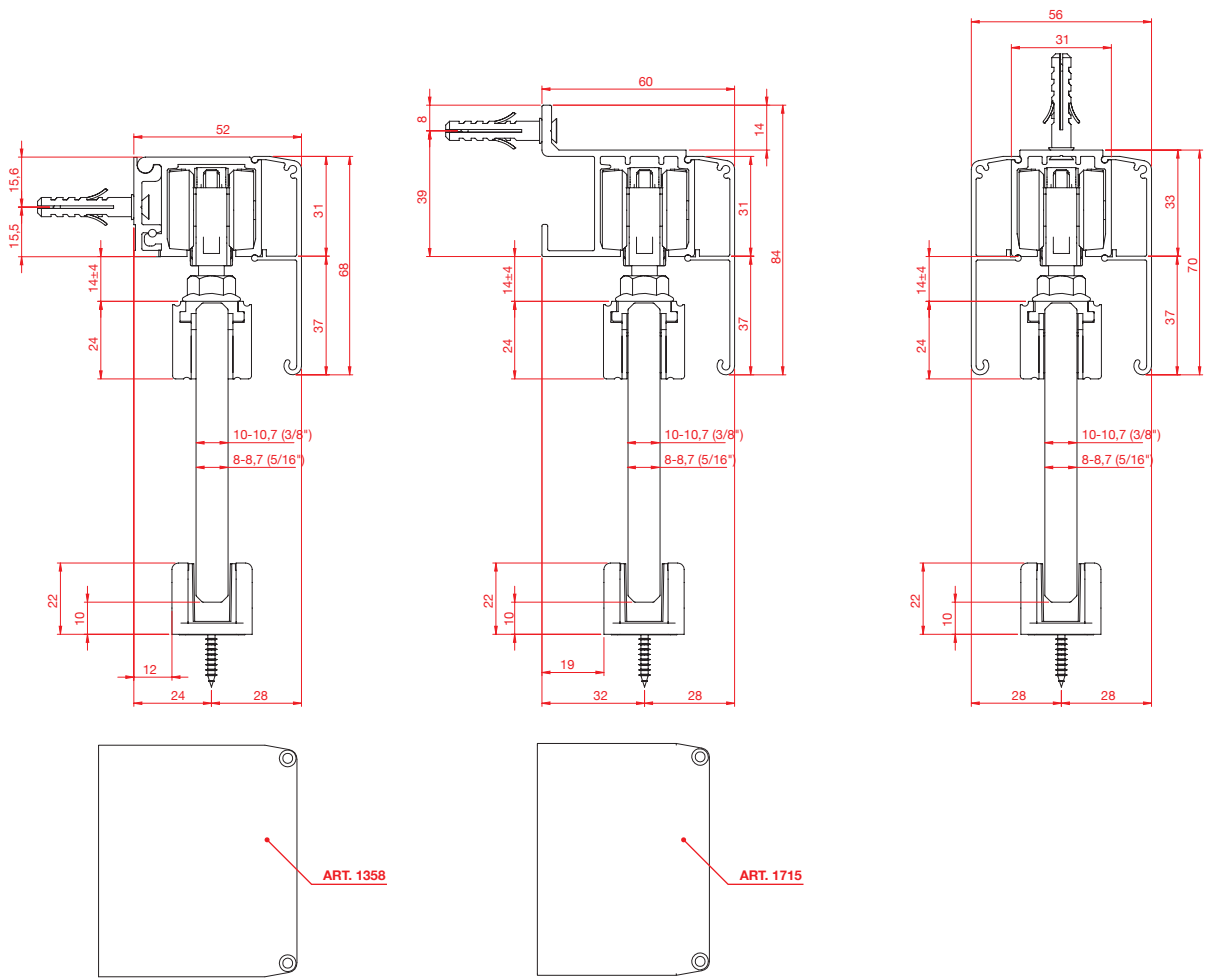

CLAMP COVER MEASUREMENTS DESCRIPTION / DESCRIZIONI MISURE COPERTURE PINZE

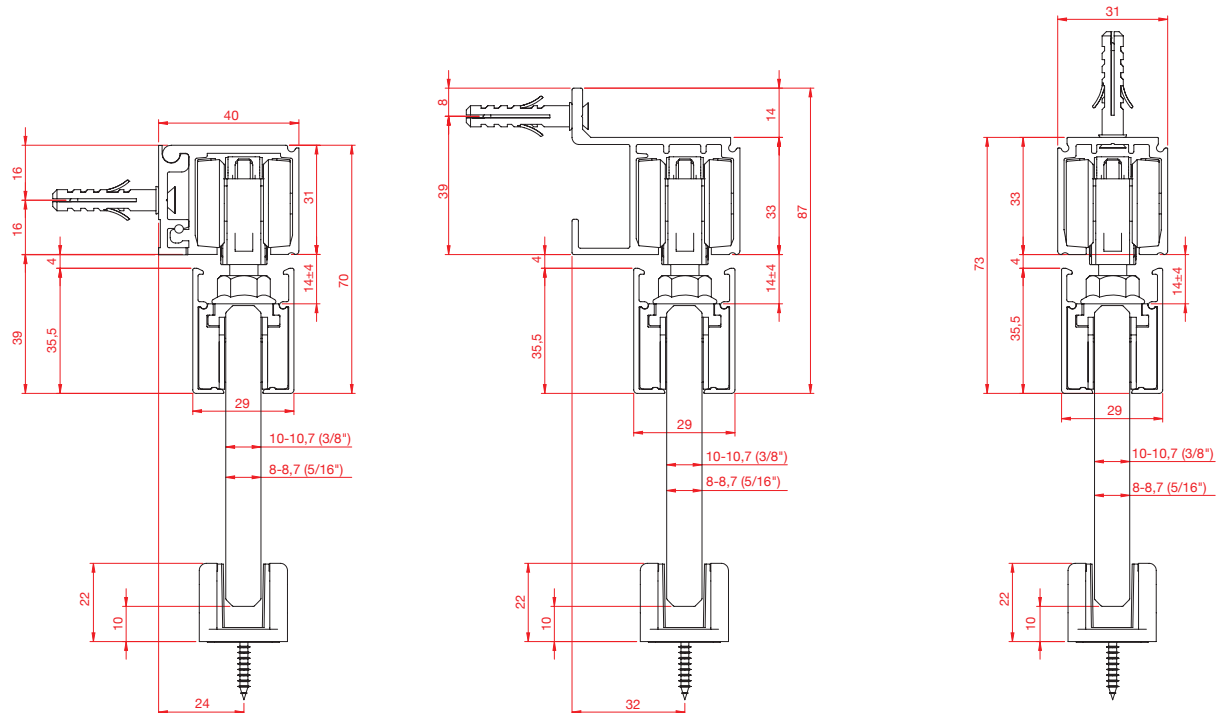

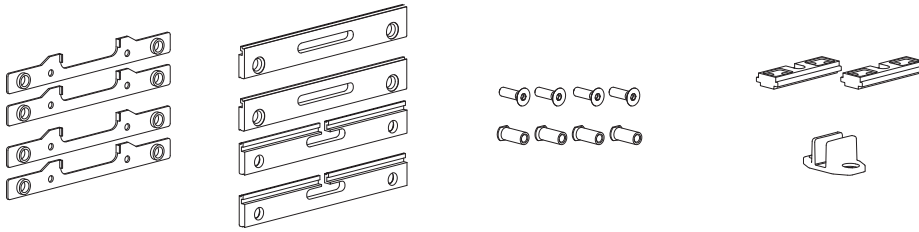

Counterframes kit
 Kit per controtelai

.01 Anodized Silver
 Argento

| OLD CODE | NEW CODE | 80 kg | 8-8,7 mm (5/16") | 5x |
|----------------|-------------|-------|-------------------|----|
| 1724/1723/8/A | K.0311.0.01 | | 10-10,7 mm (3/8") | 5x |
| 1724/1723/10/A | K.0312.0.01 | | | |

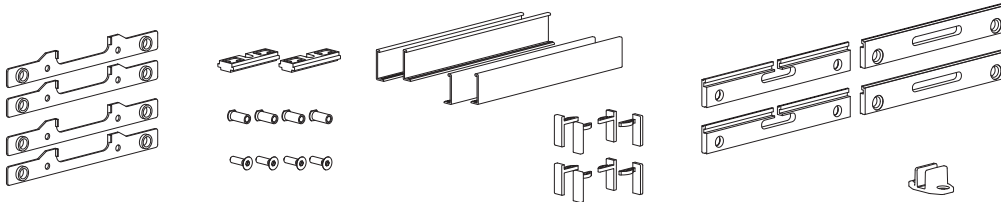

Counterframes kit
 Kit per controtelai

.01 Anodized Silver
 Argento

| OLD CODE | NEW CODE | 80 kg | 8-8,7 mm (5/16") | 5x |
|----------------|-------------|-------|-------------------|----|
| 1724/1725/8/A | K.0313.0.01 | | 10-10,7 mm (3/8") | 5x |
| 1724/1725/10/A | K.0314.0.01 | | | |

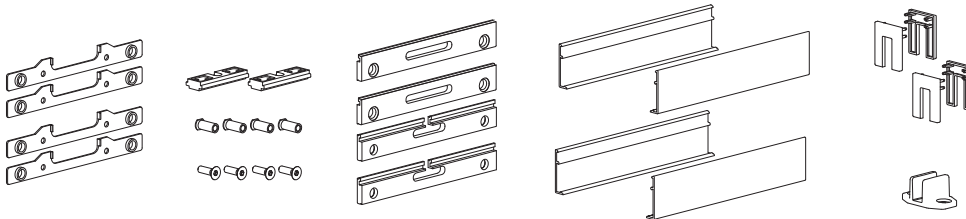

Counterframes kit
 Kit per controtelai

.01 Anodized Silver
 Argento

| OLD CODE | NEW CODE | 80 kg | 8-8,7 mm (5/16") | 5x |
|----------------|-------------|-------|-------------------|----|
| 1724/1742/8/A | K.0315.0.01 | | 10-10,7 mm (3/8") | 5x |
| 1724/1742/10/A | K.0316.0.01 | | | |

MEASUREMENTS DESCRIPTION / DESCRIZIONI MISURE

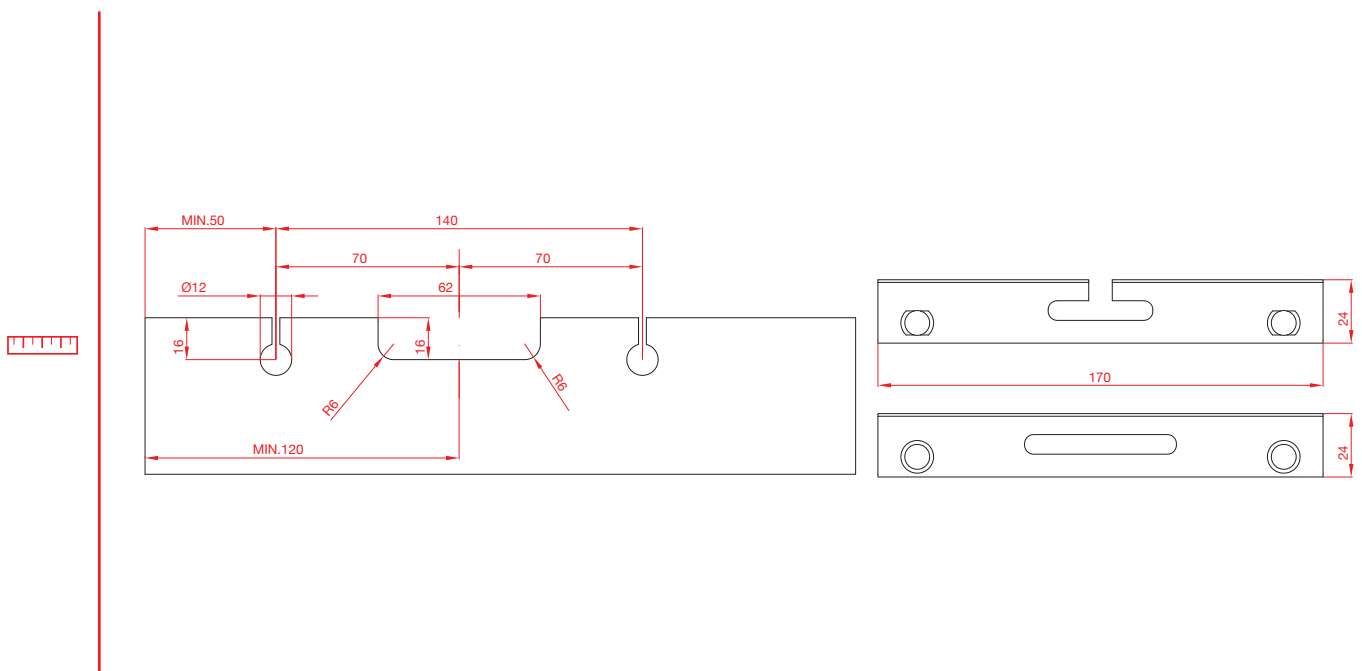

Vetro 24

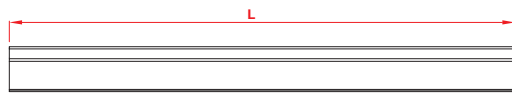

Sliding system for glass doors with clamp height 24 mm
Scorrevoli per porte in vetro con pinza alta 24 mm



ART. 1742
(8010.01742)



ART. 1744

|  | OLD CODE | NEW CODE | L | |  |
|---|------------|-------------|-------------|-------------|---|
| BLISTER | 1742/70/A | B.0315.8.01 | Min.700 mm | Max.799 mm | 5x |
| | 1742/80/A | B.0316.8.01 | Min.800 mm | Max.899 mm | 5x |
| | 1742/90/A | B.0317.8.01 | Min.900 mm | Max.999 mm | 5x |
| | 1742/100/A | B.0318.8.01 | Min.1000 mm | Max.1099 mm | 5x |
| | 1742/120/A | B.0319.8.01 | Min.1200 mm | Max.1299 mm | 5x |

COVER / COPERTURA

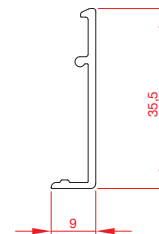
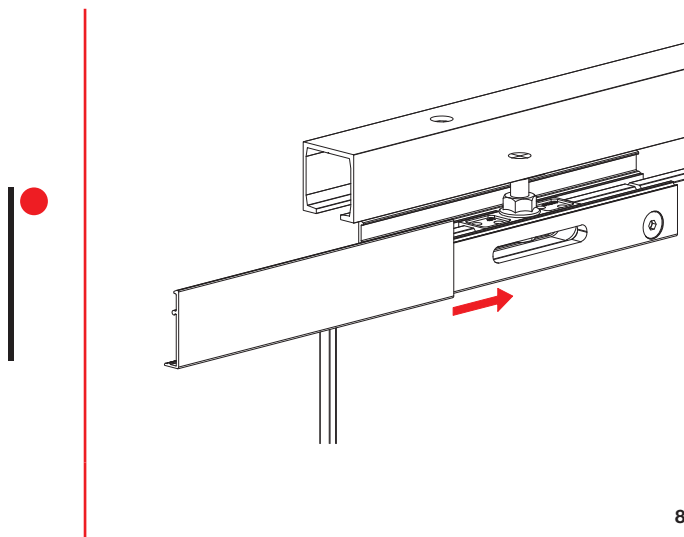

ART. 1742
8 02 0.01742



Vetro 40

Accessories for glass doors without drillings and clamp height 40 mm
Accessori per porte in vetro senza forature e pinza alta 40 mm







| | | |
|-------------|---|---|
| K | Complete kit for N°1 glass door with clamp height 40 mm / Kit completo per N°1 porta in vetro con pinza 40 mm | |
| B | Complete blister / Blister completo | |
| | | . |
| 0321 | | Blister (Glass thickness 8-8,7 mm - 5/16") Blister (Vetro spessore 8-8,7 mm - 5/16") |
| 0322 | | Blister (Glass thickness 10-10,7 mm - 3/8") Blister (Vetro spessore 10-10,7 mm - 3/8") |
| 0323 | | Blister (Glass thickness 12-12,7 mm - 1/2") Blister (Vetro spessore 12-12,7 mm - 1/2") |
| 0324 | | Kit (STEP bracket) Kit (Staffa STEP) |
| 0325 | | Kit (STEP bracket) Kit (Staffa STEP) |
| 0326 | | Accessories kit (Glass thickness 8-8,7 mm - 5/16") Kit accessori (Vetro spessore 8-8,7 mm - 5/16") |
| 0327 | | Accessories kit (Glass thickness 10-10,7 mm - 3/8") Kit accessori (Vetro spessore 10-10,7 mm - 3/8") |
| 0328 | | Accessories kit (Glass thickness 12-12,7 mm - 1/2") Kit accessori (Vetro spessore 12-12,7 mm - 1/2") |
| | | . |
| | | 0 No stoppers Senza fermi |
| | | 5 N.1 Fluid damper + N.1 Shock absorber N.1 Fermo Fluid + N.1 Fermo a pinza ammortizzato |
| | | 6 N.2 Fluid dampers N.2 Fermi ammortizzati Fluid |
| | | 7 N.2 Shock absorber N.2 Fermi a pinza ammortizzati |
| | | B With STEP bracket Con staffa STEP |
| | | C Without STEP bracket Senza staffa STEP |
| | | . |
| | C | With cover Con copertura |
| | S | Without cover Senza copertura |
| | C060 | Standard track 600 mm with cover Estruso standard 600 mm con copertura |
| | S060 | Standard track 600 mm Estruso standard 600 mm |
| | C070 | Standard track 700 mm with cover Estruso standard 700 mm con copertura |
| | S070 | Standard track 700 mm Estruso standard 700 mm |
| | C080 | Standard track 800 mm with cover Estruso standard 800 mm con copertura |
| | S080 | Standard track 800 mm Estruso standard 800 mm |
| | C090 | Standard track 900 mm with cover Estruso standard 900 mm con copertura |
| | S090 | Standard track 900 mm Estruso standard 900 mm |
| | C100 | Standard track 1000 mm with cover Estruso standard 1000 mm con copertura |
| | S100 | Standard track 1000 mm Estruso standard 1000 mm |
| | C120 | Standard track 1200 mm with cover Estruso standard 1200 mm con copertura |
| | S120 | Standard track 1200 mm Estruso standard 1200 mm |
| | C150 | Standard track 1500 mm with cover Estruso standard 1500 mm con copertura |
| | S150 | Standard track 1500 mm Estruso standard 1500 mm |

EXAMPLE / ESEMPIO

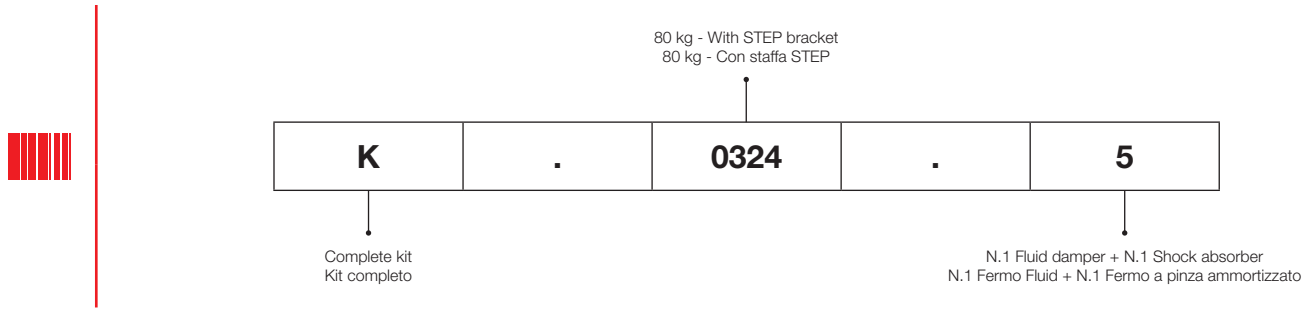

| Tracks / Binari | | ALUMINUM FINISHES CODES / CODICI FINITURE ALLUMINIO | | |
|-----------------|--------------------------------|---|--|----------|
| CODE / CODICE | FINISH COLOR / COLORE FINITURA | | | STANDARD |
| 8 01 0.0 | | 01 A | Anodized Silver / Argento | |
| 8 02 0.0 | | 02 AS | Brushed Anodized Silver / Argento Spazzolato | |

Vetro 40

Sliding system for glass doors with clamp height 40 mm
 Scorrevoli per porte in vetro con pinza alta 40 mm

CLAMP 200 - PINZA DA 200

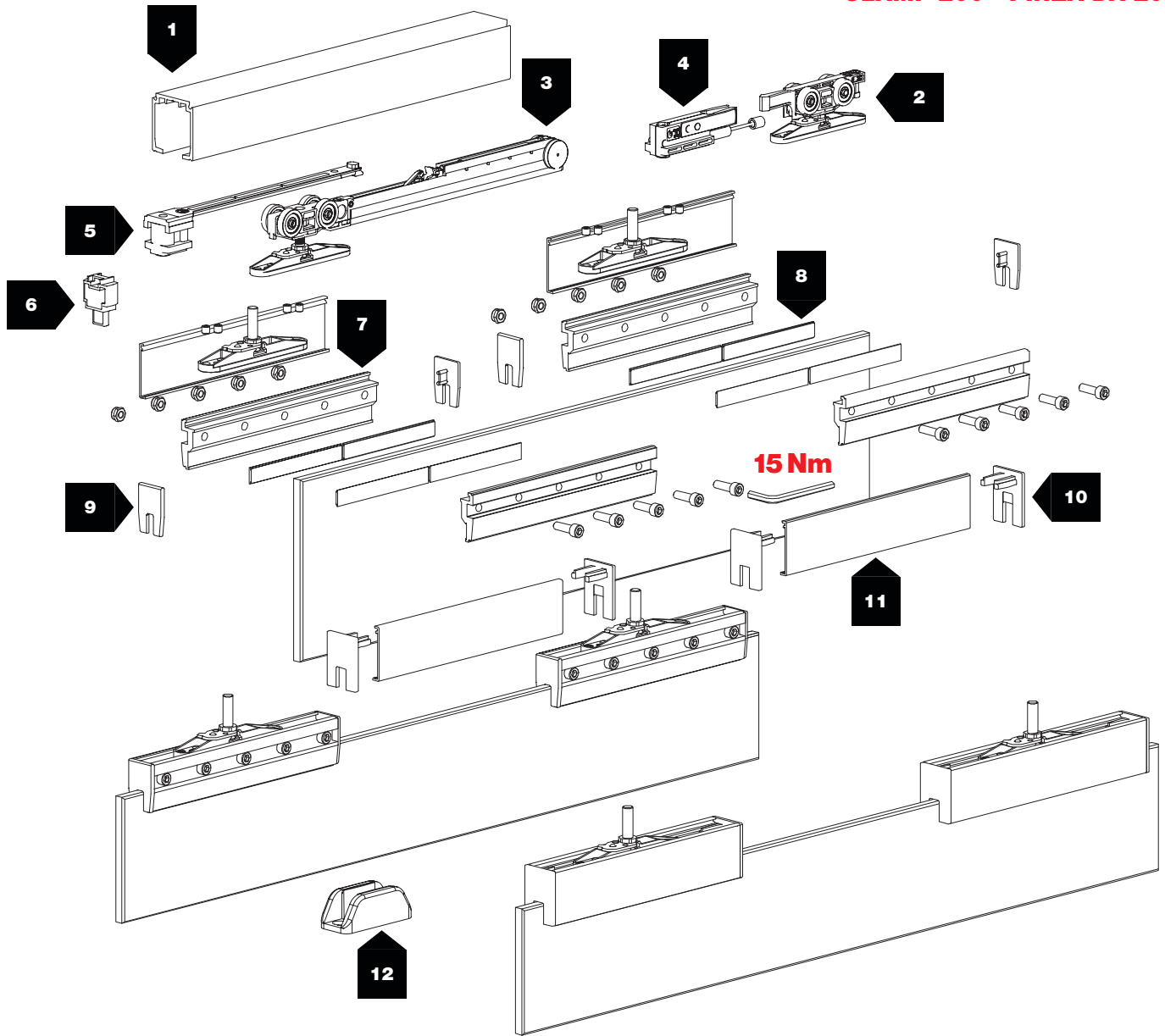

Position for trolley hooking
 Posizione per aggancio scorrevole



Position for trolley hooked
 Posizione con scorrevole agganciato

Security lockout
 Blocco di sicurezza

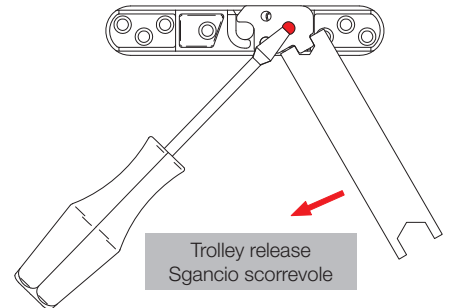

Trolley release
 Sgancio scorrevole







8-8,7 ÷ 12-12,7 mm



80 ÷ 120 kg

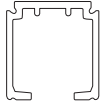
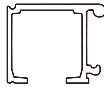
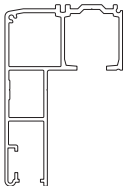

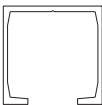
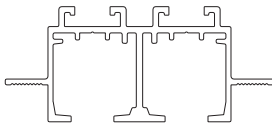

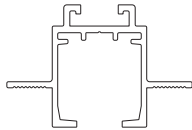
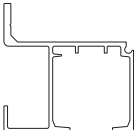
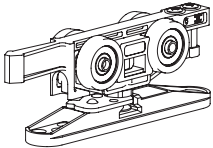





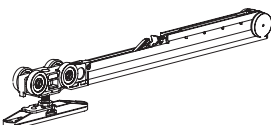

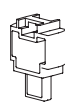
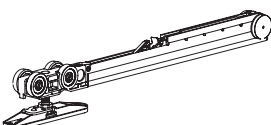

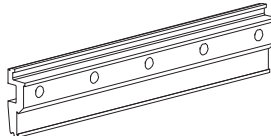
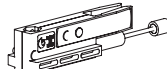

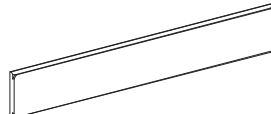
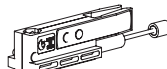
10 mm

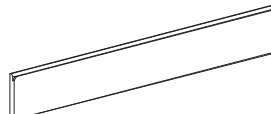
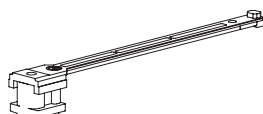
| N° | Barcode | | kg | | N° | Barcode | | kg | |
|----|----------------------|---|----|--|----|----------------------|---|---|---------------|
| 1 | 1280 8 01 0.01280 |  | - | | 1 | 1700 8 01 0.01700 |  | - | |
| | 1750 8 02 0.01750 |  | - | | | 1720 8 01 0.01720 |  | - | |
| | 1080 8 01 0.01080 |  | - | | | 1261 8 01 0.01261 |  | - | OPTIONAL + |
| | 1690 8 02 0.01690 |  | - | | | 1263 8 01 0.01263 |  | - | OPTIONAL + |
| | 1359 8 01 0.01359 |  | - | | | 2 | 3378/V40 |  | 80÷120 |

Vetro 40

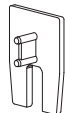
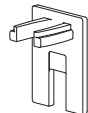
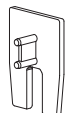
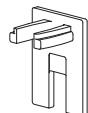
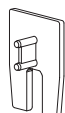
Sliding system for glass doors with clamp height 40 mm
Scorrevoli per porte in vetro con pinza alta 40 mm

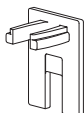
| N° | | | kg | | N° | | | kg | |
|----|--------------|---|--------|---|----|----------|---|----|---|
| 3 | 3372/080/V40 |  | 80 |  | 6 | 3347 |  | — | |
| | 3372/120/V40 |  | 120 |  | 7 | 1712/020 |  | — | |
| 4 | 3355/080 |  | 80 |  | 8 | 1707 |  | — | Glass thk. Vetri sp. 8-8,7 mm (5/16") |
| | 3355/120 |  | 120 |  | | 1704 |  | — | Glass thk. Vetri sp. 10-10,7 mm (3/8") |
| 5 | 3354 |  | 80÷120 |  | | 1705 |  | — | Glass thk. Vetri sp. 12-12,7 mm (1/2") |

| N° | | | kg | | N° | | | kg | |
|----|--------|---|----|---|----|---------|---|---|---|
| 9 | 1731 |  | — | Glass thk. Vetri sp. 8-8,7 mm (5/16") | 10 | 1701/10 |  | — | Glass thk. Vetri sp. 10-10,7 mm (3/8") |
| | 1733 |  | — | Glass thk. Vetri sp. 10-10,7 mm (3/8") | | 1701/12 |  | — | Glass thk. Vetri sp. 12-12,7 mm (1/2") |
| | 1737 |  | — | Glass thk. Vetri sp. 12-12,7 mm (1/2") | | 11 | 1703 8 02 0.01703 |  | — |
| 10 | 1701/8 |  | — | Glass thk. Vetri sp. 8-8,7 mm (5/16") | 12 | 1486 |  | 80 | |

LONG CLAMPS - PINZA LUNGA

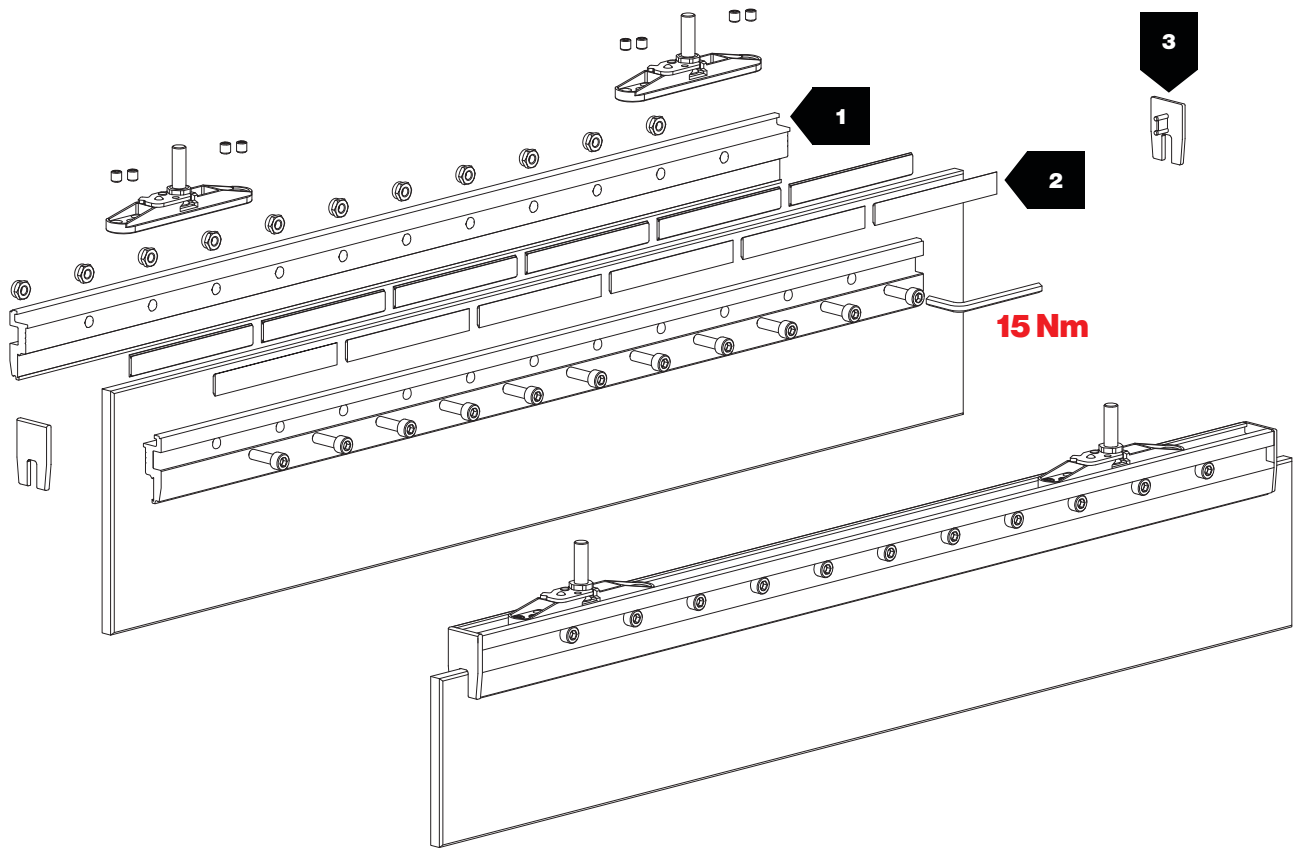

Position for trolley hooking
 Posizione per aggancio scorrevole



Position for trolley hooked
 Posizione con scorrevole agganciato

Security lockout
 Blocco di sicurezza

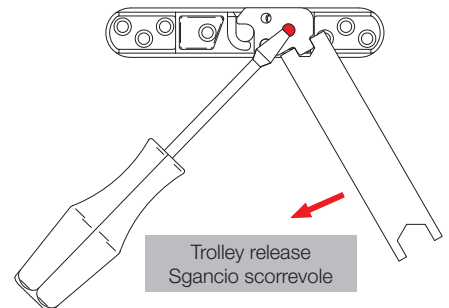

Trolley release
 Sgancio scorrevole



8-8,7 ÷ 12-12,7 mm



80 ÷ 120 kg



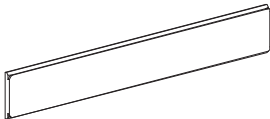
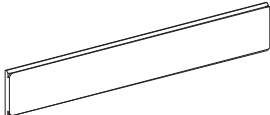
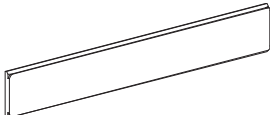
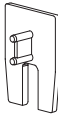
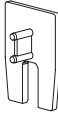
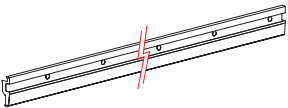
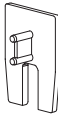

10 mm

| N° | | | kg | | N° | | | kg | | |
|----------|----------|---|----|--|----|------|---|---|---|---|
| 1 | 1712/A |  | — | | 2 | 1707 |  | — | Glass thk. Vetri sp. 8-8,7 mm (5/16") | |
| | | | | | | 1704 |  | — | Glass thk. Vetri sp. 10-10,7 mm (3/8") | |
| | | | | | | 1705 |  | — | Glass thk. Vetri sp. 12-12,7 mm (1/2") | |
| | 1712/060 | | | | 3 | 1731 |  | — | Glass thk. Vetri sp. 8-8,7 mm (5/16") | |
| | 1712/070 | | | | | | | | | |
| | 1712/080 | | | | | | 1733 |  | — | Glass thk. Vetri sp. 10-10,7 mm (3/8") |
| | 1712/090 |  | — | | | | | | | |
| | 1712/100 | | | | | | 1737 |  | — | Glass thk. Vetri sp. 12-12,7 mm (1/2") |
| 1712/120 | | | | | | | | | | |
| 1712/150 | | | | | | | | | | |



Vetro 40

Sliding system for glass doors with clamp height 40 mm
Scorrevoli per porte in vetro con pinza alta 40 mm

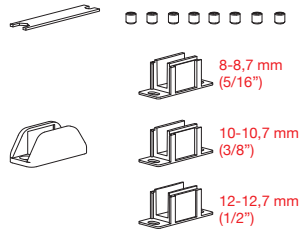

FLUID

-  N.2 Shock absorbers
N.2 Fermi a pinza ammortizzati
-  Ball bearings
Cuscinetti a sfera





| OLD CODE | NEW CODE |  |  |  |
|----------|----------|--|---|---|
| — | K.0324.7 | 80 kg | Min. 600 mm | 5x |
| — | K.0325.7 | 120 kg | | 5x |

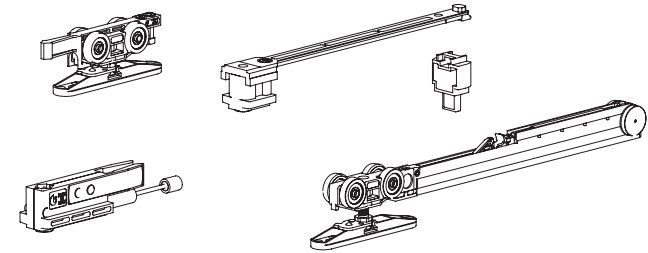
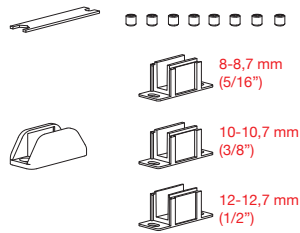

FLUID

-  N.1 Fluid damper
N.1 Fermo ammortizzato
Fluid
-  N.1 Shock absorber
N.1 Fermo a pinza ammortizzato
-  Ball bearings
Cuscinetti a sfera





| OLD CODE | NEW CODE |  |  |  |
|----------|----------|--|---|---|
| — | K.0324.5 | 80 kg | Min. 600 mm | 4x |
| — | K.0325.5 | 120 kg | | 4x |

FLUID

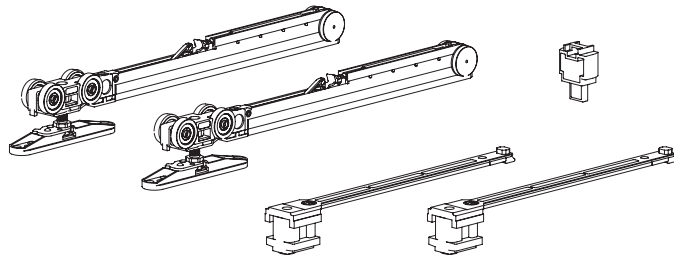
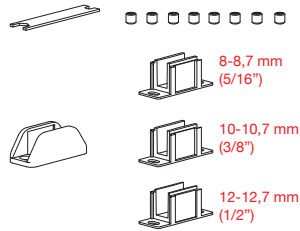
-  N.2 Fluid dampers
N.2 Fermi ammortizzati
Fluid
-  Ball bearings
Cuscinetti a sfera



| OLD CODE | NEW CODE |  |  |  |
|----------|----------|--|---|---|
| — | K.0324.6 | 80 kg | Min. 740 mm | 4x |
| — | K.0325.6 | 120 kg | | 4x |

MEASUREMENTS DESCRIPTION / DESCRIZIONI MISURE

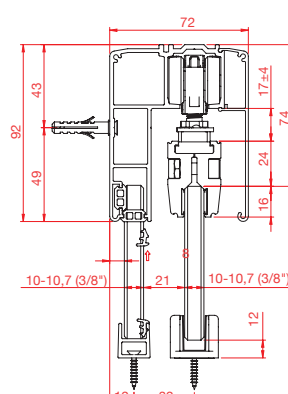
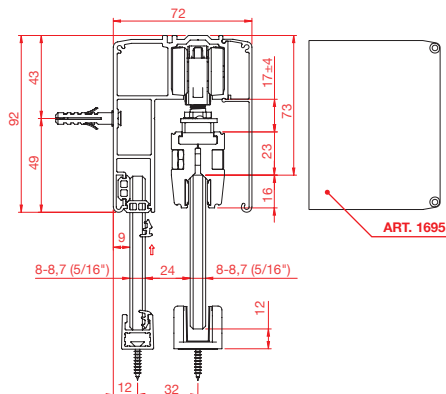
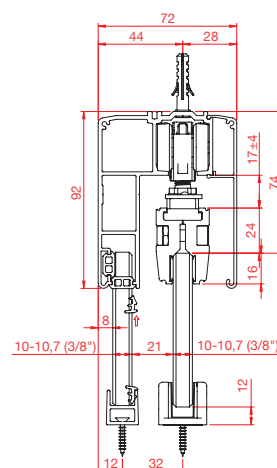
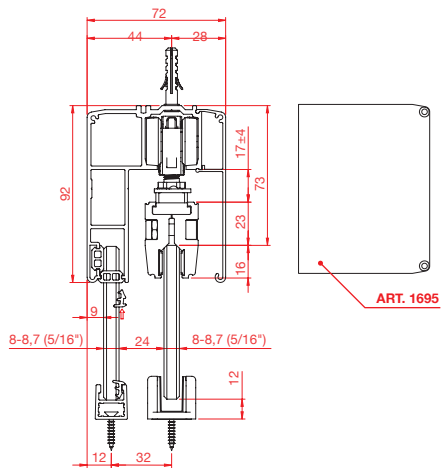
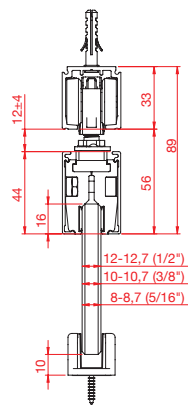
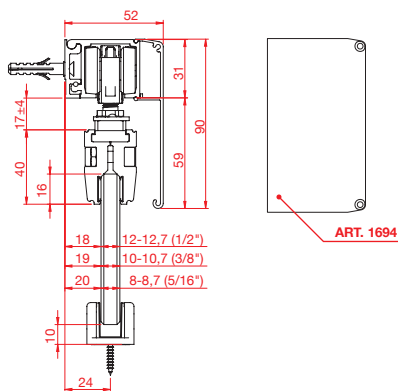
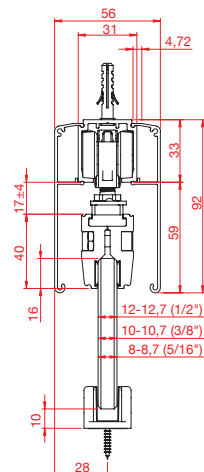
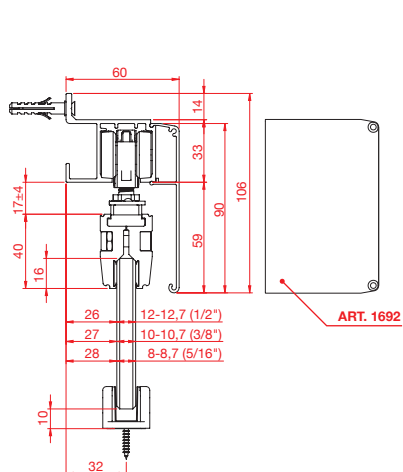

Vetro 40

Sliding system for glass doors with clamp height 40 mm
Scorrevoli per porte in vetro con pinza alta 40 mm



120 kg



Without cover
Senza copertura



Anodized Silver finish
Finitura Argento

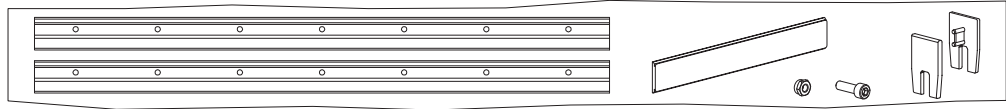

| BLISTER | OLD CODE | NEW CODE | 8-8,7 mm (5/16") | 600 ÷ 699 mm | SPACERS DISTANZIALI | |
|---------------|---------------|----------------|----------------------|----------------|---------------------|-----|
| | | | | | N° | MIN |
| BLISTER | 1712/8/060/A | B.0321.0.S060 | 8-8,7 mm (5/16") | 600 ÷ 699 mm | N° 12 | 5x |
| | 1712/8/070/A | B.0321.0.S070 | | 700 ÷ 799 mm | N° 14 | 5x |
| | 1712/8/080/A | B.0321.0.S080 | | 800 ÷ 899 mm | N° 16 | 5x |
| | 1712/8/090/A | B.0321.0.S090 | | 900 ÷ 999 mm | N° 18 | 5x |
| | 1712/8/100/A | B.0321.0.S100 | | 1000 ÷ 1099 mm | N° 20 | 5x |
| | 1712/8/120/A | B.0321.0.S120 | | 1200 ÷ 1299 mm | N° 24 | 5x |
| BLISTER | 1712/8/150/A | B.0321.0.S150 | 1500 ÷ 1600 mm | N° 30 | 5x | |
| | 1712/10/060/A | B.0322.0.S060 | 10-10,7 mm (3/8") | 600 ÷ 699 mm | N° 12 | 5x |
| | 1712/10/070/A | B.0322.0.S070 | | 700 ÷ 799 mm | N° 14 | 5x |
| | 1712/10/080/A | B.0322.0.S080 | | 800 ÷ 899 mm | N° 16 | 5x |
| | 1712/10/090/A | B.0322.0.S090 | | 900 ÷ 999 mm | N° 18 | 5x |
| | 1712/10/100/A | B.0322.0.S100 | | 1000 ÷ 1099 mm | N° 20 | 5x |
| 1712/10/120/A | B.0322.0.S120 | 1200 ÷ 1299 mm | | N° 24 | 5x | |
| BLISTER | 1712/10/150/A | B.0322.0.S150 | 1500 ÷ 1600 mm | N° 30 | 5x | |
| | 1712/12/060/A | B.0323.0.S060 | 12-12,7 mm (1/2") | 600 ÷ 699 mm | N° 12 | 5x |
| | 1712/12/070/A | B.0323.0.S070 | | 700 ÷ 799 mm | N° 14 | 5x |
| | 1712/12/080/A | B.0323.0.S080 | | 800 ÷ 899 mm | N° 16 | 5x |
| | 1712/12/090/A | B.0323.0.S090 | | 900 ÷ 999 mm | N° 18 | 5x |
| | 1712/12/100/A | B.0323.0.S100 | | 1000 ÷ 1099 mm | N° 20 | 5x |
| 1712/12/120/A | B.0323.0.S120 | 1200 ÷ 1299 mm | | N° 24 | 5x | |
| BLISTER | 1712/12/150/A | B.0323.0.S150 | 1500 ÷ 1600 mm | N° 30 | 5x | |



120 kg



With cover
Con copertura



Anodized Silver finish
Finitura Argento

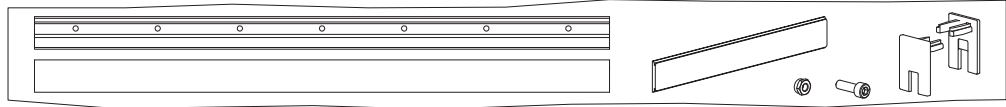

| BLISTER | OLD CODE | NEW CODE | 8-8,7 mm (5/16") | 600 ÷ 699 mm | SPACERS DISTANZIALI | |
|----------------|----------------|----------------|----------------------|----------------|---------------------|-----|
| | | | | | N° | MIN |
| BLISTER | 1712/8/060/AC | B.0321.0.C060 | 8-8,7 mm (5/16") | 600 ÷ 699 mm | N° 12 | 5x |
| | 1712/8/070/AC | B.0321.0.C070 | | 700 ÷ 799 mm | N° 14 | 5x |
| | 1712/8/080/AC | B.0321.0.C080 | | 800 ÷ 899 mm | N° 16 | 5x |
| | 1712/8/090/AC | B.0321.0.C090 | | 900 ÷ 999 mm | N° 18 | 5x |
| | 1712/8/100/AC | B.0321.0.C100 | | 1000 ÷ 1099 mm | N° 20 | 5x |
| | 1712/8/120/AC | B.0321.0.C120 | | 1200 ÷ 1299 mm | N° 24 | 5x |
| BLISTER | 1712/8/150/AC | B.0321.0.C150 | 1500 ÷ 1600 mm | N° 30 | 5x | |
| | 1712/10/060/AC | B.0322.0.C060 | 10-10,7 mm (3/8") | 600 ÷ 699 mm | N° 12 | 5x |
| | 1712/10/070/AC | B.0322.0.C070 | | 700 ÷ 799 mm | N° 14 | 5x |
| | 1712/10/080/AC | B.0322.0.C080 | | 800 ÷ 899 mm | N° 16 | 5x |
| | 1712/10/090/AC | B.0322.0.C090 | | 900 ÷ 999 mm | N° 18 | 5x |
| | 1712/10/100/AC | B.0322.0.C100 | | 1000 ÷ 1099 mm | N° 20 | 5x |
| 1712/10/120/AC | B.0322.0.C120 | 1200 ÷ 1299 mm | | N° 24 | 5x | |
| BLISTER | 1712/10/150/AC | B.0322.0.C150 | 1500 ÷ 1600 mm | N° 30 | 5x | |
| | 1712/12/060/AC | B.0323.0.C060 | 12-12,7 mm (1/2") | 600 ÷ 699 mm | N° 12 | 5x |
| | 1712/12/070/AC | B.0323.0.C070 | | 700 ÷ 799 mm | N° 14 | 5x |
| | 1712/12/080/AC | B.0323.0.C080 | | 800 ÷ 899 mm | N° 16 | 5x |
| | 1712/12/090/AC | B.0323.0.C090 | | 900 ÷ 999 mm | N° 18 | 5x |
| | 1712/12/100/AC | B.0323.0.C100 | | 1000 ÷ 1099 mm | N° 20 | 5x |
| 1712/12/120/AC | B.0323.0.C120 | 1200 ÷ 1299 mm | | N° 24 | 5x | |
| BLISTER | 1712/12/150/AC | B.0323.0.C150 | 1500 ÷ 1600 mm | N° 30 | 5x | |

ART. 1712

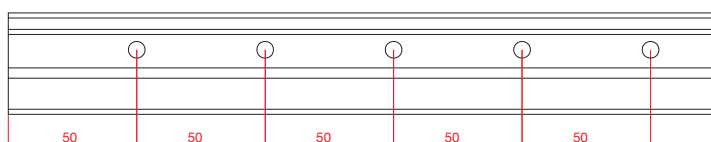

ACCESSORIES FOR KITS OF PAG. 12 / ACCESSORI PER I KIT DI PAG. 12

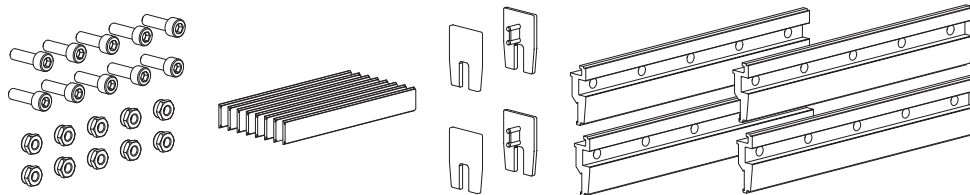



120 kg



Without cover
Senza copertura



Anodized Silver finish
Finitura Argento

| KIT | OLD CODE | NEW CODE |  |  |
|-----|---------------|--------------|---|---|
| | | 1712/8/020/A | K.0326.C.S | 8-8,7 mm (5/16") |
| | 1712/10/020/A | K.0327.C.S | 10-10,7 mm (3/8") | 5x |
| | 1712/12/020/A | K.0328.C.S | 12-12,7 mm (1/2") | 5x |

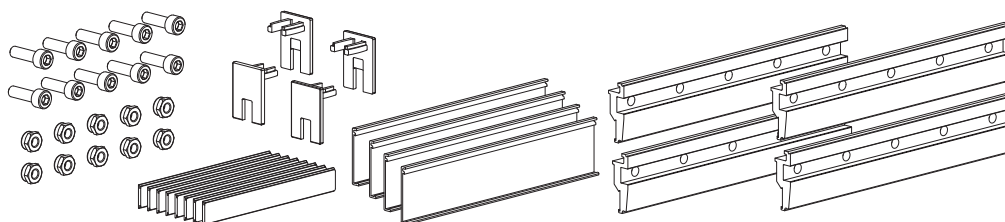



120 kg



With cover
Con copertura



Anodized Silver finish
Finitura Argento

| KIT | OLD CODE | NEW CODE |  |  |
|-----|----------------|---------------|---|---|
| | | 1712/8/020/AC | K.0326.C.C | 8-8,7 mm (5/16") |
| | 1712/10/020/AC | K.0327.C.C | 10-10,7 mm (3/8") | 5x |
| | 1712/12/020/AC | K.0328.C.C | 12-12,7 mm (1/2") | 5x |

KIT FOR COUNTERFRAMES / KIT PER CONTROTELAII

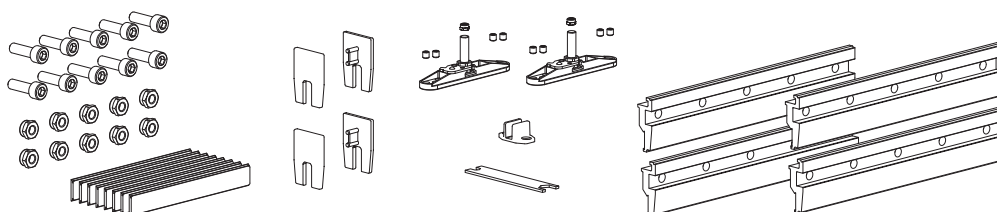



120 kg



Without cover
Senza copertura



Anodized Silver finish
Finitura Argento

| KIT | OLD CODE | NEW CODE |  |  |
|-----|-----------------|----------------|---|---|
| | | 1712/8/020/ASB | K.0326.B.S | 8-8,7 mm (5/16") |
| | 1712/10/020/ASB | K.0327.B.S | 10-10,7 mm (3/8") | 5x |
| | 1712/12/020/ASB | K.0328.B.S | 12-12,7 mm (1/2") | 5x |

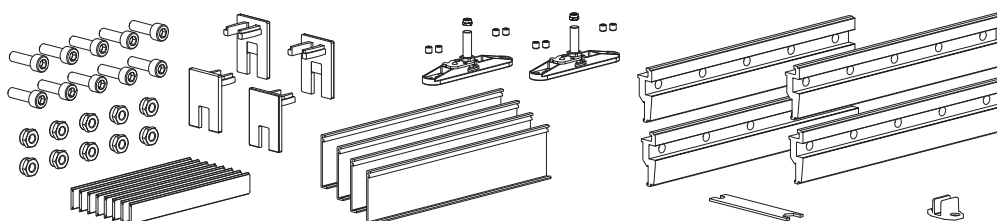



120 kg



With cover
Con copertura



Anodized Silver finish
Finitura Argento

| KIT | OLD CODE | NEW CODE |  |  |
|-----|------------------|-----------------|---|---|
| | | 1712/8/020/ACSB | K.0326.B.C | 8-8,7 mm (5/16") |
| | 1712/10/020/ACSB | K.0327.B.C | 10-10,7 mm (3/8") | 5x |
| | 1712/12/020/ACSB | K.0328.B.C | 12-12,7 mm (1/2") | 5x |



Vetro 40 Drag

Mechanisms for manual telescopic glass doors
Meccanismi per porte in vetro a trascinamento





Sliding system suitable for drag glass door

Vetro 40 Drag is a sliding system suitable for drag glass door with a **reduced height clamp** (only 40 mm). The system is available with full-length clamping system that can be cut to size at a later time.

The system is compatible with monolithic or laminated glass, with thicknesses of 8-8,7 (5/16") mm and 10-10,7 mm (3/8").

Vetro 40 Drag integrates the new sliding trolleys with **Fluid** technology: the movement turns out to be extremely soft, in opening and closing, for a constantly improved user experience.

Sistema scorrevole per porte in vetro a trascinamento



Vetro 40 Drag è il sistema scorrevole per porte in vetro a trascinamento con **pinza ad altezza ridotta** (solo 40 mm). Il sistema è disponibile con pinza a tutta lunghezza: la pinza può essere successivamente tagliata a misura.

Il sistema è compatibile con vetri monolitici o stratificati, con spessori da 8-8,7 mm (5/16") e 10-10,7 mm (3/8").

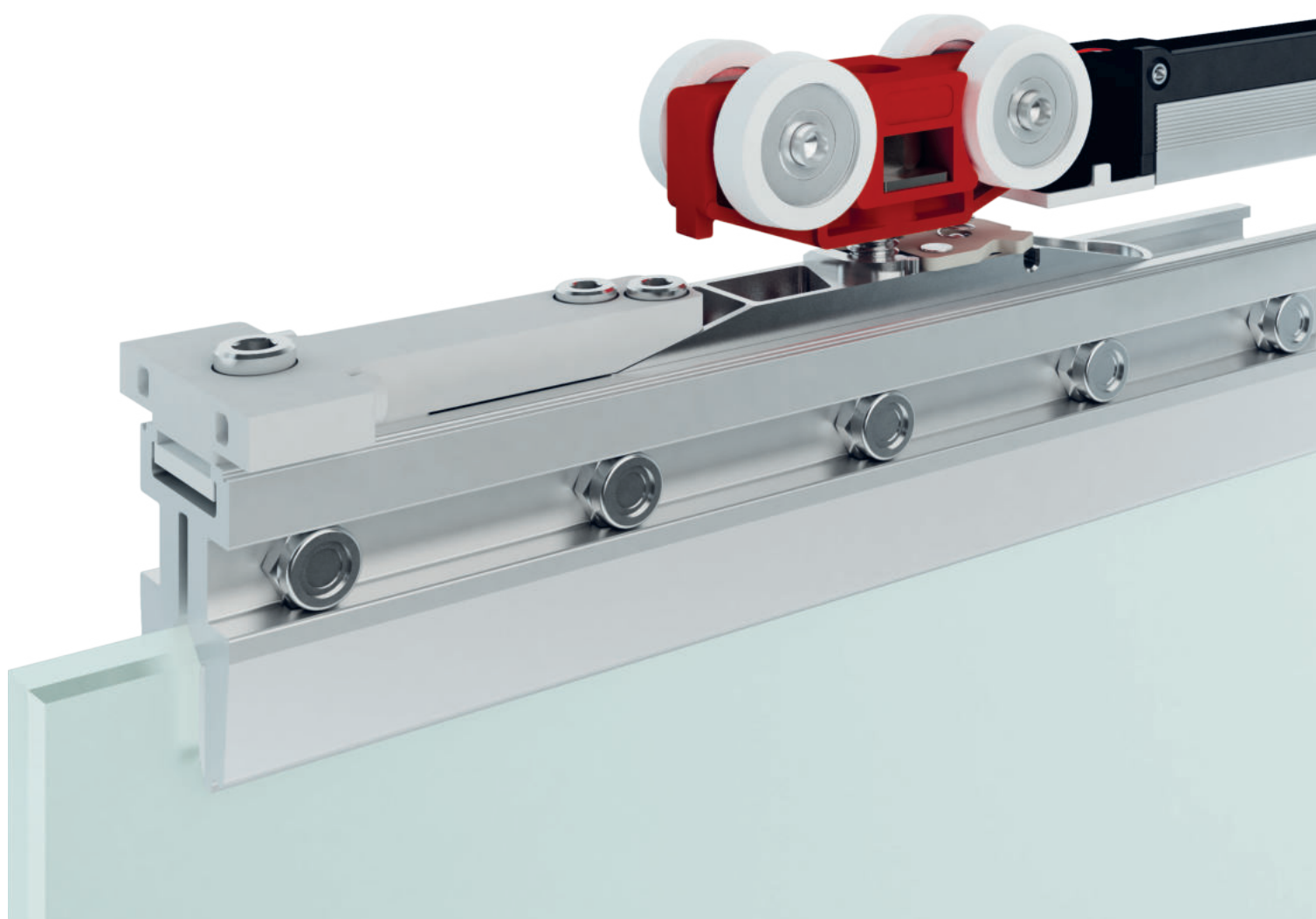
Vetro 40 Drag integra i nuovi scorrevoli con tecnologia **Fluid**: il movimento risulta così estremamente morbido, in apertura e in chiusura, per un'esperienza ancora migliore.



Vetro 40 Drag COMPLETE BOX KIT / KIT COMPLETO IN SCATOLA 

| | | | |
|----------|---|--|--|
| K | Complete kit for N°1 manual telescopic glass door / Kit completo per N°1 porta in vetro a trascinamento | | |
| | . | | |
| | 0341 |  With floor guide and drag guide Con guida a pavimento e trascinamento | A |
| | 0342 |  With drag guide Con guida a trascinamento | B |
| | 0343 |  Without guides Senza guida | C |
| | | . | |
| | | | 5 N.1 Fluid damper + N.1 Shock absorber N.1 Fermo Fluid + N.1 Fermo a pinza ammortizzato |
| | | | 6 N.2 Fluid dampers N.2 Fermi ammortizzati Fluid |
| | | | 7 N.2 Shock absorber N.2 Fermi a pinza ammortizzati |

EXAMPLE / ESEMPIO

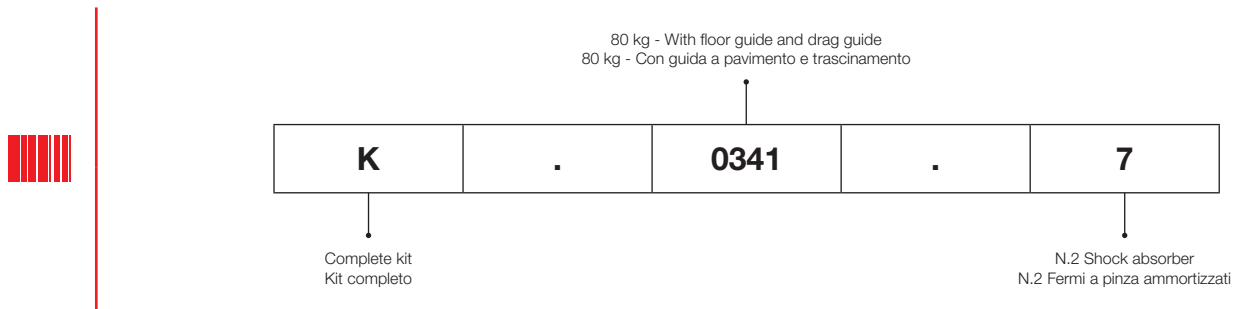

Tracks / Binari ALUMINUM FINISHES CODES / CODICI FINITURE ALLUMINIO 

| CODE / CODICE | FINISH COLOR / COLORE FINITURA | | |
|-----------------------|---|---|-----------------|
| 8 01 0.0 |  | 01 A Anodized Silver / Argento | STANDARD |
| 8 02 0.0 |  | 02 AS Brushed Anodized Silver / Argento Spazzolato | |

Vetro 40 Drag

Manual telescopic glass doors
Porte a trascinamento in vetro

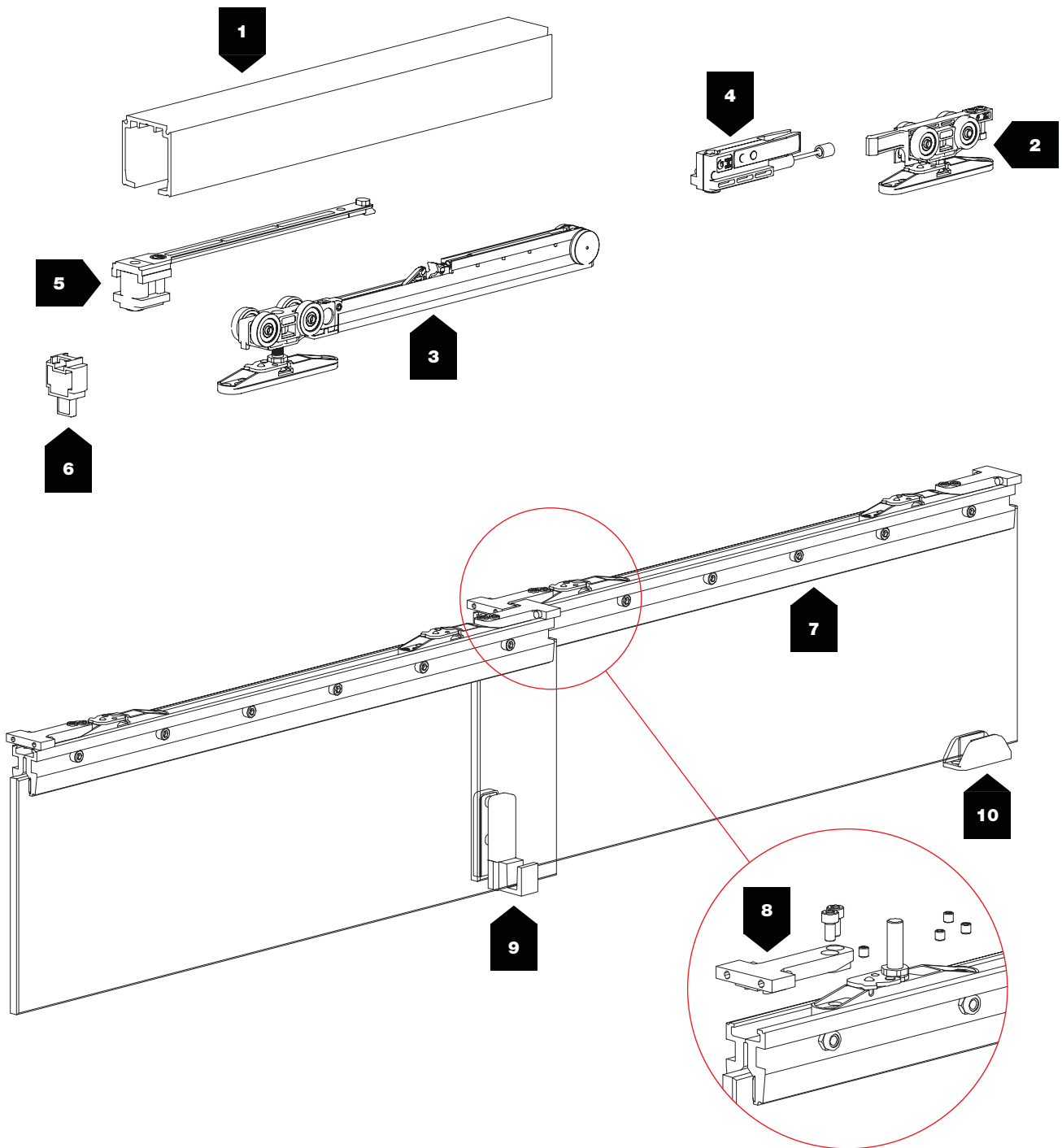









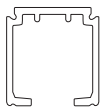

8-8,7 ÷ 10-10,7 mm

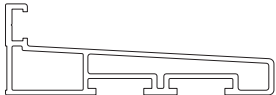
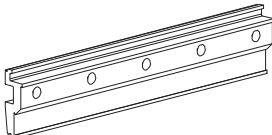
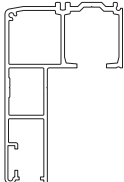
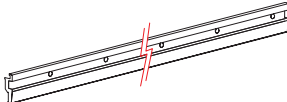
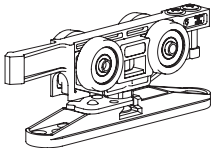

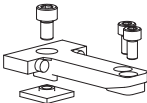
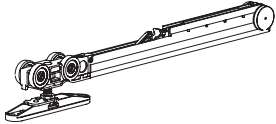
80 kg

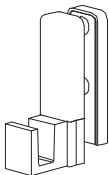
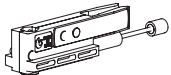

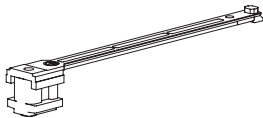
10 mm

| N° | Barcode | | kg | | N° | Barcode | | kg | | |
|----|----------------------|---|----|---|----------|-----------|---|----|---|--|
| 1 | 1280 8 01 0.01280 |  | - | | 6 | 3347 |  | - | | |
| | 1770 8 01 0.01770 |  | - | | 7 | 1712/020 |  | - | | |
| | 1750 8 02 0.01750 |  | - | | | 1712/060 |  | - | | |
| | | | | 1712/070 | | | | | | |
| | | | | | | 1712/080 | | | | |
| | | | | | | 1712/090 | | | | |
| | | | | | | 1712/100 | | | | |
| | | | | | 1712/120 | | | | | |
| | | | | | 1712/150 | | | | | |
| 2 | 3378/V40 |  | 80 |  | 8 | 1716 |  | - | | |
| 3 | 3372/080/V40 |  | 80 |  | 9 | 1718/8/10 |  | - | | |
| 4 | 3355/080 |  | 80 |  | 10 | 1486/8 |  | 80 | Glass thk. Vetri sp. 8-8,7 mm (5/16") | |
| 5 | 3354 |  | 80 |  | | 1486/10 |  | 80 | Glass thk. Vetri sp. 10-10,7 mm (3/8") | |

SYSTEMS DESCRIPTION / DESCRIZIONI SISTEMI

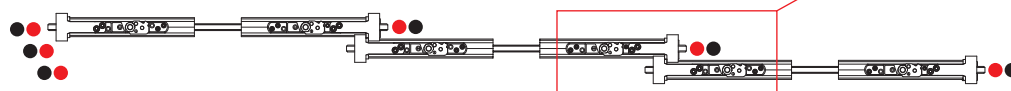
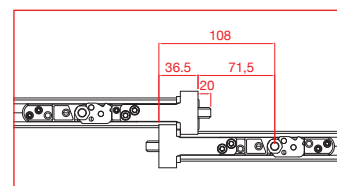
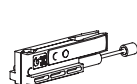
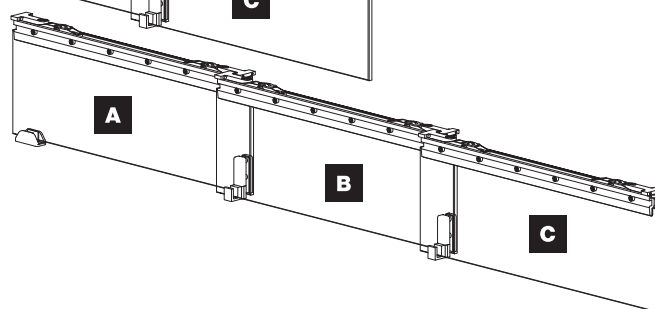
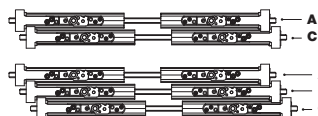
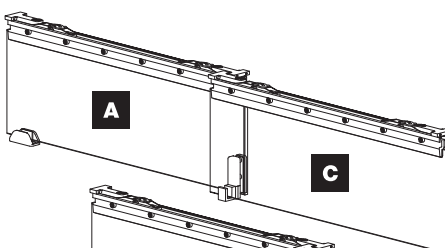
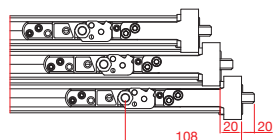
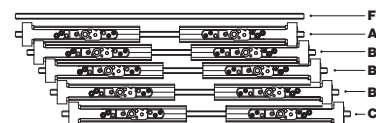
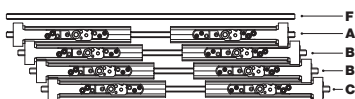
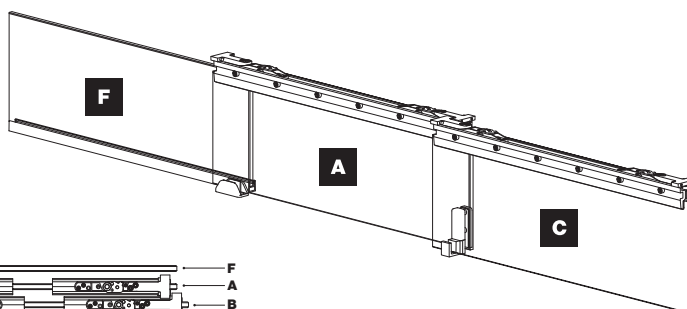
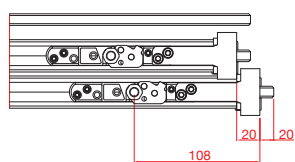
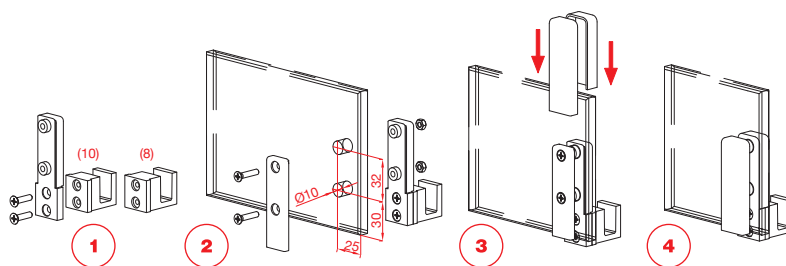
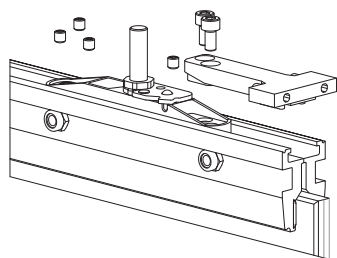

FLUID

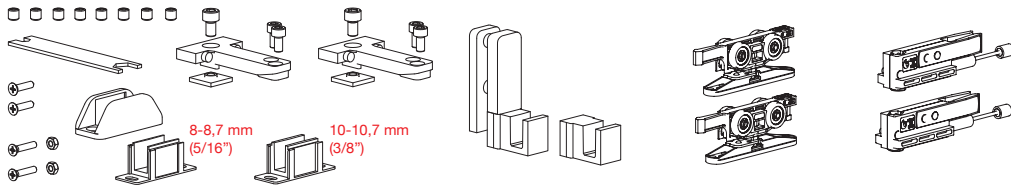

N.2 Shock absorbers
N.2 Fermi a pinza
ammortizzati



Ball bearings
Cuscinetti a sfera

| OLD CODE | NEW CODE | | | | | |
|----------|----------|----------|---------------------------------------|--------------|-------------|----|
| - | K.0341.7 | A | 8-8,7 mm (5/16") 10-10,7 mm (3/8") | 80 kg | Min. 600 mm | 5x |

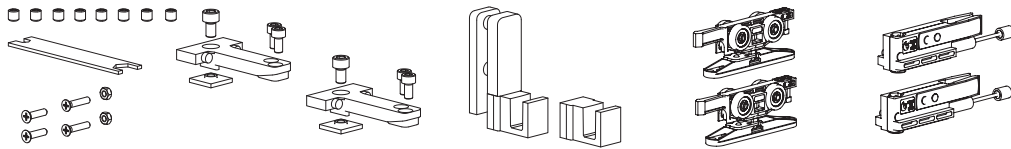

| OLD CODE | NEW CODE | | | | | |
|----------|----------|----------|---------------------------------------|--------------|-------------|----|
| - | K.0342.7 | B | 8-8,7 mm (5/16") 10-10,7 mm (3/8") | 80 kg | Min. 600 mm | 5x |

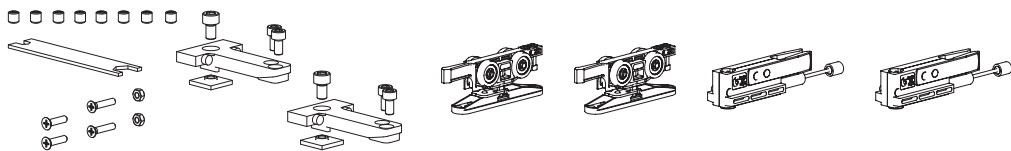

| OLD CODE | NEW CODE | | | | | |
|----------|----------|----------|---------------------------------------|--------------|-------------|----|
| - | K.0343.7 | C | 8-8,7 mm (5/16") 10-10,7 mm (3/8") | 80 kg | Min. 600 mm | 5x |

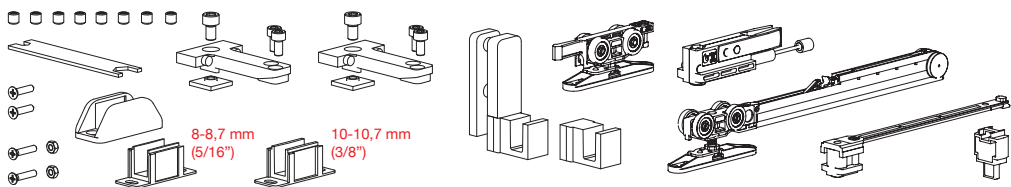

N.1 Fluid damper
N.1 Fermo ammortizzato
Fluid



N.1 Shock absorber
N.1 Fermo a pinza
ammortizzato



Ball bearings
Cuscinetti a sfera

FLUID

| OLD CODE | NEW CODE | | | | | |
|----------|----------|----------|---------------------------------------|--------------|-------------|----|
| - | K.0341.5 | A | 8-8,7 mm (5/16") 10-10,7 mm (3/8") | 80 kg | Min. 650 mm | 5x |

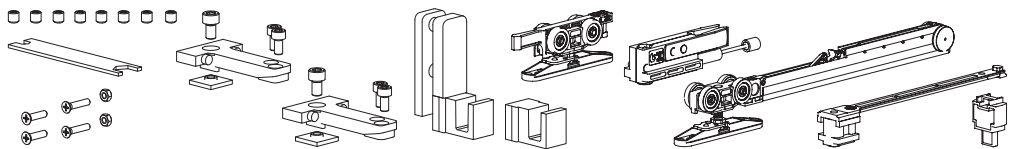

| OLD CODE | NEW CODE | | | | | |
|----------|----------|----------|---------------------------------------|--------------|-------------|----|
| - | K.0342.5 | B | 8-8,7 mm (5/16") 10-10,7 mm (3/8") | 80 kg | Min. 650 mm | 5x |

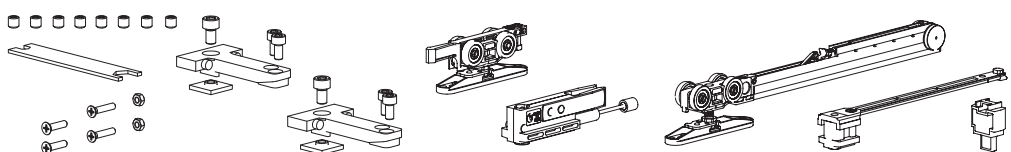



| OLD CODE | NEW CODE | | | | | |
|----------|----------|----------|---------------------------------------|--------------|-------------|----|
| - | K.0343.5 | C | 8-8,7 mm (5/16") 10-10,7 mm (3/8") | 80 kg | Min. 650 mm | 5x |

Vetro 40 Drag





Manual telescopic glass doors
Porte a trascinamento in vetro

FLUID

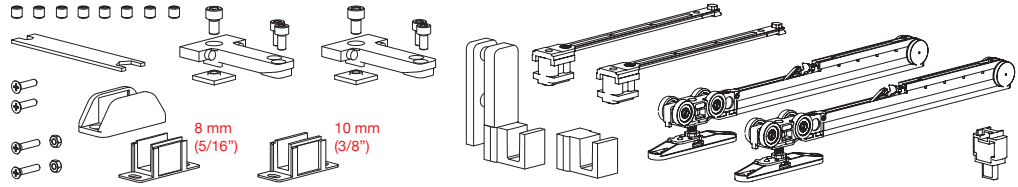
 N.2 Fluid dampers
 N.2 Fermi ammortizzati
 Fluid

 Ball bearings
 Cuscinetti a sfera



| OLD CODE | NEW CODE |  |  |  |  |
|----------|----------|---|---|---|---|
| — | K.0341.6 | A | 8-8,7 mm (5/16") 10-10,7 mm (3/8") | 80 kg | Min. 840 mm 5x |

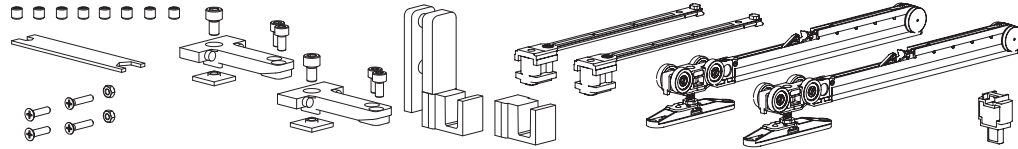

| OLD CODE | NEW CODE |  |  |  |  |
|----------|----------|---|---|---|---|
| — | K.0342.6 | B | 8-8,7 mm (5/16") 10-10,7 mm (3/8") | 80 kg | Min. 840 mm 5x |

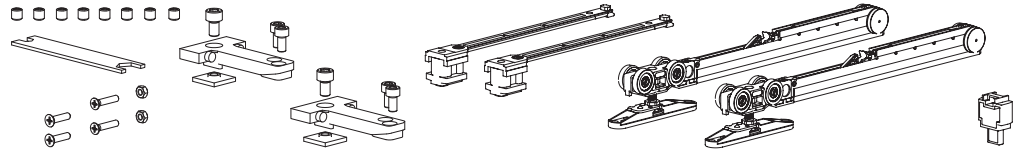

| OLD CODE | NEW CODE |  |  |  |  |
|----------|----------|--|--|--|--|
| — | K.0343.6 | C | 8-8,7 mm (5/16") 10-10,7 mm (3/8") | 80 kg | Min. 840 mm 5x |

MEASUREMENTS DESCRIPTION / DESCRIZIONI MISURE

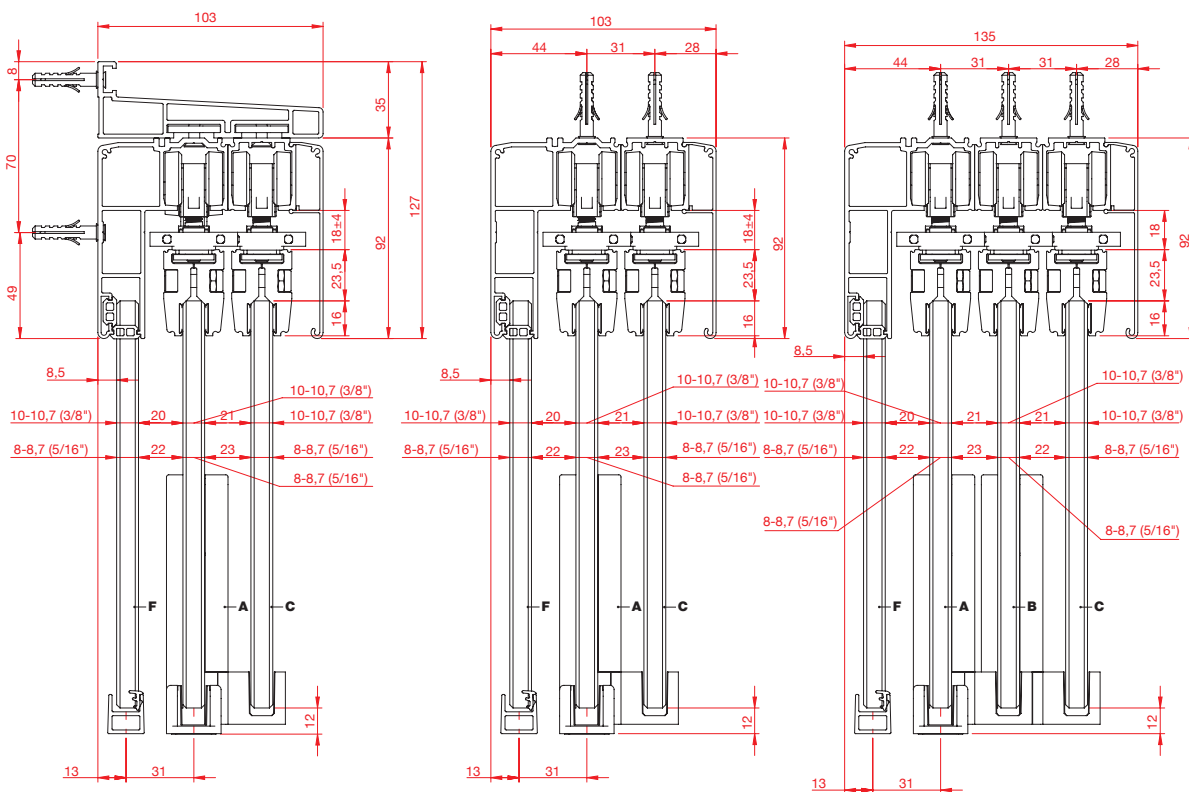



Vetro 40 Sync

Mechanisms for glass doors with simultaneous opening
Meccanismi per porte con apertura simultanea in vetro





Vetro 40 Sync is a **sliding system suitable for synchronized opening glass door with a reduced height clamp** (only 40 mm). The system is available with full-length clamping system that can be cut to size at a later time.

The system is **compatible with monolithic or laminated glass**, with thicknesses of 8-8,7 mm (5/16"), 10-10,7 mm (3/8") and 12-12,7 mm (1/2").



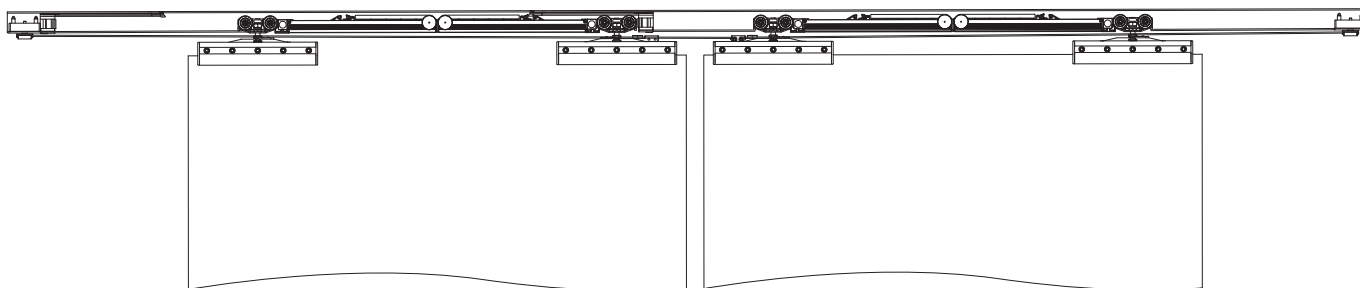

Vetro 40 Sync integrates the new sliding trolleys with **Fluid** technology: the movement turns out to be extremely soft, in opening and closing, for a constantly improved user experience.



Vetro 40 Sync è il **sistema scorrevole per porte in vetro ad apertura simultanea con pinza ad altezza ridotta** (solo 40 mm). Il sistema è disponibile con pinza a tutta lunghezza: la pinza può essere successivamente tagliata a misura.

Il sistema è **compatibile con vetri monolitici o stratificati**, con spessori da 8-8,7 mm (5/16"), 10-10,7 mm (3/8") e 12-12,7 mm (1/2").

Vetro 40 Sync integra i nuovi scorrevoli con tecnologia **Fluid**: il movimento risulta così estremamente morbido, in apertura e in chiusura, per un'esperienza di utilizzo sempre migliorata.

| Vetro 40 Sync | | COMPLETE BOX KIT / KIT COMPLETO IN SCATOLA | |  |
|----------------------|-----------------------------|--|---|---|
| K | Complete kit / Kit completo | | | |
| | | | | |
| | | 0334 |  With STEP bracket - Glass thickness 8-8,7 mm - 5/16" Con staffa STEP - Vetro spessore 8-8,7 mm - 5/16" | |
| | | 0335 |  With STEP bracket - Glass thickness 10-10,7 mm - 3/8" Con staffa STEP - Vetro spessore 10-10,7 mm - 3/8" | |
| | | 0336 |  With STEP bracket - Glass thickness 12-12,7 mm - 1/2" Con staffa STEP - Vetro spessore 12-12,7 mm - 1/2" | |
| | | | | |
| | | | | 6 N.4 Fluid dampers N.4 Fermi ammortizzati Fluid |

EXAMPLE / ESEMPIO

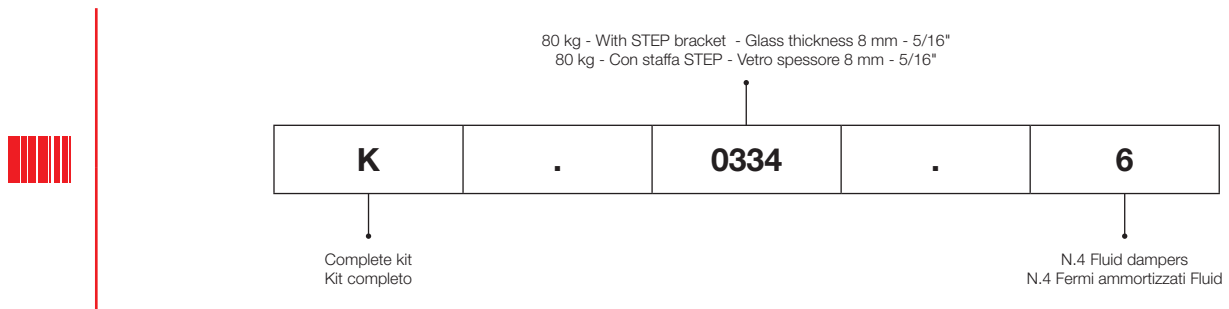

| Tracks / Binari | | ALUMINUM FINISHES CODES / CODICI FINITURE ALLUMINIO | |  |
|------------------------|-------------|---|-----------------|---|
| CODE / CODICE | | FINISH COLOR / COLORE FINITURA | | |
| 8 01 0.0 | 01 A | Anodized Silver / Argento | STANDARD | |

Vetro 40 Sync

Simultaneous glass doors
Porte simultanee in vetro

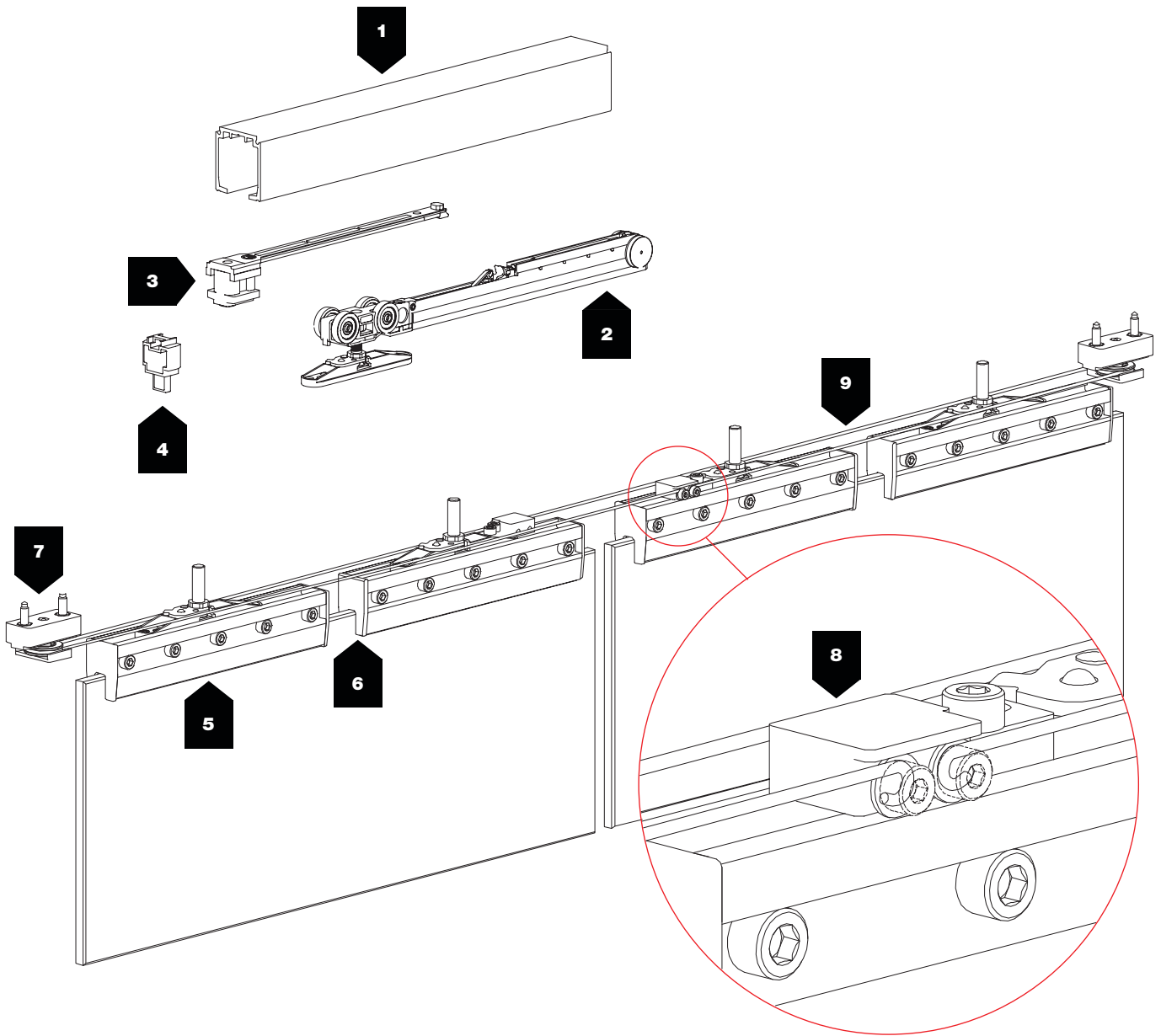







8-8,7 ÷ 12-12,7 mm

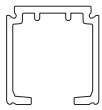
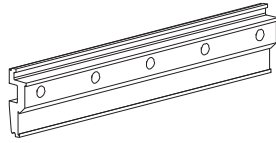
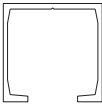
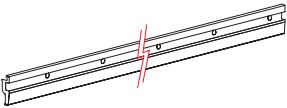
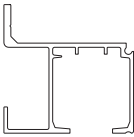

80 kg

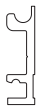
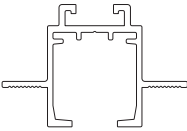
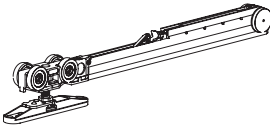
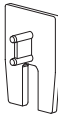
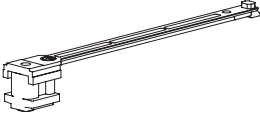
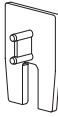

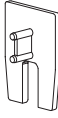
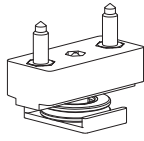
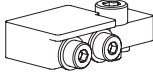

10 mm

| N° | Barcode | | kg | | N° | Barcode | | kg | |
|----|----------------------|---|----|---------------|----|----------|---|----|---|
| 1 | 1280 8 01 0.01280 |  | - | | 5 | 1712/020 |  | - | |
| | 1080 8 01 0.01080 |  | - | | | 1712/060 |  | - | |
| | 1359 8 01 0.01359 |  | - | | | 1712/070 | | - | |
| | 1700 8 01 0.01700 |  | - | | | 1712/080 | | - | |
| | 1720 8 01 0.01720 |  | - | | | 1712/090 | | - | |
| | 1263 8 01 0.01263 |  | - | OPTIONAL + | | 1712/100 | | - | |
| | | | | 1712/120 | | - | | | |
| 2 | 3372/080/V40 |  | 80 | FLUID NEW | 6 | 1731 |  | - | Glass thk. Vetri sp. 8-8,7 mm (5/16") |
| 3 | 3354 |  | 80 | FLUID NEW | | 1733 |  | - | Glass thk. Vetri sp. 10-10,7 mm (3/8") |
| 4 | 3347 |  | - | | | 1737 |  | - | Glass thk. Vetri sp. 12-12,7 mm (1/2") |
| 7 | 1375 |  | - | | 8 | 1323 |  | - | |
| 9 | 88 |  | - | | | | | | |





Vetro 40 Sync

Simultaneous glass doors
Porte simultanee in vetro

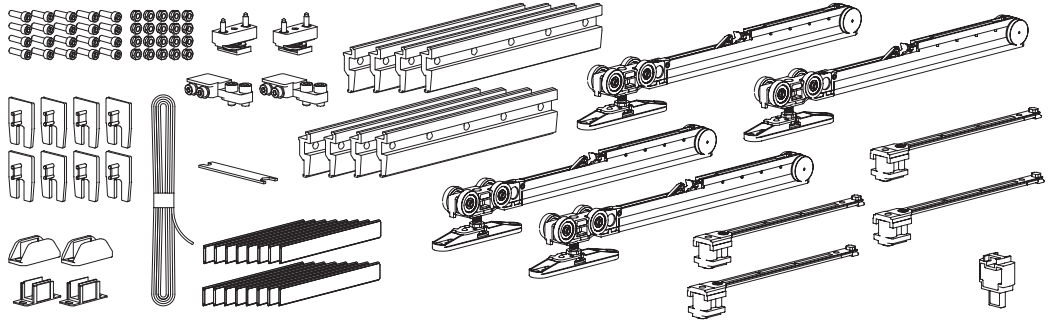
FLUID

-  N.4 Fluid dampers
-  N.4 Fermi ammortizzati Fluid
-  Ball bearings
- Cuscinetti a sfera



| OLD CODE | NEW CODE |  |  |  |  |
|----------|-----------------|--|---|---|---|
| - | K.0334.6 | 8-8,7 mm (5/16") | 80 kg | Min. 780 mm | 4x |
| - | K.0335.6 | 10-10,7 mm (3/8") | | | 4x |
| - | K.0336.6 | 12-12,7 mm (1/2") | | | 4x |

MEASUREMENTS DESCRIPTION / DESCRIZIONI MISURE

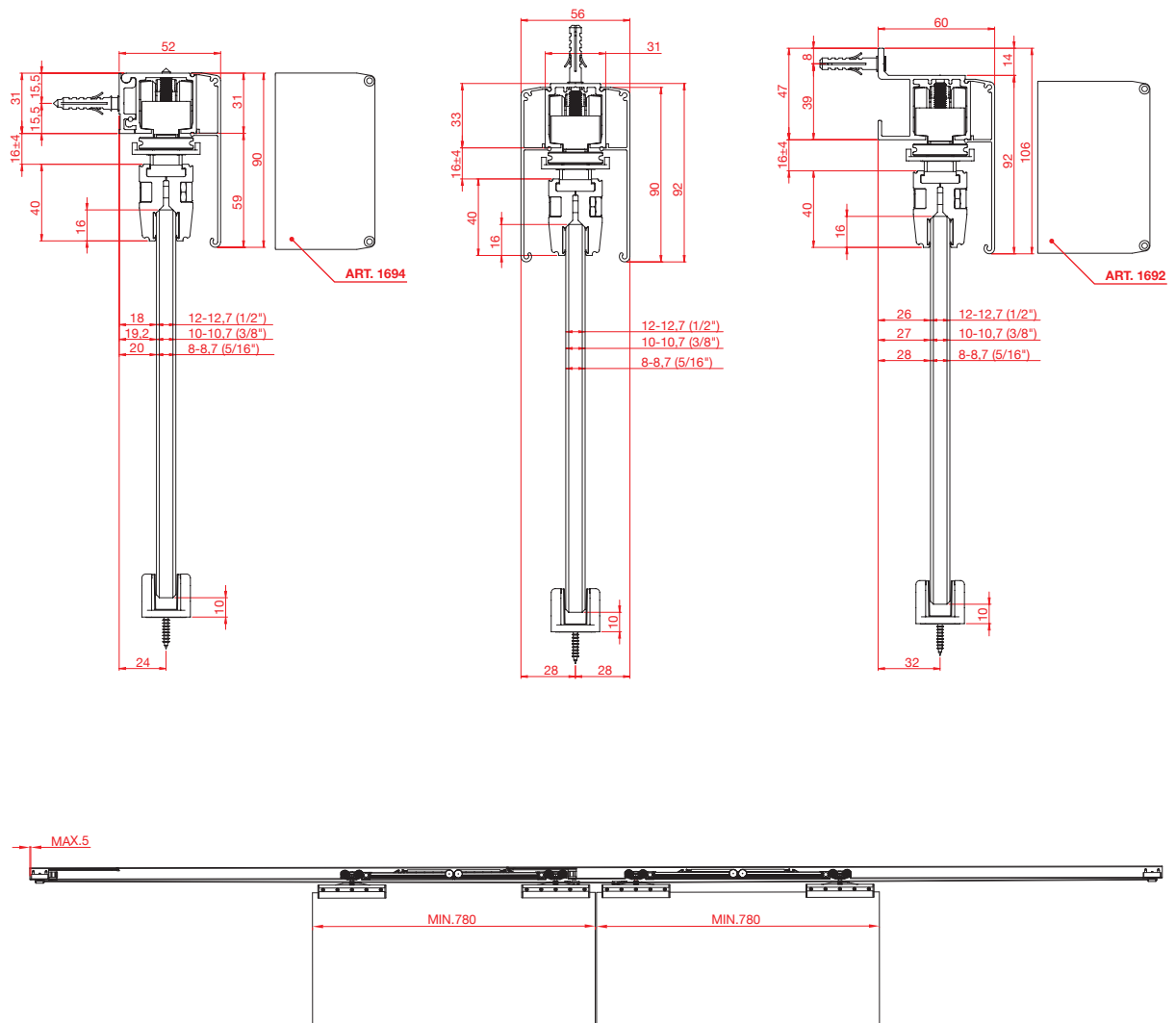

FLUID DAMPERS (OPENING AND CLOSING) / FERMI AMMORTIZZATI FLUID IN APERTURA E CHIUSURA



Vetro 70

Accessories for glass doors with safety hole and clamp height 70 mm
Accessori per porte in vetro con forature e pinza alta 70 mm

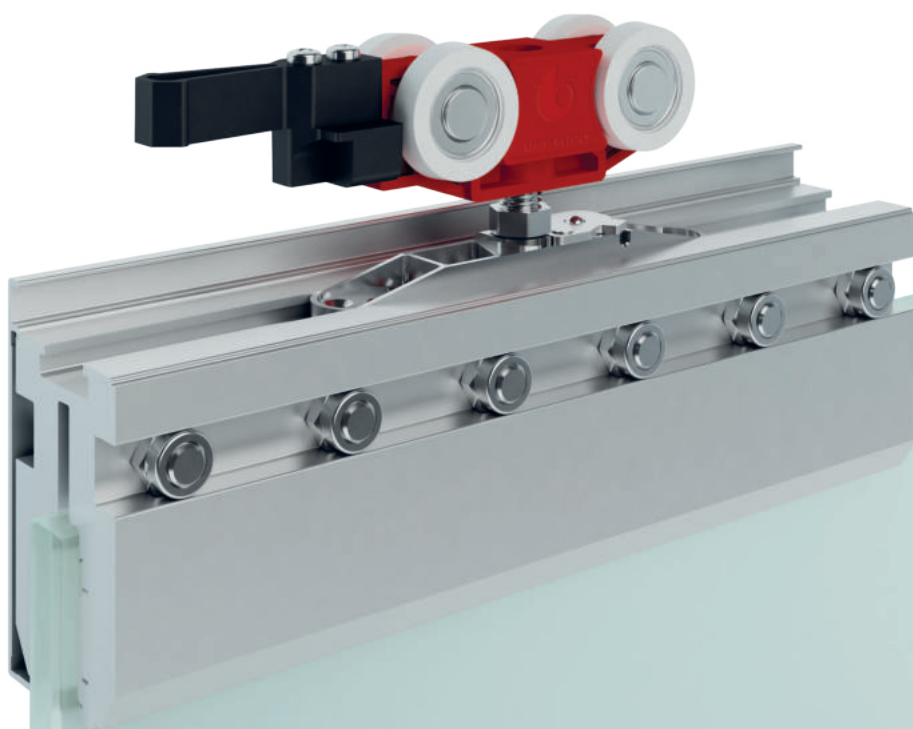



Door weight up to 250 kg

Vetro 70 is the new sliding system for glass doors, **with a maximum weight of 250 kg and a security hole.** The clamp of this system has a height of 70 mm.

Vetro 70 is suitable for glasses with thicknesses up to 12,7 mm.

Vetro 70 integrates the new sliding trolleys with **Fluid** technology: the movement turns out to be extremely light, in opening and closing, for a constantly improved user experience.

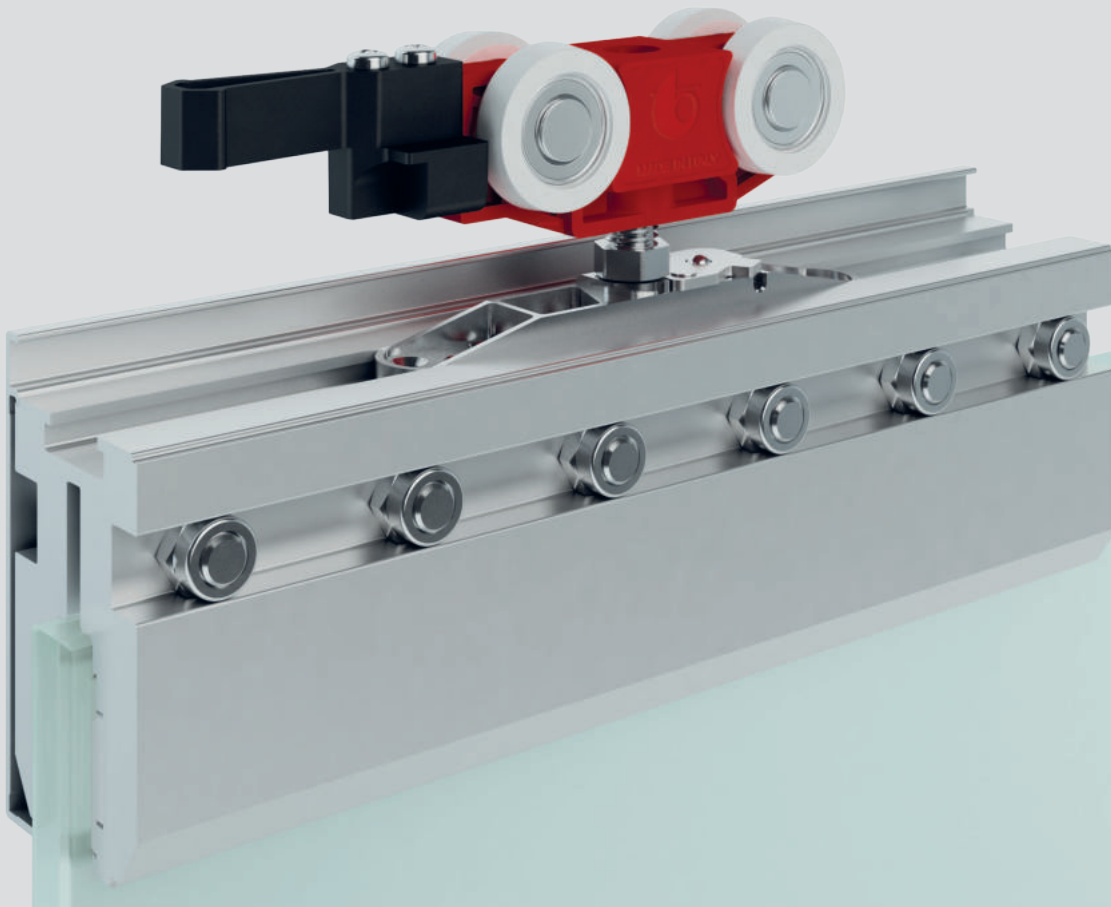



Per portate fino a 250 kg

Vetro 70 è il nuovo sistema di scorrevoli per porte in vetro, con **peso** fino ad un **massimo di 250 kg** e **foro di sicurezza.** La pinza del sistema ha un'altezza di 70 mm.

Vetro 70 è adatto a vetri con spessori fino a 12,7 mm.

Vetro 70 integra i nuovi scorrevoli con tecnologia **Fluid**: il movimento risulta così estremamente leggero, in apertura e in chiusura, per un'esperienza di utilizzo sempre migliorata.

Vetro 70 COMPLETE BOX KIT / KIT COMPLETO IN SCATOLA 

| | | |
|----------|-----------------------------|---|
| K | Complete kit / Kit completo | |
| | . | |
| | 0381 |  Glass thickness 8-8,7 mm - 5/16" Spessore vetro 8-8,7 mm - 5/16" |
| | 0382 |  Glass thickness 10-10,7 mm - 3/8" Spessore vetro 10-10,7 mm - 3/8" |
| | 0383 |  Glass thickness 12-12,7 mm - 1/2" Spessore vetro 12-12,7 mm - 1/2" |
| | . | |
| | 3 | N.2 Shock absorber - Clamp 230 mm N.2 Fermi a pinza ammortizzati - Pinza 230 mm |
| | 4 | N.2 Shock absorber - Clamp 330 mm N.2 Fermi a pinza ammortizzati - Pinza 330 mm |
| | . | |
| | | 1 180 kg |
| | | 2 250 kg |

EXAMPLE / ESEMPIO

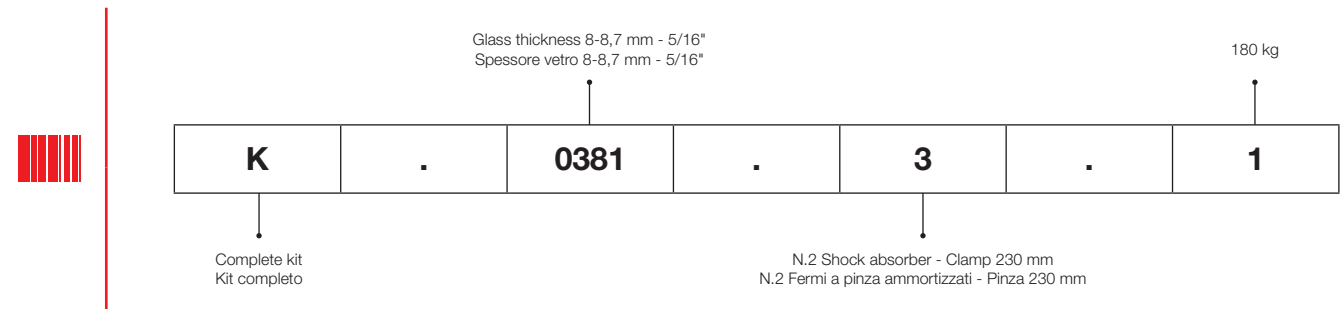

Tracks / Binari ALUMINUM FINISHES CODES / CODICI FINITURE ALLUMINIO 

| CODE / CODICE | FINISH COLOR / COLORE FINITURA | | STANDARD |
|-----------------------|--------------------------------|--|----------|
| 8 01 0.0 | 01 A | Anodized Silver / Argento | |
| 8 02 0.0 | 02 AS | Brushed Anodized Silver / Argento Spazzolato | |

Vetro 70

Accessories for glass doors with safety hole and clamp height 70 mm
 Accessori per porte in vetro con forature e pinza alta 70 mm

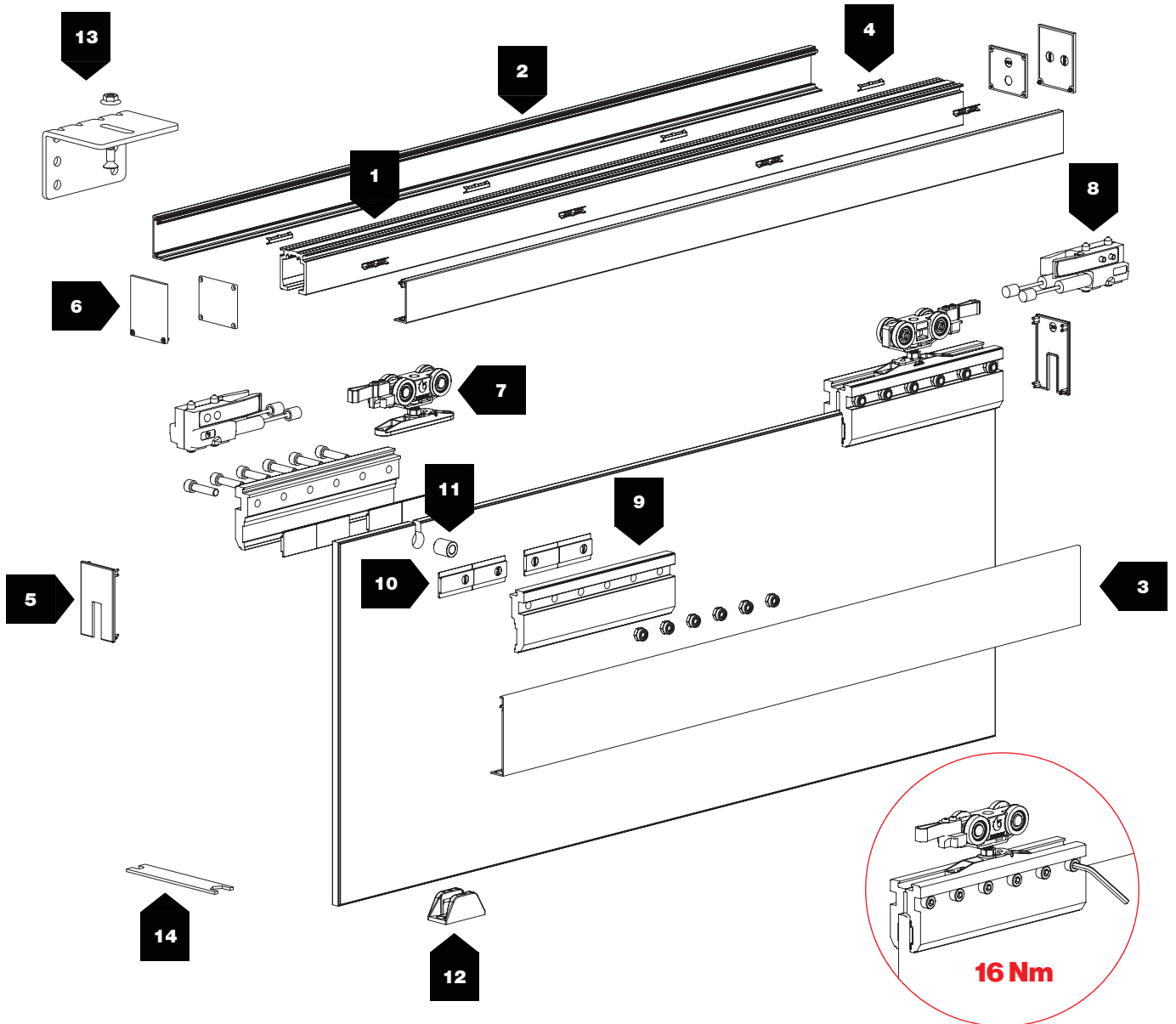

Position for trolley hooking
 Posizione per aggancio scorrevole



Position for trolley hooked
 Posizione con scorrevole agganciato

Security lockout
 Blocco di sicurezza

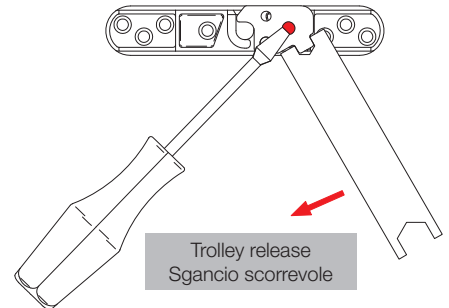

Trolley release
 Sgancio scorrevole













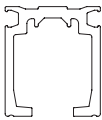
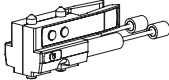

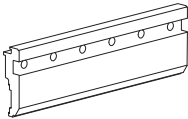

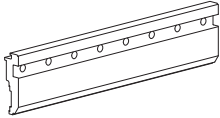
8-8,7 ÷ 12-12,7 mm

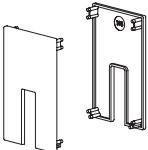

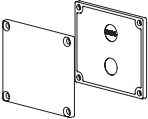
180 ÷ 250 kg

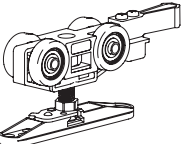

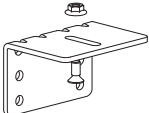
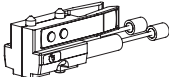
N° 1 door / N° 1 porta

| N° | Barcode | Image | kg | | N° | Barcode | Image | kg | |
|----|------------------------|---|---------|---|---|---|---|---------|---|
| 1 | 3480 8 01 0.03480 |  | — | | 8 | 3485/250 |  | 250 |  NEW |
| 2 | 3490 8 02 0.03490 |  | — | | 9 | 1746/230 |  | 180 | |
| 3 | 327 8 02 0.00327 |  | — | | | 1746/330 |  | 250 | |
| 4 | 3491 |  | — | | 10 | 1805 |  | — | Glass thk. Vetri sp. 8-8,7 mm (5/16") |
| 5 | 193/A/2 C.193/A/2 |  | — | | | 1809 |  | — | Glass thk. Vetri sp. 10-10,7 mm (3/8") |
| | | | | | | 1792 |  | — | Glass thk. Vetri sp. 12-12,7 mm (1/2") |
| 6 | 3494/A/2 C.3494/A/2 |  | — | | 11 |  | — | | |
| | | | | 3496/A/2 C.3496/A/2 |  | — | | 12 | 1488 |
| 7 | 1660 |  | 180÷250 |  NEW | 13 | 163/DV |  | 180÷250 | |
| 8 | 3485/180 |  | 180 |  NEW | 14 | 1029 |  | — | |



Vetro 70

Accessories for glass doors with safety hole and clamp height 70 mm
 Accessori per porte in vetro con forature e pinza alta 70 mm

FLUID

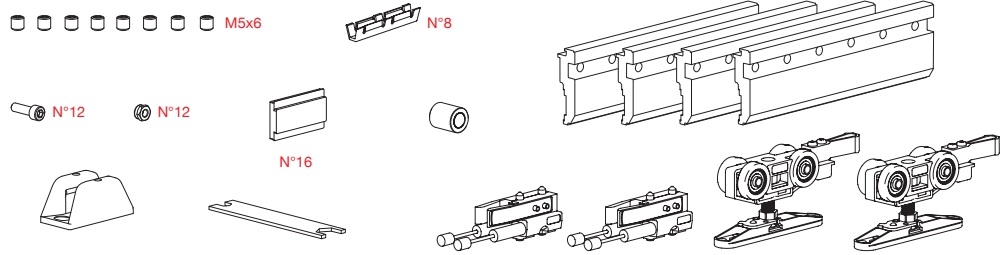
-  N.2 Shock absorbers
N.2 Fermi a pinza ammortizzati
-  Ball bearings
Cuscinetti a sfera
-  Clamp - 230 mm
Pinza da 230 mm





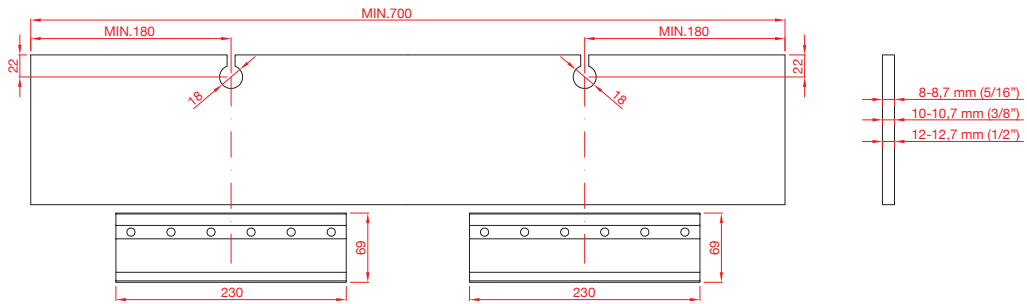

| OLD CODE | NEW CODE |  |  |  |
|--------------|------------|--|---|---|
| 1746/1167/08 | K.0381.3.1 | 180 kg | 8-8,7 mm (5/16") | 4x |
| 1746/1167/10 | K.0382.3.1 | | 10-10,7 mm (3/8") | 4x |
| 1746/1167/12 | K.0383.3.1 | | 12-12,7 mm (1/2") | 4x |

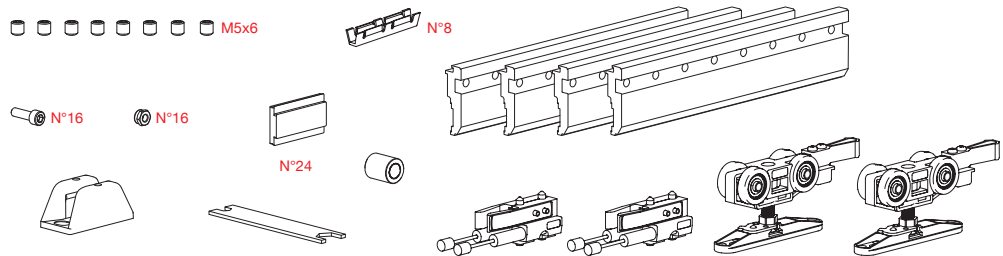

FLUID

-  N.2 Shock absorbers
N.2 Fermi a pinza ammortizzati
-  Ball bearings
Cuscinetti a sfera
-  Clamp - 330 mm
Pinza da 330 mm



| OLD CODE | NEW CODE |  |  |  |
|-------------|------------|--|---|---|
| 1746/209/08 | K.0381.4.2 | 250 kg | 8-8,7 mm (5/16") | 4x |
| 1746/209/10 | K.0382.4.2 | | 10-10,7 mm (3/8") | 4x |
| 1746/209/12 | K.0383.4.2 | | 12-12,7 mm (1/2") | 4x |

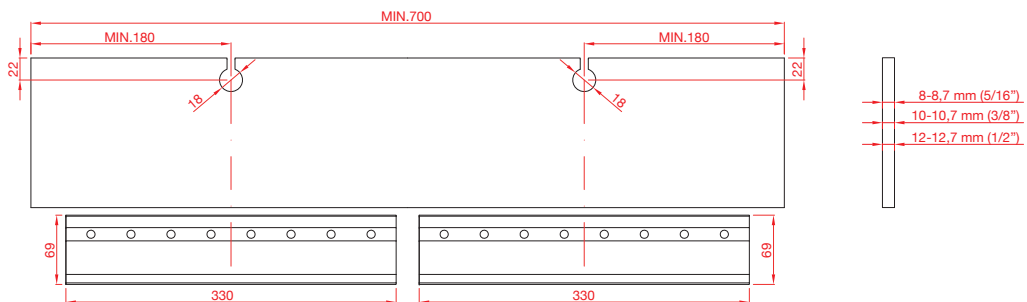

MEASUREMENTS DESCRIPTION / DESCRIZIONI MISURE

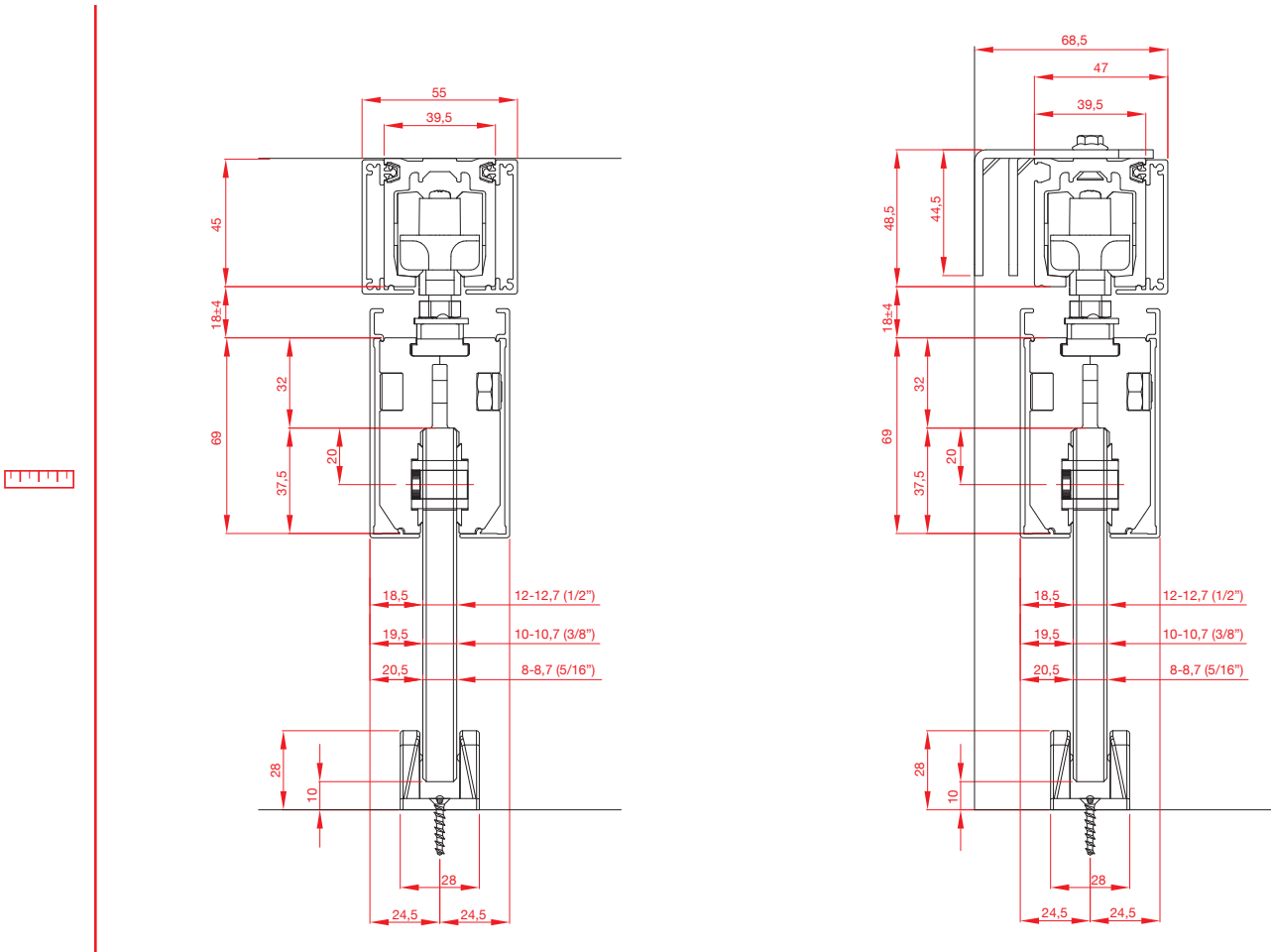



Vetro 74

Accessories for glass doors with safety hole and clamp height 74 mm
Accessori per porte in vetro con forature e pinza alta 74 mm

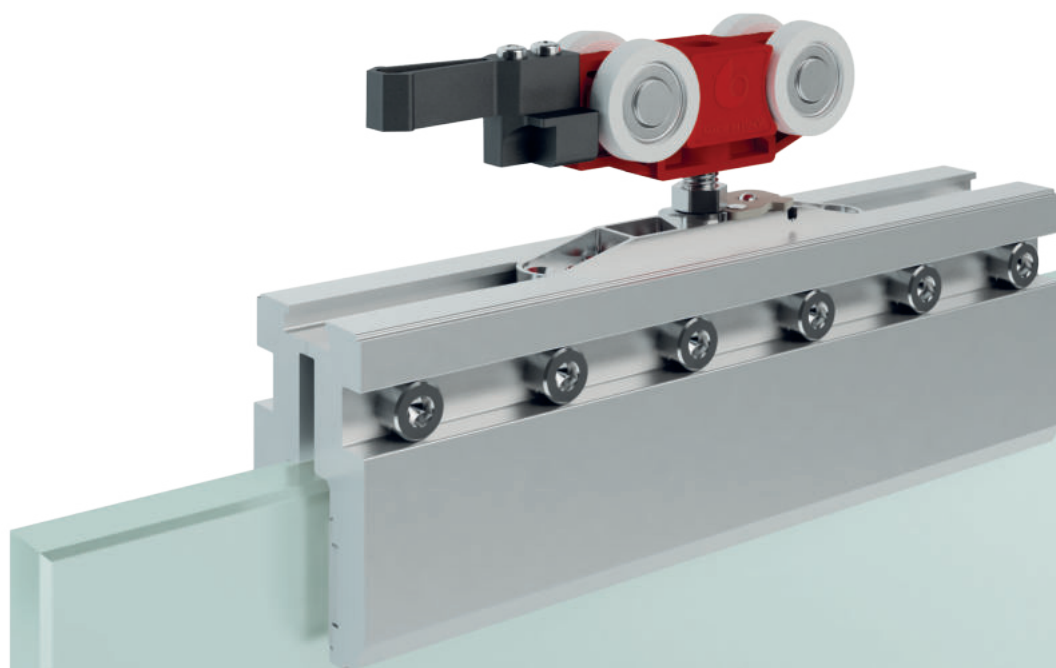



Door weight up to 250 kg

Vetro 74 is the new system of sliding system for glass doors, with a **weight up to a maximum of 250 kg and a security hole**. The clamp of this system has a height of 74 mm.

Vetro 74 is suitable for glass with thicknesses up to 19 mm.

Vetro 74 integrates the new sliding trolleys with **Fluid** technology: the **movement** turns out to be **extremely light**, in opening and closing, for a constantly improved user experience.

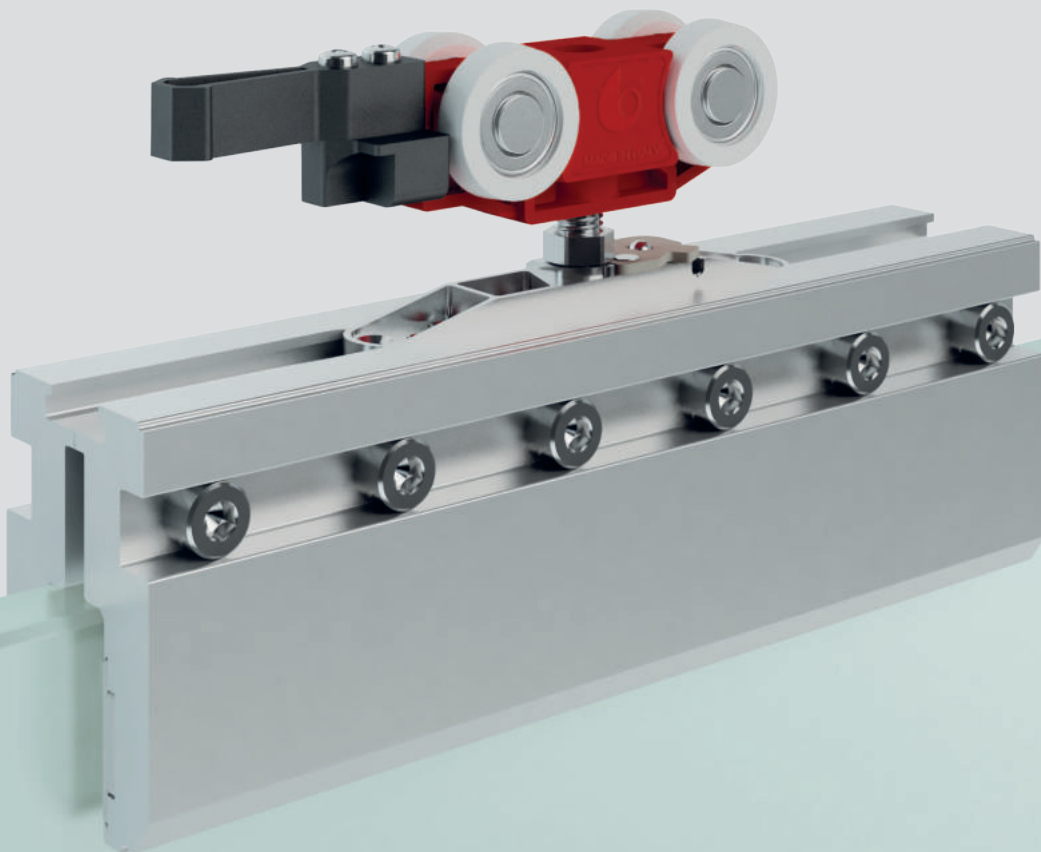





Per portate fino a 250 kg

Vetro 74 è il nuovo sistema di scorrevoli per porte in vetro, con **peso** fino ad un **massimo di 250 kg e foro di sicurezza**. La pinza del sistema ha un'altezza di 74 mm.

Vetro 74 è adatto a vetri con spessori fino a 19 mm.

Vetro 74 integra i nuovi scorrevoli con tecnologia **Fluid**: il **movimento** risulta così **estremamente leggero**, in apertura e in chiusura, per un'esperienza di utilizzo sempre migliorata.

| Vetro 74 | | COMPLETE BOX KIT / KIT COMPLETO IN SCATOLA | |  |
|-----------------|-----------------------------|---|---|---|
| K | Complete kit / Kit completo | | | |
| | | | | |
| | 0391 |  | Glass thickness 15-15,7 mm - 5/8" Spessore vetro 15-15,7 mm - 5/8" | |
| | 0392 |  | Glass thickness 16 mm Spessore vetro 16 mm | |
| | 0393 |  | Glass thickness 17 mm Spessore vetro 17 mm | |
| | 0394 |  | Glass thickness 19-19,7 mm - 3/4" Spessore vetro 19-19,7 mm - 3/4" | |
| | | | | |
| | | 3 | N.2 Shock absorber - Clamp 230 mm N.2 Fermi a pinza ammortizzati - Pinza 230 mm | |
| | | 4 | N.2 Shock absorber - Clamp 330 mm N.2 Fermi a pinza ammortizzati - Pinza 330 mm | |
| | | | | |
| | | | | 1 180 kg |
| | | | | 2 250 kg |

EXAMPLE / ESEMPIO

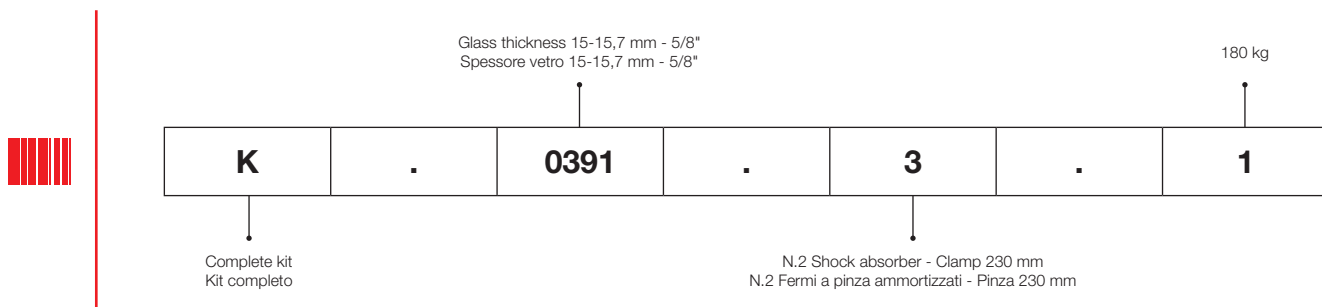

| Tracks / Binari | | ALUMINUM FINISHES CODES / CODICI FINITURE ALLUMINIO | |  |
|------------------------|---|---|--|---|
| CODE / CODICE | FINISH COLOR / COLORE FINITURA | | | STANDARD |
| 8 01 0.0 |  | 01 A | Anodized Silver / Argento | |
| 8 02 0.0 |  | 02 AS | Brushed Anodized Silver / Argento Spazzolato | |

Vetro 74

Accessories for glass doors with safety hole and clamp height 74 mm
 Accessori per porte in vetro con forature e pinza alta 74 mm

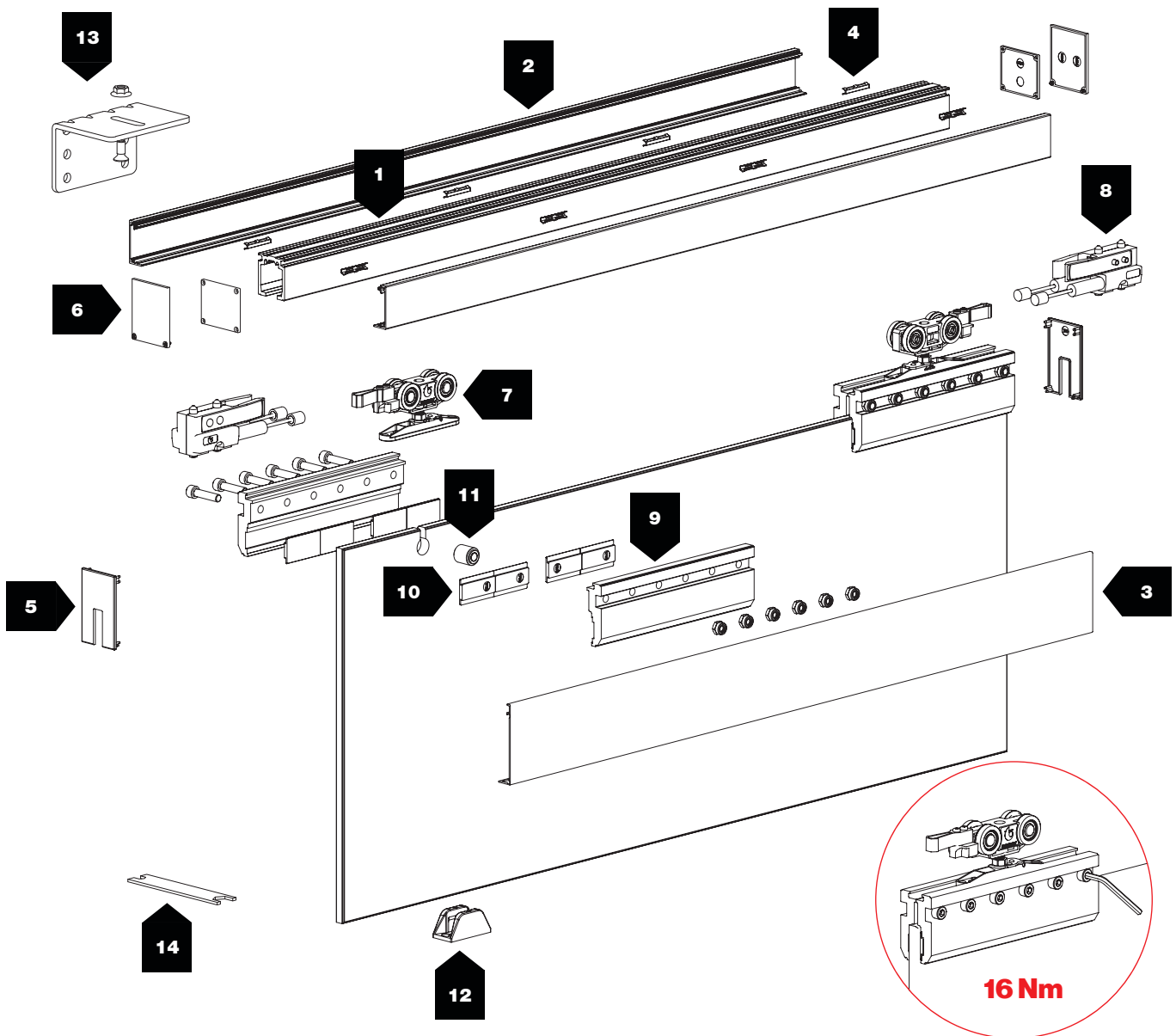

Position for trolley hooking
 Posizione per aggancio scorrevole

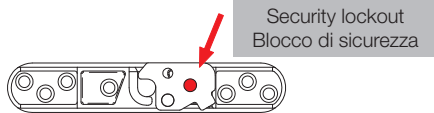

Position for trolley hooked
 Posizione con scorrevole agganciato

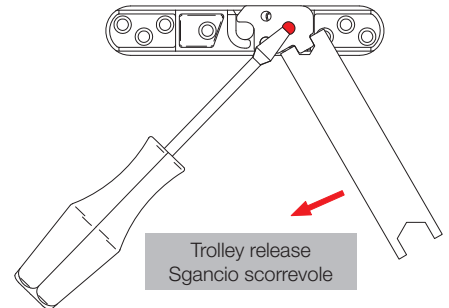

Trolley release
 Sgancio scorrevole













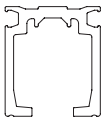
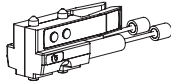

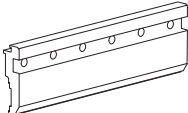

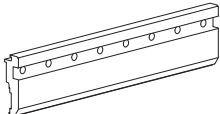

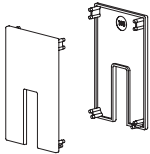

15-15,7 ÷ 19-19,7 mm

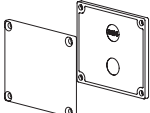

180 ÷ 250 kg

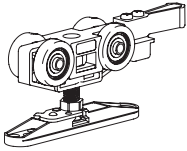

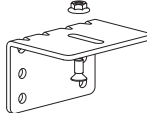
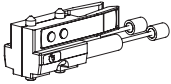
N° 1 door / N° 1 porta

| N° | Barcode | | kg | | N° | Barcode | | kg | |
|----|------------------------|---|---------|---|----|----------|---|---------|---|
| 1 | 3480 8 01 0.03480 |  | — | | 8 | 3485/250 |  | 250 |  NEW |
| 2 | 3490 8 02 0.03490 |  | — | | 9 | 1746/230 |  | 180 | |
| 3 | 329 8 02 0.00329 |  | — | | | 1746/330 |  | 250 | |
| 4 | 3491 |  | — | | 10 | 1805 |  | — | Glass thk. Vetri sp. 15-15,7 mm (5/8") |
| | | | — | | | 1807 |  | — | Glass thk. Vetri sp. 16 mm |
| 5 | 195/A/2 C.195/A/2 |  | — | | | 1809 |  | — | Glass thk. Vetri sp. 17 mm |
| | | | — | | | 1792 |  | — | Glass thk. Vetri sp. 19-19,7 mm (3/4") |
| 6 | 3494/A/2 C.3494/A/2 |  | — | | 11 | 1796 |  | — | |
| | 3496/A/2 C.3496/A/2 |  | — | | 12 | 1498 |  | 180÷250 | Glass thk. Vetri sp. 15-15,7 mm ÷ 19-19,7 mm (5/8"÷3/4") |
| 7 | 1660 |  | 180÷250 |  NEW | 13 | 163/DV |  | 180÷250 | |
| 8 | 3485/180 |  | 180 |  NEW | 14 | 1029 |  | — | |



Vetro 74

Accessories for glass doors with safety hole and clamp height 74 mm
 Accessori per porte in vetro con forature e pinza alta 74 mm

FLUID

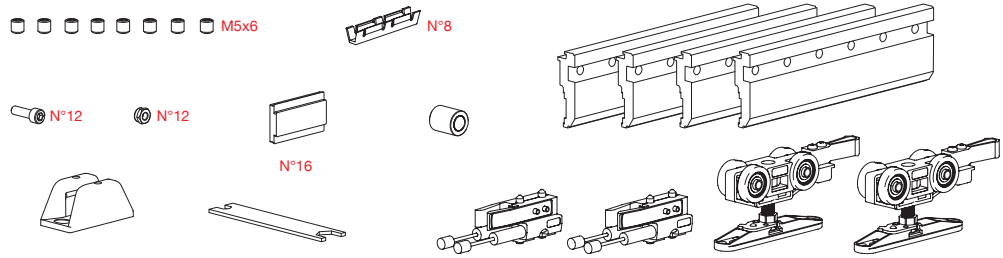
-  N.2 Shock absorbers
N.2 Fermi a pinza ammortizzati
-  Ball bearings
Cuscinetti a sfera
-  Clamp - 230 mm
Pinza da 230 mm





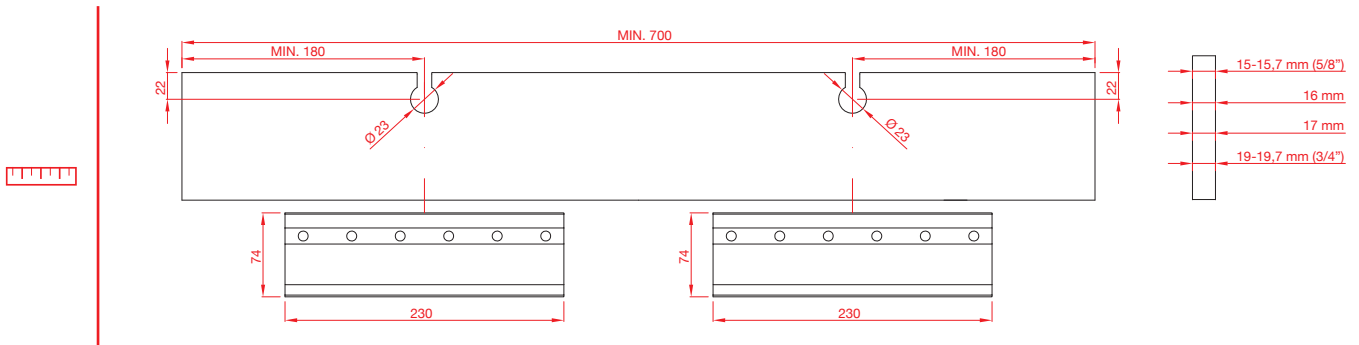

| OLD CODE | NEW CODE |  |  |  |
|--------------|------------|--|---|---|
| 1766/1167/15 | K.0391.3.1 | 180 kg | 15-15,7 mm (5/8") | 4x |
| 1766/1167/16 | K.0392.3.1 | | 16 mm | 4x |
| 1766/1167/17 | K.0393.3.1 | | 17 mm | 4x |
| 1766/1167/19 | K.0394.3.1 | | 19-19,7 mm (3/4") | 4x |

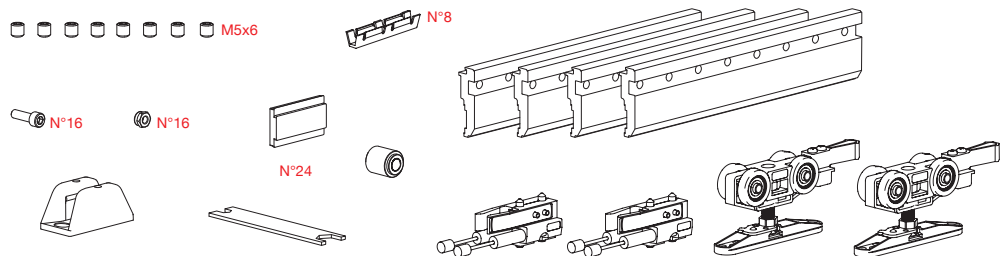

FLUID

-  N.2 Shock absorbers
N.2 Fermi a pinza ammortizzati
-  Ball bearings
Cuscinetti a sfera
-  Clamp - 330 mm
Pinza da 330 mm



| OLD CODE | NEW CODE |  |  |  |
|-------------|------------|--|---|---|
| 1766/209/15 | K.0391.4.2 | 250 kg | 15-15,7 mm (5/8") | 4x |
| 1766/209/16 | K.0392.4.2 | | 16 mm | 4x |
| 1766/209/17 | K.0393.4.2 | | 17 mm | 4x |
| 1766/209/19 | K.0394.4.2 | | 19-19,7 mm (3/4") | 4x |

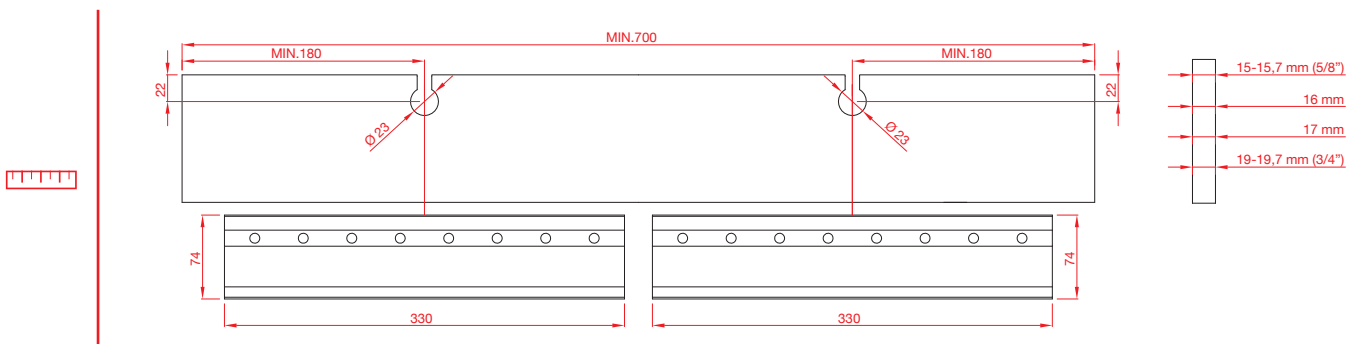

MEASUREMENTS DESCRIPTION / DESCRIZIONI MISURE

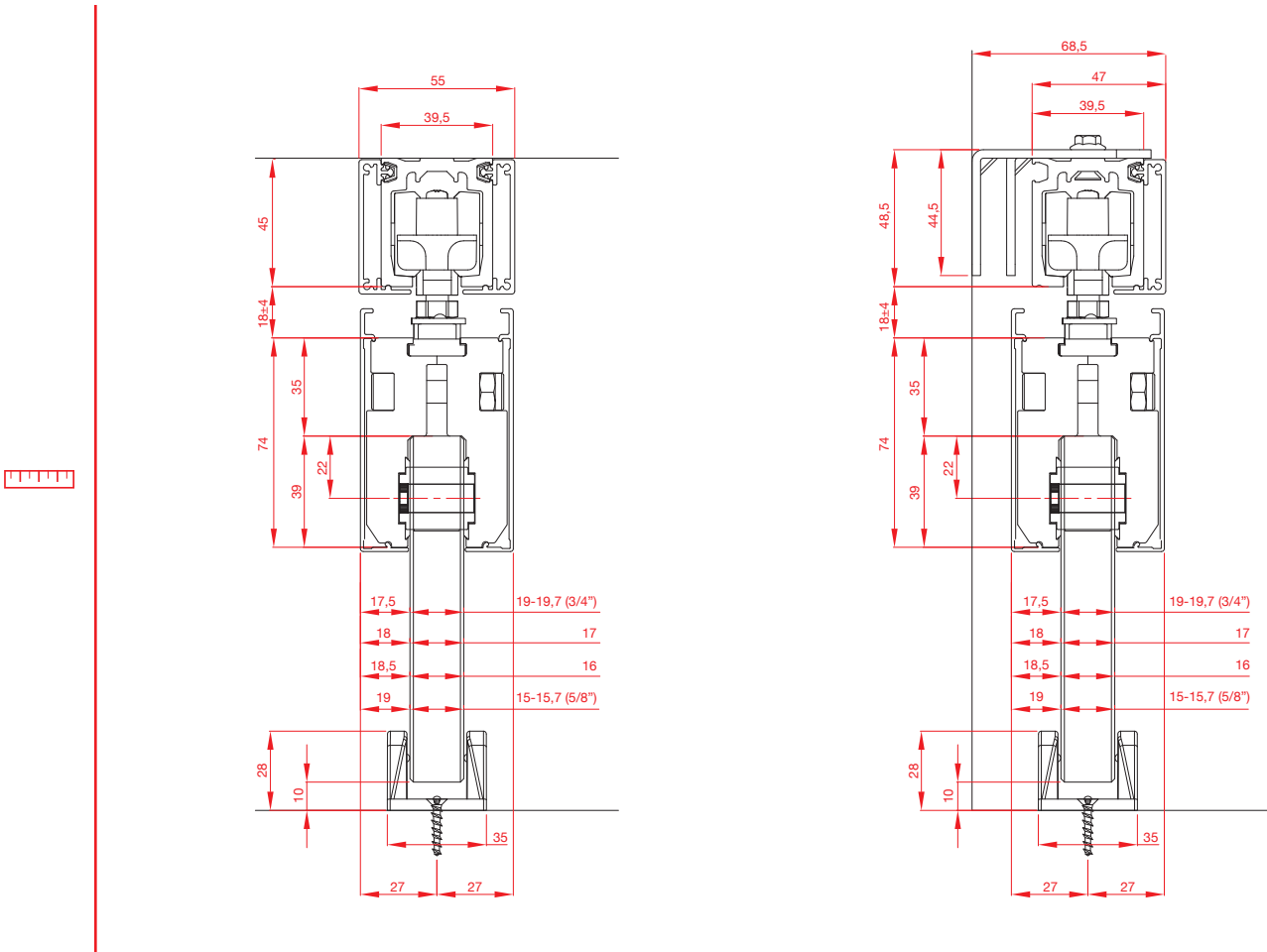



Vetro Fisso

Systems for fixed glass panels
Sistemi per vetri fissi

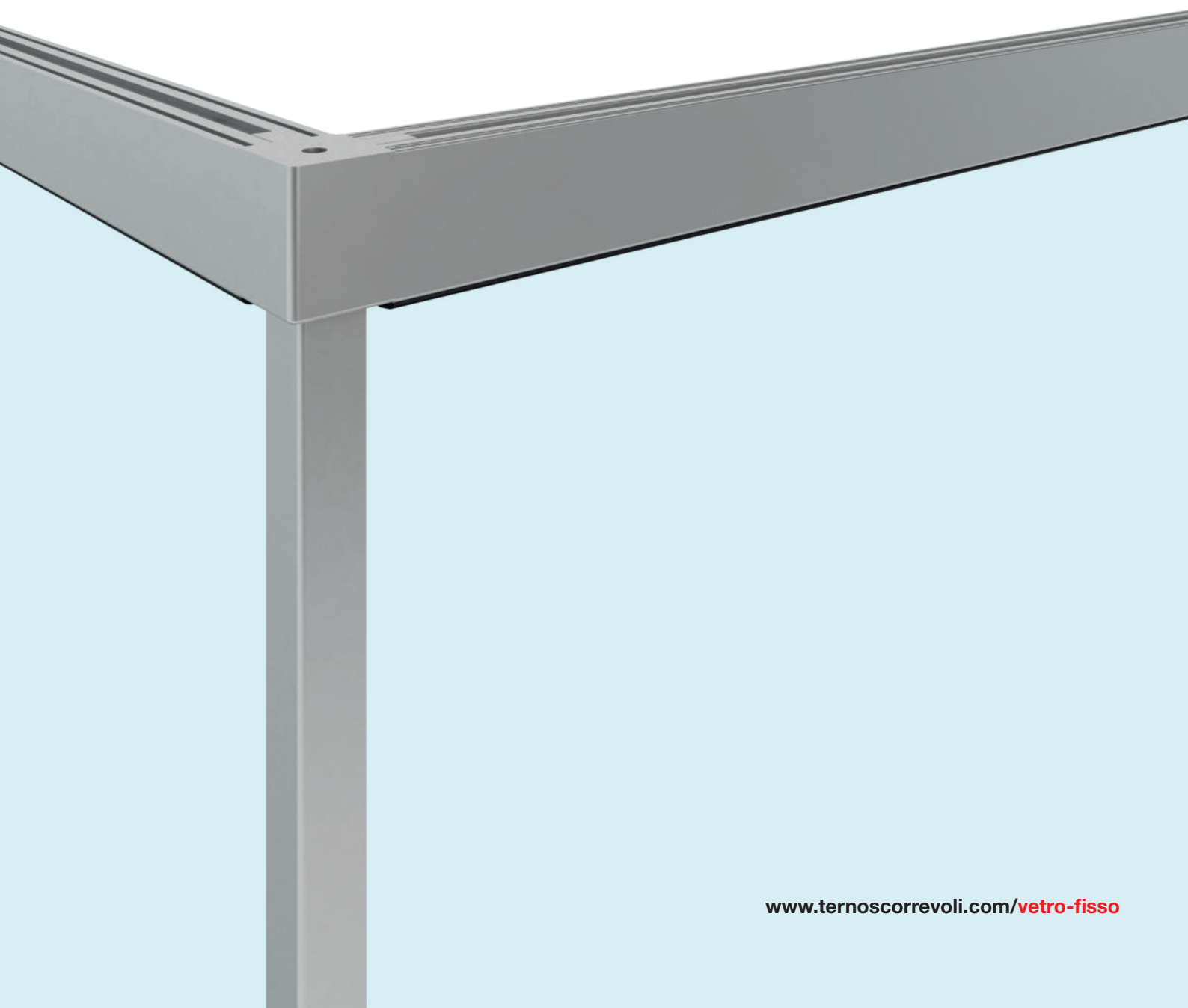



PROFILE HEIGHT 27 mm / ALTEZZA PROFILO 27 mm

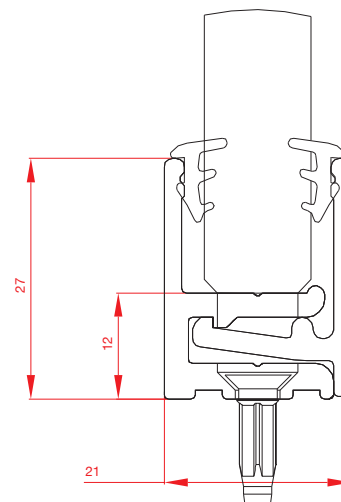
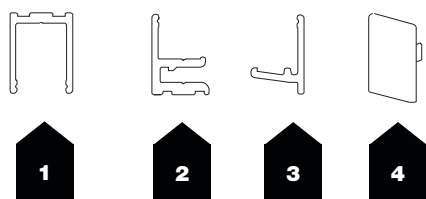

PROFILE HEIGHT 30 mm / ALTEZZA PROFILO 30 mm

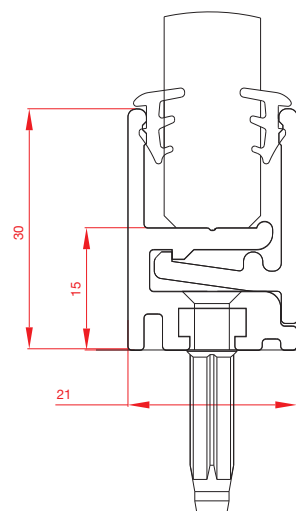
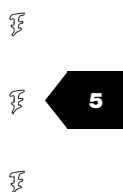
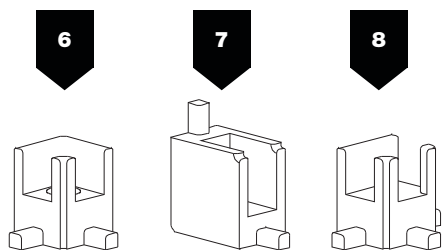
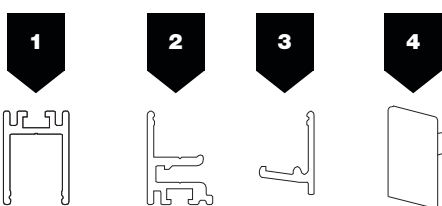

| N° | Barcode | Image | kg | | N° | Barcode | Image | kg | |
|----|------------------------|-------|----|---|----|---------------------|------------------|----|---|
| 1 | 1772 8 01 0.01772 | | — | Profile height Altezza profilo 27 mm | 5 | 328 8 21 0.00328 | | — | Glass thk. Vetri sp. 8-8,7 mm (5/16") |
| | 1773 8 01 0.01773 | | — | Profile height Altezza profilo 30 mm | | 326 8 21 0.00326 | | — | Glass thk. Vetri sp. 10-10,7 mm (3/8") |
| 2 | 1774 8 01 2.01774 | | — | Profile height Altezza profilo 27 mm | | 324 8 21 0.00324 | | — | Glass thk. Vetri sp. 12-12,7 mm (1/2") |
| | 1775 8 01 2.01775 | | — | Profile height Altezza profilo 30 mm | | 6 | 1777 S.1777/A | | — |
| 3 | 1776 8 01 0.01776 | | — | | | | 1779 S.1779/A | | — |
| 4 | 1784/A/2 C.1784/A/2 | | — | Profile height Altezza profilo 27 mm | 8 | 1778 S.1778/A | | — | Profile height Altezza profilo 30 mm |
| | 1794/A/2 C.1794/A/2 | | — | Profile height Altezza profilo 30 mm | | | | | |

Tracks / Binari

ALUMINUM FINISHES CODES / CODICI FINITURE ALLUMINIO



CODE / CODICE

FINISH COLOR / COLORE FINITURA

8 01 0.0

01 A

Anodized Silver / Argento

STANDARD

Tracks / Binari

PLASTIC FINISHES CODES / CODICI FINITURE PLASTICA



CODE / CODICE

FINISH COLOR / COLORE FINITURA

8 20 0.0

20

Rigid Transparent / Trasparente Rigido

8 21 0.0

21

Soft Transparent / Trasparente Morbido

STANDARD

MEASUREMENTS DESCRIPTION - PROFILE HEIGHT 27 mm / DESCRIZIONI MISURE - ALTEZZA PROFILO 27 mm

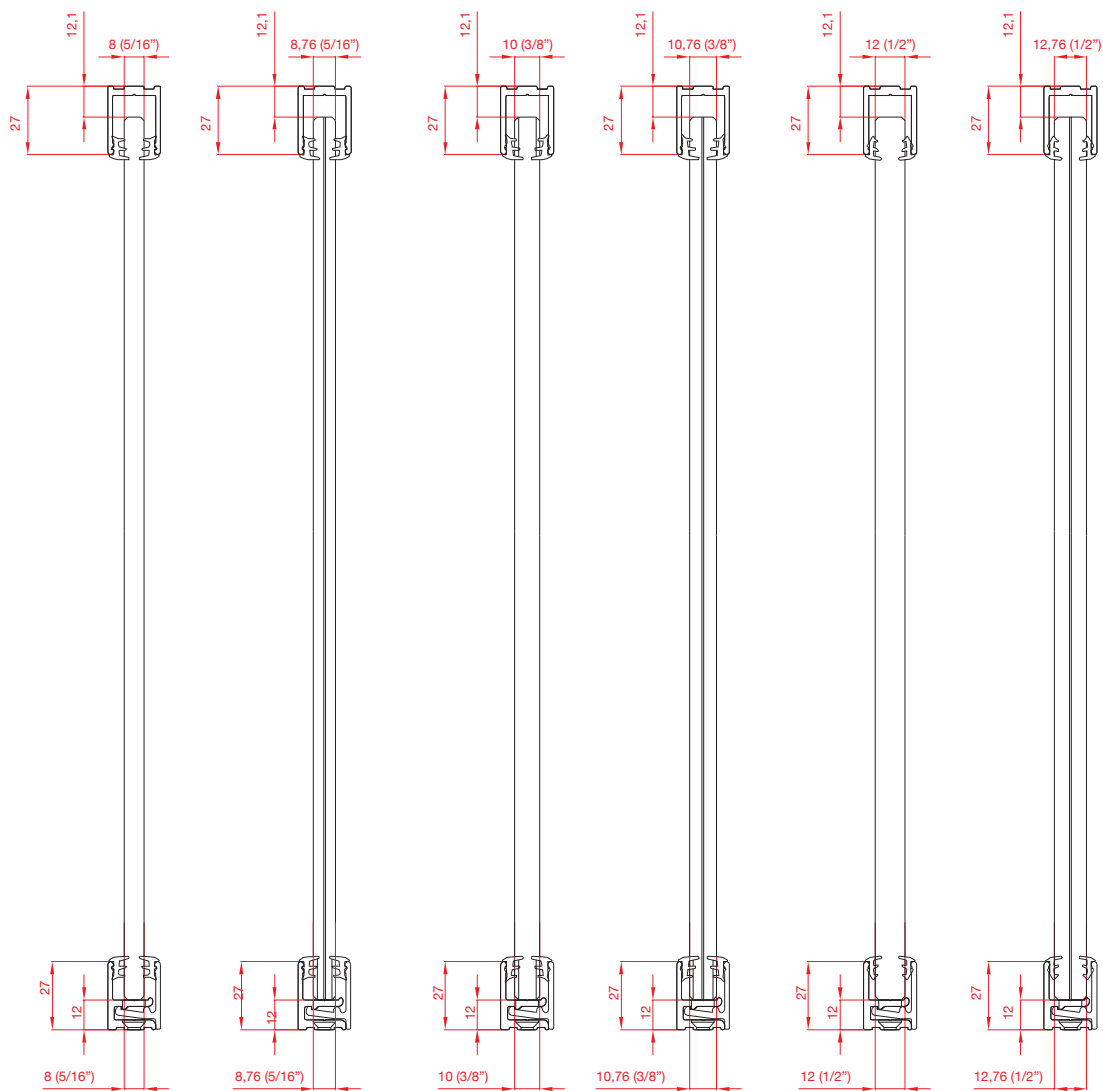

MEASUREMENTS DESCRIPTION - PROFILE HEIGHT 30 mm / DESCRIZIONI MISURE - ALTEZZA PROFILO 30 mm

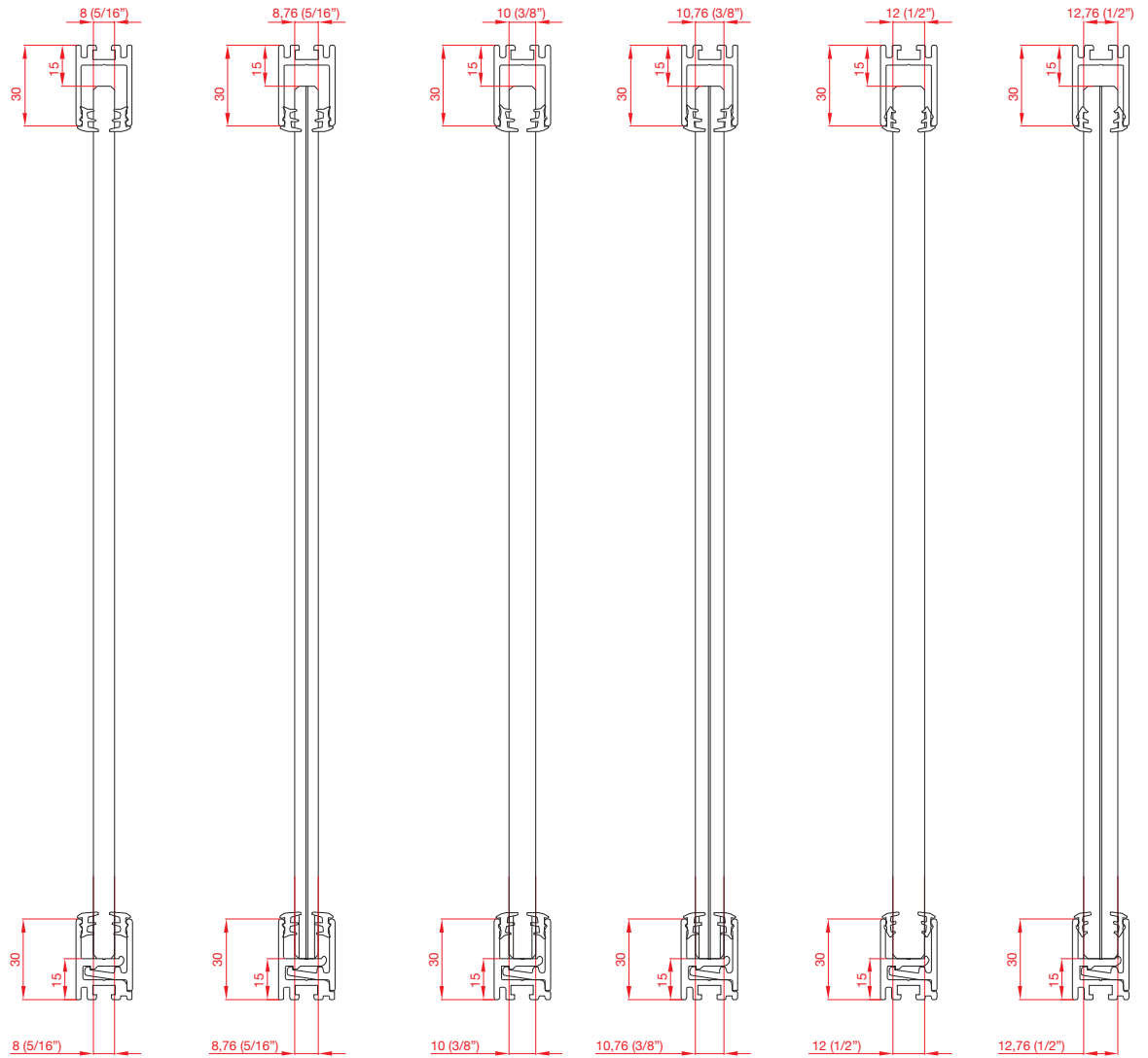

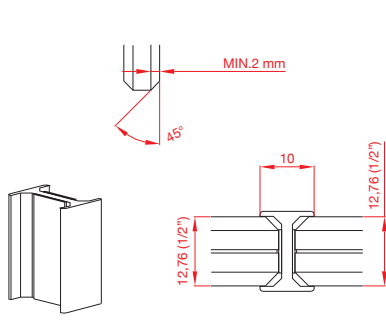

ART. 1741
 8 20 0.01741

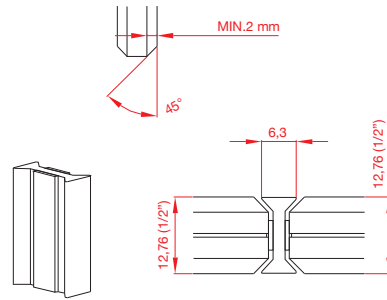

ART. 1781
 8 20 0.01781

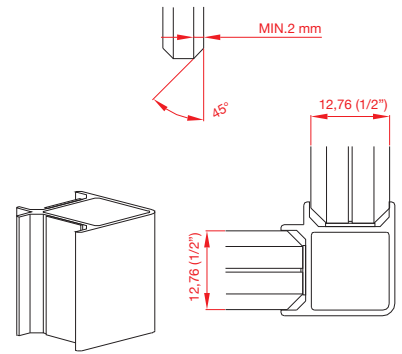

ART. 1745
 8 20 0.01745

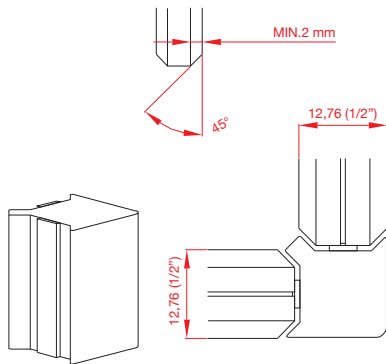

ART. 1785
 8 20 0.01785

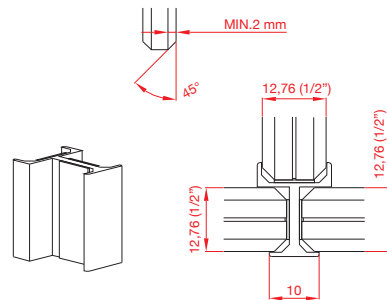

ART. 1743
 8 20 0.01743

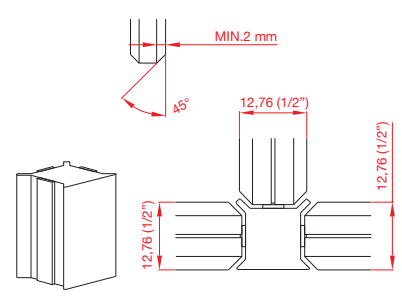

ART. 1783
 8 20 0.01783

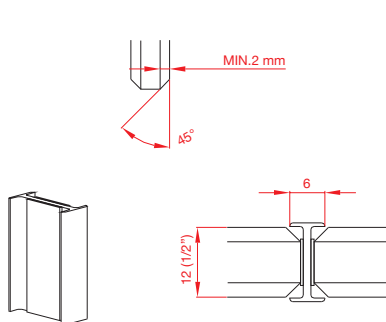
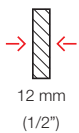

ART. 1747
 8 20 0.01747

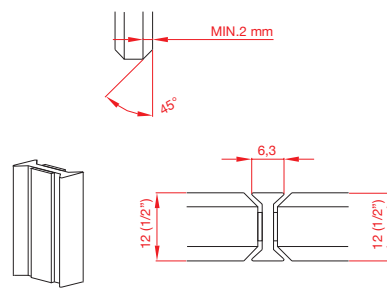

ART. 1787
 8 20 0.01787

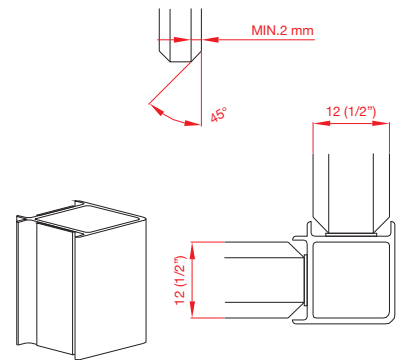

ART. 1749
 8 20 0.01749

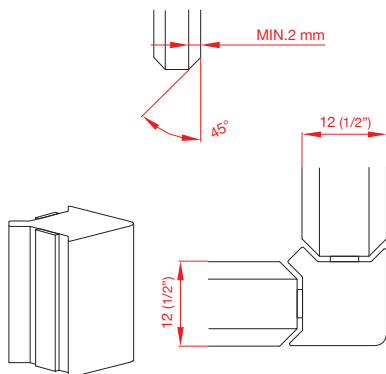

ART. 1789
 8 20 0.01789

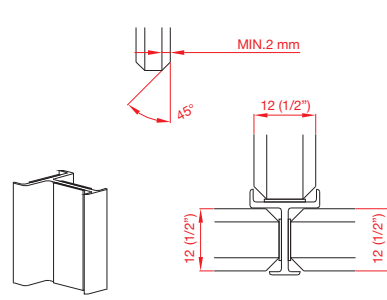

ART. 1748
 8 20 0.01748

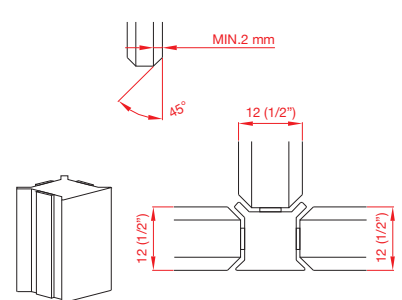

ART. 1788
 8 20 0.01788

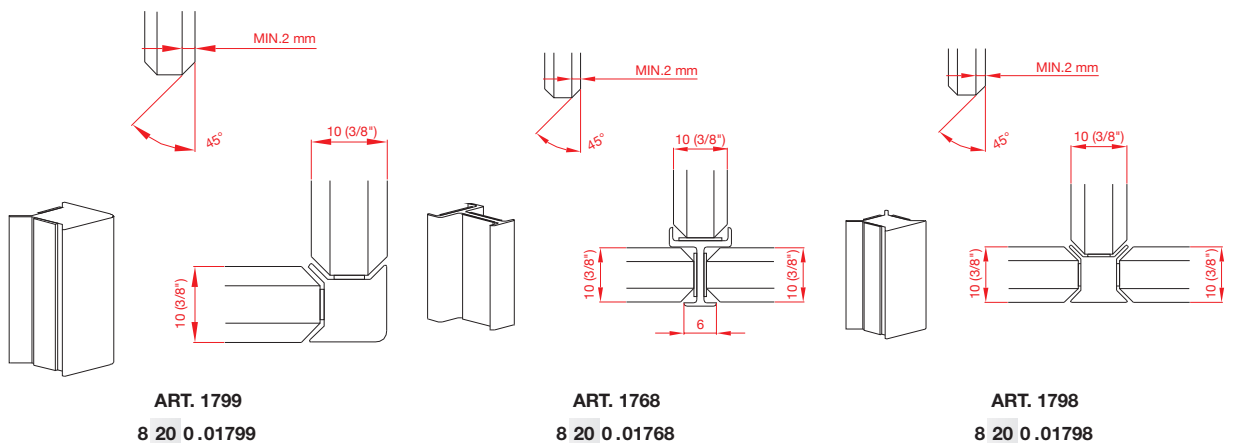
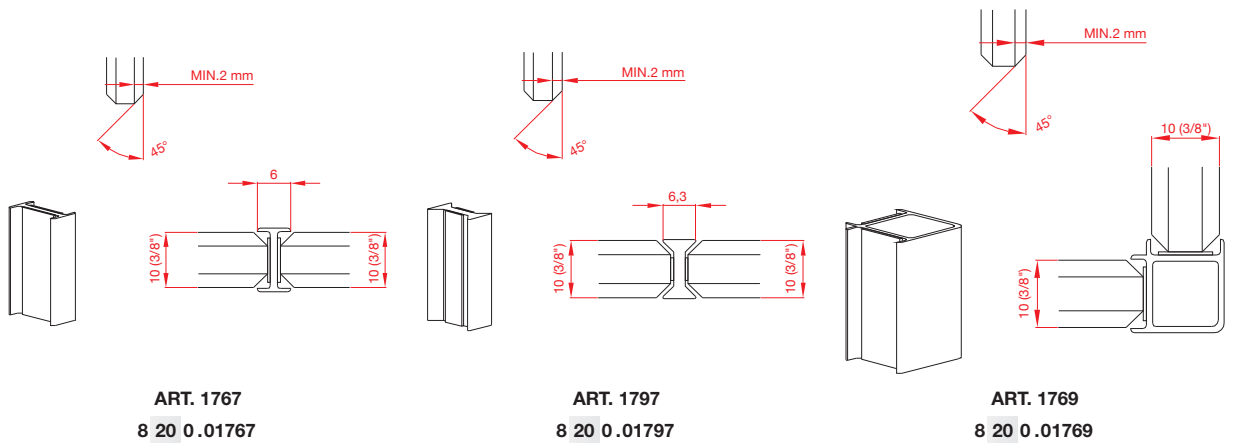
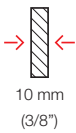
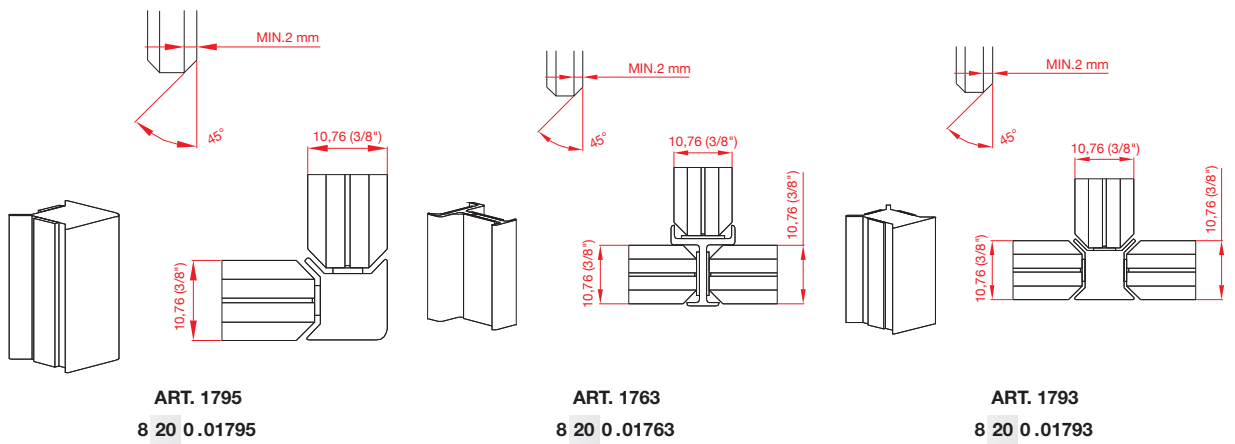
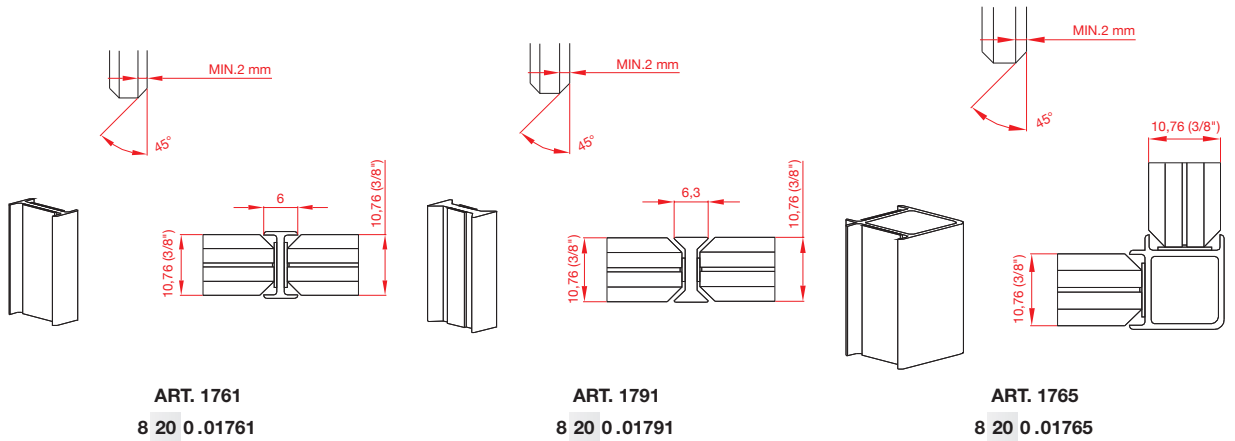

JOINTS ASSEMBLING / MONTAGGIO GIUNZIONI

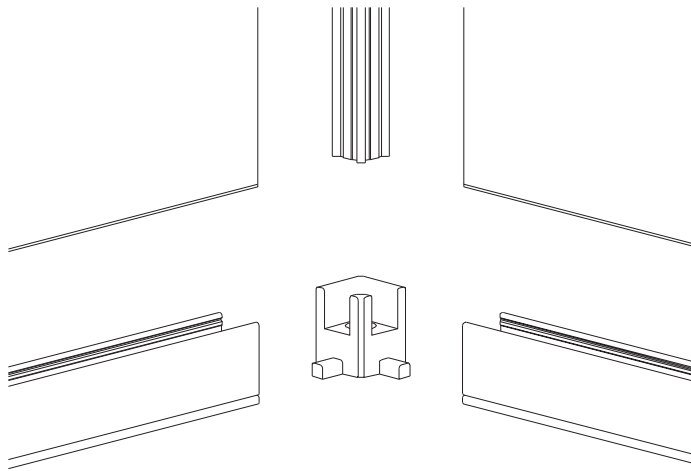

ART. 1777

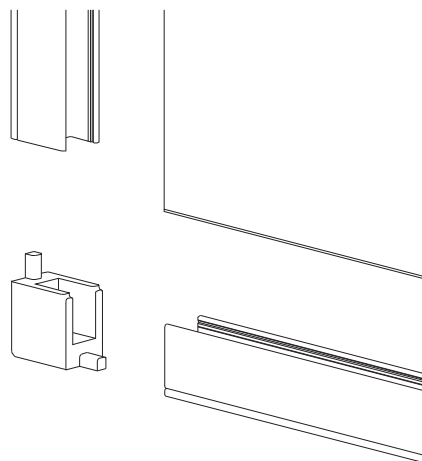
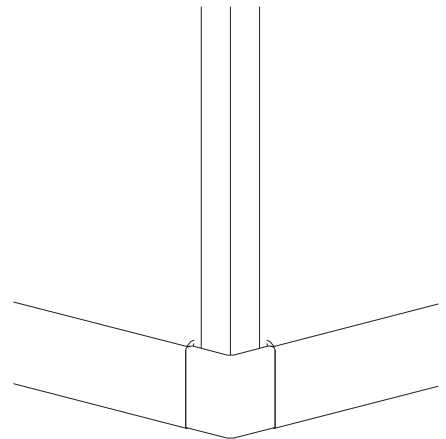

ART. 1779

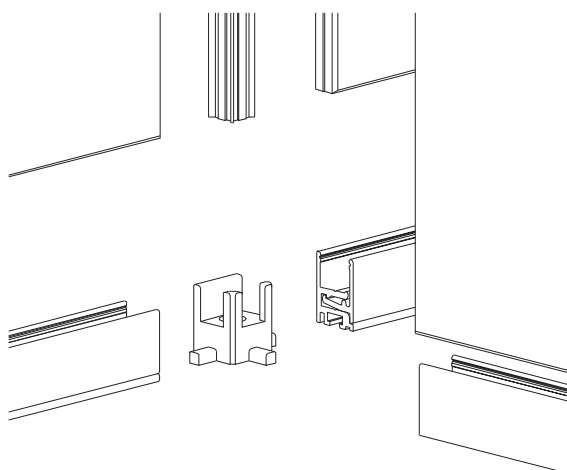
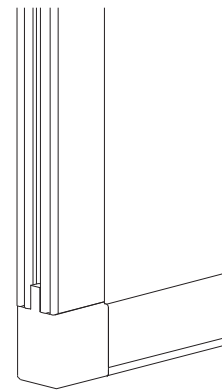

ART. 1778

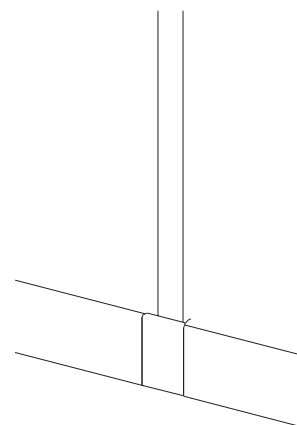



Terno Scorrevoli S.p.A.

**Via Ravenna, 4 - 20814 Varedo (MB) ITALY
Phone +39 0362 543001 - Fax +39 0362 582290**

**terno@ternoscorrevoli.com
www.ternoscorrevoli.com**