

Scorrevoli per antine in legno, alluminio o vetro



Slides for small wood, aluminium or glass panels
Rails coulissants pour petites portes en bois, aluminium ou verre
Schiebetüren mit Holz- Aluminium- oder Glastüren
Correderas para puertas de madera, aluminio o vidrio



Sistema di scorrevoli regolabili per ante in legno, alluminio o vetro.

Slides for small wood, aluminium or glass panels.

Rails coulissants pour petites portes en bois, aluminium ou verre.

Schiebetüren mit Holz- Aluminium- oder Glastüren.

Correderas para puertas de madera, aluminio o vidrio.

Schemi di foratura per ante in legno, vetro, telai in legno e alluminio

Illustrations of drilling for doors in wood, glass, structures in wood and aluminium
Schemas de perçage pour portes en bois, verre, châssis en bois, aluminium
Bohrungsschema für taüren aus Holz, Glas, mit Holzrahmen, aluminium
Esquemas de perforacion para puertas de madera, cristal, marcos de madera aluminio



SCEGLIERE FORATURA "A" o "B"
Choose drilling "A" or "B"
Choisir perçage "A" ou "B"
Die bohrung "A" oder "B" wählen
Seleccionar la perforacion "A" o "B"

Telaio/Frame Min. 35 mm. per/for art.
404-406-408-486-405-407
Telaio/Frame Min. 30 mm. per/for art.
352-354-356-358-355-357

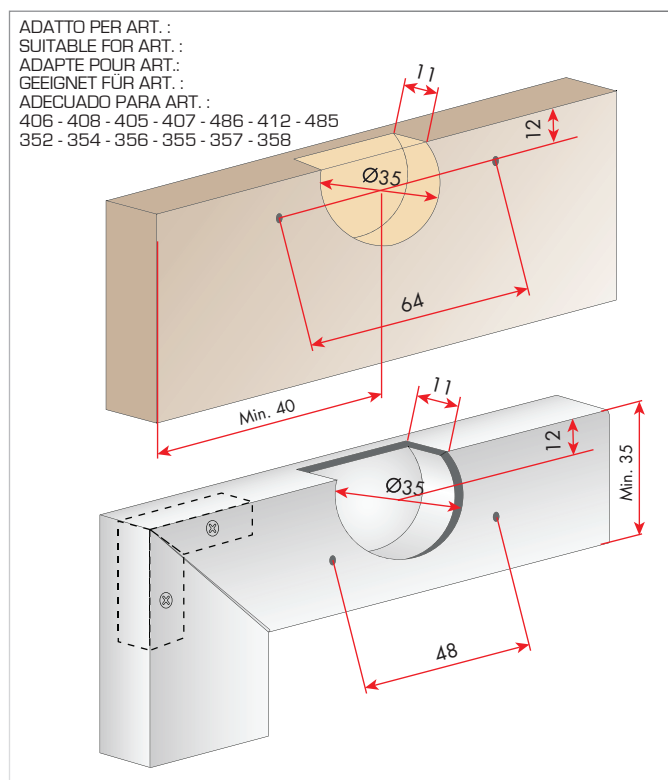
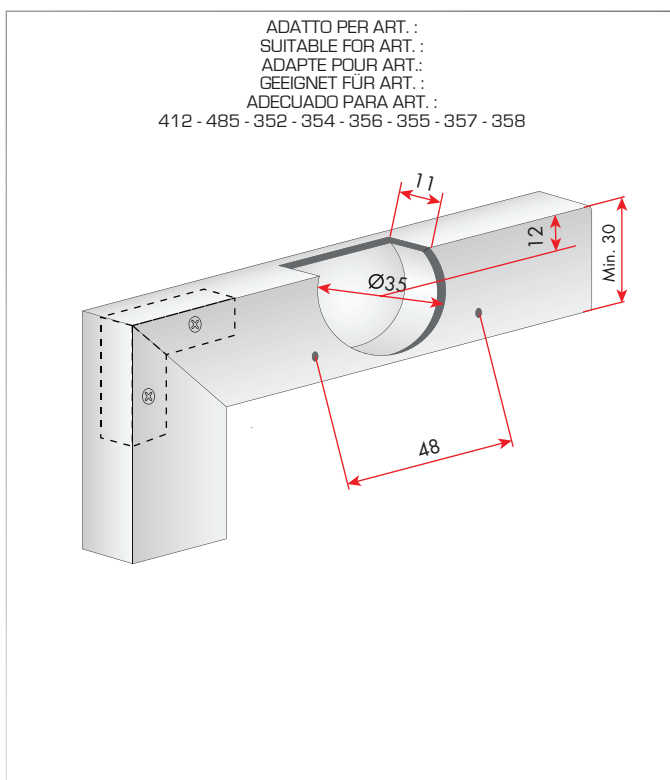
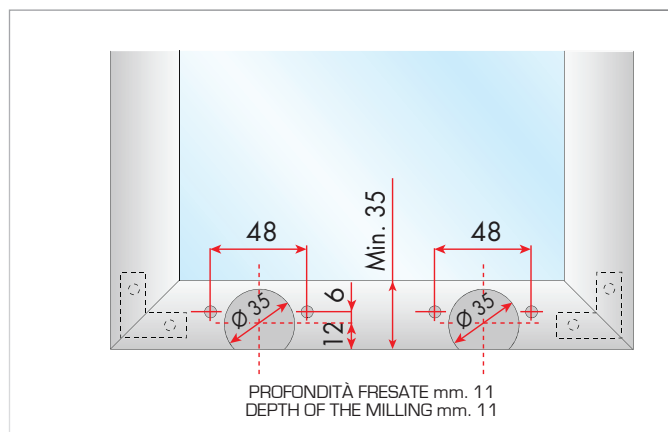
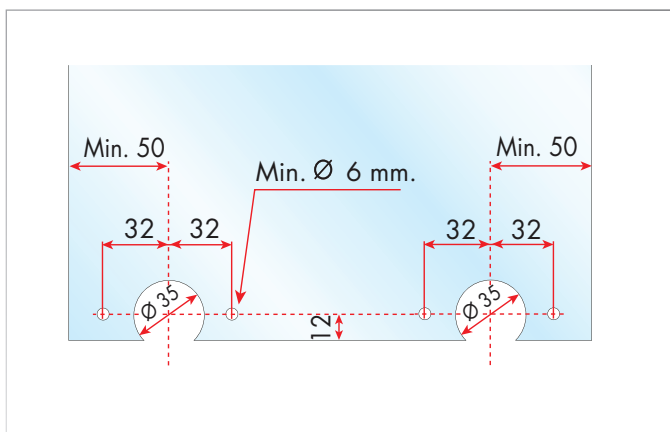
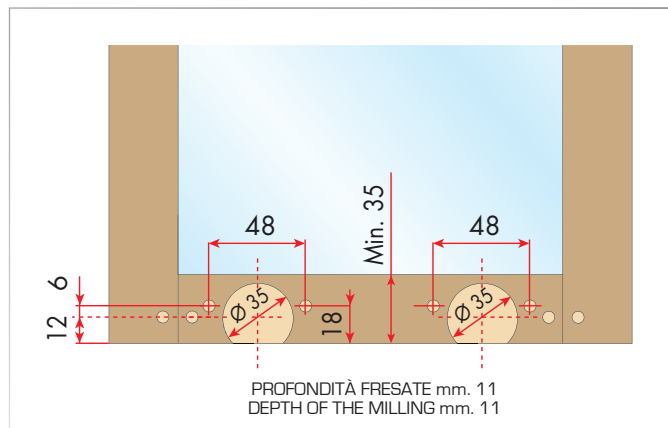
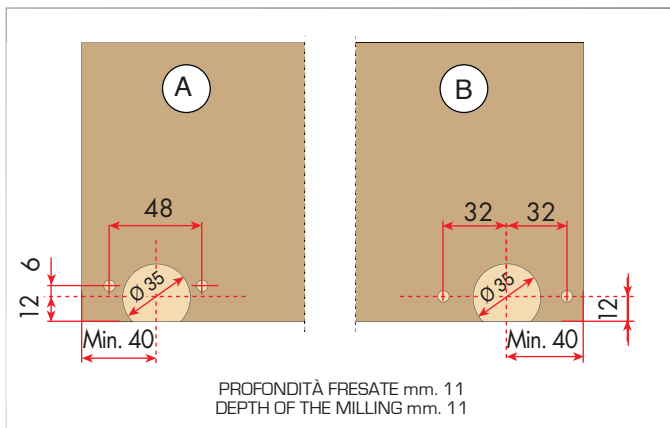

SCORRIBASE MEDIO

Kit per ante scorrevoli sovrapposte in legno



Kit for overlapping sliding wood doors
Kit pour portes coulissantes superposées en bois
Kit für übereinandergleitende schiebetüren aus Holz
Kit para puertas correderas superpuestas de madera

SCORRIBASE MEDIO

Y=18 X=14 Z=6,5
Y=20 X=16 Z=8,5
Y=22 X=18 Z=10,5

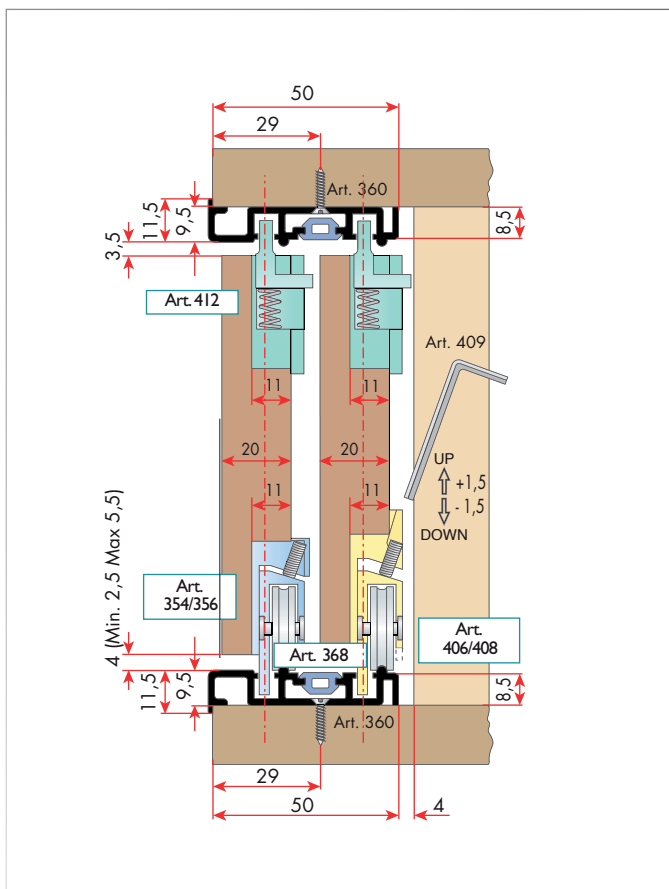
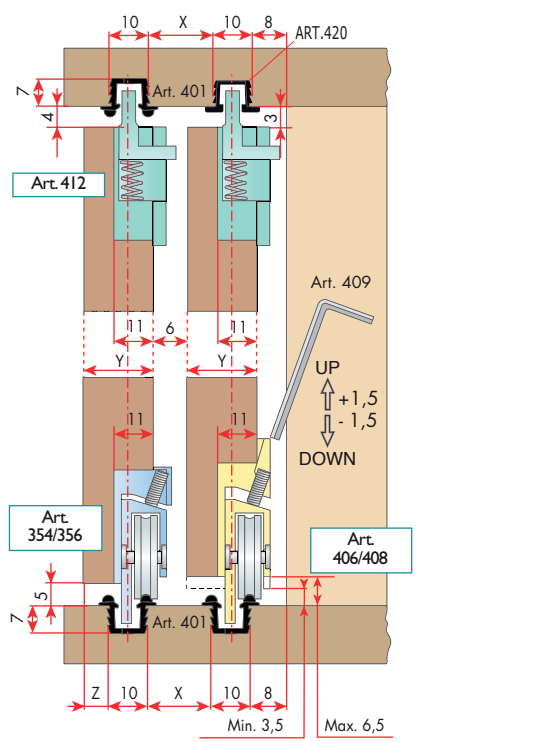

ART. 406 - 412/L KG. 30
ART. 408 - 412/L KG. 15
PER ANTA / FOR DOOR

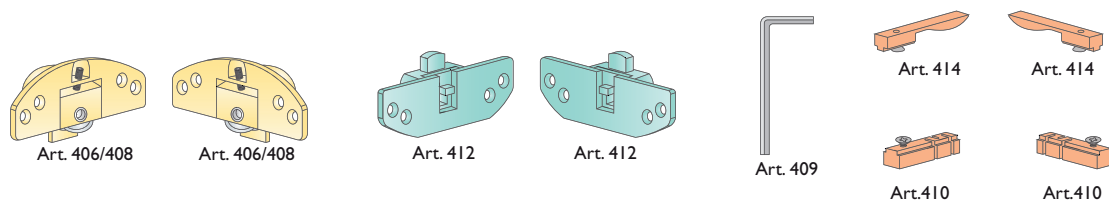

ART. 354 - 412/L KG. 40
ART. 356 - 412/L KG. 15
PER ANTA / FOR DOOR

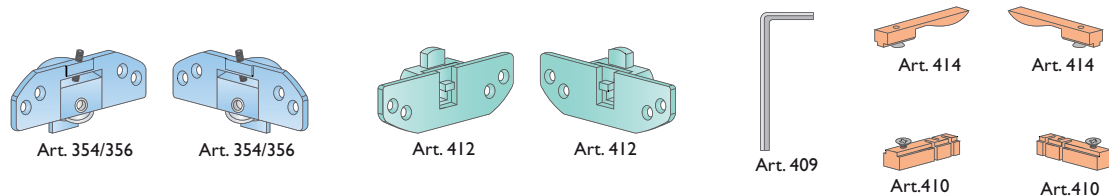

Kit per ante scorrevoli sovrapposte in vetro



Kit for overlapping sliding glass doors
Kit pour portes coulissantes superposées en verre
Kit für übereinandergleitende schiebetüren aus Glas
Kit para puertas correderas superpuestas de cristal

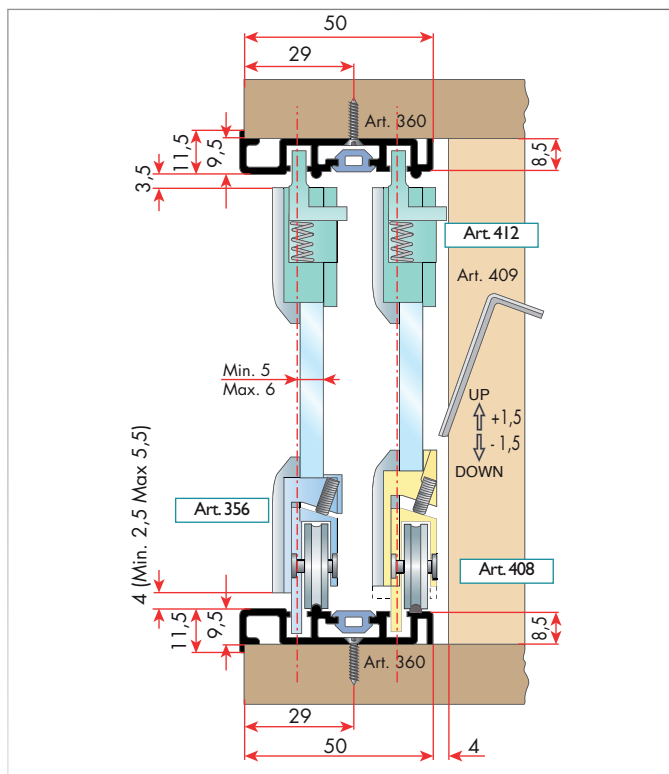
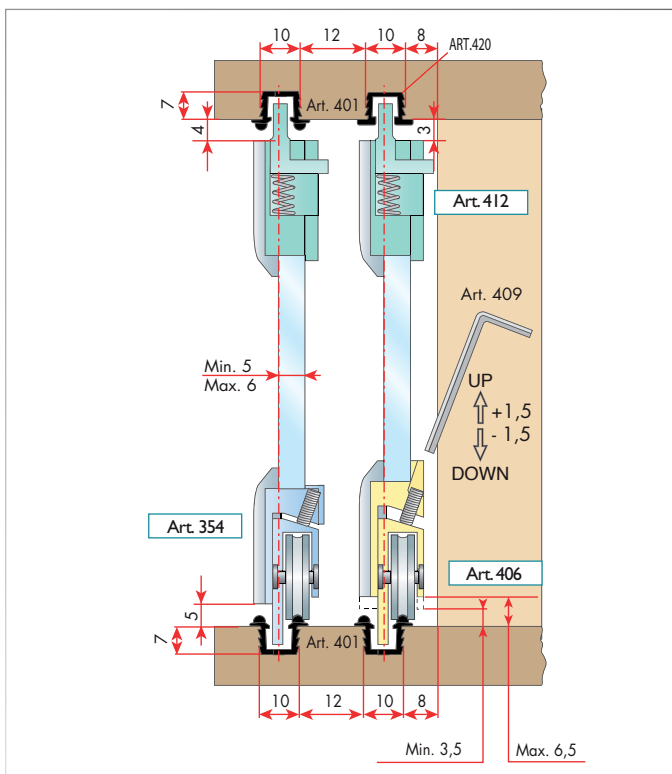

ART. 406 - 412 / 416/N ART. 406 - 412 / 418/A KG. 30 PER ANTA / FOR DOOR

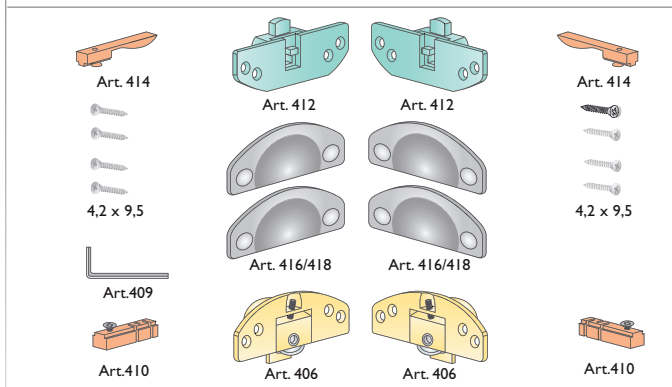

ART. 408 - 412 / 416/N ART. 408 - 412 / 418/A KG. 15 PER ANTA / FOR DOOR

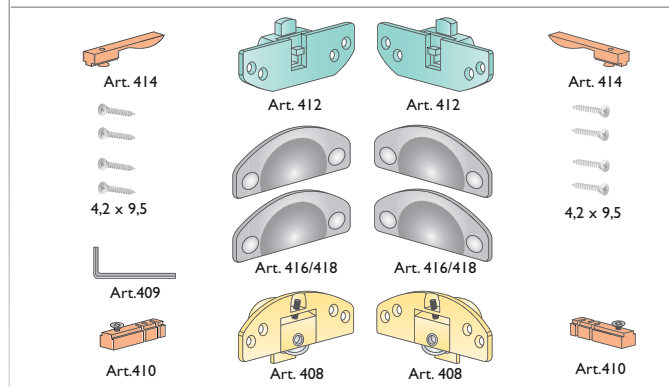

ART. 354 - 412 - 416/N ART. 354 - 412 - 418/A KG. 40 PER ANTA / FOR DOOR

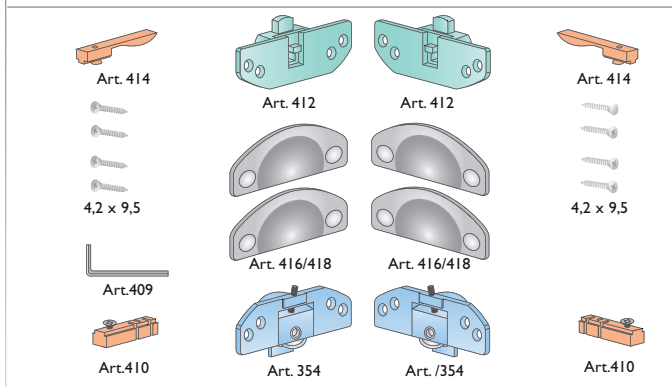

ART. 356 - 412 - 416/N ART. 356 - 412 - 418/A KG. 15 PER ANTA / FOR DOOR

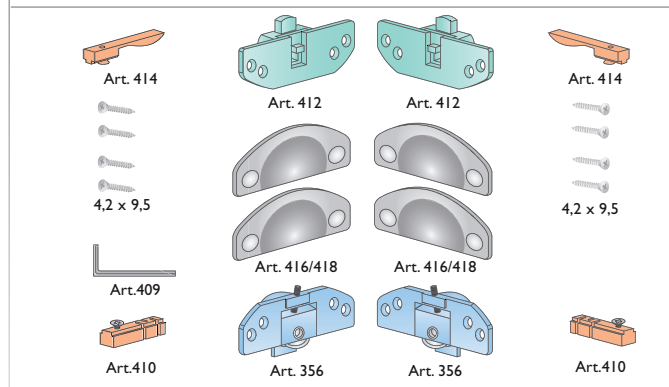

SCORRIBASE MEDIO

Misure e accessori anta art. 440 - 442 portata kg. 30

Sizes and accessories for doors articles 440 - 442 weight 30 kg
Dimensions et accessoires pour porte art. 440 - 442 portée 30 kg
Maße und zubehör für türen art 440 - 442 tragfähigkeit kg. 30
Dimensiones y accesorios para puerta art. 440 - 442 con capacidad de carga de 30 kgs.



SCORRIBASE MEDIO

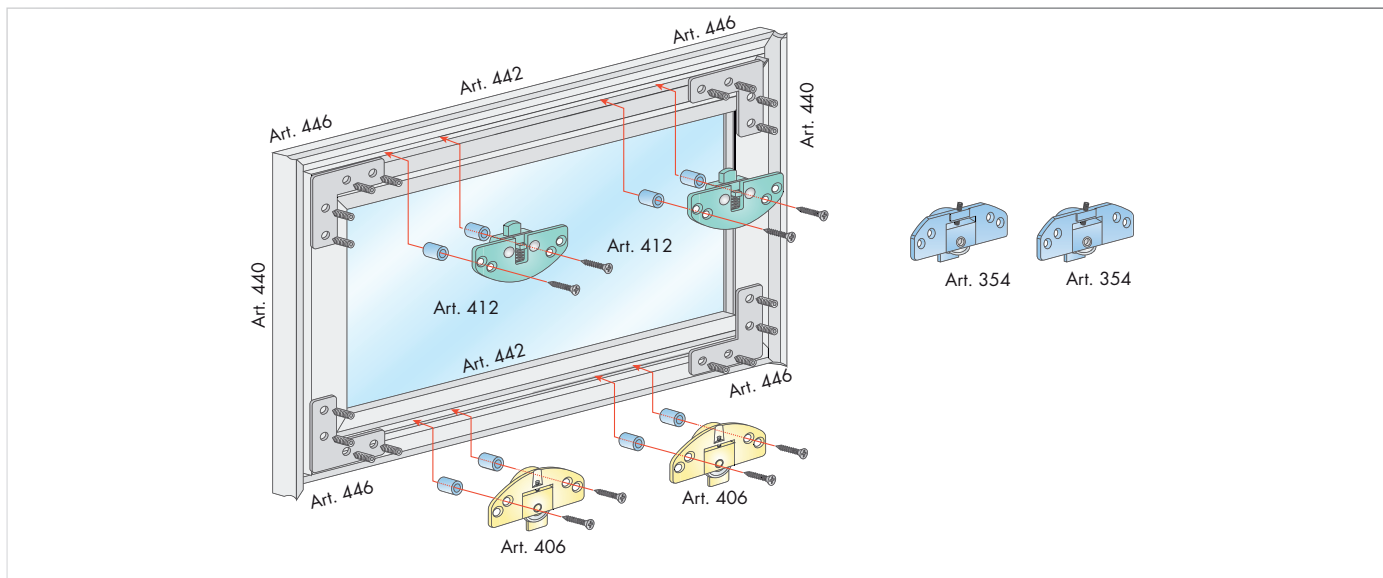
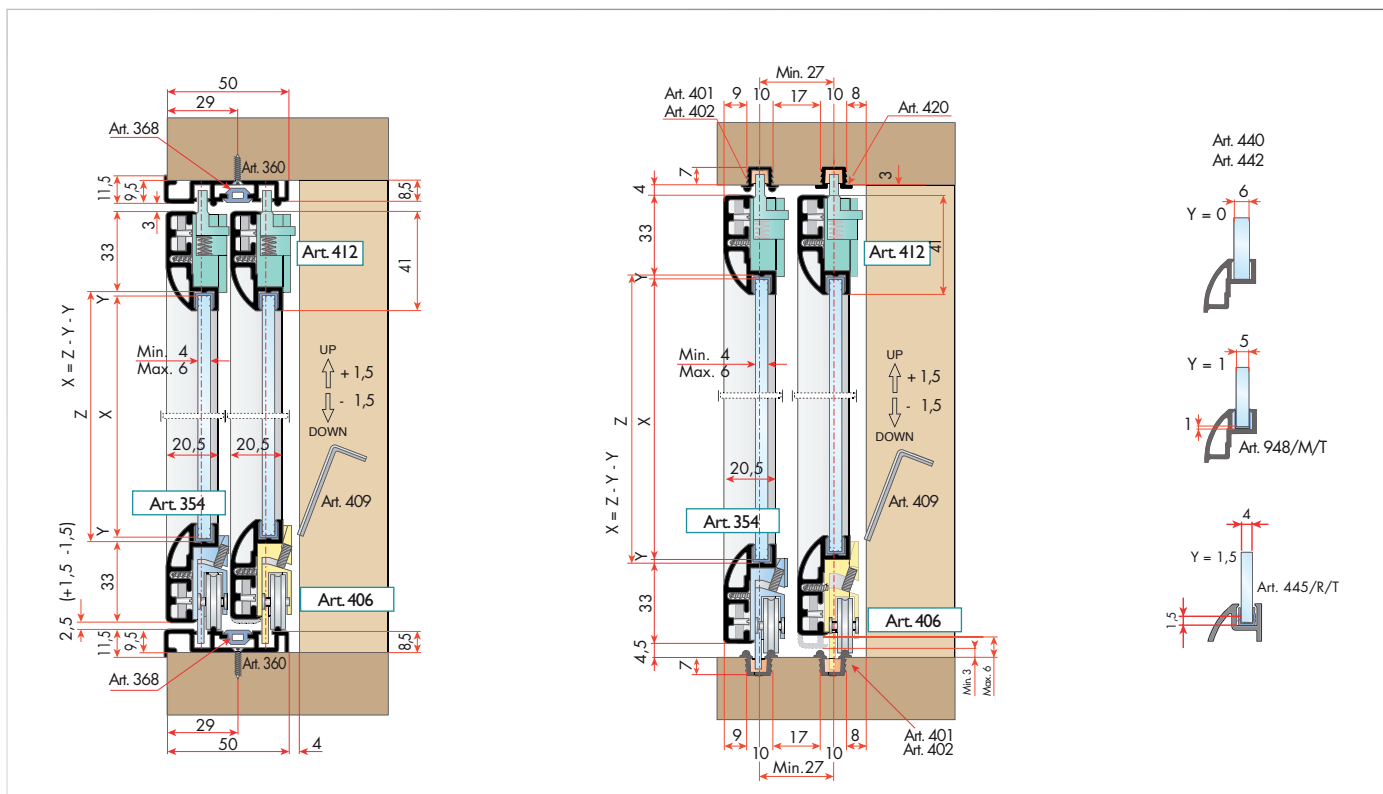

ART. 406 - 412/T KG. 30

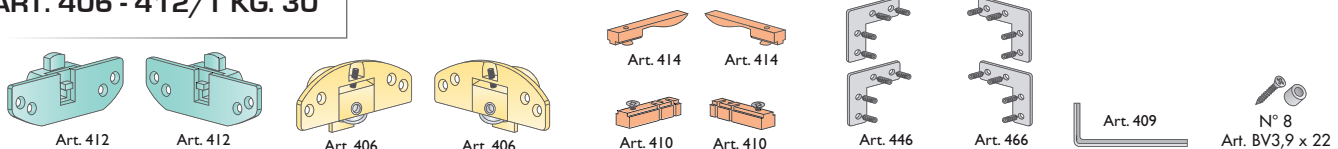

ART. 354 - 412/T KG. 30

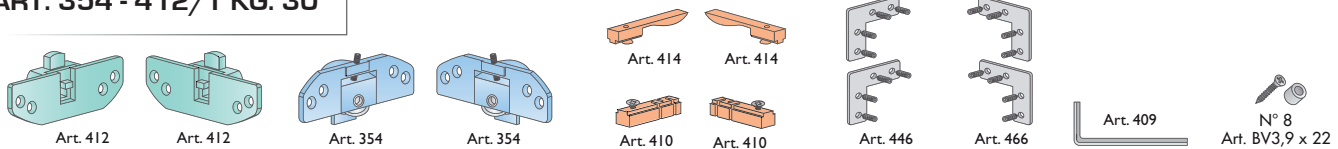

Kit per ante scorrevoli sovrapposte in legno



Kit for overlapping sliding wood doors
Kit pour portes coulissantes superposées en bois
Kit für übereinandergleitende schiebetüren aus Holz
Kit para puertas correderas superpuestas de madera

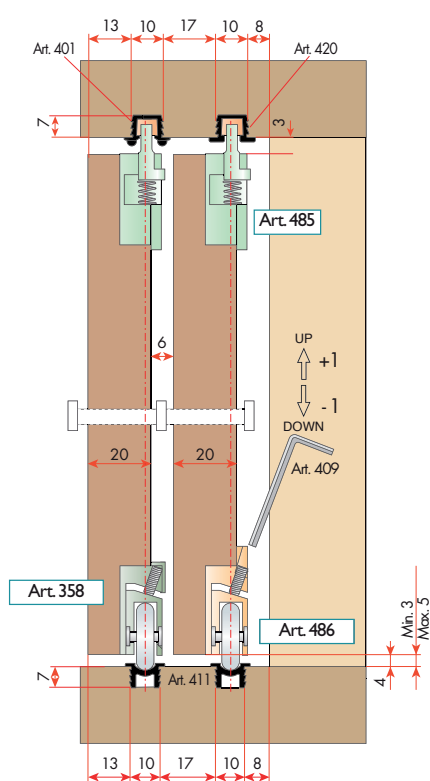
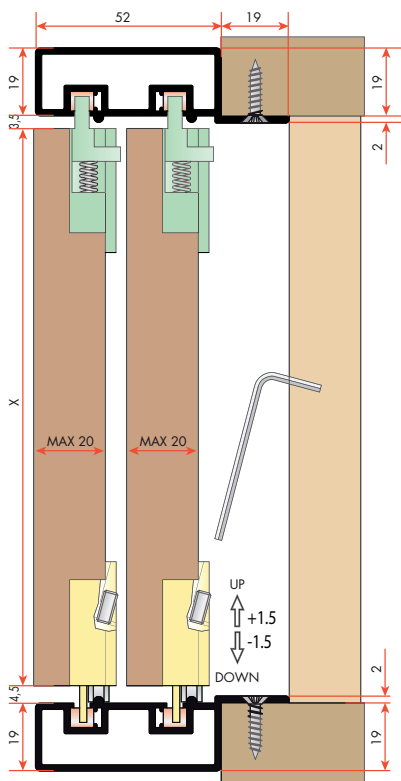
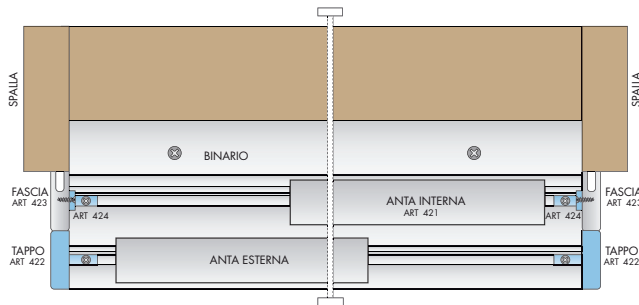
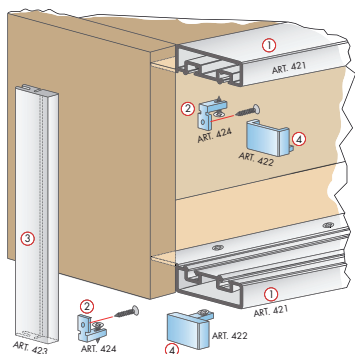

ART. 408 - 412/L/421
ART. 406 - 412/L/421
10 KG. 2 ANTE/DOORS

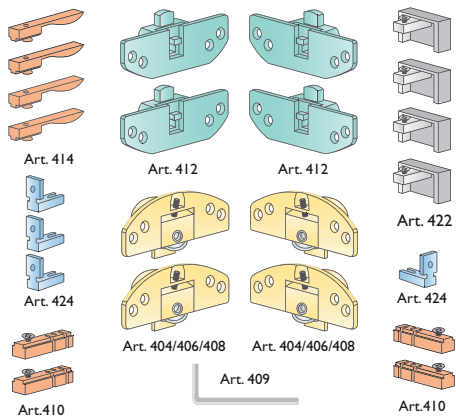

ART. 485 - 486/L
MAX KG. 40 X ANTA / X DOOR
PER ART. 411/FOR ART. 411

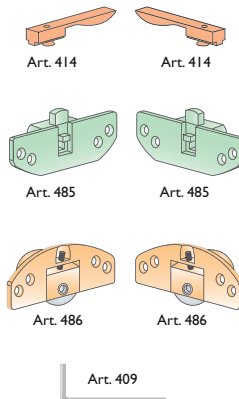

ART. 485 - 358/L
MAX KG. 40 X ANTA / X DOOR
PER ART. 411/FOR ART. 411

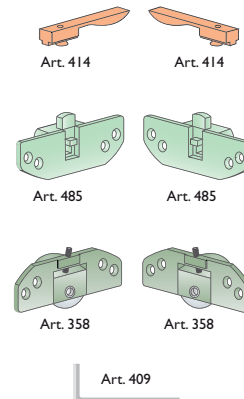

SCORRIBASE MEDIO

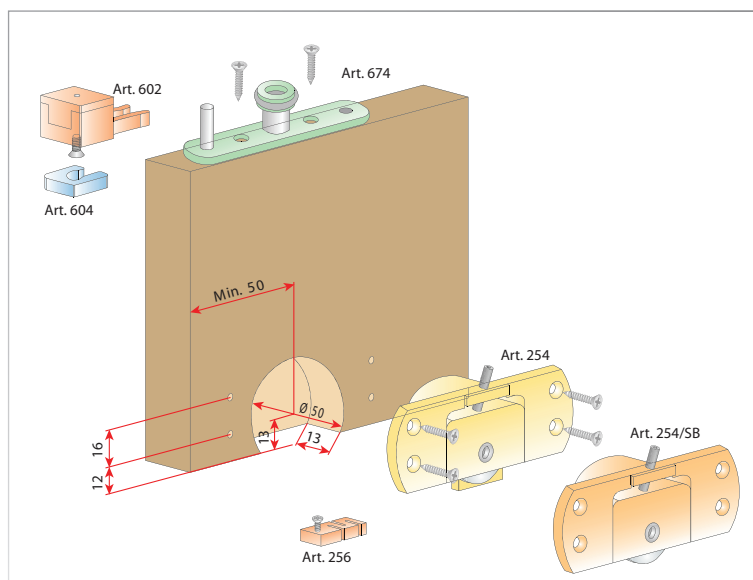
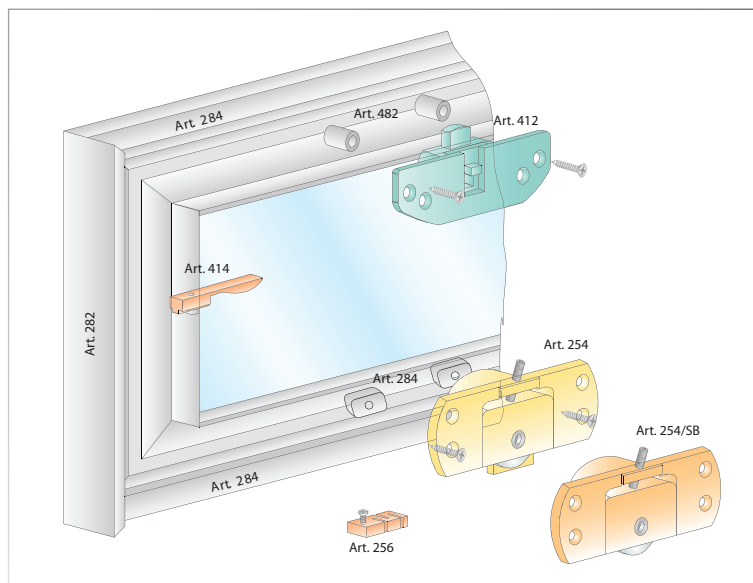
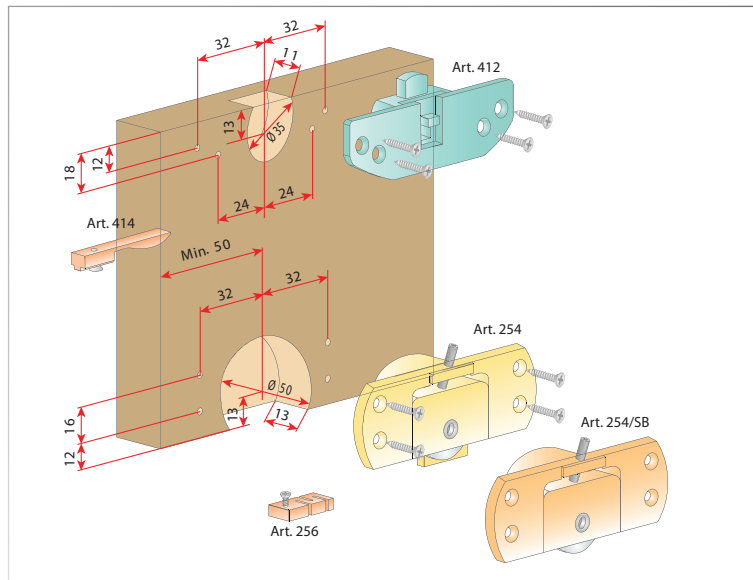

Guarnitura completa per ante scorrevoli sovrapposte



Complete gaskets for overlapping sliding doors
 Garniture complète pour portes coulissantes superposées
 Komplette garnituren für übereinandergleitende schiebetüren
 Piezas de montaje para puertas correderas superpuestas

SCORRIBASE MEDIO

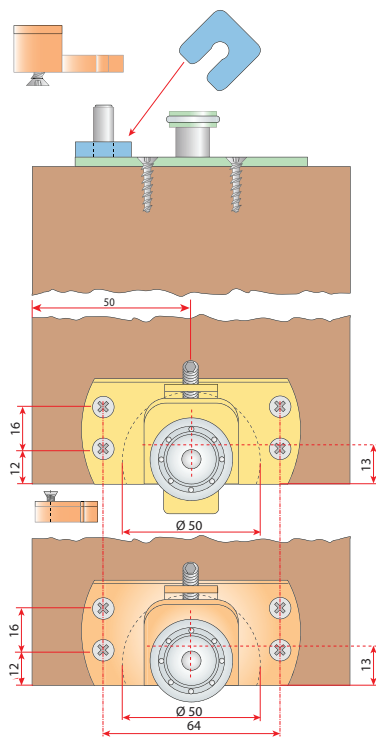

CUSCINETTO Ø 30

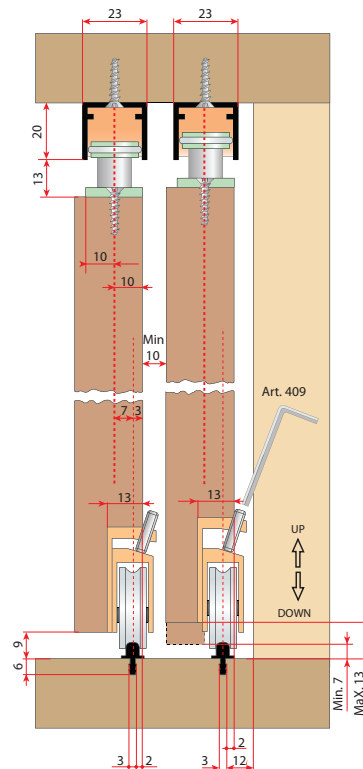
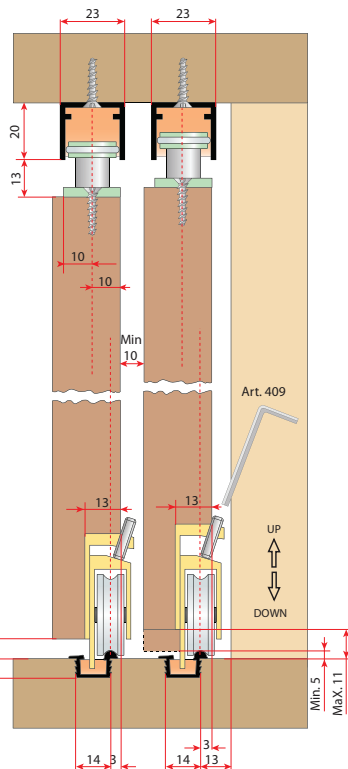

ART. 254 - 674/SB/L (SENZA VITI E BUSSOLE / WITHOUT SCREW AND BUSHES) KG.50 PER ANTA/FOR DOOR

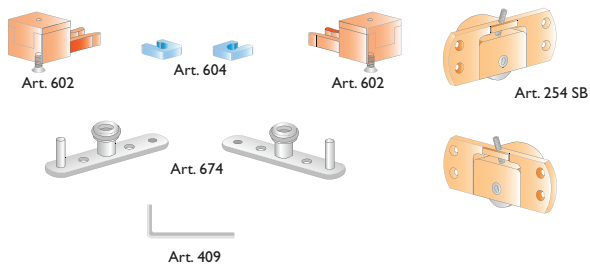

ART. 254 - 674/L (SENZA VITI E BUSSOLE / WITHOUT SCREW AND BUSHES) KG.50 PER ANTA/FOR DOOR

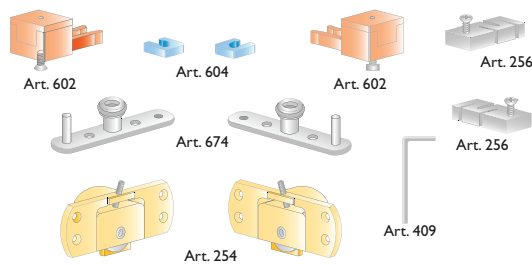

ART. 620
 Binario in alluminio
 Aluminium track
 Profilé en aluminium
 Aluminiumschiene
 Guía de aluminio



ART. 604
 Antiscacciamento
 Antiunhooking grip
 Antidetélage
 Unabhakengriff
 Elemento antidesenganche

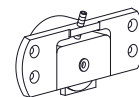

ART. 254
 Scorrevole cuscinetto rettificato
 Slide with ground bearing
 Palier de glissement rectifié
 Schlitten mit gedrehten Gleitroller
 Elemento de deslizamiento con cojinete rectificado



ART. 612
 Binario in alluminio
 Aluminium track
 Profilé en aluminium
 Aluminiumschiene
 Guía de aluminio



ART. 674
 Guida superiore
 Upper guide
 Glissière supérieure
 Obere Führung
 Guía superior



ART. 256
 Fermo inferiore
 Lower stopper
 Arrêt inférieur
 Unterer Stopper
 Tope inferior



ART. 660
 Binario in alluminio
 Aluminium track
 Profilé en aluminium
 Aluminiumschiene
 Guía de aluminio

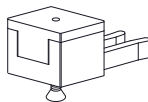

ART. 602
 Fermo superiore
 Upper stopper
 Arrêt supérieur
 Oberer Stopper
 Tope superior



ART. 409
 Chiave 2 mm.
 Key 2 mm.
 Clé 2 mm.
 Schlüssel 2 mm.
 Llave 2 mm.



ART. 280
 Binario in alluminio
 Aluminium track
 Profilé en aluminium
 Aluminiumschiene
 Guía de aluminio

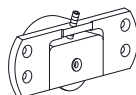

ART. 254/SB
 Scorrevole cuscinetto rettificato
 Slide with ground bearing
 Palier de glissement rectifié
 Schlitten mit gedrehten Gleitroller
 Elemento de deslizamiento con cojinete rectificado

Guarnitura completa per ante scorrevoli sovrapposte

Complete gaskets for overlapping sliding doors
 Garniture complète pour portes coulissantes superposées
 Komplette garnituren für übereinandergleitende schiebetüren
 Piezas de montaje para puertas correderas superpuestas



SCORRIBASE MEDIO

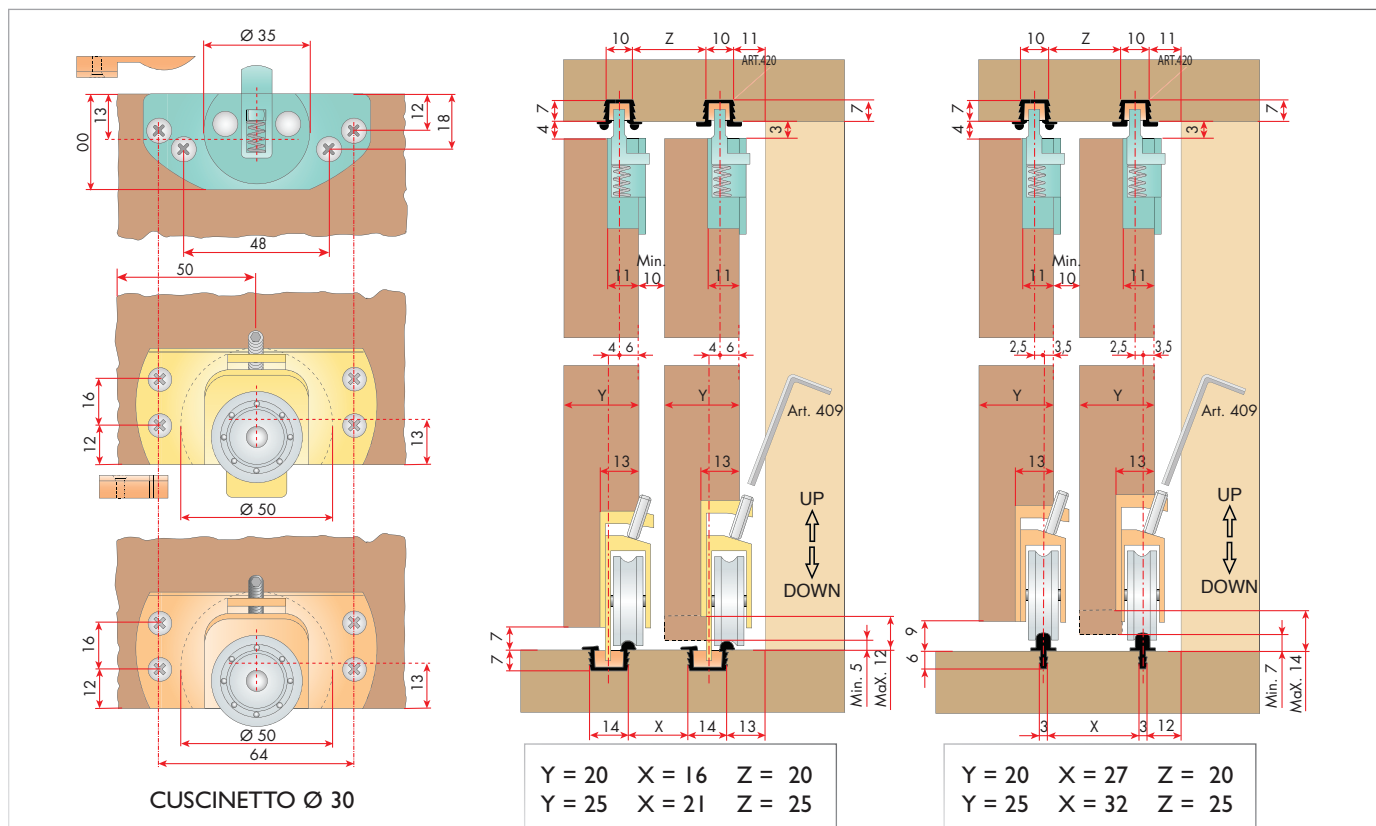

CUSCINETTO Ø 30

Y = 20 X = 16 Z = 20
 Y = 25 X = 21 Z = 25

Y = 20 X = 27 Z = 20
 Y = 25 X = 32 Z = 25

ART. 254 - 412/SB/L KG. 50 PER ANTA/FOR DOOR

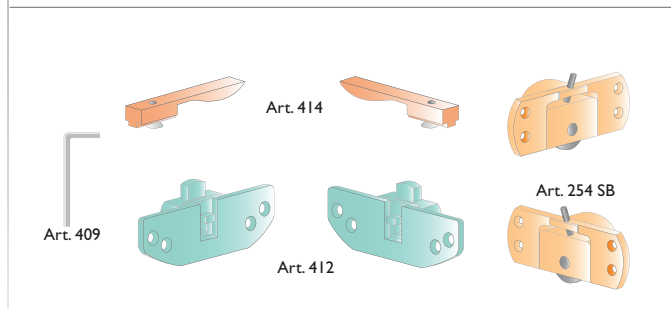

ART. 254 - 412/L

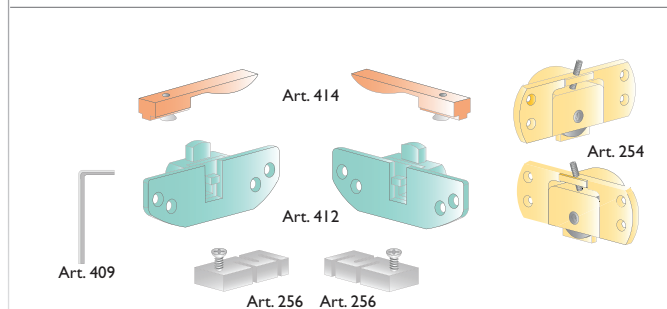

ART. 280
 Binario in alluminio
 Aluminium track
 Profilé en aluminium
 Aluminiumschiene
 Guía de aluminio

ART. 620
 Binario in alluminio
 Aluminium track
 Profilé en aluminium
 Aluminiumschiene
 Guía de aluminio

ART. 612
 Binario in alluminio
 Aluminium track
 Profilé en aluminium
 Aluminiumschiene
 Guía de aluminio

ART. 401
 Binario in alluminio
 Aluminium track
 Profilé en aluminium
 Aluminiumschiene
 Guía de aluminio

ART. 409
 Chiave 2 mm.
 Key 2 mm.
 Clé 2 mm.
 Schlusssel 2 mm.
 Llave 2 mm.

ART. 414
 Fermo superiore
 Upper stopper
 Arrêt supérieur
 Oberer Stopper
 Tope superior

ART. 412
 Guida a molla
 Spring guide
 Coulisseau à ressort
 Feder-Gleitbake
 Guía de muelle

ART. 254/SB
 Scorrevole cuscinetto rettificato
 Slide with ground bearing
 Palier de glissement rectifié
 Schlitten mit gedrehten Gleitroller
 Elemento de deslizamiento con cojinete rectificado

ART. 254
 Scorrevole cuscinetto rettificato
 Slide with ground bearing
 Palier de glissement rectifié
 Schlitten mit gedrehten Gleitroller
 Elemento de deslizamiento con cojinete rectificado

ART. 256
 Fermo inferiore
 Lower stopper
 Arrêt inférieur
 Unterer Stopper
 Tope inferior